



Description

Powered Air-Purifying Respirator

Powered Air-Purifying Respirator (PAPR)



 To help us serve you better, go to www.MillerWelds.Com/Register

OWNER'S MANUAL

File: Accessory



TABLE OF CONTENTS

SECTION 1 – SAFETY PRECAUTIONS – READ BEFORE USING	1
1-1. Symbol Usage	1
1-2. Arc Welding Hazards	1
1-3. Lens Shade Selection Table	2
1-4. Proposition 65 Warnings	3
1-5. Principal Safety Standards	3
1-6. NIOSH Approval Information	4
SECTION 2 – POWERED AIR-PURIFYING RESPIRATOR (PAPR)	5
2-1. Respirator Specifications	5
2-2. Charging The Battery	6
2-3. Installing The Battery	6
2-4. Installing The Air Filter	7
2-5. Attaching The Breathing Tube – Welding Helmet Head Assembly	8
2-6. Attaching The Breathing Tube – Hard Hat Head Assembly	9
2-7. Operating The Controls	10
2-8. Testing Air Flow	11
2-9. Testing Air Flow Alarm	12
2-10. Installing Shoulder Strap	12
2-11. Checking The Respirator Before Use	13
2-12. Putting On The Respirator	14
2-13. Maintenance And Storage	14
2-14. Respirator Troubleshooting	15
SECTION 3 – WELDING HELMET HEAD ASSEMBLY	16
3-1. Specifications	16
3-2. Helmet Configurations	17
3-3. Helmet Controls	18
3-4. Auto On/Off Button And Grind Mode / Low Battery Light	18
3-5. Mode Control Button	19
3-6. Variable Shade Control	20
3-7. Lens Delay Control	20
3-8. Sensitivity Control	21
3-9. Typical Lens Adjustment Procedure	22
3-10. Info Control Button	23
3-11. Arc Time Control	23
3-12. Clock Control	24
3-13. Timer Control	24
3-14. Alarm Control	25
3-15. Adjusting Headgear	25
3-16. Replacing Lens Covers	26
3-17. Replacing Grinding Shield On Titanium 9400i Helmet	27
3-18. Replacing The Battery	27
3-19. Installing Optional Magnifying Lens	28
3-20. Maintenance	28
3-21. Troubleshooting	29
SECTION 4 – HARD HAT HEAD ASSEMBLY	30
4-1. Specifications	30
4-2. Attaching Welding Helmet To Hard Hat	30
4-3. Adjusting Hard Hat Headgear	31
4-4. Replacing Hard Hat Lens	32
SECTION 5 – PARTS LIST	34
WARRANTY	

SECTION 1 – SAFETY PRECAUTIONS – READ BEFORE USING

PAPR 2013-04

 **Protect yourself and others from injury — read, follow, and save these important safety precautions and operating instructions.**

1-1. Symbol Usage



DANGER! – Indicates a hazardous situation which, if not avoided, will result in death or serious injury. The possible hazards are shown in the adjoining symbols or explained in the text.



Indicates a hazardous situation which, if not avoided, could result in death or serious injury. The possible hazards are shown in the adjoining symbols or explained in the text.

NOTICE – Indicates statements not related to personal injury.

 Indicates special instructions.



This group of symbols means Warning! Watch Out! ELECTRIC SHOCK, MOVING PARTS, and HOT PARTS hazards. Consult symbols and related instructions below for necessary actions to avoid the hazards.

1-2. Arc Welding Hazards



The symbols shown below are used throughout this manual to call attention to and identify possible hazards. When you see the symbol, watch out, and follow the related instructions to avoid the hazard. The safety information given below is only a summary of the more complete safety information found in the Safety Standards listed in Section 1-5. Read and follow all Safety Standards.



Only qualified persons should install, operate, maintain, and repair this unit.



During operation, keep everybody, especially children, away.



ARC RAYS can burn eyes and skin.

Arc rays from the welding process produce intense visible and invisible (ultraviolet and infrared) rays that can burn eyes and skin. Sparks fly off from the weld.

- Wear a welding helmet fitted with a proper shade of filter to protect your face and eyes when welding or watching (see ANSI Z49.1 and Z87.1 listed in Safety Standards). Refer to Lens Shade Selection table in Section 1-3.
- Wear approved safety glasses with side shields under your helmet.
- Use protective screens or barriers to protect others from flash, glare, and sparks; warn others not to watch the arc.
- Wear protective clothing made from durable, flame-resistant material (leather, heavy cotton, and wool) and foot protection.
- Before welding, adjust the auto-darkening lens sensitivity setting to meet the application.
- Stop welding immediately if the auto-darkening lens does not darken when the arc is struck. See the Owner's Manual for more information.



WELDING HELMETS do not provide unlimited eye, ear and face protection.

Arc rays from the welding process produce intense visible and invisible (ultraviolet and infrared) rays that can burn eyes and skin. Sparks fly off from the weld.

- Use impact resistant safety spectacles or goggles and ear protection at all times when using this welding helmet.
- Do not use this helmet while working with or around explosives or corrosive liquids.
- Do not weld in the overhead position while using this helmet.
- Inspect the auto-lens frequently. Immediately replace any scratched, cracked, or pitted cover lenses or auto-lenses.

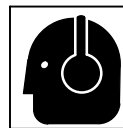

NOISE can damage hearing.

Noise from some processes or equipment can damage hearing.

- Wear approved ear protection if noise level is high.

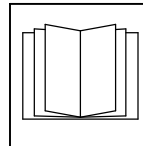

READ INSTRUCTIONS.

- Read and follow all labels and the Owner's Manual carefully before installing, operating, or servicing unit. Read the safety information at the beginning of the manual and in each section.
- Use only genuine replacement parts from the manufacturer.
- Perform maintenance and service according to the Owner's Manuals, industry standards, and national, state, and local codes.

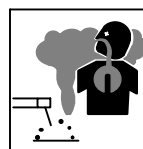

FUMES AND GASES can be hazardous.

Welding produces fumes and gases. Breathing these fumes and gases can be hazardous to your health.

- Keep your head out of the fumes. Do not breathe the fumes.
- If inside, ventilate the area and/or use local forced ventilation at the arc to remove welding fumes and gases.
- If ventilation is poor, wear an approved air-supplied respirator.
- Read and understand the Material Safety Data Sheets (MSDSs) and the manufacturer's instructions for metals, consumables, coatings, cleaners, and degreasers.
- Work in a confined space only if it is well ventilated, or while wearing an air-supplied respirator. Always have a trained watch-person nearby. Welding fumes and gases can displace air and lower the oxygen level causing injury or death. Be sure the breathing air is safe.
- Do not weld in locations near degreasing, cleaning, or spraying operations. The heat and rays of the arc can react with vapors to form highly toxic and irritating gases.
- Do not weld on coated metals, such as galvanized, lead, or cadmium plated steel, unless the coating is removed from the weld area, the area is well ventilated, and while wearing an air-supplied respirator. The coatings and any metals containing these elements can give off toxic fumes if welded.



RESPIRATOR (PAPR) MISUSE can be hazardous.

Welding produces fumes and gases. Breathing these fumes and gases can be hazardous to your health.

- Read and follow these instructions and the safety labels carefully. The powered air purifying respirator (PAPR) helps protect the user from specific airborne contaminants but must be used correctly to be fully effective. Have an industrial hygienist test the air in your facility to ensure the PAPR provides adequate protection from contaminants in your environment. If you have questions about the respirator, see equipment NIOSH label and consult your Safety Director and a certified Industrial Hygienist.
- Follow all applicable ANSI, OSHA, CSA, and other regulatory guidelines pertaining to the use of respirators.
- Do not use the powered air purifying respirator where there is danger of fire or explosion.
- Do not use the powered air purifying respirator in windy conditions or negative pressure inside the hood may draw in contaminants from the outside air.
- Do not use the powered air purifying respirator without a properly installed spark guard. Without the spark guard, welding sparks may ignite the filter or damage the filters and allow unfiltered air into the helmet.
- The powered air purifying respirator does not supply oxygen. Use the respirator only in atmospheres for which it is NIOSH approved. Do not use the respirator where oxygen levels are 19.5% or lower, where contaminant levels are unknown or are immediately dangerous to life or health (IDLH), or where the contaminant levels exceed the respirator specifications.
- Do not enter a hazardous area until you are sure the respirator equipment is correctly assembled, working properly, and properly worn.
- Before each use, inspect the respirator equipment for damage and verify it operates properly. Before using the respirator, test air flow to verify it is providing an adequate volume of air.
- Do not use the powered air purifying respirator without all filter components or with the blower turned off or hazardous levels of oxygen and carbon dioxide may accumulate in the helmet.
- Always wear the powered air purifying respirator when entering a contaminated area. Do not remove the respirator until outside the contaminated area.
- Dangerous contaminants may not smell or be visible. Leave the area immediately if you notice the following:
 - ... Breathing becomes difficult.
 - ... You experience dizziness, impaired vision, or eye, nose, or mouth irritation.
 - ... The powered air purifying respirator alarm sounds.
 - ... The equipment is damaged.
 - ... Air flow decreases or stops.
 - ... If you think the equipment is not supplying adequate protection.
 Do not remove the equipment until you are in a safe area.
- Do not repair, modify, or disassemble the powered air purifying respirator or use with parts or accessories not supplied by the manufacturer. Use only those components that are part of the NIOSH-approved assembly.
- Replace damaged or clogged filters. Do not wash or reuse filters. Do not clean filters by tapping or with compressed air or filter elements may be damaged. Dispose of used filter elements according to local, state, and federal requirements.
- The powered air purifying respirator must be used with the helmet, hood, and filters recommended by the manufacturer to provide a NIOSH-approved respirator system. See the NIOSH label for information on the required equipment.
- Do not use the powered air purifying respirator belt and shoulder straps as a safety harness.
- The powered air purifying respirator contains electrical parts which have not been evaluated as an ignition source in flammable or explosive atmospheres by MSHA/NIOSH.

1-3. Lens Shade Selection Table

Process	Electrode Size in. (mm)	Arc Current in Amperes	Minimum Protective Shade No.	Suggested Shade No. (Comfort)*
Shielded Metal Arc Welding (SMAW)	Less than 3/32 (2.4)	Less than 60	7	—
	3/32–5/32 (2.4–4.0)	60–160	8	10
	5/32–1/4 (4.0–6.4)	160–250	10	12
	More than 1/4 (6.4)	250–550	11	14
Gas Metal Arc Welding (GMAW) Flux Cored Arc Welding (FCAW)		Less than 60	7	—
		60–160	10	11
		160–250	10	12
		250–500	10	14
Gas Tungsten Arc Welding (TIG)		Less than 50	8	10
		50–150	8	12
		150–500	10	14
Air Carbon Arc Cutting (CAC-A)	Light Heavy	Less than 500	10	12
		500–1000	11	14
Plasma Arc Cutting (PAC)		Less than 20	4	4
		20–40	5	5
		40–60	6	6
		60–80	8	8
		80–300	8	9
		300–400	9	12
Plasma Arc Welding (PAW)		Less than 20	6	6–8
		20–100	8	10
		100–400	10	12
		400–800	11	14

Reference: ANSI Z49.1:2005

* Start with a shade that is too dark to see the weld zone. Then, go to a lighter shade which gives a sufficient view of the weld zone without going below the minimum.

1-4. Proposition 65 Warnings

 Welding or cutting equipment produces fumes or gases which contain chemicals known to the State of California to cause birth defects and, in some cases, cancer. (California Health & Safety Code Section 25249.5 et seq.)

 This product contains chemicals, including lead, known to the state of California to cause cancer, birth defects, or other reproductive harm. *Wash hands after use.*

1-5. Principal Safety Standards

Safety in Welding, Cutting, and Allied Processes, ANSI Standard Z49.1, is available as a free download from the American Welding Society at <http://www.aws.org> or purchased from Global Engineering Documents (phone: 1-877-413-5184, website: www.global.ihs.com).

Safe Practice For Occupational And Educational Eye And Face Protection, ANSI Standard Z87.1, from American National Standards Institute, 25 West 43rd Street, New York, NY 10036 (phone: 212-642-4900, website: www.ansi.org).

SECTION 2 – POWERED AIR-PURIFYING RESPIRATOR (PAPR)

⚠ This equipment helps protect the user from certain contaminants. All users must read and understand these instructions and be trained in the proper use of this equipment before using. Use this equipment according to all applicable health and safety standards. If you have questions about the type of respiratory equipment required, consult your safety director and an Industrial Hygienist.

⚠ Do not enter a hazardous area until you are sure the respirator equipment is correctly assembled, working properly, and properly worn.

☞ See Section 3 for information on the auto-darkening helmet assembly. See Section 4 for information on the hard hat option.

The powered air-purifying respirator (PAPR) filters contaminated air and blows it into the welding helmet hood through a flexible breathing tube. The respirator system generates a positive air pressure to help prevent contaminants from entering the hood. The system must include and/or be used with the equipment listed below:

- Helmet or helmet/hardhat option with auto-darkening lens, hood, and headgear system
- Breathing Tube
- Blower assembly with filtration system (spark guard, foam prefilter, HEPA filter), and low battery and low air flow alarms
- Belt assembly
- Air flow indicator
- Battery charger

The respirator equipment operates at temperatures from 23° to 131° F and provides air flow of 6+ CFM (low speed) to 7.06 CFM (high speed) under normal conditions. Battery life is reduced when the unit is used in a dirty environment. If the system air flow decreases to an unsafe level, an alarm will sound, the blower vibrates, and the Danger light will flash to warn the user to immediately leave the contaminated area. Use the supplied air flow indicator to determine if the unit is supplying adequate amounts of clean air.

2-1. Respirator Specifications

Size (Blower Assembly)	9-1/2 x 8-1/4 x 3 in. (241 x 210 x 76 mm)
Weight (Blower Assembly, Filters, Belt, Shoulder Straps, and Battery)	51.7 oz. (1466 g)
Standard Air Filter	Filter Assembly Consisting Of A Spark Guard Screen, Foam Prefilter, And Particulate (HEPA) Filter – All Part Of The NIOSH-Approved PAPR. Approved To Filter Particulate Down To 0.3 Micrometers In Size.
Air Flow	Low Speed: 6+ CFM (170+ LPM) minimum High Speed: 7.06 CFM (200 LPM)
Operating Temperature	23° to 131° F (–5° to 55° C)
Storage Temperature	14° to 176° F (–10° to 80° C)
Battery Type	Rechargeable Lithium
Battery Charging Time	About Three hours
Battery Life	500 Charges – Run Time Dependent On Air Flow Rate And Filter Load.
Belt size	28 to 55 in. (711 to 1397 mm)

Notes

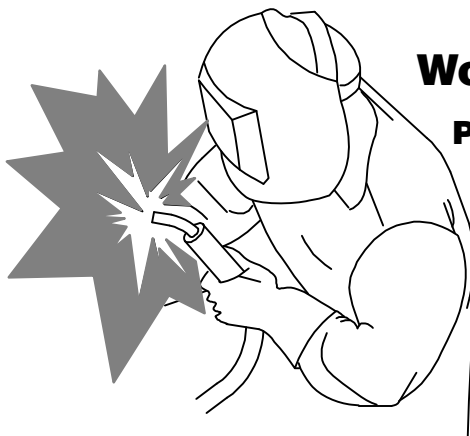

Work like a Pro!
Pros weld and cut safely. Read the safety rules at the beginning of this manual.

2-2. Charging The Battery

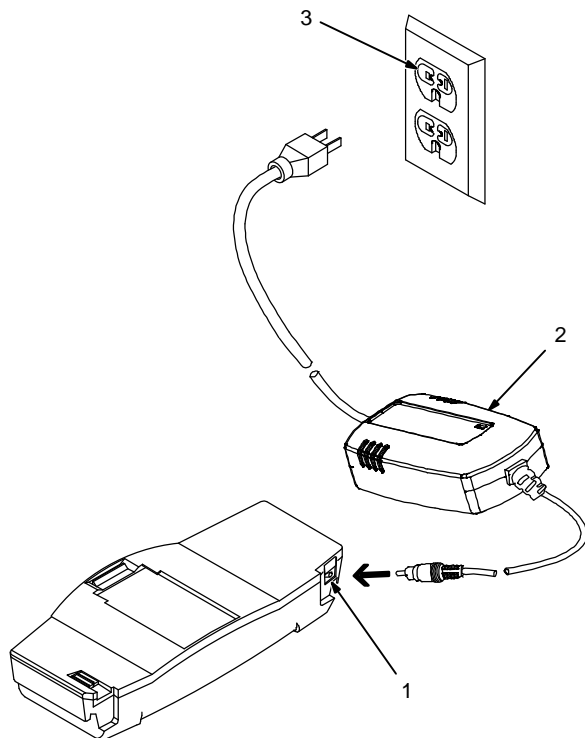
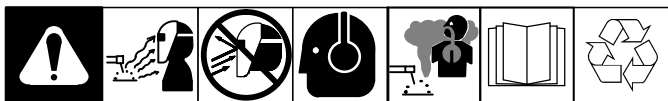

- Charge battery only with supplied charger in an open, well-ventilated location.
- Do not allow battery to get wet. Do not attempt to open the battery case.
- Keep battery away from fire or heat.
- Charge battery before first use or if battery has not been used for five days.

Dispose of battery at a designated collection facility.

Battery charging stops when battery is fully charged.

- 1 Battery Terminal
- 2 120 Volt AC Battery Charger
- 3 120 Volt AC Receptacle

Remove battery from blower assembly. Connect charger cord to battery terminal. Connect charger to 120 volt AC receptacle.

The charger red light goes on when battery is being charged. When fully charged, the charger green light goes on. Charging normally takes about four hours.

If red light flashes during charging, stop charging for 30 minutes then charge battery an additional 20 minutes (green light will be on).

805 099

2-3. Installing The Battery

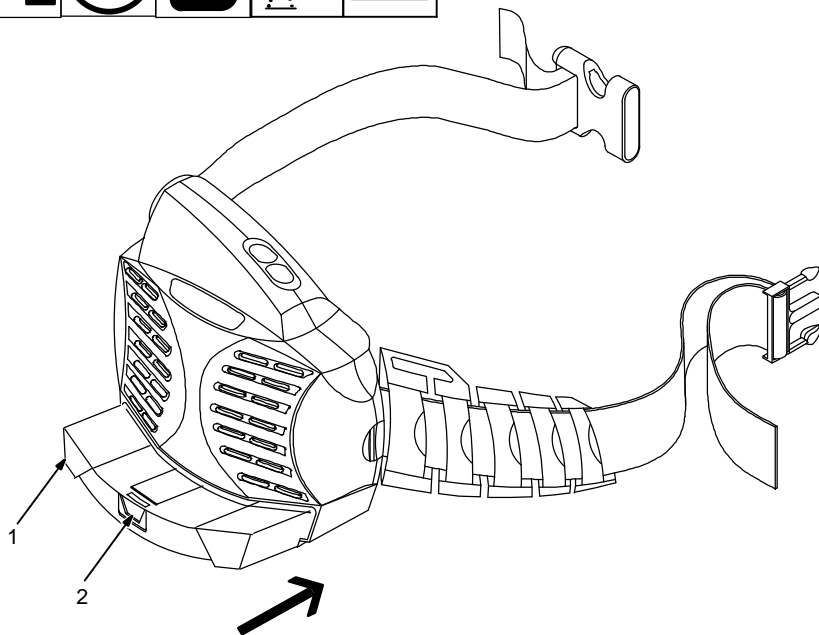
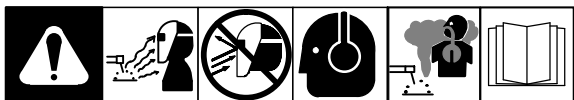

- 1 Battery
- 2 Battery Unlock Button

Slide battery into blower body until battery snaps into position.

To remove battery, push battery unlock button down and pull battery from blower assembly.

Ref. 805 068

2-4. Installing The Air Filter

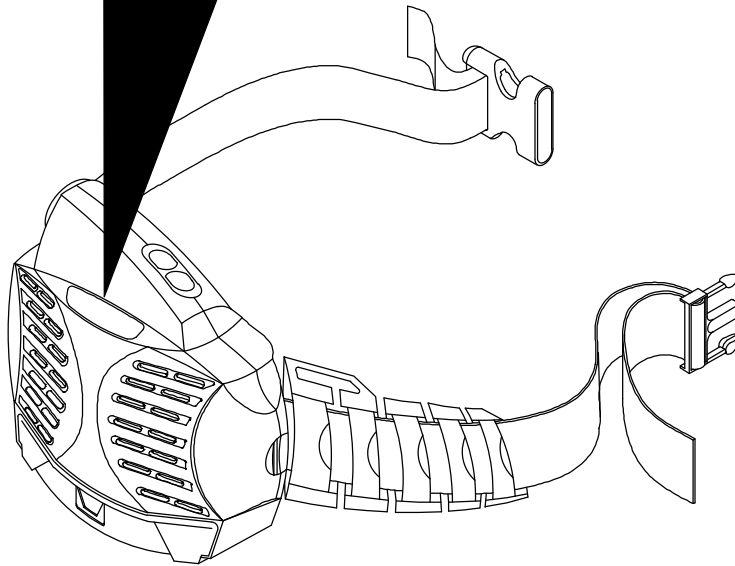
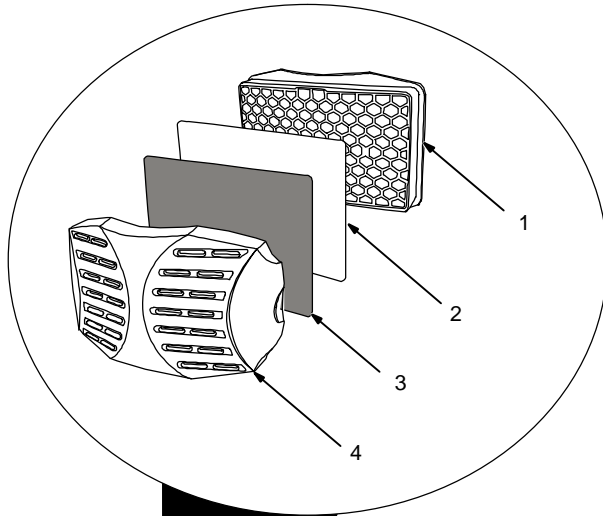
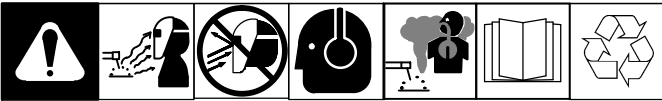

⚠ Do not use the respirator without the spark guard screen, foam prefilter, and particulate (HEPA) filter installed.

⚠ Replace damaged or dirty air filters. Do not wash filters, clean with compressed air, or reuse dirty air filters.

 *Dispose of used filters at a designated collection facility.*

- 1 Particulate (HEPA) Filter
- 2 Foam Prefilter
- 3 Spark Guard Screen
- 4 Cover

Install the screen, prefilter, and particulate filter in cover exactly as shown.

Install the filter assembly by sliding the tabs on the cover into the bracket on the blower body; push down on the filter until it "clicks" into position.

2-5. Attaching The Breathing Tube – Welding Helmet Head Assembly

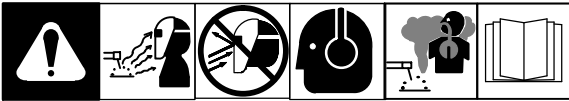

⚠ Be sure breathing tube is properly installed or contaminated air may enter the helmet.

Connecting Breathing Tube To Helmets Equipped With Tab Connector

- 1 Locking Tab

Push breathing tube connector (rectangular end) into helmet air inlet until breathing tube locks in position. (Locking tab should be on outside of helmet air inlet.)

⚠ Do not insert breathing tube locking tab into helmet inlet. Locking tab should be on outside of helmet air inlet.

Connecting Breathing Tube To Blower

Align pins on breathing tube connector (blower end) with channels in blower receptacle. Insert tube connector into blower receptacle until snug and then turn connector 1/8 turn clockwise.

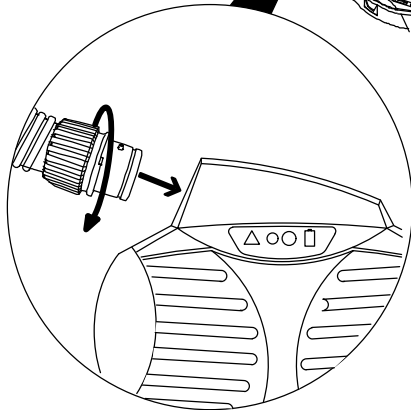
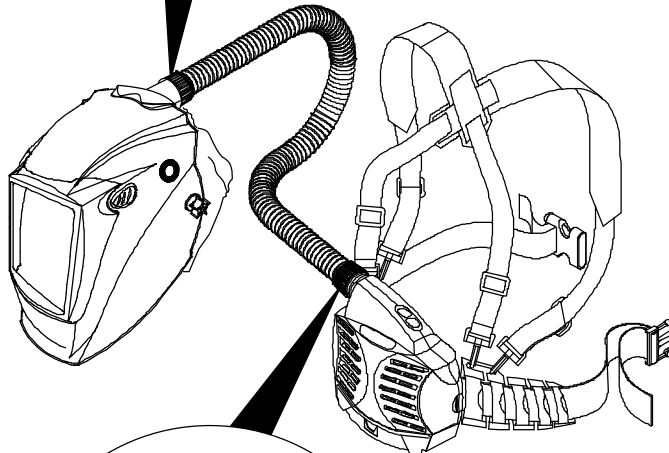
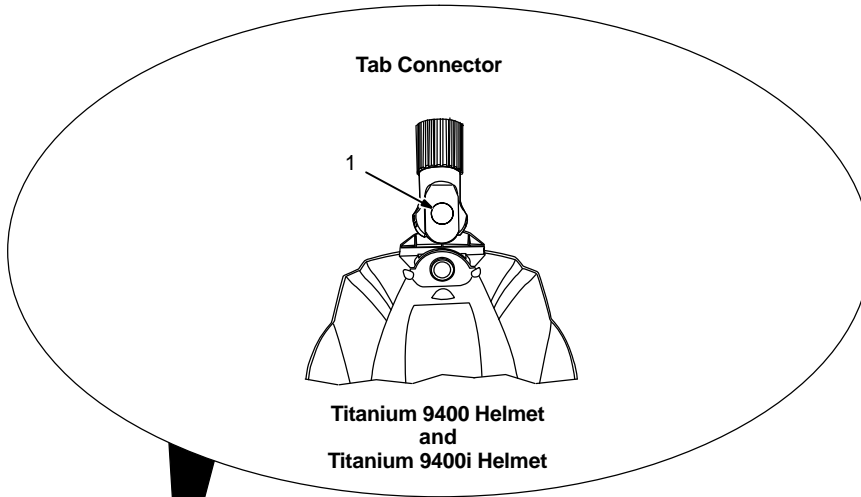

2-6. Attaching The Breathing Tube – Hard Hat Head Assembly

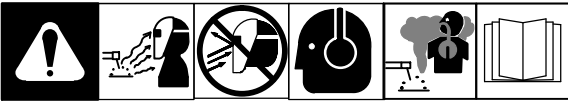

⚠ Be sure breathing tube is properly installed or contaminated air may enter the hard hat.

Connecting Breathing Tube To Hard Hat

1 Locking Tabs

Align breathing tube connector locking tabs with channels in hard hat air inlet. Push breathing tube connector into helmet air inlet. Rotate breathing tube clockwise until breathing tube locks in position.

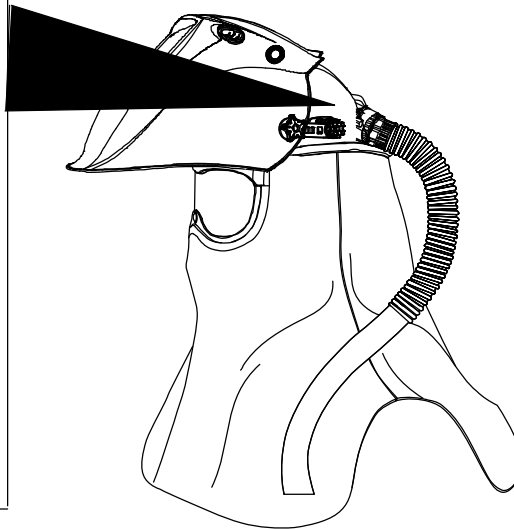
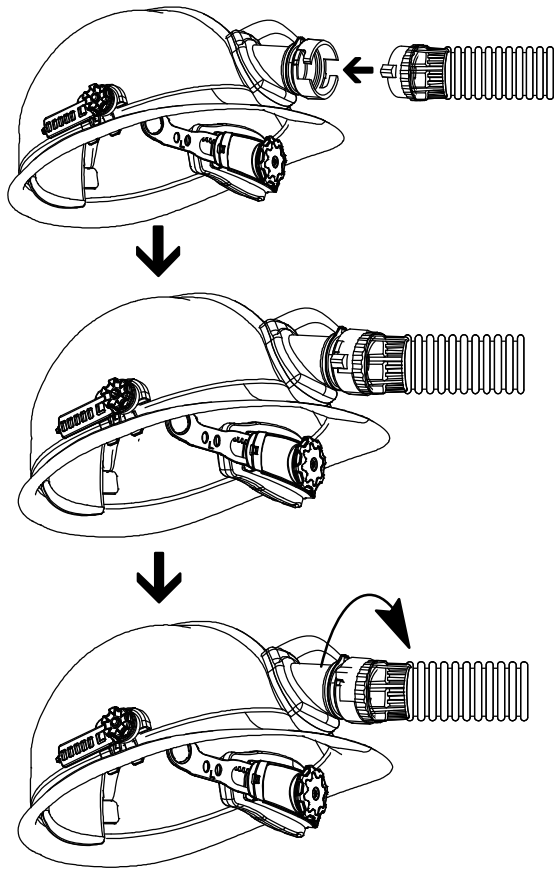

Connecting Breathing Tube To Blower

Align pins on breathing tube connector (blower end) with channels in blower receptacle. Insert breathing tube connector into blower receptacle until snug and then turn connector 1/8 turn clockwise.

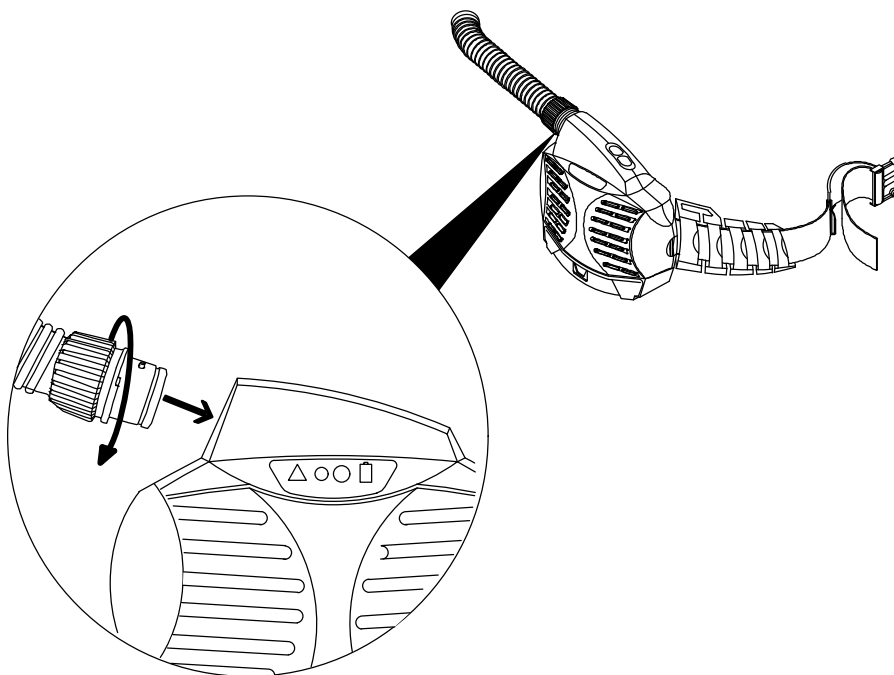

2-7. Operating The Controls

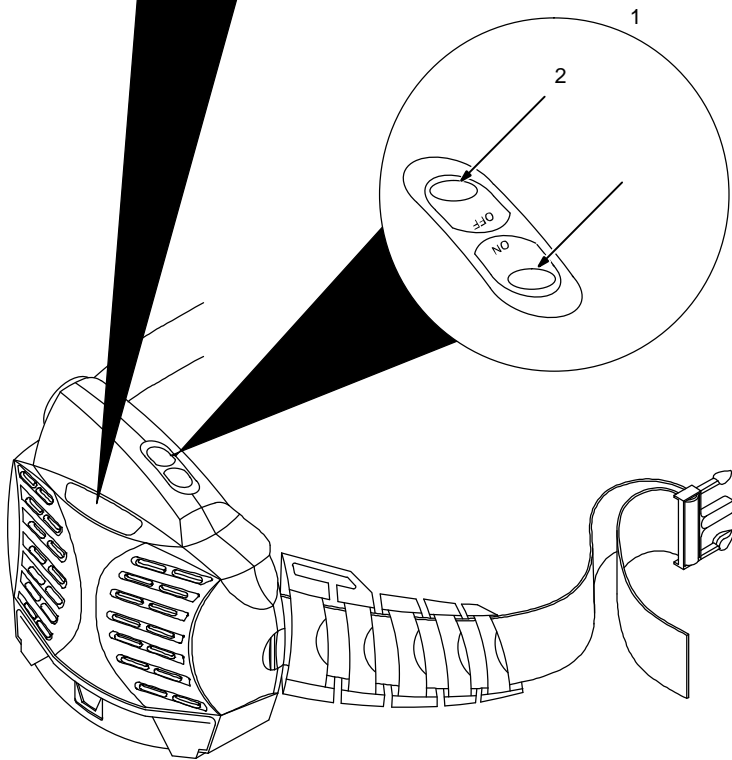
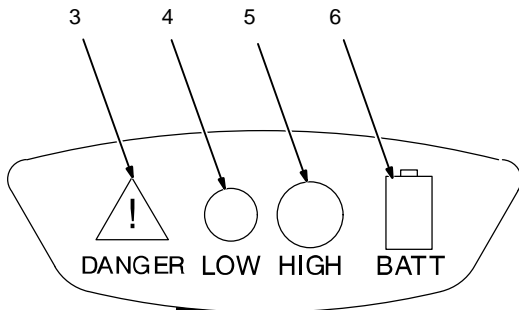
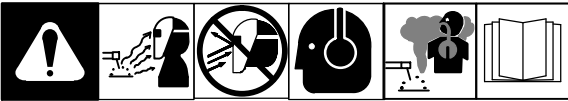

⚠ Leave the contaminated area immediately if the Danger light goes On, the alarm sounds, or the blower vibrates. Do not remove the equipment until you are in a safe area.

- 1 On Button
- 2 Off Button
- 3 Danger Indicator
- 4 Low Speed Indicator
- 5 High Speed Indicator
- 6 Battery Level Indicator

☞ Indicator lights are always red.

To Start: Press On button for 1–2 seconds until the blower starts. The Danger indicator lights and then goes out, the alarm sounds, and the blower vibrates momentarily.

The blower always starts at the low speed. Press the On button to switch between High and Low speeds.

To Stop: Press Off button for 2 – 3 seconds until the audible alarm and blower stop.

The Danger indicator light goes on, the alarm sounds, and the blower vibrates if battery power is low or air flow is reduced due to a dirty filter, blocked breathing tube, or other problem. See Section 2-14, Troubleshooting.

The Battery Level indicator lights show the power remaining in the battery. When all three lights are on the battery is fully charged.

2-8. Testing Air Flow

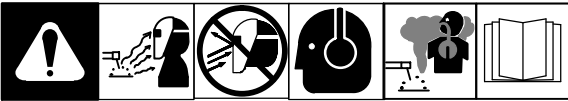

Always test air flow before using the respirator. Also check air flow each month if respirator is not used regularly.

- 1 Flowmeter
- 2 Breathing Tube Connector (Hood)

Disconnect breathing tube from hood. Insert flowmeter into breathing tube. Be sure breathing tube is straight and untwisted. Hold flowmeter straight up and start blower.

Air flow is adequate if flowmeter ball moves above MIN mark. Do not use respirator if flowmeter reads MIN or below. If air flow is low, check battery and filter elements and recheck air flow.

Hard Hat Head Assemblies

Titanium 9400 Helmet
Titanium 9400i Helmet
Head Assemblies

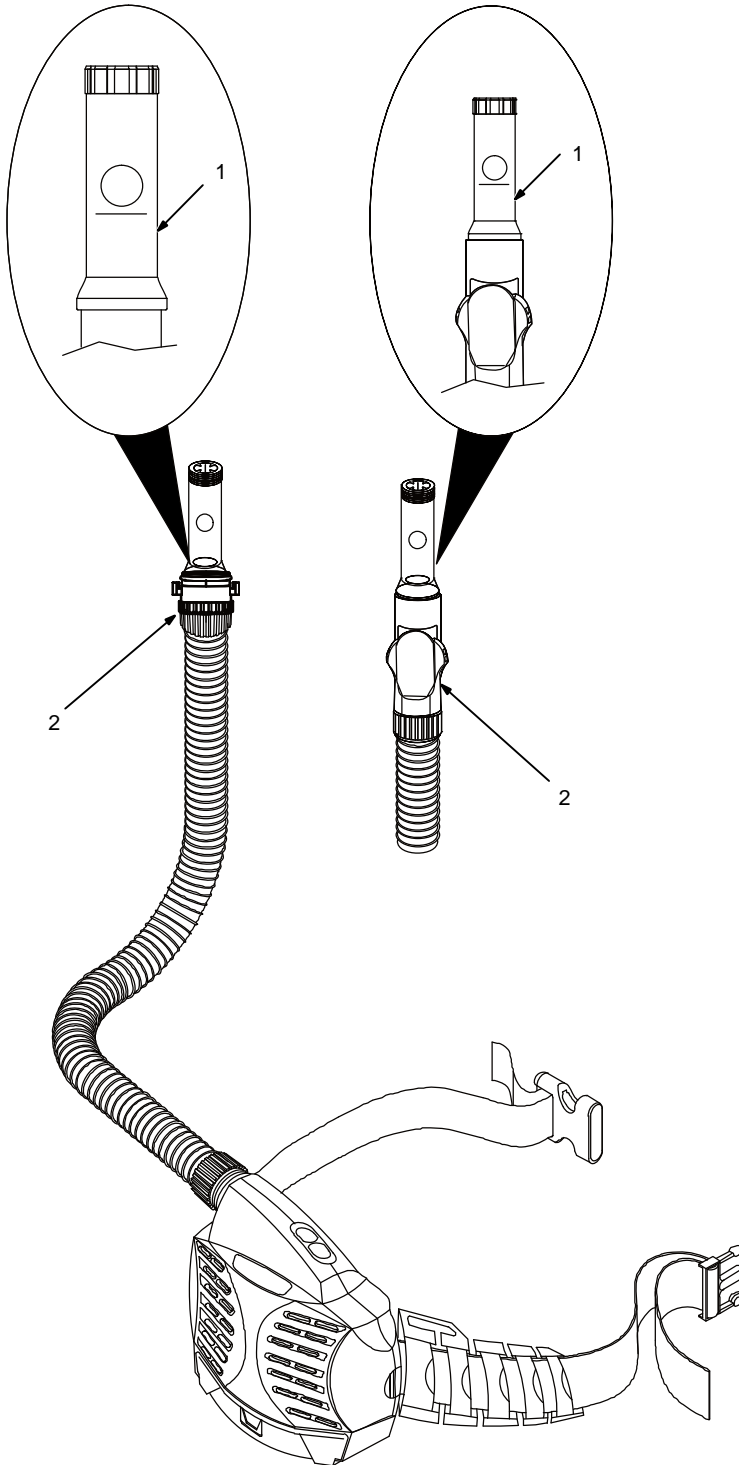

2-9. Testing Air Flow Alarm

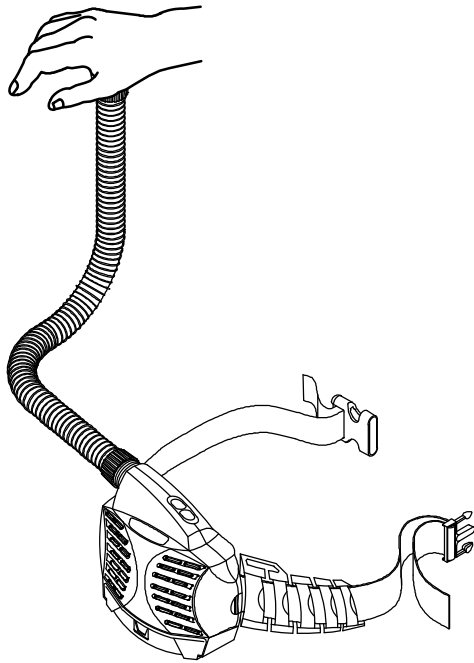
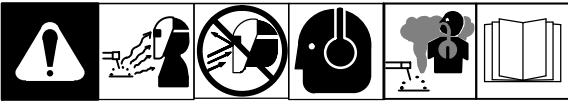

⚠ Always test air flow alarm before using the respirator. Also check air flow alarm each month if respirator is not used regularly.

Disconnect breathing tube from hood. Start blower and block air flow by placing your hand over the end of the breathing tube. Continue blocking air flow until alarm sounds and the blower vibrates (about 15 to 20 seconds).

If alarm does not sound and the blower does not vibrate, check battery and filter element.

805 101

2-10. Installing Shoulder Strap

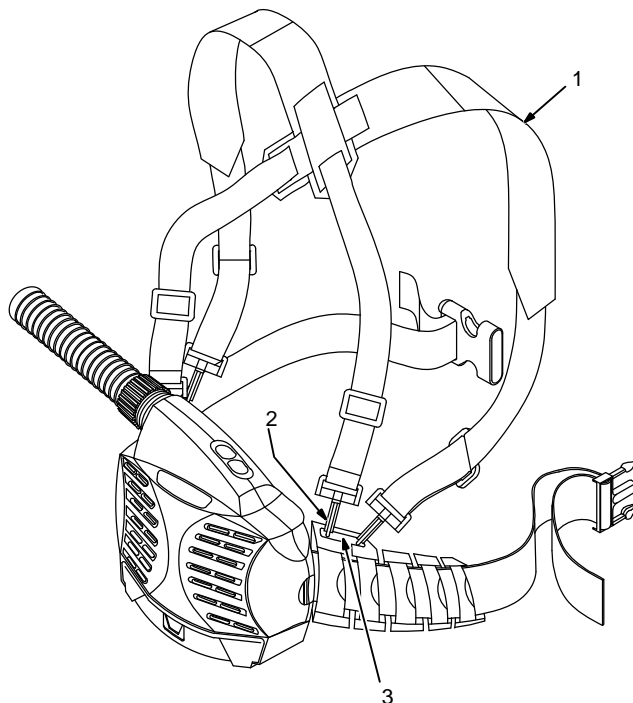
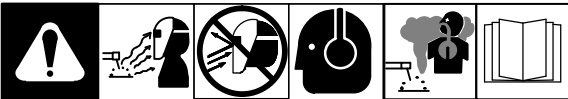

- 1 Shoulder Strap
- 2 Snap
- 3 Link

Connect snaps on shoulder straps to links on belt.

805 068

2-11. Checking The Respirator Before Use

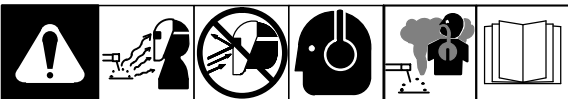

Before using the respirator, check the following items:

1 Air Filter Assembly

Verify the air filter is suitable for the application and is NIOSH-approved. Also be sure the filter is undamaged, properly assembled, and securely connected to the blower assembly.

2 Breathing Tube

Be sure the tube is undamaged and properly connected to the blower assembly and hood.

3 Battery

Verify the battery is fully charged and securely connected to the blower assembly.

4 Air Flow (Not Shown)

Test air flow according to Section 2-8.

5 Air flow Alarm

Turn on blower assembly and check for audible, visual, and vibratory alarms (see Sections 2-7 and 2-9). See Troubleshooting section if alarms go on at any other time (Section 2-14).

6 Hood

Inspect the hood and replace if damaged. See Troubleshooting (Section 2-14) if air is not being supplied to hood.

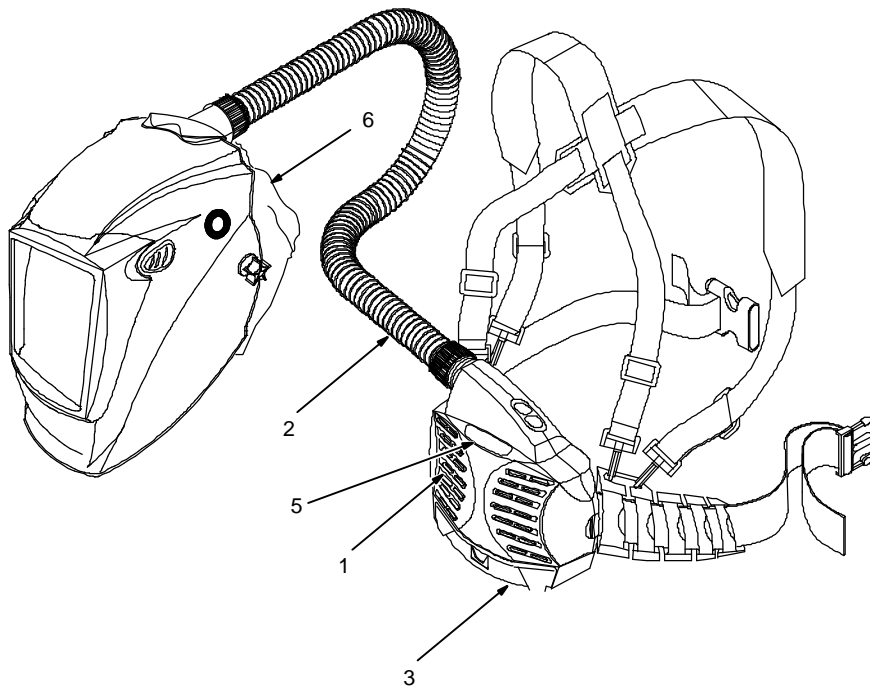

2-12. Putting On The Respirator

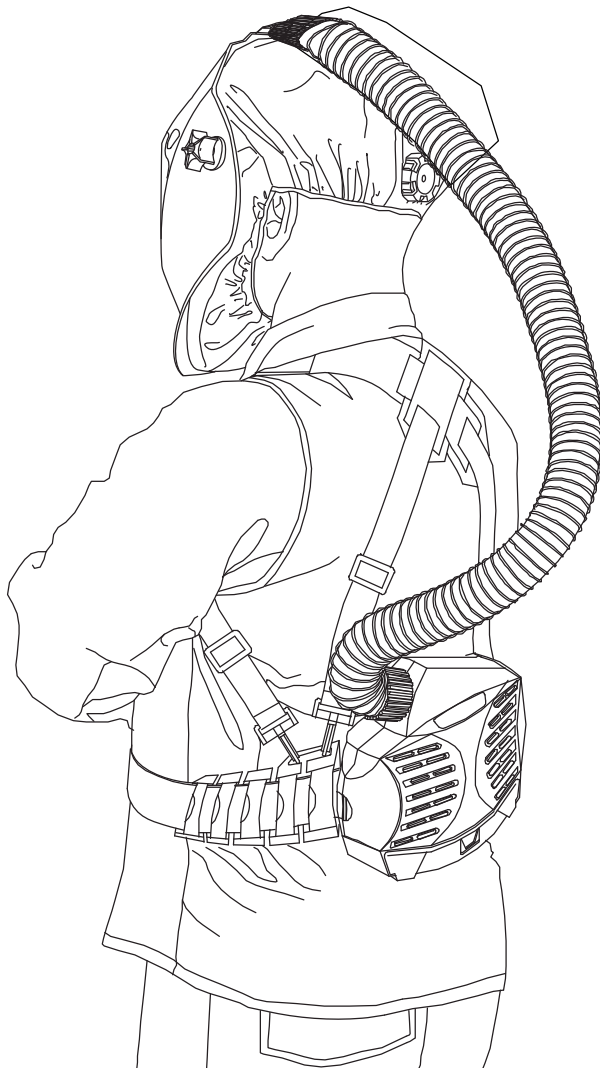
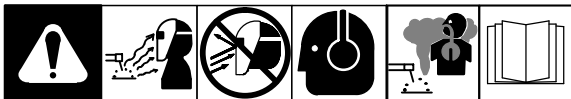

⚠ Do not enter a hazardous area until you are sure the respirator equipment is correctly assembled, working properly, and properly worn.

⚠ Leave the contaminated area immediately if the Danger light goes On, the alarm sounds, or the blower vibrates. Do not remove the equipment until you are in a safe area.

ℹ See Parts List in Section 5 for optional belt extension.

Place blower assembly against lower back with breathing tube extending upwards. Slide straps over shoulders and fasten belt around waist. Adjust straps and belt so unit rests comfortably against lower back.

Put on head assembly. Adjust head assembly to fit snugly on head. Tighten hood drawstring (if equipped) to establish a tight seal around head.

805 187

2-13. Maintenance And Storage

⚠ Replace damaged or dirty air filters. Do not wash filters, clean with compressed air, or reuse dirty air filters.

⚠ Never use solvents or abrasive cleaning solutions to clean the respirator. Keep water and other fluids out of blower assembly.

ℹ Maintain accurate records of filter replacement and respirator maintenance.

For best performance clean the equipment after each use. Use a soft cloth dampened with a mild soap and water solution to wipe all external surfaces clean. Allow to air dry.

Product usage, workplace contamination levels, and other factors affect the life of the filter elements. Replace filter elements if air flow is reduced due to a dirty filter (see Section 2-4) and according to the filter change schedule established by your Safety Director and an Industrial Hygienist.

Inspect breathing tube and replace if damaged or if inside of tube is dirty.

If the respirator will not be used for an extended period, remove the filter and battery and store them in a clean, dry, cool place free of solvent-based vapors.

2-14. Respirator Troubleshooting

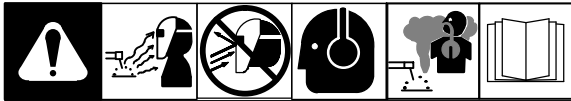

Trouble	Remedy
Blower does not supply air to hood.	Press On button.
	Dead battery; recharge battery (see Section 2-2).
	Verify battery is properly connected to blower body.
	Remove blockage from blower outlet and breathing tube.
Blower cannot be turned Off.	Press Off button for two to three seconds.
Blower runs for short time even though battery is fully charged.	Be sure battery is properly connected to battery charger.
	Replace battery.
	Replace charger.
Battery warning light is On and alarm sounds.	Continue wearing the respirator and leave the contaminated area immediately. Charge or replace the battery. The blower will operate for about 20 minutes after the warning light goes on.
	Have Safety Director and an Industrial Hygienist determine if you are using the proper equipment for the work environment.
Battery run time is too short.	Replace battery.
	Check air filter and replace if necessary (see Sections 2-4 and 2-8). A clogged air filter element reduces battery life.
Danger light is On, alarm sounds or blower vibrates.	Continue wearing the respirator and leave the contaminated area immediately. Check blower air flow (see Sections 2-4 and 2-8).
	Remove blockage from blower outlet and/or breathing tube. If alarm sounds or blower vibrates continuously, contact a Factory Authorized Service Agent.
	Remove packaging from air filter.
	Have Safety Director and an Industrial Hygienist determine if you are using the proper equipment for the work environment.
Air supplied to hood smells and tastes unusual; eyes and throat irritation.	Continue wearing the respirator and leave the contaminated area immediately. Check contamination level of filter, and replace filter if necessary.
	Check breathing tube connections to blower and hood.
	Verify spark guard, prefilter, and particulate (HEPA) filter are installed in blower assembly.
	Have Safety Director and an Industrial Hygienist determine if you are using the proper equipment for the work environment.
Blower supplies insufficient air to hood.	Check breathing tube connections to blower and hood.
	Remove blockage from blower outlet and/or breathing tube.
	Check air filter and replace if necessary (see Sections 2-4 and 2-8). A clogged air filter element reduces battery life.

SECTION 3 – WELDING HELMET HEAD ASSEMBLY

☞ See Section 2 for information on the powered air-purifying respirator (PAPR) assembly. See Section 4 for information on the hard hat head assemblies.

3-1. Specifications

Specification	Titanium 9400/9400i Welding Helmet
Viewing Field	3.81 x 2.62 in (97 x 60mm)
Reaction Time	0.0000500 sec (1/20,000)
Available Shades <i>All Shades Provide Continuous UV And IR Protection.</i>	<p>Weld Mode Darkened State: No. 8 – No. 13 Light State: No. 3</p> <p>Cut Mode Darkened State: No. 5 – No. 8 Light State: No. 3</p> <p>Grind Mode Light State: No. 3</p> <p>X-Mode Darkened State: No. 8 – No. 13 Light State: No. 3</p>
Sensitivity Control	Adjustable For Varying Ambient Light And Welding Arc
Delay Control	Slows Lens Dark-To-Light State Between 0.1 And 1.0 Seconds
Automatic Power Off	Shuts Lens Off 45 Minutes After Last Arc Is Struck
Low Battery Light	Red Led Illuminates To Indicate 2–3 Days Remaining Battery Life
Power Supply	CR2450 Lithium Batteries (Miller Part No. 217 043)
Sensors	Independent/Redundant (Four)
Operating Temperature	14°F to 131°F / –10°C to +55°C ☞ <i>When Stored In Extremely Cold Temperatures, Warm Helmet To Ambient Temperature Before Welding.</i>
Storage Temperature	–4°F to 158°F / –20°C to +70°C ☞ <i>When Stored In Extremely Cold Temperatures, Warm Helmet To Ambient Temperature Before Welding.</i>
Total Weight (Helmet, Lens, Headgear, Head Seal)	Titanium 9400: 28.5 oz (808 g) Titanium 9400i: 33.1 oz (938 g)
Standards	ANSI Z87.1+(2010) and DIN/CSA/TUV
Warranty	Three Years From Date Of Purchase (Section 6)

3-2. Helmet Configurations

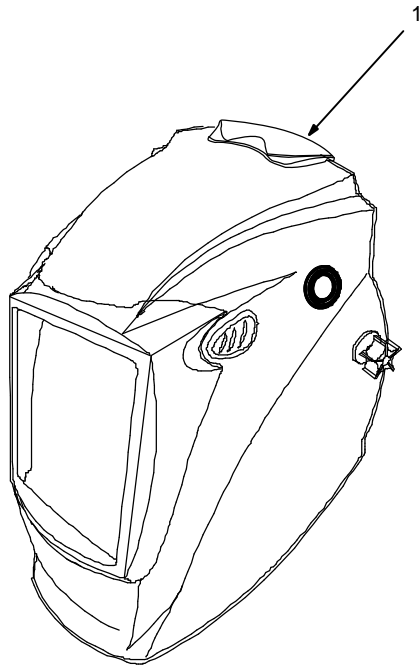

1 Titanium 9400 Helmet

The 9400 helmet features a larger fixed position, auto-darkening lens than the 7300 series and is also designed for standard welding applications.

2 Titanium 9400 Helmet w/ Hard Hat Option

The 9400 helmet includes an ANSI Z89.1 – 2009 Certified, Type 1 – Class C or G approved hard hat and extended length hood.

3 Titanium 9400i Helmet

The 9400i helmet features a flip-up auto-darkening lens and a separate, clear grinding shield. Flip the lens up when grinding and performing other non-welding work. Flip the lens down when welding or cutting.

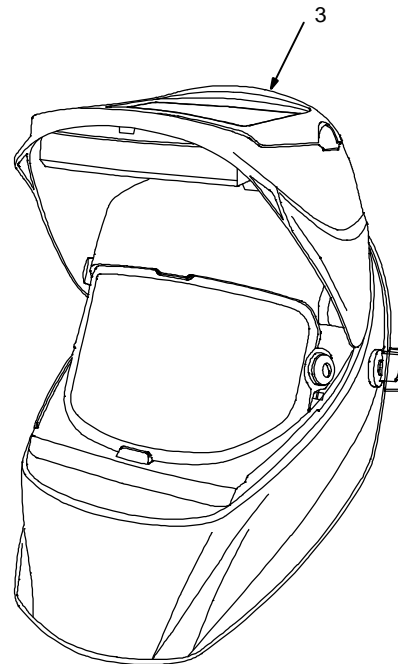
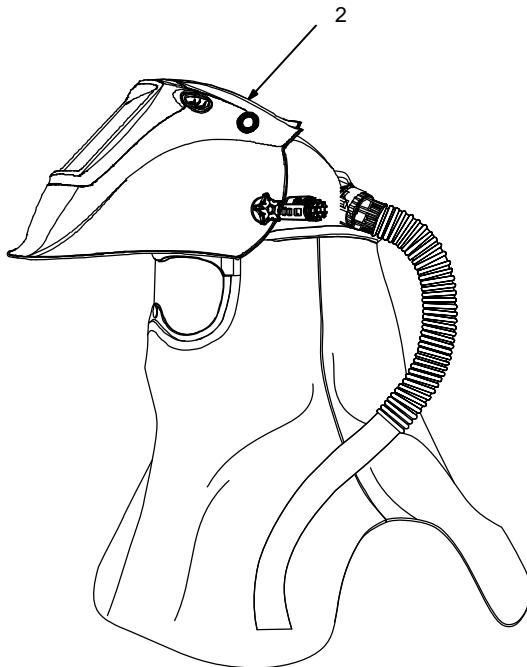

3-3. Helmet Controls

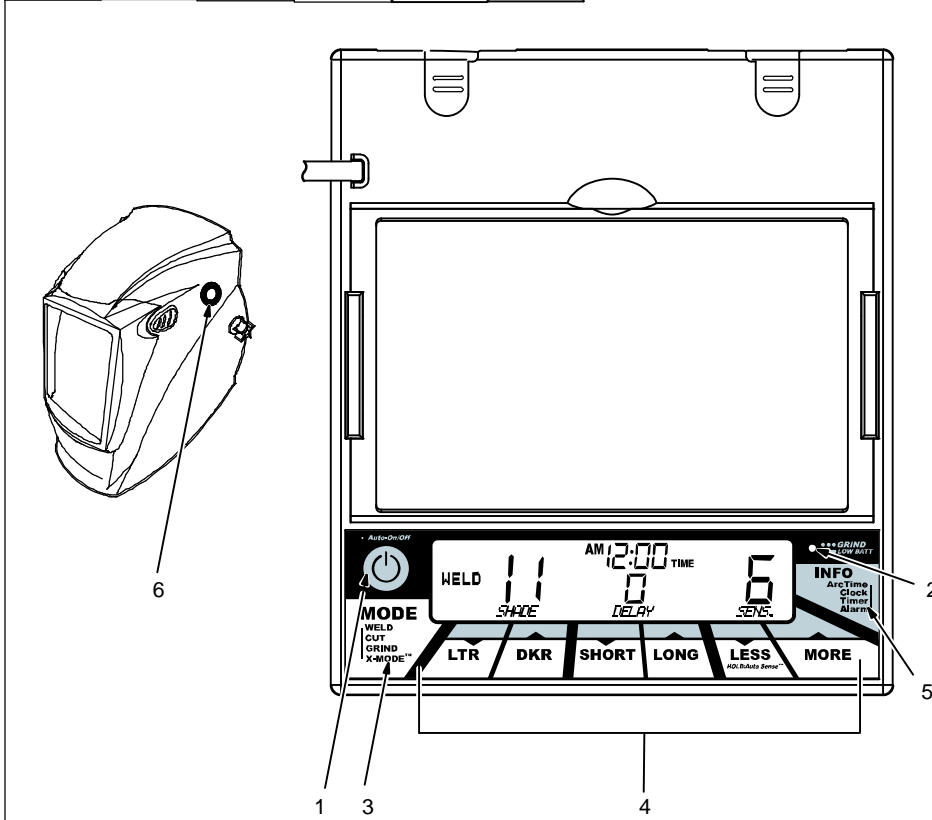
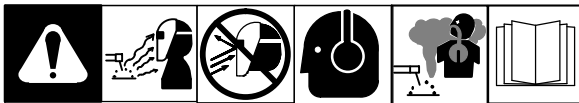

The lens turns on (darkens) automatically when welding begins and turns off when welding stops.

- 1 Auto On/Off Button (See Section 3-4)
- 2 Grind Mode / Low Battery Light (Section 3-4)
- 3 Mode Control Button (Section 3-5)
- 4 Lens/Info Adjustment Buttons (See Sections 3-6 Thru 3-8)

☞ Use adjustment buttons to change shade, delay, and sensitivity settings when lens is in Mode function. Use adjustment buttons to change arc time, clock, timer, and alarm settings when lens is in Info function.

5 Info Control Button (See Section 3-10)

6 External Grind Mode Button (Section 3-5)

☞ The External Grind Mode button is not available on the 9400i helmet.

☞ The lens assembly saves the shade, sensitivity, and delay settings.

3-4. Auto On/Off Button And Grind Mode / Low Battery Light

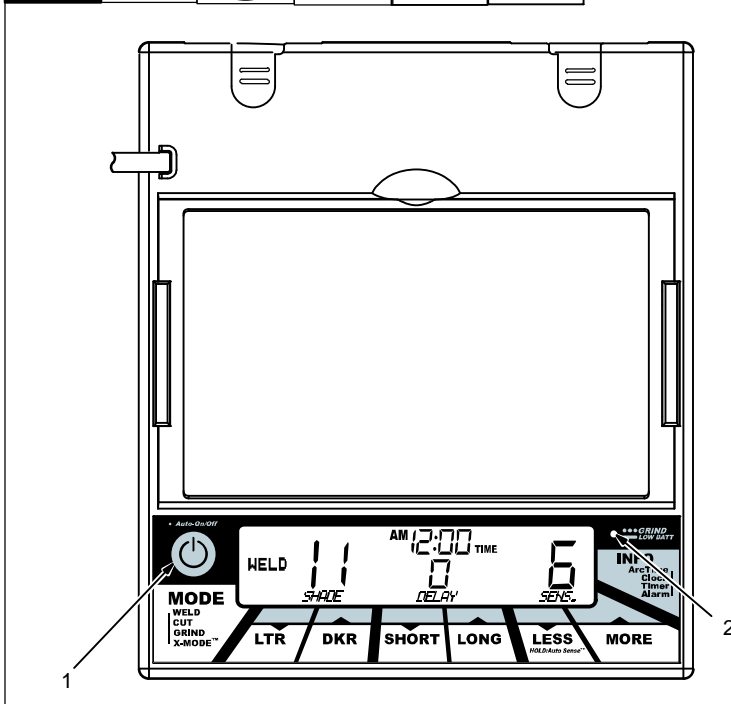
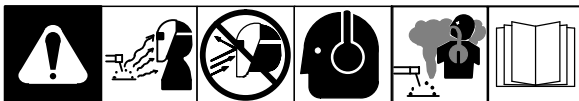

☞ The auto-darkening lens turns on (darkens) automatically when welding begins and turns off when welding stops.

- 1 Auto On/Off Button

Press Auto On/Off button to check if the lens is working properly and to begin Mode and Info adjustments.

When the On/Off button is pressed, the lens should darken and return to the clear state. Do not use the helmet if the lens does not function as described. (See Section 3-21, Troubleshooting.)

- 2 Grind / Low Battery Light

The Grind / Low Battery light blinks when the lens is in the Grind mode. Light stays on when 2–3 days of battery life remain.

If battery power is low, replace with CR2450 lithium batteries (2 required – Miller Part No. 217 043). See Section 3-18.

3-5. Mode Control Button

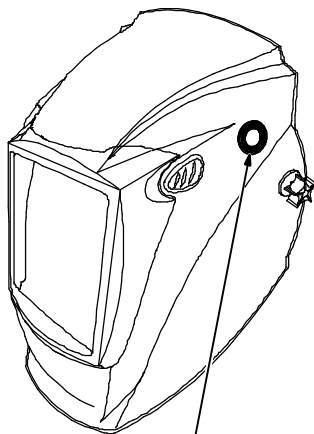
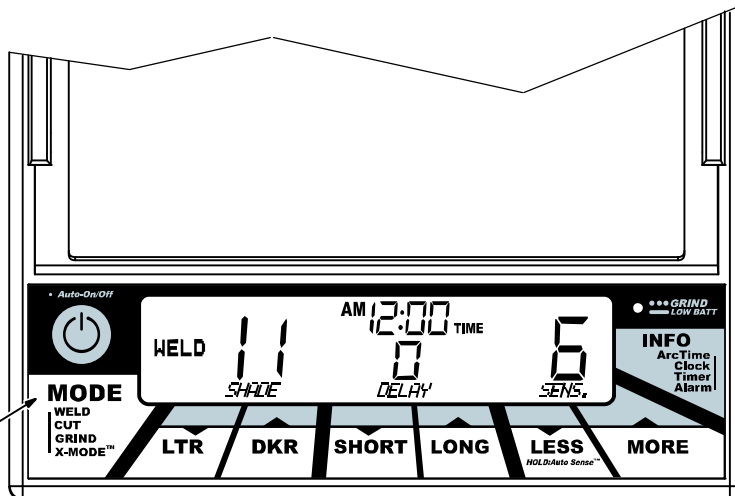

- 1 Mode Control Button
- 2 External Grind Mode Button

Press Mode button to select the mode appropriate for the work activity:

Weld Mode – used for most welding applications. In this mode the lens turns on when it optically senses a welding arc. Adjust shade, sensitivity, and delay settings as needed.

Cut Mode – used for cutting applications. In this mode the lens turns on when it optically senses a cutting arc. Adjust shade, sensitivity, and delay settings as needed.

⚠ If nearby objects may inadvertently contact the external Grind Mode button while you are welding, unplug the Grind Mode button to prevent accidental activation of the Grind mode.

Grind Mode – used for metal grinding applications. In this mode the shade is fixed shade No. 3. No lens adjustments are possible.

Use external Grind Mode button to select grinding mode without raising helmet.

To use Grind mode, push and hold the external Grind button for two seconds. Push Grind mode button again to turn off Grind mode.

X Mode – used for outdoor or low current welding applications. In this mode the lens turns on when it senses weld current. Adjust shade, sensitivity, and delay settings as needed.

ⓘ Nearby welding may affect helmet operation when lens is in X-Mode. Stay at least 12 ft (3.7 m) away from other welding activity.

3-6. Variable Shade Control

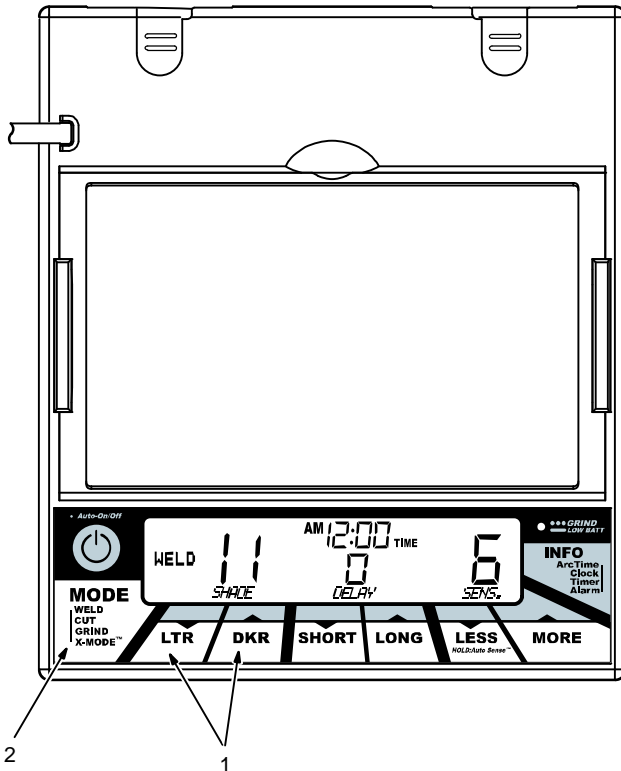
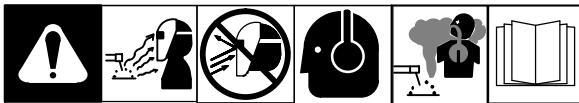

- 1 Variable Shade Adjustment Buttons
- 2 Mode Control Button

Use the LTR and DKR adjustment buttons to adjust the lens shade in the darkened state. Use the table in Section 1-3 to select proper shade control setting based on your welding process. The shade ranges for each mode are as follows:

Weld – No. 8 – No. 13

Cut – No. 5 – No. 8

Grind – No. 3 only

X Mode – No. 8 – No. 13

Start at the highest setting and adjust lighter to suit the application and your personal preference.

Variable Shade Adjustment Procedure

- Press Auto On/Off button to turn lens On. Helmet lens will darken twice and then clear.
- Press Mode Control Button to select desired function: Weld, Cut, or X-Mode.
- Use LTR and DKR adjustment buttons to select desired shade.
- Begin welding or continue with other lens adjustments.

3-7. Lens Delay Control

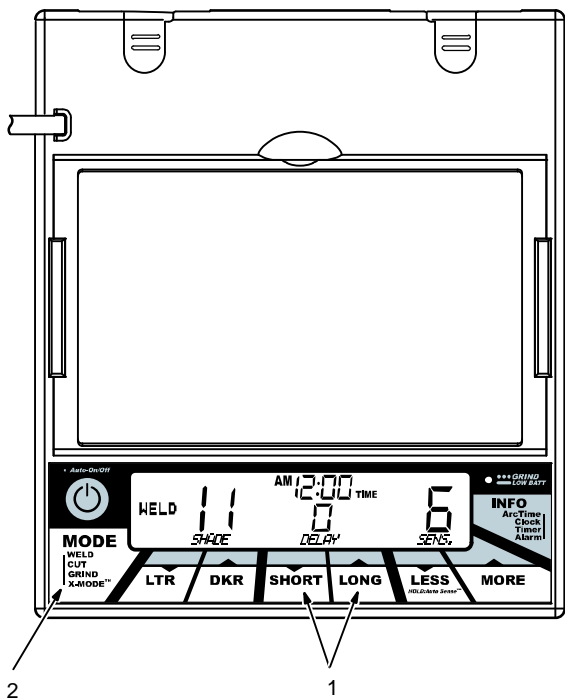

- 1 Lens Delay Adjustment Buttons
- 2 Mode Control Button

Use the Lens Delay Short and Long buttons to adjust the time for the lens to switch to the clear state after welding or cutting.

The delay is particularly useful in eliminating bright after-rays present in higher amperage applications where the molten puddle remains bright momentarily after welding. Use the Lens Delay Control buttons to adjust delay from 0 to 10 (0.1 to 1.0 second).

The delay ranges for each mode are as follows:

Weld, Cut, X Modes – 0 – 10

Grind Mode – No delay adjustment

There is no lens delay adjustment in the Grind mode.

Lens Delay Adjustment Procedure

- Press Auto On/Off button to turn helmet On. Helmet lens will darken twice and then clear.
- Press Mode button to select desired function: Weld, Cut, or X-Mode.
- Use Short and Long adjustment buttons to select desired delay.
- Begin welding or continue with other lens adjustments.

3-8. Sensitivity Control

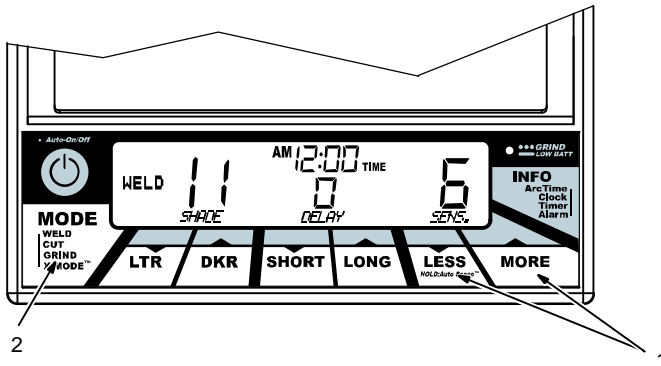

- 1 Sensitivity Adjustment Buttons
- 2 Mode Control Button

Use control to make the lens more responsive to different light levels in various welding processes. Use a **Mid-Range or 30-50% sensitivity setting for most applications.**

It may be necessary to adjust helmet sensitivity to accommodate different lighting conditions or if lens is flashing On and Off.

The sensitivity ranges for each mode are as follows:
Weld, Cut, X Modes – 0 – 10

Grind Mode – No sensitivity adjustment

⚠ Do not weld in the Grind mode; the lens will not darken.

Sensitivity Adjustment Procedure

☞ Adjust helmet sensitivity in lighting conditions helmet will be used in.

- Press Auto On/Off button to turn helmet On. Helmet lens will darken twice and then clear.
- Press Mode button to select desired function: Weld, Cut, or X-Mode.
- Use Sensitivity Less and More buttons to adjust sensitivity control to lowest setting.
- Face the helmet in the direction of use, exposing it to the surrounding light conditions.
- Press sensitivity More button until the lens darkens, then press Less button until lens clears. An alternative method is to press and hold the Less button until the lens clears.

Helmet is ready for use. Slight readjustment may be necessary for certain applications or if lens is flashing on and off.

☞ Reduce Sensitivity setting if lens stays dark longer than Delay setting.

Recommended Sensitivity Settings

Stick Electrode	Mid-Range
Short Circuiting (MIG)	Low/Mid-Range
Pulsed & Spray (MIG)	Mid-Range
Gas Tungsten Arc (TIG)	Mid/High-Range
Plasma Arc Cutting/Welding	Low/Mid-Range

3-9. Typical Lens Adjustment Procedure

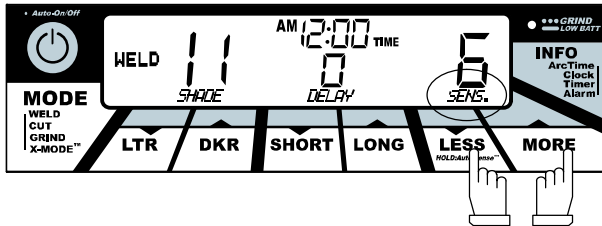
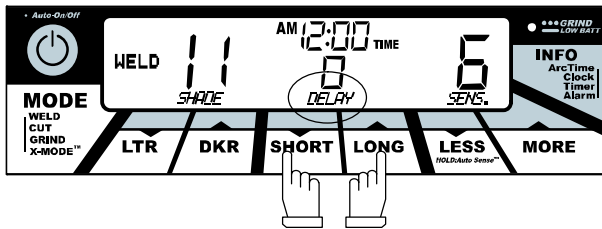
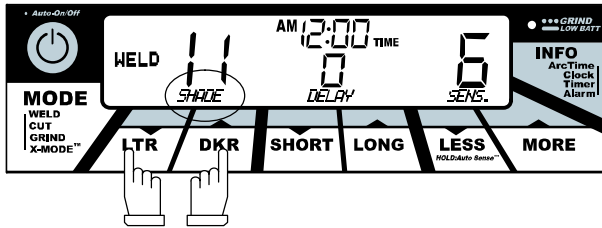
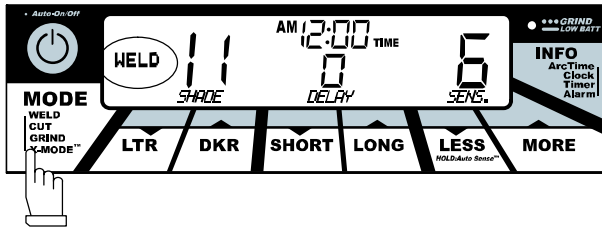
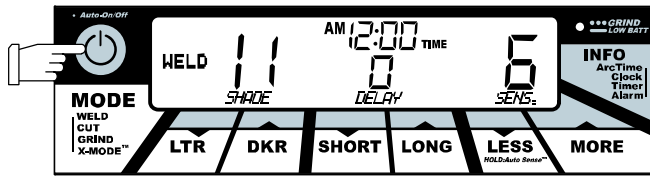

☞ Lens assembly displays prior settings when turned On. Retained settings are not shown in example.

☞ In the Grind mode the lens is a fixed shade No. 3. No lens adjustments are possible.

Adjusting Lens Assembly:

- Turn lens On. Display screen appears.
- Select mode (Weld, Cut, Grind, X-Mode).
- Select shade by pressing LTR and DKR buttons.
- Select Delay by pressing Short and Long buttons.
- Select Sensitivity by pressing Less and More Buttons.
- Begin work.

3-10. Info Control Button

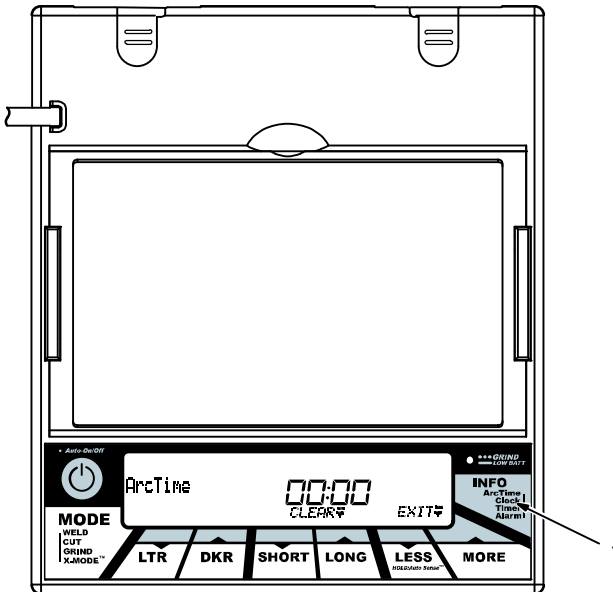
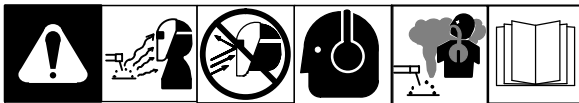

1 Info Control Button

Press button to select from the following functions:

Arc Time – records the amount of time the lens assembly is in the dark state (exposed to arc). See Section 3-11 to reset Arc Time.

Clock – displays actual time of day. See Section 3-12 to set clock.

Timer – emits an audible signal and the Grind mode light flashes to alert the operator after a specific period of time has elapsed. See Section 3-13 to set timer.

Alarm – emits an audible signal and the Grind mode light flashes to alert the operator at a specific time. See Section 3-14 to set alarm.

☞ Lens automatically exits the Info function after 15 seconds of inactivity.

3-11. Arc Time Control

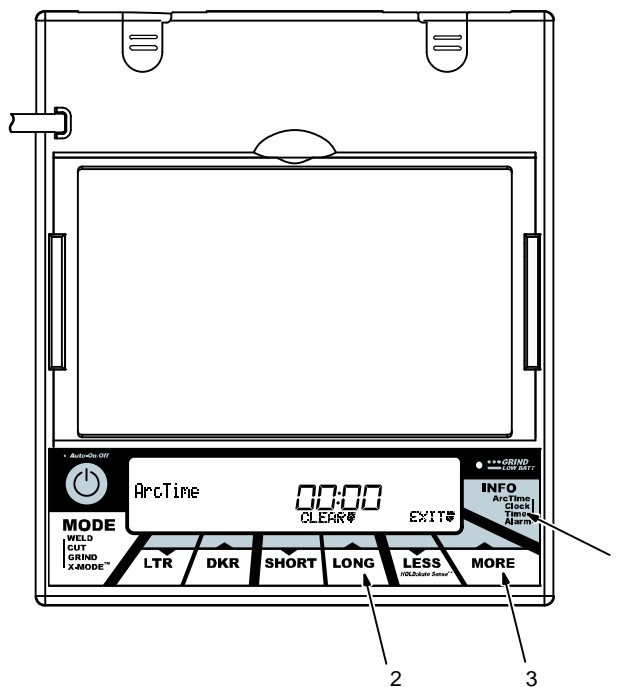
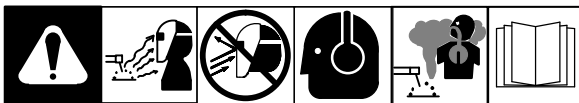

The arc time function records the amount of time the lens assembly is dark (exposed to an arc).

- 1 Info Control Button
- 2 Arc Time Clear Button
- 3 Arc Time Exit Button

Arc Time Procedure

- Press Auto On/Off button to turn helmet On. Helmet lens will darken twice and then clear.
- Press Info button repeatedly until Arc Time is displayed on screen.
- Use the Clear button to reset the arc time to zero.
- Press the Exit button when finished.

3-12. Clock Control

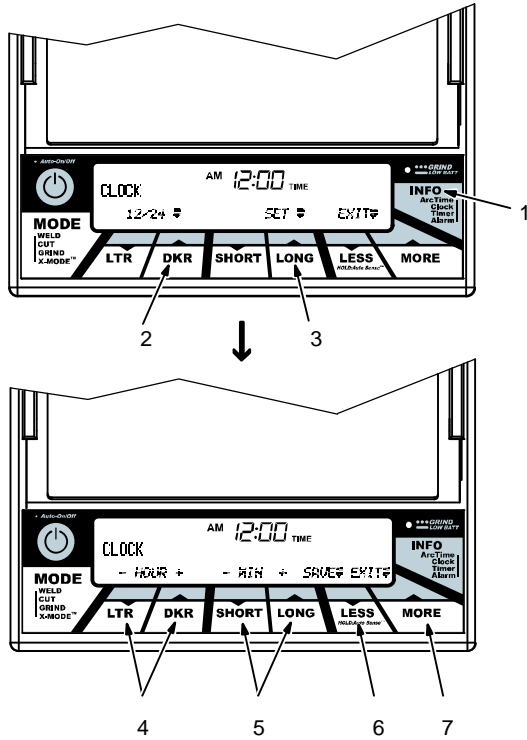
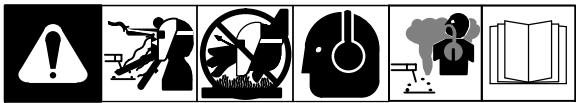

The clock displays the actual time of day.

- 1 Info Control Button
- 2 12/24 Hour Cycle Button
- 3 Clock Set Button
- 4 Hour +/- Buttons
- 5 Minute +/- Buttons
- 6 Save Button
- 7 Exit Button

Clock Procedure

- Press Auto On/Off button to turn helmet On. Helmet lens will darken twice and then clear.
- Press Info button repeatedly until Clock is displayed on screen.
- Press 12/24 button to select either 12 or 24 hour clock format.
- Press the Set button to enter set mode.
- Press Hour +/- buttons to change hour setting.
- Press Minute +/- buttons to change minute setting.
- Press Save button.
- Press the Exit button when finished.

3-13. Timer Control

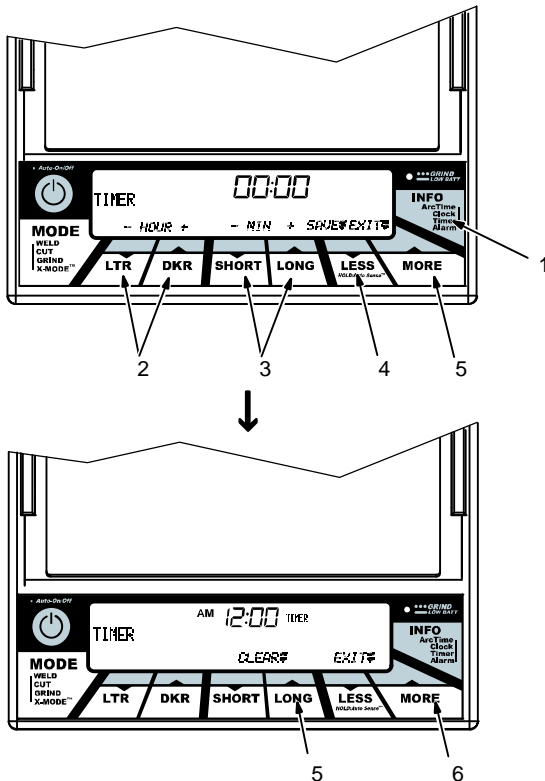
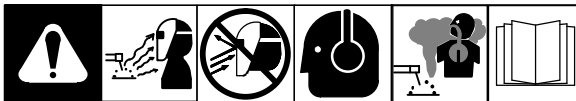

The Timer emits an audible signal and the Grind mode light flashes to alert the operator after a specific period of time has elapsed.

- 1 Info Control Button
- 2 Hour +/- Buttons
- 3 Minute +/- Buttons
- 4 Save Button
- 5 Clear Button
- 6 Exit Button

Arc Time Procedure

- Press Auto On/Off button to turn helmet On. Helmet lens will darken twice and then clear.
- Press Info Control button repeatedly until Timer is displayed on screen.
- Press Hour +/- buttons to change hour setting.
- Press Minute +/- buttons to change minute setting.
- Press Save button.
- Press the Clear button to start over, or press the Exit button when finished.

Press External Grind Mode button or any lens button to turn off alarm.

3-14. Alarm Control

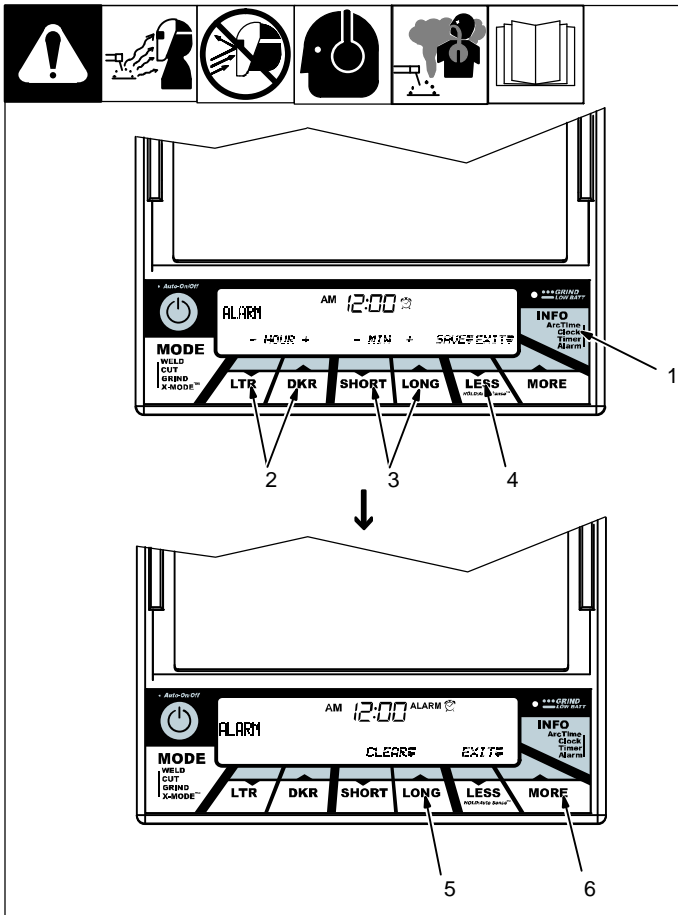

The Alarm emits an audible signal and the Grind mode light flashes to alert the operator at a specific time.

- 1 Info Control Button
- 2 Hour +/- Buttons
- 3 Minute +/- Buttons
- 4 Save Button
- 5 Clear Button
- 6 Exit Button

Timer Procedure

- Press Auto On/Off button to turn helmet On. Helmet lens will darken twice and then clear.
- Press Info button repeatedly until Alarm is displayed on screen.
- Press Hour +/- buttons to change hour setting.
- Press Minute +/- buttons to change minute setting.
- Press Save button.
- Press the Clear button to start over, or press the Exit button if finished.

☞ Press External Grind Mode button or any lens button to turn off alarm.

3-15. Adjusting Headgear

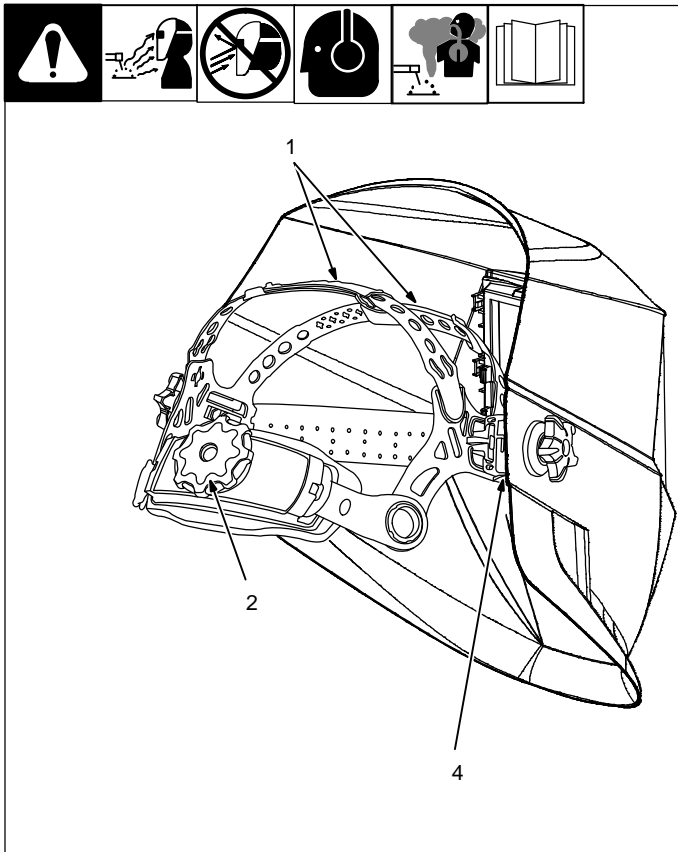

☞ See Section 4-3 for information on adjusting helmet equipped with hard hat option.

☞ There are four headgear adjustments: headgear top, tightness, angle adjustment, and distance adjustment.

1 Headgear Top

Adjusts headgear for proper depth on the head to ensure correct balance and stability.

2 Headgear Tightness

To adjust, turn the adjusting knob (located on the back of the headgear) left or right to desired tightness.

3 Angle Adjustment (Not Shown)

Seven slots on the right side of the headband provide adjustment for the forward tilt of the helmet. To adjust, lift and reposition the control arm to the desired position.

4 Distance Adjustment

Adjusts the distance between the face and the lens. To adjust, press black tabs on the top and bottom of the pivot point and use other hand to slide headgear forward or backward. Release tabs. (Both sides must be equally positioned for proper vision.)

☞ Numbers on the adjustment slides indicate set position so both sides can be adjusted equally.

3-16. Replacing Lens Covers

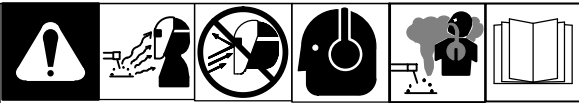

⚠ Never use the auto-darkening lens without the inside and outside lens covers properly installed. Welding spatter will damage the auto-darkening lens and void the warranty.

Outside Lens Cover

- 1 Lens Holder
- 2 Release Points
- 3 Outside Lens Cover

Remove lens holder by pressing release points and pulling the holder away from the helmet.

Remove lens cover from holder. Replace lens cover in lens holder. Reinstall lens holder in helmet.

Inside Lens Cover

- 4 Gasket
- 5 Lens Assembly
- 6 Inside Lens Cover

Remove the inside lens cover by prying cover from groove in gasket.

Replace the lens cover by gently bowing it in the center and inserting it, one end at a time, into the gasket.

☞ Be sure the cover lens is seated properly (flat) to prevent fogging.

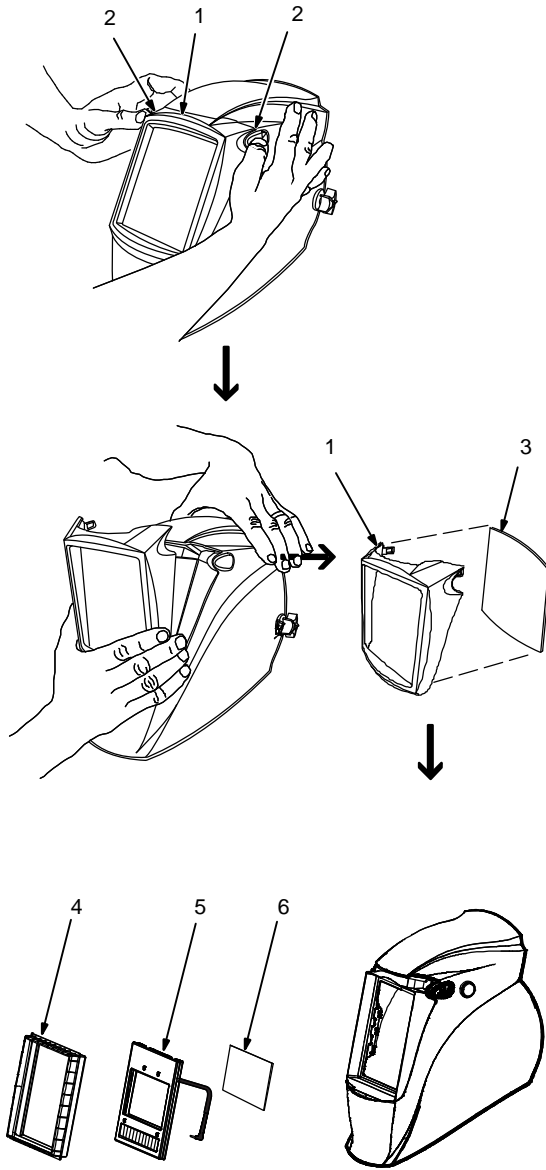

3-17. Replacing Grinding Shield On Titanium 9400i Helmet

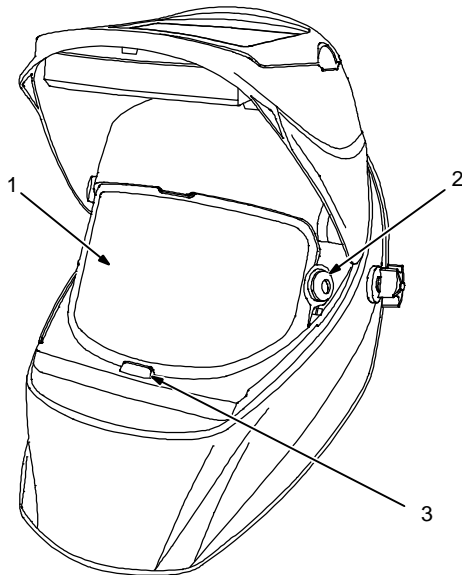

⚠ Never use the auto-darkening lens without the inside and outside lens covers properly installed. Welding spatter will damage the auto-darkening lens and void the warranty.

- 1 Grinding Shield
- 2 Retaining Clip
- 3 Tab

Rotate both retaining clips to the Open position.

Gently push shield toward bottom tab and remove shield from helmet.

Remove retaining clips from shield. Install clips in same location on new shield. (Retaining clips are not interchangeable.)

Install new shield in helmet and rotate clips to the Lock position.

Ref. 804 109

3-18. Replacing The Battery

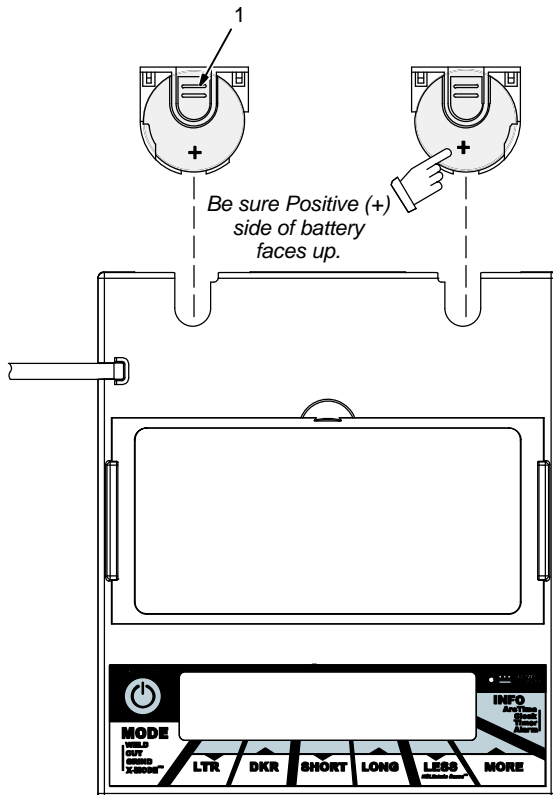

To replace the batteries, remove the auto-darkening lens assembly (see Section 3-16).

- 1 Battery Tray

After removing the lens assembly, slide the battery holding trays out and remove the old batteries.

Replace with CR2450 lithium type batteries (2 required) or equivalent (Miller Part No. 217043).

☞ Be sure Positive (+) side of the battery faces up (toward inside of helmet).

Reinstall the battery trays. To test battery, press the Auto On/Off button. The display screen should turn on. Reinstall the lens assembly.

☞ Left and right battery trays are not interchangeable. The auto-darkening helmet will not work if battery trays are installed on the wrong sides.

3-19. Installing Optional Magnifying Lens

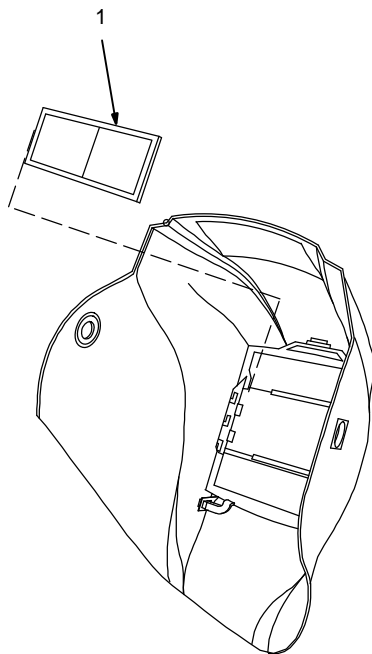

1 Optional Magnifying Lens

Starting at the bottom, slide magnifying lens into the helmet retaining brackets. Align the magnifying lens with the auto-darkening lens assembly.

- Remove lens holding frame (with auto-darkening lens) from helmet shell.
- Remove auto-darkening lens from lens holder.
- Position lens holder with magnifying lens holding tabs facing toward you. From the bottom up, slide magnifying lens into position. (Slide magnifying lens up or down slightly as desired.)
- Reinstall the auto-darkening lens in the lens holder.
- Reverse procedure to remove magnifying lens.

 To prevent lens fogging, install flat side of magnifying lens toward auto-darkening lens.

804 818

3-20. Maintenance

NOTICE – Never use solvents or abrasive cleaning detergents. Do not immerse the lens assembly in water.

The helmet requires little maintenance. However, for best performance clean after each use. Using a soft cloth dampened with a mild soap and water solution, wipe the cover lenses clean. Allow to air dry. Occasionally, the filter lens and sensors should be cleaned by gently wiping with a soft, dry cloth.

Notes

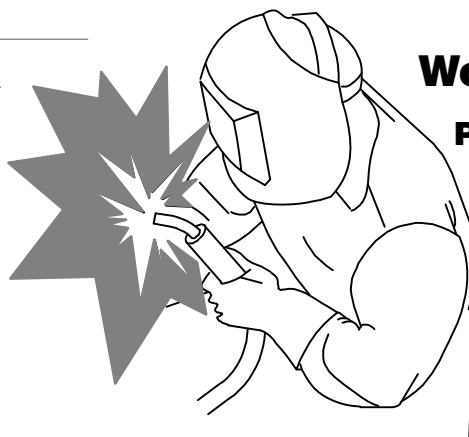

Work like a Pro!

Pros weld and cut safely. Read the safety rules at the beginning of this manual.

3-21. Troubleshooting

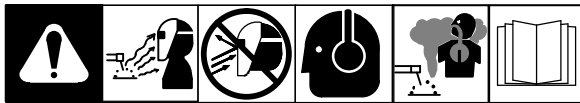

Trouble	Remedy
Auto lens not ON – auto-lens will not darken momentarily when the Reset button is pressed.	Check batteries and verify they are in good condition and installed properly. Also, check battery surfaces and contacts and clean if necessary. Check battery for proper contact and gently adjust contact points if necessary. This is particularly important if the helmet has been dropped. Verify left and right battery trays are installed on the correct sides.
Not switching – auto-lens stays light and will not darken when welding.	Stop welding immediately: Press the Reset button if lens is Auto-On type. If lens is Manual-On type, make sure the lens is turned On. If power is on, review the sensitivity recommendations and adjust sensitivity. Clean lens cover and sensors of any obstructions. Make sure the sensors are facing the arc; angles of 45° or more may not allow the arc light to reach the sensors.
Not Switching – auto-lens stays dark after the weld arc is extinguished, or the auto-lens stays dark when no arc is present.	Fine-tune the sensitivity setting by making small adjustments to the control by turning it toward the “min” setting. In extreme light conditions, it may be necessary to reduce the surrounding light levels.
Sections of the auto-lens are not going dark, distinct lines separate the light and dark areas.	Stop welding immediately: The auto-lens may be cracked which can be caused by the impact of dropping the helmet. Weld spatter on the auto lens may also cause cracking. (The lens may need to be replaced; most cracked lenses are not covered by warranty).
Switching or Flickering – the auto-lens darkens then lightens while the welding arc is present.	Review the sensitivity setting recommendations and increase the sensitivity if possible. Be sure the arc sensors are not being blocked from direct access to the arc light. Check the lens cover for dirt and spatter that may be blocking the arc sensors. Increasing Lens Delay 0.1 – 0.3 second may also reduce switching.
Inconsistent or lighter auto-lens shading in the dark-state, noticeable on the outside edges and corners.	Referred to as an angle of view effect, auto-darkening lenses have an optimum viewing angle. The optimum viewing angle is perpendicular or 90° to the surface of the auto-lens. When that angle of view varies in the dark-state, welders may notice slightly lighter areas at the outside edges and the corners of the lens. This is normal and does not represent any health or safety hazard. This effect may also be more noticeable in applications where magnifying lenses are used.

Notes

SECTION 4 – HARD HAT HEAD ASSEMBLY

⚠ This equipment helps protect the user from certain contaminants. All users must read and understand these instructions and be trained in the proper use of this equipment before using. Use this equipment according to all applicable health and safety standards. If you have questions about the type of respiratory equipment required, consult your safety director and an Industrial Hygienist.

⚠ Do not enter a hazardous area until you are sure the respirator equipment is correctly assembled, working properly, and properly worn.

📖 See Section 2 for information on the powered air-purifying respirator (PAPR assembly. See Section 3 for information on the welding helmet head assemblies.

4-1. Specifications

Specification	Hard Hat Head Assemblies
Viewing Field	3.81 x 2.62 in (97 x 60mm)
Total Weight	Hard Hat Head Assembly: 32.3 oz (916 g) Hard Hat With Titanium 9400 Helmet Head Assembly: 51.2 oz (1452 g) Hard Hat With Titanium 9400i Helmet Head Assembly: 55.4 oz (1571 g)
Standards (Hard Hat)	ANSI Z89.1 – 2009 Certified, Type 1 – Class C Or G Approved
Warranty (Hard Hat)	30 Days From Date Of Purchase

4-2. Attaching Welding Helmet To Hard Hat

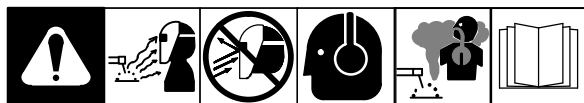

- 1 Hardhat Tab
- 2 Helmet Receiver
- 3 Distance Adjustment Levers

Align hardhat tabs with receivers on headgear. Slide tabs forward into receivers until tabs click into desired positions.

To remove hardhat, press both distance adjustment levers and pull helmet away from hardhat.

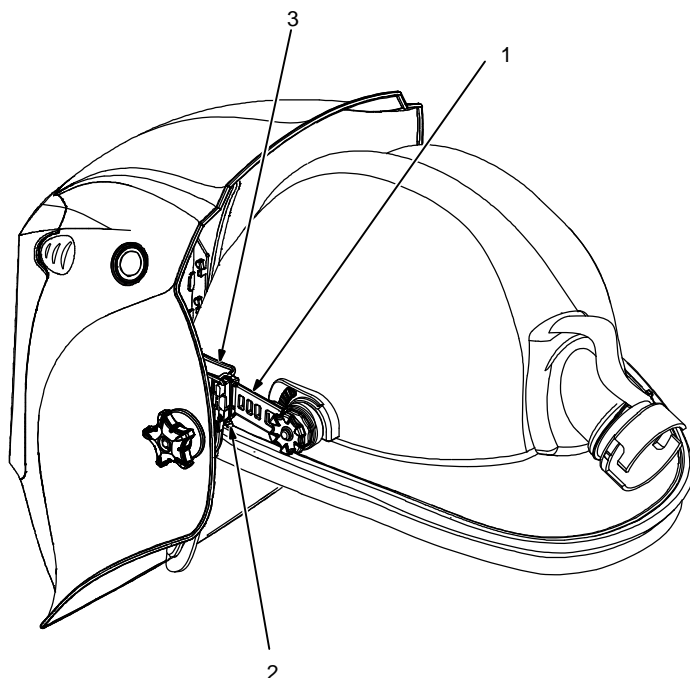

4-3. Adjusting Hard Hat Headgear

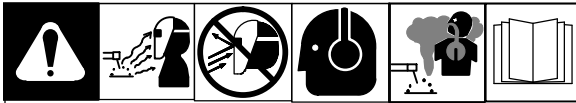

☞ There are three hardhat adjustments: hardhat tightness, angle adjustment, and distance adjustment.

1 Headgear Tightness

To adjust, turn the adjusting knob (located on the back of the headgear) left or right to desired tightness.

2 Distance Adjustment Levers

This adjustment changes the distance between the face and the lens. To adjust, press both distance levers and helmet forward or back to desired position. Release levers. (Both sides must be equally positioned for proper vision.)

3 Angle Adjustment

Four notches on each side of the headband provide adjustment for the forward tilt of the helmet. To adjust, loosen the outside tension adjustment knobs then move the helmet to the desired position. Retighten tension adjustment knobs.

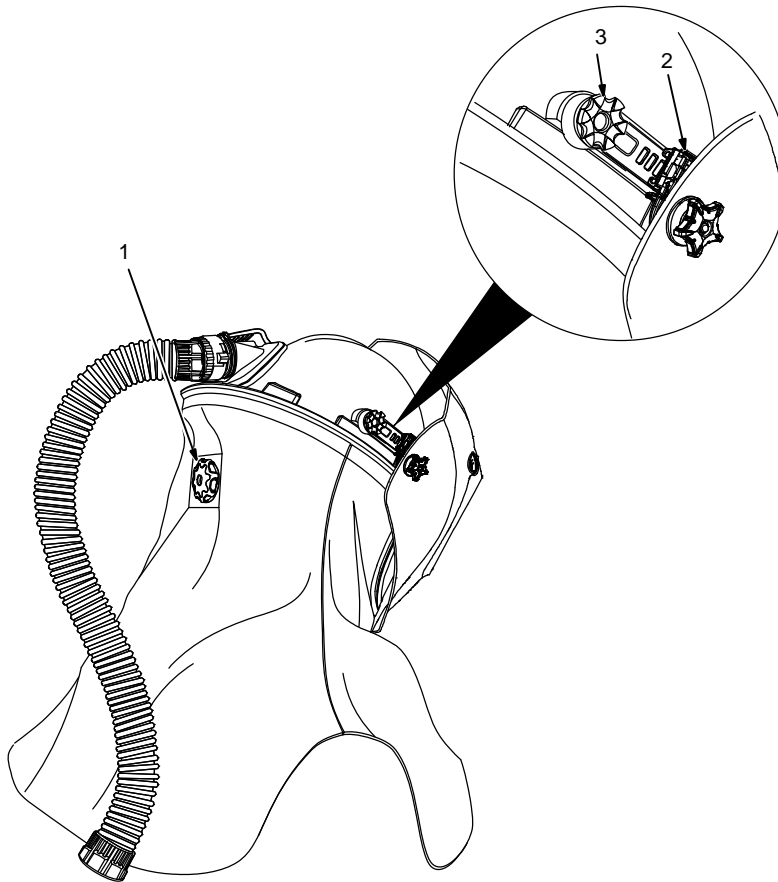

4-4. Replacing Hard Hat Lens



⚠ Never use the hard hat unless lens is properly installed.

- 1 Snaps
- 2 Lens
- 3 Gasket

Loosen top and bottom snaps securing lens in holder.

Remove lens by prying bottom of lens from groove in gasket.

Install new lens by inserting lens in groove at top of gasket. Carefully guide lens into remainder of gasket. Align holes in lens with snaps in gasket.

Press (close) snaps to secure lens.

☞ Be sure the lens is seated properly (in gasket) to prevent fogging.

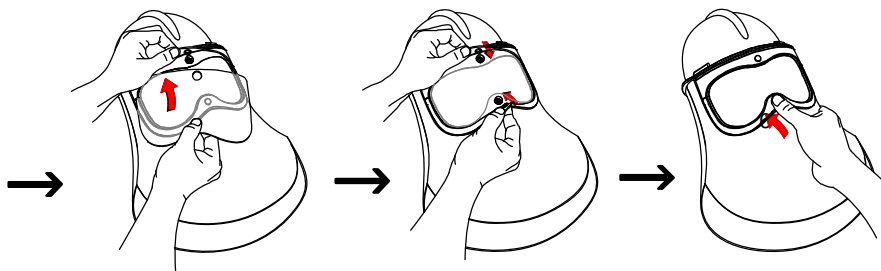
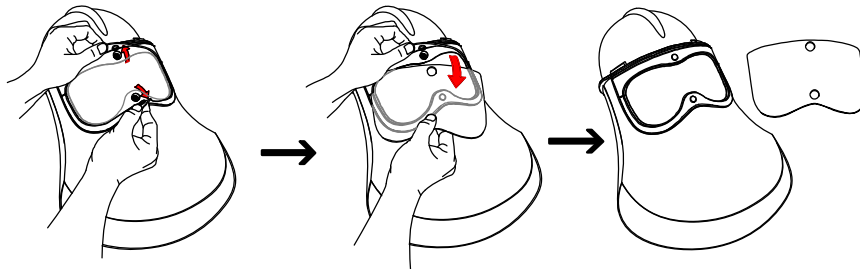
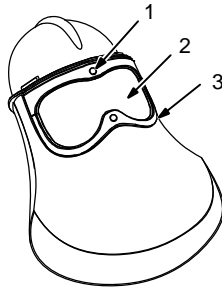

Notes

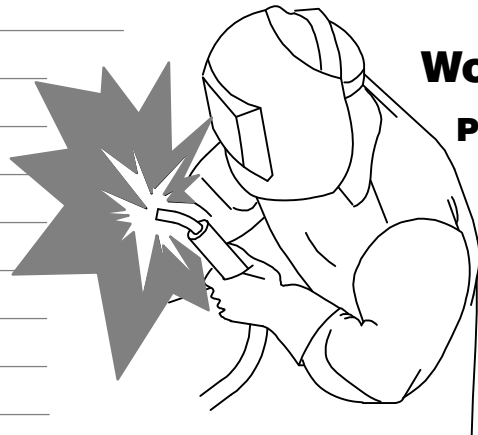

Work like a Pro!
Pros weld and cut safely. Read the safety rules at the beginning of this manual.

SECTION 5 – PARTS LIST

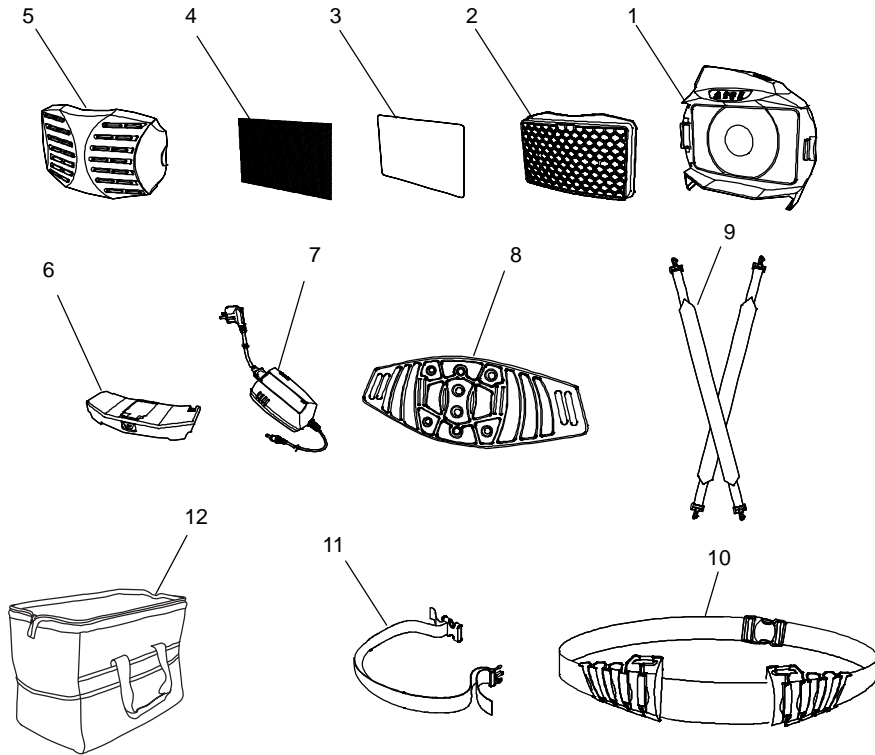

805 193 / Ref. 805 068 / Ref 804 111 / 242 385

Figure 5-1. Powered Air Purifying Respirator (PAPR) Blower Assembly

Item No.	Part No.	Description	Quantity
Figure 5-1. Powered Air Purifying Respirator (PAPR) Blower Assembly			
1	235672	Blower Assembly	1
2	235673-2	Filter, Particulate (HEPA) (2-Pack)	1
	235673-6	Filter, Particulate (HEPA) (6-Pack)	1
	235673-36	Filter, Particulate (HEPA) (36-Pack)	1
3	235674	Filter, Prefilter (Foam)	1
	◆268841	Filter, Prefilter Nuisance Level OV Relief (Not Shown)	1
4	235676	Spark Guard	1
5	235677	Filter Cover	1
6	244131	Battery, Blower	1
7	244132	Charger	1
8	239636	Belt Pad (PAPR)	1
9	235680	Shoulder Straps	1
10	235679	Belt	1
11	◆244151	Belt Extension	1
12	228028	Bag	1

◆Optional

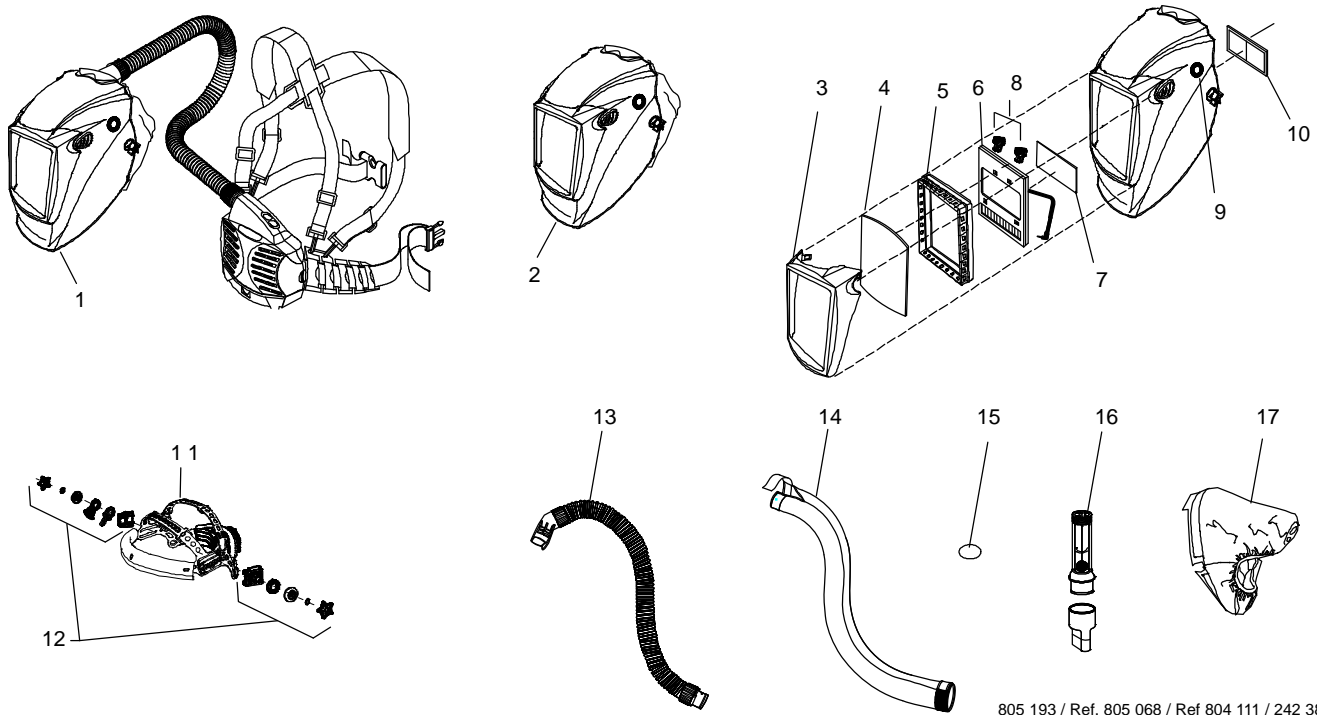

805 193 / Ref. 805 068 / Ref 804 111 / 242 385

**Figure 5-2. Powered Air Purifying Respirator (PAPR)
Titanium 9400™ Head Assembly**

Item No.	Dia. Mkgs.	Part No.	Description	Quantity
Figure 5-2. Powered Air Purifying Respirator (PAPR) Titanium 9400™ Head Assembly				
1		264879	PAPR (Complete System)	1
		264882	PAPR (System Without Auto-Dark Lens Assembly)	1
2		264883	Helmet Assembly (Includes Helmet, Headgear And FR Head Seal)	1
3		243396	Lens Holder, Front	1
4		216326	Lens Cover, Outside (4-11/16 X 5-5/8) (5 Per Pkg.)	1
5		241977	Gasket, Lens Assembly	1
6		256359	Lens Assembly, Auto-Darkening, Infotrack, EX	1
7		216327	Lens Cover, Inside (4-1/4 X 2-1/2) (5 Per Pkg.)	1
8		216339	Kit, Battery Tray (Left/Right)	1
		217043	Battery, Lithium (CR2450)	2
9		256179	External Grind Button	1
10		◆212235	Lens, 0.75 Magnification	1
		◆212236	Lens, 1.00 Magnification	1
		◆212237	Lens, 1.25 Magnification	1
		◆212238	Lens, 1.50 Magnification	1
		◆212239	Lens, 1.75 Magnification	1
		◆212240	Lens, 2.00 Magnification	1
		◆212241	Lens, 2.25 Magnification	1
		◆212242	Lens, 2.50 Magnification	1
11		256174	Headgear Gray (Includes)	1
12		256178	Kit, Adjustment Angle/Stop Hardware	1
		770249	Headband, Fabric	1
		079975	Replacement O-rings For Kit 770 248 (5 Per Pkg.)	1
13		245218	Breathing Tube Assembly	1
14		245367	FR Breathing Tube Cover	1
15		237452	Breathing Tube O-Ring	1
16		245219	Flowmeter	1
17		265629	FR Head Seal (Hood)	1

◆ Optional

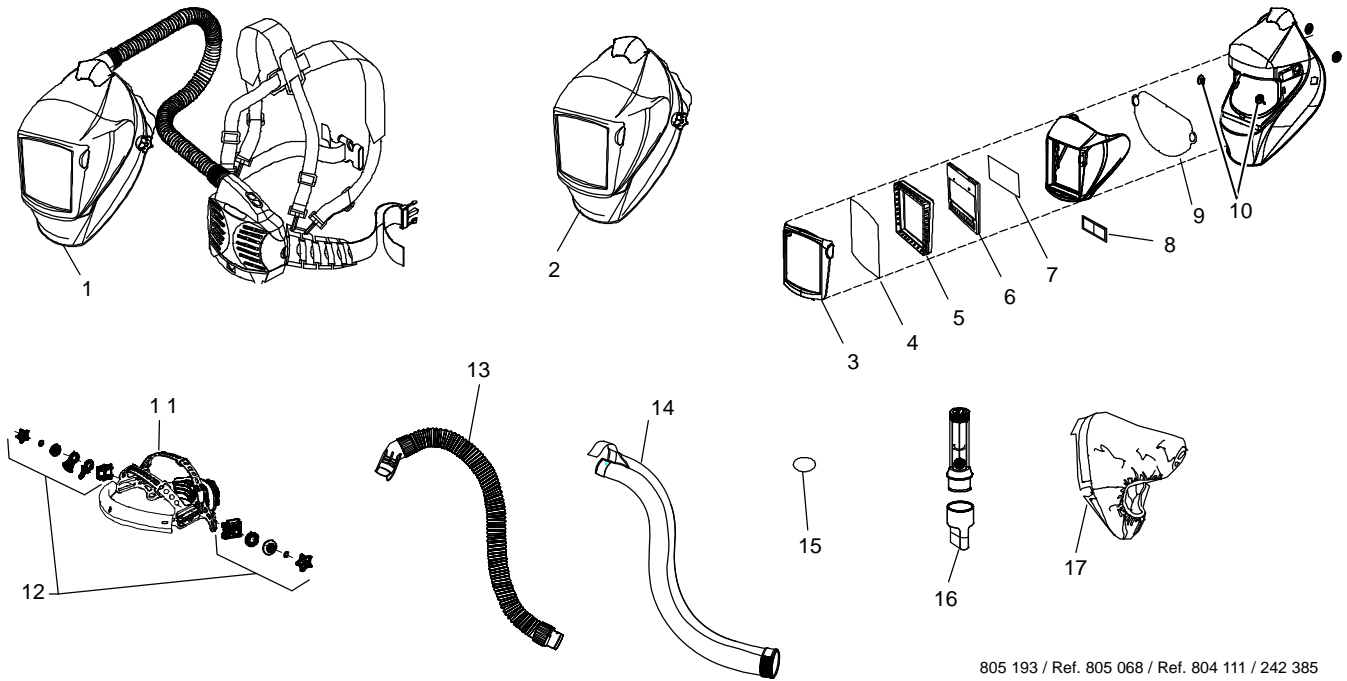

805 193 / Ref. 805 068 / Ref. 804 111 / 242 385

**Figure 5-3. Powered Air Purifying Respirator (PAPR)
Titanium 9400i™ Head Assembly**

Item No.	Part No.	Description	Quantity
Figure 5-3. Powered Air Purifying Respirator (PAPR) Titanium 9400i™ Head Assembly			
1	264877	PAPR (Complete System)	1
	264878	PAPR (System Without Auto-Dark Lens Assembly)	1
2	264884	Helmet Assembly (Includes Helmet, Headgear And FR Head Seal)	1
3	245815	Lens Holder, Front	1
4	216326	Lens Cover, Outside (4-11/16 X 5-5/8) (5 Per Pkg.)	1
5	241977	Gasket, Lens Assembly	1
6	256360	Lens Assembly, Auto-Darkening Infotrack	1
	217043	Battery, Lithium (CR2450)	2
7	216327	Lens Cover, Inside (4-1/4 X 2-1/2) (5 Per Pkg.)	1
8	◆212235	Lens, 0.75 Magnification	1
	◆212236	Lens, 1.00 Magnification	1
	◆212237	Lens, 1.25 Magnification	1
	◆212238	Lens, 1.50 Magnification	1
	◆212239	Lens, 1.75 Magnification	1
	◆212240	Lens, 2.00 Magnification	1
	◆212241	Lens, 2.25 Magnification	1
	◆212242	Lens, 2.50 Magnification	1
9	245818	Lens, Grinding Shield	1
10	245819	Clip, Retaining Grinding Shield	1
11	256174	Headgear Gray (Includes)	1
12	256178	Kit, Adjustment Angle/Stop Hardware	1
	770249	Headband, Fabric	1
	079975	Replacement O-rings For Kit 770 248 (5 Per Pkg.)	1
13	245218	Breathing Tube Assembly	1
14	245367	FR Breathing Tube Cover	1
15	237452	Breathing Tube O-Ring	1
16	245219	Flowmeter	1
17	265628	FR Head Seal (Hood)	1
	◆254278	Tear-Away Grinding Shield Covers	1

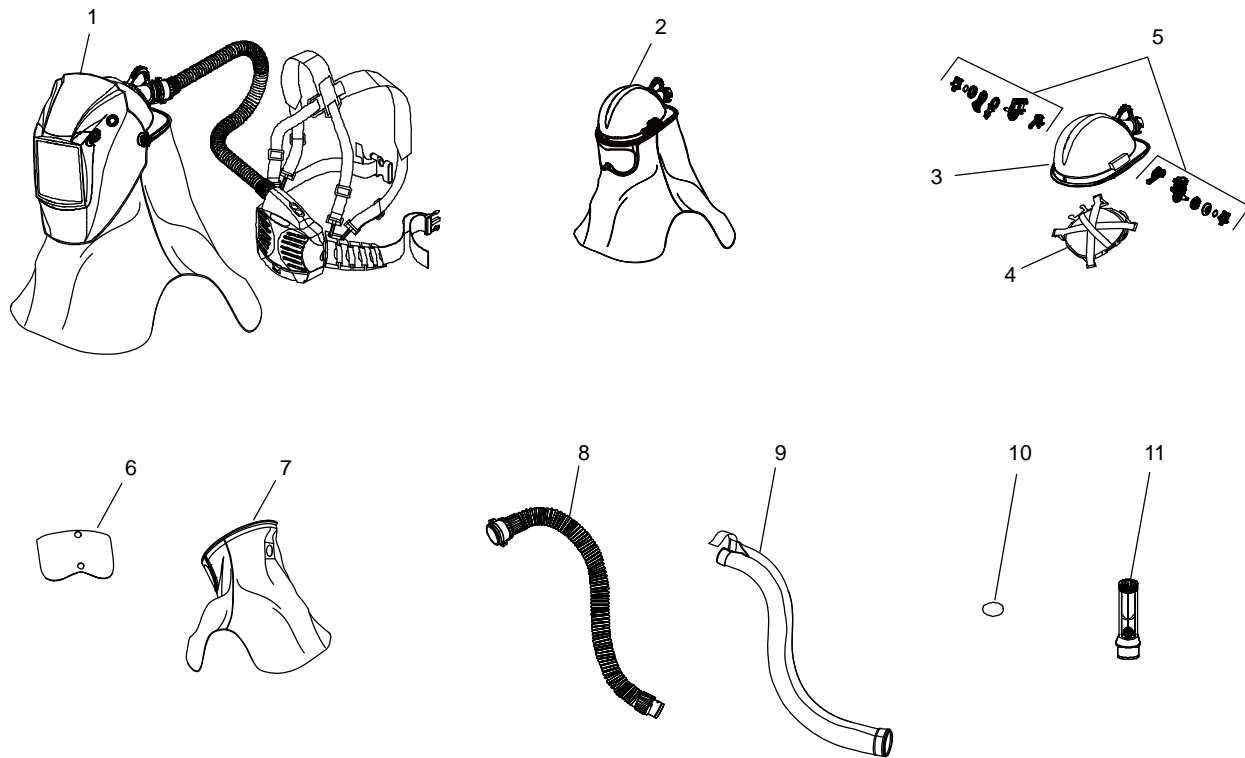

**Figure 5-4. Powered Air Purifying Respirator (PAPR)
Hard Hat Head Assembly**

Item No.	Part No.	Description	Quantity
Figure 5-4. Powered Air Purifying Respirator (PAPR) Hard Hat Head Assembly			
1	259385	PAPR (Complete System With Hard Hat & Titanium 9400 Helmet)	1
	261659	PAPR (Complete System With Hard Hat & Titanium 9400i Helmet)	1
	259386	PAPR (Complete System With Hard Hat)	1
2	259387	Helmet Assembly (Including Headgear, Head Seal, And Hard Hat)	1
3	259460	Hard Hat (With Air Ducts)	1
4	259388	Headgear, Hard Hat	1
5	259637	Slotted Hard Hat Adapter, Quick Release	1
6	259390	Lens, Clear Shield (Hard Hat)	1
	259391	Lens Cover, Tear Off Sheets (Hard Hat)	1
7	259389	FR Head Seal (Hood)	1
8	259392	Breathing Tube Assembly	1
9	239571	FR Breathing Tube Cover	1
10	259394	O-Ring, Breathing Tube	1
11	260890	Flowmeter	1

☞ See Figure 5-5 for optional hard-hat head accessories.

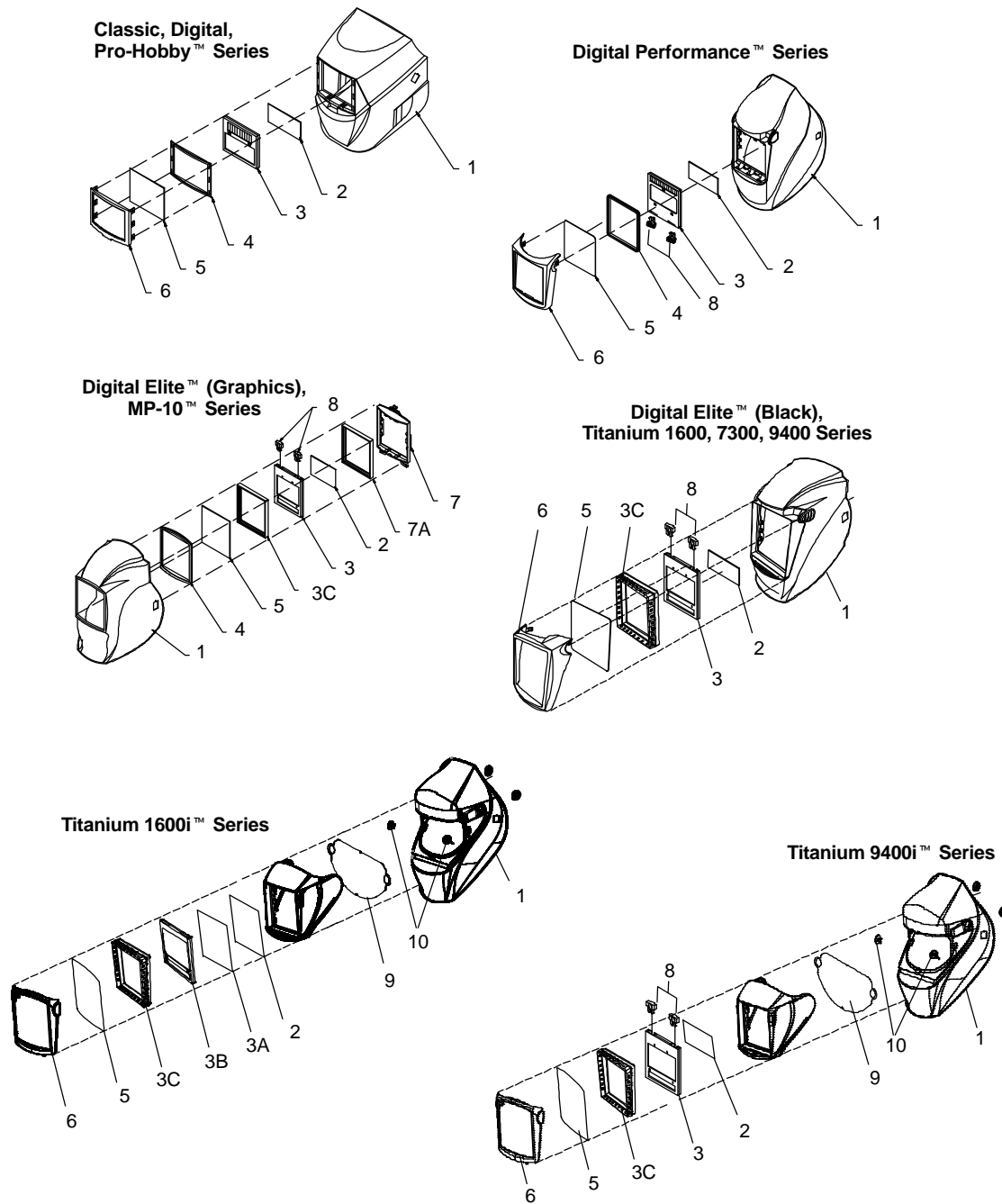

Figure 5-5. Optional Hard Hat Head Assembly Accessories

Figure 5-5. Parts Table For Optional Hard-Hat Head Assembly Accessories

Item	Description	MP-10 Series	Classic Series		Digital Pro-Hobby Series	Digital Performance Series	Digital Elite Series	Titanium 1600	Titanium 1600i	Titanium 7300	Titanium 9400	Titanium 9400i
	Complete Helmet	238497	231703	251292	256166	256159	257213	245799	255519	256175	256176	256177
1	Helmet Shell, Black	216331	231415	231415	231415	232020	241976	--	--	--	--	--
	Helmet Shell, Optional Graphics	See Note 1	--	--	See Note 1	See Note 1	See Note 1	--	--	--	--	--
	Helmet Shell, Titanium	--	--	--	--	--	--	243530	245820	243530	258601	245820
2	Inside Lens Cover (5-1/4 x 4-1/2")	235628	--	--	--	--	--	235628	235628	--	--	--
	Inside Lens Cover (4-1/4 x 1-3/4")	--	231410	231410	231410	--	--	--	--	--	--	--
	Inside Lens Cover (4-1/4 x 2")	--	--	--	--	770237	--	--	--	770237	--	--
	Inside Lens Cover (4-1/4 x 2-1/2")	--	--	--	--	--	216327	--	--	--	216327	216327
3	Auto-Darkening Lens Assembly	--	231571	251293	256467	256468	256469	--	--	256358	256359	256360
3a	Filter Plate, Shade #10	235630	--	--	--	--	--	235630	235630	--	--	--
3b	Aluminum Plate	--	--	--	--	--	--	246759	246759	--	--	--
3c	Gasket, Auto-Darkening Lens Assembly	--	--	--	--	--	241977* 234758**	245813	245813	241977	241977	241977
4	Gasket, Outside Lens Cover	216337	231412	231412	231412	232028	216337	--	--	--	--	--
5	Outside Lens Cover (4-1/2 x 3-3/4")	--	231411	231411	231411	--	--	--	--	--	--	--
	Outside Lens Cover (4-3/8 x 5")	--	--	--	--	231921	--	--	--	--	--	--
	Outside Lens Cover (4-11/16 x 5-5/8")	--	--	--	--	--	216326	216326	216326	216326	216326	216326
6	Outside Lens Holder, Black	241978	231572	231572	231752	232030	241978	--	--	--	--	--
	Outside Lens Holder, Titanium	--	--	--	--	--	--	243396	245815	243396	243396	245815
7	Frame, Lens Holding	216335	--	--	--	--	234758	--	--	--	--	--
7a	Spacer, Lens Holding	235629	--	--	--	--	--	--	--	--	--	--
8	Battery Tray Kit	--	--	--	256729	256730	216339	--	--	216339	216339	216339
	Battery, Lithium CR2450 (not shown)	--	--	AAA	217043	217043	217043	--	--	217043	217043	217043
	Battery Cover (now shown)	--	--	231413	--	--	--	--	--	--	--	--
9	Grinding Shield Lens, Clear	--	--	--	--	--	--	--	245818	--	--	245818
10	Grinding Shield Clips	--	--	--	--	--	--	--	245819	--	--	245819
11	Button, Replacement Grind (not shown)	--	--	--	--	--	--	--	--	256179	256179	--
	Lens, 0.75 Magnification	212235	212235	212235	212235	212235	212235	212235	212235	212235	212235	212235
	Lens, 1.00 Magnification	212236	212236	212236	212236	212236	212236	212236	212236	212236	212236	212236
	Lens, 1.25 Magnification	212237	212237	212237	212237	212237	212237	212237	212237	212237	212237	212237
	Lens, 1.50 Magnification	212238	212238	212238	212238	212238	212238	212238	212238	212238	212238	212238
	Lens, 1.75 Magnification	212239	212239	212239	212239	212239	212239	212239	212239	212239	212239	212239
	Lens, 2.00 Magnification	212240	212240	212240	212240	212240	212240	212240	212240	212240	212240	212240
	Lens, 2.25 Magnification	212241	212241	212241	212241	212241	212241	212241	212241	212241	212241	212241
	Lens, 2.50 Magnification	212242	212242	212242	212242	212242	212242	212242	212242	212242	212242	212242

Note 1: Refer to Helmet Owner's Manual for graphic options

*: Gasket for Black Digital Elite Helmets

** : Gasket for Graphic Digital Elite Helmets

SECTION 6 – WARRANTY

LIMITED WARRANTY – Subject to the terms and conditions below. Miller Electric Mfg. Co., Appleton, Wisconsin, warrants to its original retail purchaser that the new Miller equipment sold after the effective date of this limited warranty is free of defects in material and workmanship at the time it is shipped by Miller. THIS WARRANTY IS EXPRESSLY IN LIEU OF ALL OTHER WARRANTIES, EXPRESS OR IMPLIED, INCLUDING THE WARRANTIES OR MERCHANTABILITY AND FITNESS.

Miller Digital Titanium Series auto-darkening lens helmets are warranted for three years from the date of purchase. The blower assembly is warranted for one year from the date of purchase. The battery is warranted for six months from the date of purchase. *Proof of purchase is required for warranty transactions so it is imperative that a copy of the original invoice or sales receipt be retained.*

For warranty transactions, contact your Miller Distributor.

Effective January 1, 2014



Visit our website at
www.MillerWelds.com



Miller Electric Mfg. Co.
An Illinois Tool Works Company
1635 West Spencer Street
Appleton, WI 54914 USA