



OM-236 949A

2008-02

Processes



Stick (SMAW) Welding



TIG (GTAW) Welding



MIG (GMAW) Welding



Flux Cored (FCAW) Welding



Air Carbon Arc (CAC-A)
Cutting and Gouging

Description



Engine Driven Welding Generator

Big Blue[®] 300 D PRO 300 D

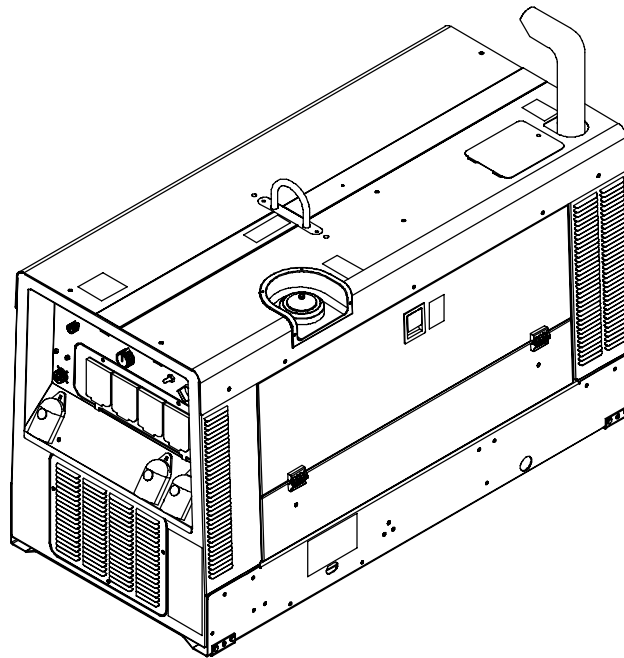

Visit our website at
www.MillerWelds.com

OWNER'S MANUAL

File: Engine Drive



From Miller to You

Thank you and congratulations on choosing Miller. Now you can get the job done and get it done right. We know you don't have time to do it any other way.

That's why when Niels Miller first started building arc welders in 1929, he made sure his products offered long-lasting value and superior quality. Like you, his customers couldn't afford anything less. Miller products had to be more than the best they could be. They had to be the best you could buy.

Today, the people that build and sell Miller products continue the tradition. They're just as committed to providing equipment and service that meets the high standards of quality and value established in 1929.

This Owner's Manual is designed to help you get the most out of your Miller products. Please take time to read the Safety precautions. They will help you protect yourself against potential hazards on the worksite.

We've made installation and operation quick and easy. With Miller you can count on years of reliable service with proper maintenance. And if for some reason the unit needs repair, there's a Troubleshooting section that will help you figure out what the problem is. The parts list will then help you to decide the exact part you may need to fix the problem. Warranty and service information for your particular model are also provided.



Miller is the first welding equipment manufacturer in the U.S.A. to be registered to the ISO 9001:2000 Quality System Standard.

Miller Electric manufactures a full line of welders and welding related equipment. For information on other quality Miller products, contact your local Miller distributor to receive the latest full line catalog or individual specification sheets. **To locate your nearest distributor or service agency call 1-800-4-A-Miller, or visit us at www.MillerWelds.com on the web.**



Working as hard as you do – every power source from Miller is backed by the most hassle-free warranty in the business.



TABLE OF CONTENTS

SECTION 1 – SAFETY PRECAUTIONS – READ BEFORE USING	1
1-1. Symbol Usage	1
1-2. Arc Welding Hazards	1
1-3. Engine Hazards	3
1-4. Compressed Air Hazards	3
1-5. Additional Symbols For Installation, Operation, And Maintenance	4
1-6. California Proposition 65 Warnings	5
1-7. Principal Safety Standards	5
1-8. EMF Information	5
SECTION 2 – CONSIGNES DE SÉCURITÉ – LIRE AVANT UTILISATION	6
2-1. Signification des symboles	6
2-2. Dangers relatifs au soudage à l'arc	6
2-3. Dangers existant en relation avec le moteur	8
2-4. Dangers liés à l'air comprimé	9
2-5. Dangers supplémentaires en relation avec l'installation, le fonctionnement et la maintenance	9
2-6. Proposition californienne 65 Avertissements	11
2-7. Principales normes de sécurité	11
2-8. Information EMF	11
SECTION 3 – DEFINITIONS	12
3-1. Warning Label Definitions	12
3-2. Symbols And Definitions	13
SECTION 4 – SPECIFICATIONS	14
4-1. Weld, Power, And Engine Specifications	14
4-2. Dimensions, Weights, And Operating Angles	14
4-3. Volt-Ampere Curves	15
4-4. Fuel Consumption	16
4-5. Duty Cycle And Overheating	16
4-6. AC Generator Power Curve	17
SECTION 5 – INSTALLATION	18
5-1. Installing Welding Generator	18
5-2. Mounting Welding Generator	19
5-4. Rating Label Location	20
5-5. Installing Exhaust Pipe	21
5-6. Activating The Dry Charge Battery (If Applicable)	22
5-7. Connecting The Battery	22
5-8. Engine Prestart Checks	23
5-9. Connecting To Weld Output Terminals	24
5-10. Selecting Weld Cable Sizes*	25
5-11. Connecting To Remote 14 Receptacle RC14	26
SECTION 6 – OPERATING WELDING GENERATOR	28
6-1. Front Panel Controls (See Section 6-2)	28
6-2. Description Of Front Panel Controls (See Section 6-1)	29
6-3. Process/Contactor Switch	30
6-4. Lift-Arc™ TIG With Auto-Crater™ And Auto-Stop™	31
6-5. Remote Voltage/Amperage Control	32
6-6. Fuel/Hour Gauge Descriptions	33
SECTION 7 – OPERATING AUXILIARY EQUIPMENT	34
7-1. Generator Power Receptacles	34
SECTION 8 – MAINTENANCE & TROUBLESHOOTING	35
8-1. Routine Maintenance	35
8-2. Maintenance Label	36
8-3. Servicing Air Cleaner	37

TABLE OF CONTENTS

8-4. Inspecting And Cleaning Optional Spark Arrestor Muffler	38
8-5. Servicing Engine Cooling System	38
8-6. Servicing Fuel And Lubrication Systems	39
8-7. Overload Protection	40
8-8. Checking Generator Brushes	41
8-9. Adjusting Engine Speed	41
8-10. Voltmeter/Ammeter Help Displays	42
8-11. Troubleshooting	43
SECTION 9 – ELECTRICAL DIAGRAMS	46
SECTION 10 – RUN-IN PROCEDURE	48
10-1. Wetstacking	48
10-2. Run-In Procedure Using Load Bank	49
10-3. Run-In Procedure Using Resistance Grid	50
SECTION 11 – GENERATOR POWER GUIDELINES	51
SECTION 12 – PARTS LIST	58
WARRANTY	

SECTION 1 – SAFETY PRECAUTIONS – READ BEFORE USING

rom_2007-04

 Protect yourself and others from injury — read and follow these precautions.

1-1. Symbol Usage



DANGER! – Indicates a hazardous situation which, if not avoided, will result in death or serious injury. The possible hazards are shown in the adjoining symbols or explained in the text.



Indicates a hazardous situation which, if not avoided, could result in death or serious injury. The possible hazards are shown in the adjoining symbols or explained in the text.

NOTICE – Indicates statements not related to personal injury.

 Indicates special instructions.



This group of symbols means Warning! Watch Out! ELECTRIC SHOCK, MOVING PARTS, and HOT PARTS hazards. Consult symbols and related instructions below for necessary actions to avoid the hazards.

1-2. Arc Welding Hazards



The symbols shown below are used throughout this manual to call attention to and identify possible hazards. When you see the symbol, watch out, and follow the related instructions to avoid the hazard. The safety information given below is only a summary of the more complete safety information found in the Safety Standards listed in Section 1-7. Read and follow all Safety Standards.



Only qualified persons should install, operate, maintain, and repair this unit.



During operation, keep everybody, especially children, away.



ELECTRIC SHOCK can kill.

Touching live electrical parts can cause fatal shocks or severe burns. The electrode and work circuit is electrically live whenever the output is on. The input power circuit and machine internal circuits are also live when power is on. In semiautomatic or automatic wire welding, the wire, wire reel, drive roll housing, and all metal parts touching the welding wire are electrically live. Incorrectly installed or improperly grounded equipment is a hazard.

- Do not touch live electrical parts.
- Wear dry, hole-free insulating gloves and body protection.
- Insulate yourself from work and ground using dry insulating mats or covers big enough to prevent any physical contact with the work or ground.
- Do not use AC output in damp areas, if movement is confined, or if there is a danger of falling.
- Use AC output ONLY if required for the welding process.
- If AC output is required, use remote output control if present on unit.
- Additional safety precautions are required when any of the following electrically hazardous conditions are present: in damp locations or while wearing wet clothing; on metal structures such as floors, gratings, or scaffolds; when in cramped positions such as sitting, kneeling, or lying; or when there is a high risk of unavoidable or accidental contact with the workpiece or ground. For these conditions, use the following equipment in order presented: 1) a semiautomatic DC constant voltage (wire) welder, 2) a DC manual (stick) welder, or 3) an AC welder with reduced open-circuit voltage. In most situations, use of a DC, constant voltage wire welder is recommended. And, do not work alone!
- Disconnect input power or stop engine before installing or servicing this equipment. Lockout/tagout input power according to OSHA 29 CFR 1910.147 (see Safety Standards).
- Properly install and ground this equipment according to its Owner's Manual and national, state, and local codes.

- Always verify the supply ground — check and be sure that input power cord ground wire is properly connected to ground terminal in disconnect box or that cord plug is connected to a properly grounded receptacle outlet.
- When making input connections, attach proper grounding conductor first – double-check connections.
- Keep cords dry, free of oil and grease, and protected from hot metal and sparks.
- Frequently inspect input power cord for damage or bare wiring — replace cord immediately if damaged — bare wiring can kill.
- Turn off all equipment when not in use.
- Do not use worn, damaged, undersized, or poorly spliced cables.
- Do not drape cables over your body.
- If earth grounding of the workpiece is required, ground it directly with a separate cable.
- Do not touch electrode if you are in contact with the work, ground, or another electrode from a different machine.
- Use only well-maintained equipment. Repair or replace damaged parts at once. Maintain unit according to manual.
- Do not touch electrode holders connected to two welding machines at the same time since double open-circuit voltage will be present.
- Wear a safety harness if working above floor level.
- Keep all panels and covers securely in place.
- Clamp work cable with good metal-to-metal contact to workpiece or worktable as near the weld as practical.
- Insulate work clamp when not connected to workpiece to prevent contact with any metal object.
- Do not connect more than one electrode or work cable to any single weld output terminal.

SIGNIFICANT DC VOLTAGE exists in inverters after stopping engine.

- Stop engine on inverter and discharge input capacitors according to instructions in Maintenance Section before touching any parts.

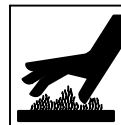

HOT PARTS can cause severe burns.

- Do not touch hot parts bare handed.
- Allow cooling period before working on equipment.
- To handle hot parts, use proper tools and/or wear heavy, insulated welding gloves and clothing to prevent burns.

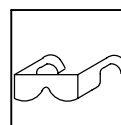

FLYING METAL or DIRT can injure eyes.

- Welding, chipping, wire brushing, and grinding cause sparks and flying metal. As welds cool, they can throw off slag.
- Wear approved safety glasses with side shields even under your welding helmet.



FUMES AND GASES can be hazardous.

Welding produces fumes and gases. Breathing these fumes and gases can be hazardous to your health.

- Keep your head out of the fumes. Do not breathe the fumes.
- If inside, ventilate the area and/or use local forced ventilation at the arc to remove welding fumes and gases.
- If ventilation is poor, wear an approved air-supplied respirator.
- Read and understand the Material Safety Data Sheets (MSDSs) and the manufacturer's instructions for metals, consumables, coatings, cleaners, and degreasers.
- Work in a confined space only if it is well ventilated, or while wearing an air-supplied respirator. Always have a trained watch-person nearby. Welding fumes and gases can displace air and lower the oxygen level causing injury or death. Be sure the breathing air is safe.
- Do not weld in locations near degreasing, cleaning, or spraying operations. The heat and rays of the arc can react with vapors to form highly toxic and irritating gases.
- Do not weld on coated metals, such as galvanized, lead, or cadmium plated steel, unless the coating is removed from the weld area, the area is well ventilated, and while wearing an air-supplied respirator. The coatings and any metals containing these elements can give off toxic fumes if welded.



BUILDUP OF GAS can injure or kill.

- Shut off shielding gas supply when not in use.
- Always ventilate confined spaces or use approved air-supplied respirator.



ARC RAYS can burn eyes and skin.

Arc rays from the welding process produce intense visible and invisible (ultraviolet and infrared) rays that can burn eyes and skin. Sparks fly off from the weld.

- Wear an approved welding helmet fitted with a proper shade of filter lenses to protect your face and eyes from arc rays and sparks when welding or watching (see ANSI Z49.1 and Z87.1 listed in Safety Standards).
- Wear approved safety glasses with side shields under your helmet.
- Use protective screens or barriers to protect others from flash, glare, and sparks; warn others not to watch the arc.
- Wear protective clothing made from durable, flame-resistant material (leather, heavy cotton, or wool) and foot protection.



WELDING can cause fire or explosion.

Welding on closed containers, such as tanks, drums, or pipes, can cause them to blow up. Sparks can fly off from the welding arc. The flying sparks, hot workpiece, and hot equipment can cause fires and burns. Accidental contact of electrode to metal objects can cause sparks, explosion, overheating, or fire. Check and be sure the area is safe before doing any welding.

- Remove all flammables within 35 ft (10.7 m) of the welding arc. If this is not possible, tightly cover them with approved covers.
- Do not weld where flying sparks can strike flammable material.
- Protect yourself and others from flying sparks and hot metal.
- Be alert that welding sparks and hot materials from welding can easily go through small cracks and openings to adjacent areas.
- Watch for fire, and keep a fire extinguisher nearby.
- Be aware that welding on a ceiling, floor, bulkhead, or partition can cause fire on the hidden side.

- Do not weld on closed containers such as tanks, drums, or pipes, unless they are properly prepared according to AWS F4.1 (see Safety Standards).
- Do not weld where the atmosphere may contain flammable dust, gas, or liquid vapors (such as gasoline).
- Connect work cable to the work as close to the welding area as practical to prevent welding current from traveling long, possibly unknown paths and causing electric shock, sparks, and fire hazards.
- Do not use welder to thaw frozen pipes.
- Remove stick electrode from holder or cut off welding wire at contact tip when not in use.
- Wear oil-free protective garments such as leather gloves, heavy shirt, cuffless trousers, high shoes, and a cap.
- Remove any combustibles, such as a butane lighter or matches, from your person before doing any welding.
- After completion of work, inspect area to ensure it is free of sparks, glowing embers, and flames.
- Use only correct fuses or circuit breakers. Do not oversize or bypass them.
- Follow requirements in OSHA 1910.252 (a) (2) (iv) and NFPA 51B for hot work and have a fire watcher and extinguisher nearby.



NOISE can damage hearing.

Noise from some processes or equipment can damage hearing.

- Wear approved ear protection if noise level is high.



MAGNETIC FIELDS can affect Implanted Medical Devices.

- Wearers of Pacemakers and other Implanted Medical Devices should keep away.
- Implanted Medical Device wearers should consult their doctor and the device manufacturer before going near arc welding, spot welding, gouging, plasma arc cutting, or induction heating operations.

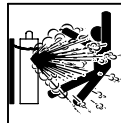

CYLINDERS can explode if damaged.

Shielding gas cylinders contain gas under high pressure. If damaged, a cylinder can explode. Since gas cylinders are normally part of the welding process, be sure to treat them carefully.

- Protect compressed gas cylinders from excessive heat, mechanical shocks, physical damage, slag, open flames, sparks, and arcs.
- Install cylinders in an upright position by securing to a stationary support or cylinder rack to prevent falling or tipping.
- Keep cylinders away from any welding or other electrical circuits.
- Never drape a welding torch over a gas cylinder.
- Never allow a welding electrode to touch any cylinder.
- Never weld on a pressurized cylinder — explosion will result.
- Use only correct shielding gas cylinders, regulators, hoses, and fittings designed for the specific application; maintain them and associated parts in good condition.
- Turn face away from valve outlet when opening cylinder valve.
- Keep protective cap in place over valve except when cylinder is in use or connected for use.
- Use the right equipment, correct procedures, and sufficient number of persons to lift and move cylinders.
- Read and follow instructions on compressed gas cylinders, associated equipment, and Compressed Gas Association (CGA) publication P-1 listed in Safety Standards.

1-3. Engine Hazards



BATTERY EXPLOSION can BLIND.

- Always wear a face shield, rubber gloves, and protective clothing when working on a battery.
- Stop engine before disconnecting or connecting battery cables or servicing battery.
- Do not allow tools to cause sparks when working on a battery.
- Do not use welder to charge batteries or jump start vehicles.
- Observe correct polarity (+ and -) on batteries.
- Disconnect negative (-) cable first and connect it last.



FUEL can cause fire or explosion.

- Stop engine and let it cool off before checking or adding fuel.
- Do not add fuel while smoking or if unit is near any sparks or open flames.
- Do not overfill tank — allow room for fuel to expand.
- Do not spill fuel. If fuel is spilled, clean up before starting engine.
- Dispose of rags in a fireproof container.
- Always keep nozzle in contact with tank when fueling.



MOVING PARTS can cause injury.

- Keep away from fans, belts, and rotors.
- Keep all doors, panels, covers, and guards closed and securely in place.
- Stop engine before installing or connecting unit.
- Have only qualified people remove doors, panels, covers, or guards for maintenance and troubleshooting as necessary.
- To prevent accidental starting during servicing, disconnect negative (-) battery cable from battery.
- Keep hands, hair, loose clothing, and tools away from moving parts.
- Reinstall doors, panels, covers, or guards when servicing is finished and before starting engine.
- Before working on generator, remove spark plugs or injectors to keep engine from kicking back or starting.
- Block flywheel so that it will not turn while working on generator components.



HOT PARTS can cause severe burns.

- Do not touch hot parts bare handed.
- Allow cooling period before working on equipment.
- To handle hot parts, use proper tools and/or wear heavy, insulated welding gloves and clothing to prevent burns.

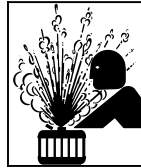

STEAM AND HOT COOLANT can burn.

- If possible, check coolant level when engine is cold to avoid scalding.
- Always check coolant level at overflow tank, if present on unit, instead of radiator (unless told otherwise in maintenance section or engine manual).
- If the engine is warm, checking is needed, and there is no overflow tank, follow the next two statements.
- Wear safety glasses and gloves and put a rag over radiator cap.
- Turn cap slightly and let pressure escape slowly before completely removing cap.

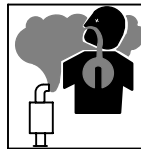

Using a generator indoors CAN KILL YOU IN MINUTES.

- Generator exhaust contains carbon monoxide. This is a poison you cannot see or smell.
- NEVER use inside a home or garage, EVEN IF doors and windows are open.
- Only use OUTSIDE and far away from windows, doors, and vents.

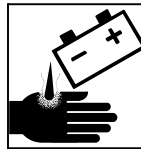

BATTERY ACID can BURN SKIN and EYES.

- Do not tip battery.
- Replace damaged battery.
- Flush eyes and skin immediately with water.



ENGINE HEAT can cause fire.

- Do not locate unit on, over, or near combustible surfaces or flammables.
- Keep exhaust and exhaust pipes way from flammables.



EXHAUST SPARKS can cause fire.

- Do not let engine exhaust sparks cause fire.
- Use approved engine exhaust spark arrestor in required areas — see applicable codes.

1-4. Compressed Air Hazards



BREATHING COMPRESSED AIR can cause serious injury or death.

- Do not use compressed air for breathing.
- Use only for cutting, gouging, and tools.

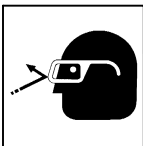

COMPRESSED AIR can cause injury.

- Wear approved safety goggles.
- Do not direct air stream toward self or others.

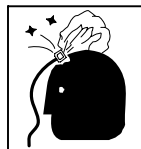

TRAPPED AIR PRESSURE AND WHIPPING HOSES can cause injury.

- Release air pressure from tools and system before servicing, adding or changing attachments, or opening compressor oil drain or oil fill cap.



HOT METAL from air arc cutting and gouging can cause fire or explosion.

- Do not cut or gouge near flammables.
- Watch for fire; keep extinguisher nearby.



HOT PARTS can cause burns and injury.

- Do not touch hot compressor or air system parts.
- Let system cool down before touching or servicing.

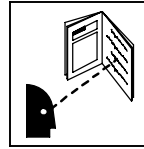

READ INSTRUCTIONS.

- Read Owner's Manual before using or servicing unit.
- Stop engine and release air pressure before servicing.
- Use only genuine replacement parts from the manufacturer.

1-5. Additional Symbols For Installation, Operation, And Maintenance



FIRE OR EXPLOSION hazard.

- Do not install or place unit on, over, or near combustible surfaces.
- Do not install unit near flammables.
- Do not overload building wiring – be sure power supply system is properly sized, rated, and protected to handle this unit.

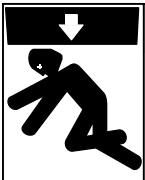

FALLING UNIT can cause injury.

- Use lifting eye to lift unit and properly installed accessories only, NOT gas cylinders. Do not exceed maximum lift eye weight rating (see Specifications).
- Lift and support unit only with proper equipment and correct procedures.
- If using lift forks to move unit, be sure forks are long enough to extend beyond opposite side of unit.

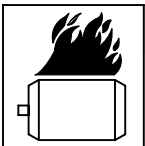

OVERHEATING can damage motors.

- Turn off or unplug equipment before starting or stopping engine.
- Do not let low voltage and frequency caused by low engine speed damage electric motors.
- Do not connect 50 or 60 Hertz motors to the 100 Hertz receptacle where applicable.

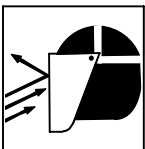

FLYING SPARKS can cause injury.

- Wear a face shield to protect eyes and face.
- Shape tungsten electrode only on grinder with proper guards in a safe location wearing proper face, hand, and body protection.
- Sparks can cause fires — keep flammables away.



MOVING PARTS can cause injury.

- Keep away from moving parts.
- Keep away from pinch points such as drive rolls.

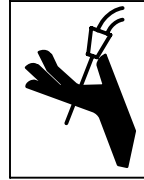

WELDING WIRE can cause injury.

- Do not press gun trigger until instructed to do so.
- Do not point gun toward any part of the body, other people, or any metal when threading welding wire.

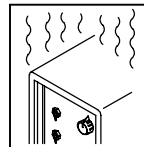

OVERUSE can cause OVERHEATING.

- Allow cooling period; follow rated duty cycle.
- Reduce current or reduce duty cycle before starting to weld again.
- Do not block or filter airflow to unit.

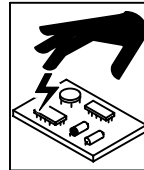

STATIC (ESD) can damage PC boards.

- Put on grounded wrist strap BEFORE handling boards or parts.
- Use proper static-proof bags and boxes to store, move, or ship PC boards.

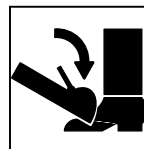

TILTING OF TRAILER can cause injury.

- Use tongue jack or blocks to support weight.
- Properly install welding generator onto trailer according to instructions supplied with trailer.

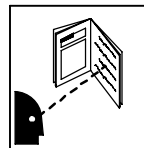

READ INSTRUCTIONS.

- Read Owner's Manual before using or servicing unit.
- Use only genuine replacement parts from the manufacturer.
- Perform engine and air compressor maintenance and service according to this manual and the engine/air compressor (if applicable) manuals.

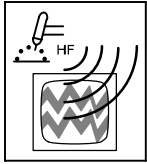

H.F. RADIATION can cause interference.

- High-frequency (H.F.) can interfere with radio navigation, safety services, computers, and communications equipment.
- Have only qualified persons familiar with electronic equipment perform this installation.
- The user is responsible for having a qualified electrician promptly correct any interference problem resulting from the installation.
- If notified by the FCC about interference, stop using the equipment at once.
- Have the installation regularly checked and maintained.
- Keep high-frequency source doors and panels tightly shut, keep spark gaps at correct setting, and use grounding and shielding to minimize the possibility of interference.

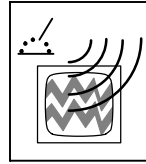

ARC WELDING can cause interference.

- Electromagnetic energy can interfere with sensitive electronic equipment such as micro-processors, computers, and computer-driven equipment such as robots.
- Be sure all equipment in the welding area is electromagnetically compatible.
- To reduce possible interference, keep weld cables as short as possible, close together, and down low, such as on the floor.
- Locate welding operation 100 meters from any sensitive electronic equipment.
- Be sure this welding machine is installed and grounded according to this manual.
- If interference still occurs, the user must take extra measures such as moving the welding machine, using shielded cables, using line filters, or shielding the work area.

1-6. California Proposition 65 Warnings

- ⚠ Welding or cutting equipment produces fumes or gases which contain chemicals known to the State of California to cause birth defects and, in some cases, cancer. (California Health & Safety Code Section 25249.5 et seq.)**
- ⚠ Battery posts, terminals and related accessories contain lead and lead compounds, chemicals known to the State of California to cause cancer and birth defects or other reproductive harm. Wash hands after handling.**

For Gasoline Engines:

- ⚠ Engine exhaust contains chemicals known to the State of California to cause cancer, birth defects, or other reproductive harm.**

For Diesel Engines:

- ⚠ Diesel engine exhaust and some of its constituents are known to the State of California to cause cancer, birth defects, and other reproductive harm.**

1-7. Principal Safety Standards

Safety in Welding, Cutting, and Allied Processes, ANSI Standard Z49.1, from Global Engineering Documents (phone: 1-877-413-5184, website: www.global.ihs.com).

Recommended Safe Practices for the Preparation for Welding and Cutting of Containers and Piping, American Welding Society Standard AWS F4.1, from Global Engineering Documents (phone: 1-877-413-5184, website: www.global.ihs.com).

National Electrical Code, NFPA Standard 70, from National Fire Protection Association, P.O. Box 9101, Quincy, MA 02269-9101 (phone: 617-770-3000, website: www.nfpa.org and www.sparky.org).

Safe Handling of Compressed Gases in Cylinders, CGA Pamphlet P-1, from Compressed Gas Association, 4221 Walney Road, 5th Floor, Chantilly, VA 20151 (phone: 703-788-2700, website: www.cganet.com).

Code for Safety in Welding and Cutting, CSA Standard W117.2, from Canadian Standards Association, Standards Sales, 5060 Mississauga,

Ontario, Canada L4W 5NS (phone: 800-463-6727 or in Toronto 416-747-4044, website: www.csa-international.org).

Safe Practice For Occupational And Educational Eye And Face Protection, ANSI Standard Z87.1, from American National Standards Institute, 25 West 43rd Street, New York, NY 10036-8002 (phone: 212-642-4900, website: www.ansi.org).

Standard for Fire Prevention During Welding, Cutting, and Other Hot Work, NFPA Standard 51B, from National Fire Protection Association, P.O. Box 9101, Quincy, MA 02269-9101 (phone: 617-770-3000, website: www.nfpa.org).

OSHA, Occupational Safety and Health Standards for General Industry, Title 29, Code of Federal Regulations (CFR), Part 1910, Subpart Q, and Part 1926, Subpart J, from U.S. Government Printing Office, Superintendent of Documents, P.O. Box 371954, Pittsburgh, PA 15250-7954 (phone: 1-866-512-1800) (there are 10 Regional Offices—phone for Region 5, Chicago, is 312-353-2220, website: www.osha.gov).

1-8. EMF Information

Considerations About Welding And The Effects Of Low Frequency Electric And Magnetic Fields

Welding current, as it flows through welding cables, will cause electromagnetic fields. There has been and still is some concern about such fields. However, after examining more than 500 studies spanning 17 years of research, a special blue ribbon committee of the National Research Council concluded that: "The body of evidence, in the committee's judgment, has not demonstrated that exposure to power-frequency electric and magnetic fields is a human-health hazard." However, studies are still going forth and evidence continues to be examined. Until the final conclusions of the research are reached, you may wish to minimize your exposure to electromagnetic fields when welding or cutting.

To reduce magnetic fields in the workplace, use the following procedures:

1. Keep cables close together by twisting or taping them, or using a cable cover.
2. Arrange cables to one side and away from the operator.
3. Do not coil or drape cables around your body.
4. Keep welding power source and cables as far away from operator as practical.
5. Connect work clamp to workpiece as close to the weld as possible.

About Implanted Medical Devices:

Implanted Medical Device wearers should consult their doctor and the device manufacturer before performing or going near arc welding, spot welding, gouging, plasma arc cutting, or induction heating operations. If cleared by your doctor, then following the above procedures is recommended.

SECTION 2 – CONSIGNES DE SÉCURITÉ – LIRE AVANT UTILISATION

rom_2007-04fre

! Se protéger, ainsi que toute autre personne travaillant sur les lieux, contre les étincelles et le métal chaud.

2-1. Signification des symboles



DANGER! – Indique une situation dangereuse qui si on l'évite pas peut donner la mort ou des blessures graves. Les dangers possibles sont montrés par les symboles joints ou sont expliqués dans le texte.



Indique une situation dangereuse qui si on l'évite pas peut donner la mort ou des blessures graves. Les dangers possibles sont montrés par les symboles joints ou sont expliqués dans le texte.

NOTE – Indique des déclarations pas en relation avec des blessures personnelles.

Indique des instructions spécifiques.



Ce groupe de symboles veut dire Avertissement! Attention! DANGER DE CHOC ELECTRIQUE, PIECES EN MOUVEMENT, et PIECES CHAUDES. Consulter les symboles et les instructions ci-dessous y afférant pour les actions nécessaires afin d'éviter le danger.

2-2. Dangers relatifs au soudage à l'arc



Les symboles présentés ci-après sont utilisés tout au long du présent manuel pour attirer votre attention et identifier les risques de danger. Lorsque vous voyez un symbole, soyez vigilant et suivez les directives mentionnées afin d'éviter tout danger. Les consignes de sécurité présentées ci-après ne font que résumer l'information contenue dans les normes de sécurité énumérées à la section 2-7. Veuillez lire et respecter toutes ces normes de sécurité.



L'installation, l'utilisation, l'entretien et les réparations ne doivent être confiés qu'à des personnes qualifiées.



Au cours de l'utilisation, tenir toute personne à l'écart et plus particulièrement les enfants.



UN CHOC ÉLECTRIQUE peut tuer.

Un simple contact avec des pièces électriques peut provoquer une électrocution ou des blessures graves. L'électrode et le circuit de soudage sont sous tension

dès que l'appareil est sur ON. Le circuit d'entrée et les circuits internes de l'appareil sont également sous tension à ce moment-là. En soudage semi-automatique ou automatique, le fil, le dévidoir, le logement des galets d'entraînement et les pièces métalliques en contact avec le fil de soudage sont sous tension. Des matériels mal installés ou mal mis à la terre présentent un danger.

- Ne jamais toucher les pièces électriques sous tension.
- Porter des gants et des vêtements de protection secs ne comportant pas de trous.
- S'isoler de la pièce et de la terre au moyen de tapis ou d'autres moyens isolants suffisamment grands pour empêcher le contact physique éventuel avec la pièce ou la terre.
- Ne pas se servir de source électrique à courant électrique dans les zones humides, dans les endroits confinés ou là où on risque de tomber.
- Se servir d'une source électrique à courant électrique UNIQUEMENT si le procédé de soudage le demande.
- Si l'utilisation d'une source électrique à courant électrique s'avère nécessaire, se servir de la fonction de télécommande si l'appareil en est équipé.
- Des précautions de sécurité supplémentaires sont requises dans des environnements à risque comme: les endroits humides ou lorsque l'on porte des vêtements mouillés; sur des structures métalliques au sol, grillages et échafaudages; dans des positions assises, à genoux et allongées; ou quand il y a un risque important de contact accidentel avec la pièce ou le sol. Dans ces cas utiliser les appareils suivants dans l'ordre de préférence: 1) un poste à souder DC semi-automatique de type CV (MIG/MAG), 2) un poste à souder manuel (électrode enrobée) DC, 3) un poste à souder

manuel AC avec tension à vide réduite. Dans la plupart des cas, un poste courant continu de type CV est recommandé. Et, ne pas travailler seul!

- Couper l'alimentation ou arrêter le moteur avant de procéder à l'installation, à la réparation ou à l'entretien de l'appareil. Déverrouiller l'alimentation selon la norme OSHA 29 CFR 1910.147 (voir normes de sécurité).
- Installer et mettre à la terre correctement cet appareil conformément à son manuel d'utilisation et aux codes nationaux, provinciaux et municipaux.
- Toujours vérifier la terre du cordon d'alimentation – Vérifier et s'assurer que le fil de terre du cordon d'alimentation est bien raccordé à la borne de terre du sectionneur ou que la fiche du cordon est raccordée à une prise correctement mise à la terre.
- En effectuant les raccordements d'entrée fixer d'abord le conducteur de mise à la terre approprié et contre-vérifier les connexions.
- Les câbles doivent être exempts d'humidité, d'huile et de graisse; protégez-les contre les étincelles et les pièces métalliques chaudes.
- Vérifier fréquemment le cordon d'alimentation pour voir s'il n'est pas endommagé ou dénudé – remplacer le cordon immédiatement s'il est endommagé – un câble dénudé peut provoquer une électrocution.
- Mettre l'appareil hors tension quand on ne l'utilise pas.
- Ne pas utiliser des câbles usés, endommagés, de grosseur insuffisante ou mal épissés.
- Ne pas enrouler les câbles autour du corps.
- Si la pièce soudée doit être mise à la terre, le faire directement avec un câble distinct – ne pas utiliser le connecteur de pièce ou le câble de retour.
- Ne pas toucher l'électrode quand on est en contact avec la pièce, la terre ou une électrode provenant d'une autre machine.
- Ne pas toucher des porte électrodes connectés à deux machines en même temps à cause de la présence d'une tension à vide doublée.
- N'utiliser qu'un matériel en bon état. Réparer ou remplacer sur-le-champ les pièces endommagées. Entretenir l'appareil conformément à ce manuel.
- Porter un harnais de sécurité quand on travaille en hauteur.
- Maintenir solidement en place tous les panneaux et capots.
- Fixer le câble de retour de façon à obtenir un bon contact métallique avec la pièce à souder ou la table de travail, le plus près possible de la soudure.
- Isoler la pince de masse quand pas mis à la pièce pour éviter le contact avec tout objet métallique.

Une tension DC importante subsiste à l'intérieur des onduleurs après avoir coupé l'alimentation.

- Couper l'alimentation du poste et décharger les condensateurs d'entrée comme indiqué dans la Section Maintenance avant de toucher des composants.



DES PIÈCES CHAUDES peuvent provoquer des brûlures graves.

- Ne pas toucher à mains nues les parties chaudes.
- Prévoir une période de refroidissement avant de travailler à l'équipement.
- Ne pas toucher aux pièces chaudes, utiliser les outils recommandés et porter des gants de soudage et des vêtements épais pour éviter les brûlures.

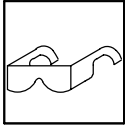

DES PIÈCES DE METAL ou DES SALETES peuvent provoquer des blessures dans les yeux.

- Le soudage, l'écaillage, le passage de la pièce à la brosse en fil de fer, et le meulage génèrent des étincelles et des particules métalliques volantes. Pendant la période de refroidissement des soudures, elles risquent de projeter du laitier.
- Porter des lunettes de sécurité avec écrans latéraux ou un écran facial.



LES FUMÉES ET LES GAZ peuvent être dangereux.

Le soudage génère des fumées et des gaz. Leur inhalation peut être dangereux pour votre santé.

- Eloigner votre tête des fumées. Ne pas respirer les fumées.
- À l'intérieur, ventiler la zone et/ou utiliser une ventilation forcée au niveau de l'arc pour l'évacuation des fumées et des gaz de soudage.
- Si la ventilation est médiocre, porter un respirateur anti-vapeurs approuvé.
- Lire et comprendre les spécifications de sécurité des matériaux (MSDS) et les instructions du fabricant concernant les métaux, les consommables, les revêtements, les nettoyants et les dégraissateurs.
- Travailler dans un espace fermé seulement s'il est bien ventilé ou en portant un respirateur à alimentation d'air. Demander toujours à un surveillant dûment formé de se tenir à proximité. Des fumées et des gaz de soudage peuvent déplacer l'air et abaisser le niveau d'oxygène provoquant des blessures ou des accidents mortels. S'assurer que l'air de respiration ne présente aucun danger.
- Ne pas souder dans des endroits situés à proximité d'opérations de dégraissage, de nettoyage ou de pulvérisation. La chaleur et les rayons de l'arc peuvent réagir en présence de vapeurs et former des gaz hautement toxiques et irritants.
- Ne pas souder des métaux munis d'un revêtement, tels que l'acier galvanisé, plaqué en plomb ou au cadmium à moins que le revêtement n'ait été enlevé dans la zone de soudure, que l'endroit soit bien ventilé, et en portant un respirateur à alimentation d'air. Les revêtements et tous les métaux renfermant ces éléments peuvent dégager des fumées toxiques en cas de soudage.



LES ACCUMULATIONS DE GAZ risquent de provoquer des blessures ou même la mort.

- Fermer l'alimentation du gaz protecteur en cas de non utilisation.
- Veiller toujours à bien aérer les espaces confinés ou se servir d'un respirateur d'adduction d'air homologué.

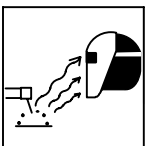

LES RAYONS DE L'ARC peuvent provoquer des brûlures dans les yeux et sur la peau.

Le rayonnement de l'arc du procédé de soudage génère des rayons visibles et invisibles intense (ultraviolets et infrarouges) susceptibles de provoquer des brûlures dans les yeux et sur la peau. Des étincelles sont projetées pendant le soudage.

- Porter un casque de soudage approuvé muni de verres filtrants appropriés pour protéger visage et yeux pendant le soudage (voir ANSI Z49.1 et Z87.1 énuméré dans les normes de sécurité).
- Porter des lunettes de sécurité avec écrans latéraux même sous votre casque.
- Avoir recours à des écrans protecteurs ou à des rideaux pour protéger les autres contre les rayonnements les éblouissements et les étincelles ; prévenir toute personne sur les lieux de ne pas regarder l'arc.
- Porter des vêtements confectionnés avec des matières résistantes et ignifuges (cuir, coton lourd ou laine) et des bottes de protection.

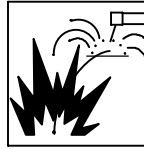

LE SOUDAGE peut provoquer un incendie ou une explosion.

Le soudage effectué sur des conteneurs fermés tel que des réservoirs, tambours ou des conduites peut provoquer leur éclatement. Des étincelles peuvent être projetées de l'arc de soudure. La projection d'étincelles, des pièces chaudes et des équipements chauds peut provoquer des incendies et des brûlures. Le contact accidentel de l'électrode avec des objets métalliques peut provoquer des étincelles, une explosion, un surchauffement ou un incendie. Avant de commencer le soudage, vérifier et s'assurer que l'endroit ne présente pas de danger.

- Déplacer toutes les substances inflammables à une distance de 10,7 m de l'arc de soudage. En cas d'impossibilité les recouvrir soigneusement avec des protections homologués.
- Ne pas souder dans un endroit où des étincelles peuvent tomber sur des substances inflammables.
- Se protéger et d'autres personnes de la projection d'étincelles et de métal chaud.
- Des étincelles et des matériaux chauds du soudage peuvent facilement passer dans d'autres zones en traversant de petites fissures et des ouvertures.
- Surveiller tout déclenchement d'incendie et tenir un extincteur à proximité.
- Le soudage effectué sur un plafond, plancher, paroi ou séparation peut déclencher un incendie de l'autre côté.
- Ne pas effectuer le soudage sur des conteneurs fermés tels que des réservoirs, tambours, ou conduites, à moins qu'ils n'aient été préparés correctement conformément à AWS F4.1 (voir les normes de sécurité).
- Ne soudez pas si l'air ambiant est chargé de particules, gaz, ou vapeurs inflammables (vapeur d'essence, par exemple).
- Brancher le câble de masse sur la pièce la plus près possible de la zone de soudage pour éviter le transport du courant sur une longue distance par des chemins inconnus éventuels en provoquant des risques d'électrocution, d'étincelles et d'incendie.
- Ne pas utiliser le poste de soudage pour dégeler des conduites gelées.
- En cas de non utilisation, enlever la baguette d'électrode du porte-électrode ou couper le fil à la pointe de contact.
- Porter des vêtements de protection dépourvus d'huile tels que des gants en cuir, une chemise en matériau lourd, des pantalons sans revers, des chaussures hautes et un couvre chef.
- Avant de souder, retirer toute substance combustible de vos poches telles qu'un allumeur au butane ou des allumettes.
- Une fois le travail achevé, assurez-vous qu'il ne reste aucune trace d'étincelles incandescentes ni de flammes.
- Utiliser exclusivement des fusibles ou coupe-circuits appropriés. Ne pas augmenter leur puissance; ne pas les ponter.
- Suivre les recommandations dans OSHA 1910.252(a)(2)(iv) et NFPA 51B pour les travaux à chaud et avoir de la surveillance et un extincteur à proximité.

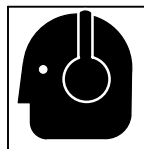

LE BRUIT peut affecter l'ouïe.

Le bruit des processus et des équipements peut affecter l'ouïe.

- Porter des protections approuvées pour les oreilles si le niveau sonore est trop élevé.



LES CHAMPS MAGNETIQUES peuvent affecter des implants médicaux.

- Porteur de simulateur cardiaque ou autre implants médicaux, rester à distance.
- Les porteurs d'implants doivent d'abord consulter leur médecin avant de s'approcher des opérations de soudage à l'arc, de soudage par points, de gougeage, du coupage plasma ou de chauffage par induction.

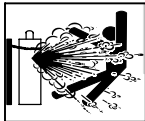

Si des BOUTEILLES sont endommagées, elles pourront exploser.

Des bouteilles de gaz protecteur contiennent du gaz sous haute pression. Si une bouteille est endommagée, elle peut exploser. Du fait que les bouteilles de gaz font normalement partie du procédé de soudage, les manipuler avec précaution.

- Protéger les bouteilles de gaz comprimé d'une chaleur excessive, des chocs mécaniques, des dommages physiques, du laitier, des flammes ouvertes, des étincelles et des arcs.

- Placer les bouteilles debout en les fixant dans un support stationnaire ou dans un porte-bouteilles pour les empêcher de tomber ou de se renverser.
- Tenir les bouteilles éloignées des circuits de soudage ou autres circuits électriques.
- Ne jamais placer une torche de soudage sur une bouteille à gaz.
- Une électrode de soudage ne doit jamais entrer en contact avec une bouteille.
- Ne jamais souder une bouteille pressurisée – risque d'explosion.
- Utiliser seulement des bouteilles de gaz protecteur, régulateurs, tuyaux et raccords convenables pour cette application spécifique; les maintenir ainsi que les éléments associés en bon état.
- Ne pas tenir la tête en face de la sortie en ouvrant la soupape de la bouteille.
- Maintenir le chapeau de protection sur la soupape, sauf en cas d'utilisation ou de branchement de la bouteille.
- Utiliser les équipements corrects, les bonnes procédures et suffisamment de personnes pour soulever et déplacer les bouteilles.
- Lire et suivre les instructions sur les bouteilles de gaz comprimé, l'équipement connexe et le dépliant P-1 de la CGA (Compressed Gas Association) mentionné dans les principales normes de sécurité.

2-3. Dangers existant en relation avec le moteur

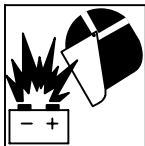

L'EXPLOSION DE LA BATTERIE peut RENDRE AVEUGLE.

- Toujours porter une protection faciale, des gants en caoutchouc et vêtements de protection lors d'une intervention sur la batterie.
- Arrêter le moteur avant de débrancher ou de brancher les câbles de batterie.
- Eviter de provoquer des étincelles avec les outils en travaillant sur la batterie.
- Ne pas utiliser le poste de soudage pour charger les batteries ou des véhicules de démarrage rapide.
- Observer la polarité correcte (+ et -) sur les batteries.
- Débrancher le câble négatif (-) en premier lieu. Le rebrancher en dernier lieu.

- Seules des personnes qualifiées sont autorisées à enlever les portes, panneaux, recouvrements ou dispositifs de protection pour effectuer, s'il y a lieu, des travaux d'entretien et de dépannage.
- Pour empêcher tout démarrage accidentel pendant les travaux d'entretien, débrancher le câble négatif (-) de batterie de la borne.
- Ne pas approcher les mains, cheveux, vêtements lâches et outils des organes mobiles.
- Remettre en place les panneaux ou les dispositifs de protection et fermer les portes à la fin des travaux d'entretien et avant de faire démarrer le moteur.
- Avant d'intervenir, déposer les bougies ou injecteurs pour éviter la mise en route accidentelle du moteur.
- Bloquer le volant moteur pour éviter sa rotation lors d'une intervention sur le générateur.



LE CARBURANT MOTEUR peut provoquer un incendie ou une explosion.

- Arrêter le moteur avant de vérifier le niveau de carburant ou de faire le plein.
- Ne pas faire le plein en fumant ou proche d'une source d'étincelles ou d'une flamme nue.
- Ne pas faire le plein de carburant à ras bord; prévoir de l'espace pour son expansion.
- Faire attention de ne pas renverser de carburant. Nettoyer tout carburant renversé avant de faire démarrer le moteur.
- Jeter les chiffons dans un récipient ignifuge.
- Toujours garder le pistolet en contact avec le réservoir lors du remplissage.



DES PIÈCES CHAUDES peuvent provoquer des brûlures graves.

- Ne pas toucher à mains nues les parties chaudes.
- Prévoir une période de refroidissement avant de travailler à l'équipement.
- Ne pas toucher aux pièces chaudes, utiliser les outils recommandés et porter des gants de soudage et des vêtements épais pour éviter les brûlures.

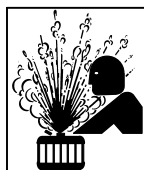

LA VAPEUR ET LE LIQUIDE DE REFROIDISSEMENT CHAUD peuvent provoquer des brûlures.

- Il est préférable de vérifier le liquide de refroidissement une fois le moteur refroidi pour éviter de se brûler.
- Toujours vérifier le niveau de liquide de refroidissement dans le vase d'expansion (si présent), et non dans le radiateur (sauf si précisé autrement dans la section maintenance du manuel du moteur).
- Si le moteur est chaud et que le liquide doit être vérifié, opérer comme suivant.
- Mettre des lunettes de sécurité et des gants, placer un torchon sur le bouchon du radiateur.
- Dévisser le bouchon légèrement et laisser la vapeur s'échapper avant d'enlever le bouchon.



DES ORGANES MOBILES peuvent provoquer des blessures.

- Ne pas approcher les mains des ventilateurs, courroies et autres pièces en mouvement.
- Maintenir fermés et fixement en place les portes, panneaux, recouvrements et dispositifs de protection.
- Arrêter le moteur avant d'installer ou brancher l'appareil.



L'utilisation d'un groupe autonome à l'intérieur PEUT VOUS TUER EN QUELQUES MINUTES.

- Les fumées d'un groupe autonome contient du monoxyde de carbone. C'est un poison invisible et inodore.
- JAMAIS utiliser dans une maison ou garage, même avec les portes et fenêtres ouvertes.
- Uniquement utiliser à l'EXTERIEUR, loin des portes, fenêtres et bouches aération.



L'ACIDE DE LA BATTERIE peut provoquer des brûlures dans les YEUX et sur la PEAU.

- Ne pas renverser la batterie.
- Remplacer une batterie endommagée.
- Rincer immédiatement les yeux et la peau à l'eau.



LA CHALEUR DU MOTEUR peut provoquer un incendie.

- Ne pas placer l'appareil sur, au-dessus ou à proximité de surfaces inflammables.
- Tenir à distance les produits inflammables de l'échappement.



LES ÉTINCELLES À L'ÉCHAPPEMENT peuvent provoquer un incendie.

- Empêcher les étincelles d'échappement du moteur de provoquer un incendie.
- Utiliser uniquement un pare-étincelles approuvé – voir codes en vigueur.

2-4. Dangers liés à l'air comprimé



RESPIRER L'AIR COMPRIMÉ peut provoquer des blessures graves ou causer la mort.

- Ne pas utiliser l'air comprimé pour respirer.
- Utiliser l'air comprimé seulement pour le coupage, gougeage et les outils pneumatiques.

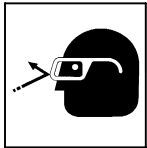

L'AIR COMPRIMÉ peut provoquer des blessures.

- Porter des lunettes de sécurité approuvées.
- Ne pas diriger le jet d'air vers d'autres ou soi-même.

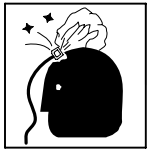

L'AIR COMPRI ME EMMAGASINE ET DES TUYAUX SOUS PRESS ION peuvent provoquer des blessures.

- Relâcher la pression d'air de l'outillage ou du système avant d'effectuer la maintenance, avant de changer ou de rajouter des éléments ou avant d'ouvrir la purge ou le bouchon de remplissage d'huile.



Le METAL CHAUD lors du coupage et gougeage plasma peut provoquer un incendie ou une explosion.

- Ne pas couper ou gouger à proximité de produits inflammables.
- Surveillez et garder un extincteur à proximité.



DES PIÈCES CHAUDES peuvent provoquer des brûlures et blessures.

- Ne pas toucher le compresseur ou d'autres éléments du circuit air comprimé chauds.
- Laisser l'ensemble se refroidir avant de toucher ou d'effectuer la maintenance.

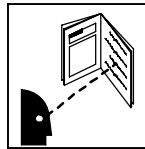

LIRE LES INSTRUCTIONS.

- Lisez le manuel d'instructions avant l'utilisation ou la maintenance de l'appareil.
- Arrêter le moteur et relâcher la pression avant d'effectuer la maintenance.
- N'utiliser que les pièces de rechange recommandées par le constructeur.

2-5. Dangers supplémentaires en relation avec l'installation, le fonctionnement et la maintenance



Risque D'INCENDIE OU D'EXPLOSION.

- Ne pas placer l'appareil sur, au-dessus ou à proximité de surfaces inflammables.
- Ne pas installer l'appareil à proximité de produits inflammables.
- Ne pas surcharger l'installation électrique – s'assurer que l'alimentation est correctement dimensionnée et protégée avant de mettre l'appareil en service.

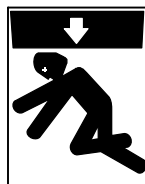

LA CHUTE DE L'APPAREIL peut blesser.

- Utiliser l'anneau de levage pour lever l'appareil et les accessoires correctement installés seuls, PAS les bouteilles de gaz. Ne pas dépasser le poids nominal maximal de l'ocillon (voir les spécifications).
- Ne lever et ne soutenir l'appareil qu'avec de l'équipement approprié et en suivant les procédures adéquates.
- En utilisant des fourches de levage pour déplacer l'unité, s'assurer que les fourches sont suffisamment longues pour dépasser du côté opposé de l'appareil.

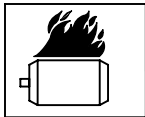

LE SURCHAUFFEMENT peut endommager le moteur électrique.

- Arrêter ou déconnecter l'équipement avant de démarrer ou d'arrêter le moteur.
- Ne pas laisser tourner le moteur trop lentement sous risque d'endommager le moteur électrique à cause d'une tension et d'une fréquence trop faibles.
- Ne pas brancher de moteur de 50 ou de 60 Hz à la prise de 100 Hz, s'il y a lieu.

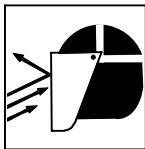

LES ÉTINCELLES VOLANTES risquent de provoquer des blessures.

- Porter un écran facial pour protéger le visage et les yeux.
- Affûter l'électrode au tungstène uniquement à la meuleuse dotée de protecteurs. Cette manœuvre est à exécuter dans un endroit sûr lorsque l'on porte l'équipement homologué de protection du visage, des mains et du corps.
- Les étincelles risquent de causer un incendie – éloigner toute substance inflammable.



DES ORGANES MOBILES peuvent provoquer des blessures.

- Ne pas s'approcher des organes mobiles.
- Ne pas s'approcher des points de coincement tels que des rouleaux de commande.



LES FILS DE SOUDAGE peuvent provoquer des blessures.

- Ne pas appuyer sur la gâchette avant d'en avoir reçu l'instruction.
- Ne pas diriger le pistolet vers soi, d'autres personnes ou toute pièce mécanique en engageant le fil de soudage.

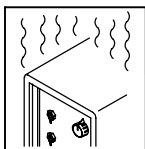

L'EMPLOI EXCESSIF peut SURCHAUFFER L'ÉQUIPEMENT.

- Laisser l'équipement refroidir ; respecter le facteur de marche nominal.
- Réduire le courant ou le facteur de marche avant de poursuivre le soudage.
- Ne pas obstruer les passages d'air du poste.

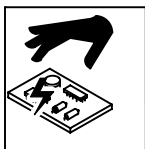

LES CHARGES ÉLECTROSTATIQUES peuvent endommager les circuits imprimés.

- Établir la connexion avec la barrette de terre avant de manipuler des cartes ou des pièces.
- Utiliser des pochettes et des boîtes antistatiques pour stocker, déplacer ou expédier des cartes de circuits imprimés.



UNE REMORQUE QUI BASCULE peut entraîner des blessures.

- Utiliser les supports de la remorque ou des blocs pour soutenir le poids.
- Installer convenablement le poste sur la remorque comme indiqué dans le manuel s'y rapportant.

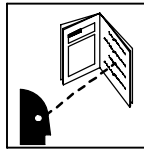

LIRE LES INSTRUCTIONS.

- Lisez le manuel d'instructions avant l'utilisation ou la maintenance de l'appareil.
- N'utiliser que les pièces de rechange recommandées par le constructeur.
- Effectuer la maintenance et le service du moteur et du compresseur d'air suivant les instructions dans ce manuel ou le manuel du moteur/compresseur (si applicable).

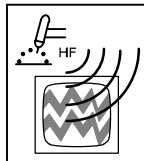

LE RAYONNEMENT HAUTE FRÉQUENCE (H.F.) risque de provoquer des interférences.

- Le rayonnement haute fréquence (H.F.) peut provoquer des interférences avec les équipements de radio-navigation et de communication, les services de sécurité et les ordinateurs.
- Demander seulement à des personnes qualifiées familiarisées avec des équipements électroniques de faire fonctionner l'installation.
- L'utilisateur est tenu de faire corriger rapidement par un électricien qualifié les interférences résultant de l'installation.
- Si le FCC signale des interférences, arrêter immédiatement l'appareil.
- Effectuer régulièrement le contrôle et l'entretien de l'installation.
- Maintenir soigneusement fermés les portes et les panneaux des sources de haute fréquence, maintenir les éclateurs à une distance correcte et utiliser une terre et un blindage pour réduire les interférences éventuelles.

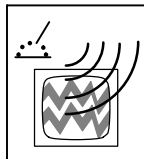

LE SOUDAGE À L'ARC risque de provoquer des interférences.

- L'énergie électromagnétique risque de provoquer des interférences pour l'équipement électronique sensible tel que les ordinateurs et l'équipement commandé par ordinateur tel que les robots.
- Veiller à ce que tout l'équipement de la zone de soudage soit compatible électromagnétiquement.
- Pour réduire la possibilité d'interférence, maintenir les câbles de soudage aussi courts que possible, les grouper, et les poser aussi bas que possible (ex. par terre).
- Veiller à souder à une distance de 100 mètres de tout équipement électronique sensible.
- Veiller à ce que ce poste de soudage soit posé et mis à la terre conformément à ce mode d'emploi.
- En cas d'interférences après avoir pris les mesures précédentes, il incombe à l'utilisateur de prendre des mesures supplémentaires telles que le déplacement du poste, l'utilisation de câbles blindés, l'utilisation de filtres de ligne ou la pose de protecteurs dans la zone de travail.

2-6. Proposition californienne 65 Avertissements

⚠ Les équipements de soudage et de coupage produisent des fumées et des gaz qui contiennent des produits chimiques dont l'État de Californie reconnaît qu'ils provoquent des malformations congénitales et, dans certains cas, des cancers. (Code de santé et de sécurité de Californie, chapitre 25249.5 et suivants)

⚠ Les batteries, les bornes et autres accessoires contiennent du plomb et des composés à base de plomb, produits chimiques dont l'État de Californie reconnaît qu'ils provoquent des cancers et des malformations congénitales ou autres problèmes de procréation. Se laver les mains après manipulation.

Pour les moteurs à essence :

⚠ Les gaz d'échappement des moteurs contiennent des produits chimiques dont l'État de Californie reconnaît qu'ils provoquent des cancers et des malformations congénitales ou autres problèmes de procréation.

Pour les moteurs diesel :

⚠ Les gaz d'échappement des moteurs diesel et certains de leurs composants sont reconnus par l'État de Californie comme provoquant des cancers et des malformations congénitales ou autres problèmes de procréation.

2-7. Principales normes de sécurité

Safety in Welding, Cutting, and Allied Processes, ANSI Standard Z49.1, de Global Engineering Documents (téléphone : 1-877-413-5184, site Internet : www.global.ihs.com).

Recommended Safe Practices for the Preparation for Welding and Cutting of Containers and Piping, American Welding Society Standard AWS F4.1 de Global Engineering Documents (téléphone : 1-877-413-5184, site Internet : www.global.ihs.com).

National Electrical Code, NFPA Standard 70, de National Fire Protection Association, P.O. Box 9101, Quincy, MA 02269-9101 (téléphone : 617-770-3000, site Internet : www.nfpa.org).

Safe Handling of Compressed Gases in Cylinders, CGA Pamphlet P-1, de Compressed Gas Association, 4221 Walney Road, 5th Floor, Chantilly, VA 20151 (téléphone : 703-788-2700, site Internet : www.cganet.com).

Code for Safety in Welding and Cutting, CSA Standard W117.2, de Canadian Standards Association, 5060 Mississauga, Ontario, Canada

L4W 5NS (téléphone : 800-463-6727 ou à Toronto 416-747-4044, site Internet : www.csa-international.org).

Safe Practice For Occupational And Educational Eye And Face Protection, ANSI Standard Z87.1, de American National Standards Institute, 11 West 43rd Street, New York, NY 10036-8002 (téléphone : 212-642-4900, site Internet : www.ansi.org).

Standard for Fire Prevention During Welding, Cutting, and Other Hot Work, NFPA Standard 51B, de National Fire Protection Association, P.O. Box 9101, Quincy, MA 02269-9101 (téléphone : 617-770-3000, site Internet : www.nfpa.org).

OSHA, Occupational Safety and Health Standards for General Industry, Title 29, Code of Federal Regulations (CFR), Part 1910, Subpart Q, and Part 1926, Subpart J, de U.S. Government Printing Office, Superintendent of Documents, P.O. Box 371954, Pittsburgh, PA 15250-7954 (téléphone : 1-866-512-1800) (il y a 10 bureaux régionaux--le téléphone de la région 5, Chicago, est 312-353-2220, site Internet : www.osha.gov).

2-8. Information EMF

Considérations sur le soudage et les effets de basse fréquence et des champs magnétiques et électriques.

Le courant de soudage, pendant son passage dans les câbles de soudage, causera des champs électromagnétiques. Il y a eu et il y a encore un certain souci à propos de tels champs. Cependant, après avoir examiné plus de 500 études qui ont été faites pendant une période de recherche de 17 ans, un comité spécial ruban bleu du National Research Council a conclu : « L'accumulation de preuves, suivant le jugement du comité, n'a pas démontré que l'exposition aux champs magnétiques et champs électriques à haute fréquence représente un risque à la santé humaine ». Toutefois, des études sont toujours en cours et les preuves continuent à être examinées. En attendant que les conclusions finales de la recherche soient établies, il vous serait souhaitable de réduire votre exposition aux champs électromagnétiques pendant le soudage ou le coupage.

Pour réduire les champs magnétiques sur le poste de travail, appliquer les procédures suivantes :

1. Garder les câbles ensemble, les torsader, les scotcher, ou les recouvrir d'une housse.
2. Disposer les câbles d'un côté et à distance de l'opérateur.
3. Ne pas courber pas et ne pas entourer pas les câbles autour de votre corps.
4. Garder le poste de soudage et les câbles le plus loin possible de vous.
5. Connecter la pince sur la pièce aussi près que possible de la soudure.

En ce qui concerne les implants médicaux :

Les porteurs d'implants doivent d'abord consulter leur médecin avant de s'approcher des opérations de soudage à l'arc, de soudage par points, de gougeage, du coupage plasma ou de chauffage par induction. Si le médecin approuve, il est recommandé de suivre les procédures précédentes.

SECTION 3 – DEFINITIONS

3-1. Warning Label Definitions

S-177 571

1 Remove unit from shipping crate. Remove Owner's Manual from unit. Follow instructions to install muffler.

2 Read Owner's Manual. Read labels on unit.

3 Use Diesel Fuel only, and fill fuel tank. Leave room for expansion.

4 Warning! Watch Out! There are possible hazards as shown by the symbols. Read Owner's Manual. Follow instructions to activate battery.

5 Check oil level. Add oil if necessary.

6 During the first 50 hours of operation, keep welding load above 200 amperes. Do not weld below 200 amperes of output.

7 After the first 50 hours of operation, change the oil and oil filter.

0 – 50 h Std. 200A↑ 0-200A

50 h Std.

API CD-MIL L 2104D, CD/SE, CD/SF

3/96

Notes



















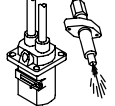
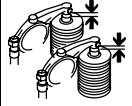





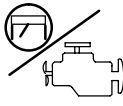







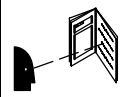

Work like a Pro!

Pros weld and cut safely. Read the safety rules at the beginning of this manual.

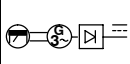
3-2. Symbols And Definitions

 Some symbols are found only on CE products.

	Stop Engine		Fast (Run, Weld/Power)		Slow (Idle)		Start Engine
	Starting Aid (Preheat)		Battery (Engine)		Engine Oil Pressure		Engine Oil
	Check Injectors/Pump		Check Valve Clearance		Fuel		Protective Earth (Ground)
+	Positive	-	Negative		Certified/Trained Mechanic		Welding Arc
A	Amperes	V	Volts		Panel/Local		Remote
	Engine		Air Temperature Or Engine Temperature		Output		Alternating Current
	Stick (SMAW) Welding		Constant Current (CC)		MIG (GMAW) Welding		TIG (GTAW)
	Time	h	Hours	s	Seconds		Single Phase
	Three Phase		Read Operator's Manual		Circuit Protector		Do Not Switch While Welding
	Electrode Connection		Work Connection		Engine-Driven, Three-Phase Alternator With Rectifier	Hz	Hertz
X	Duty Cycle	U₀	Rated No Load Voltage (Average)	U₂	Conventional Load Voltage	n	Rated Load Speed
n₁	Rated Idle Speed	n₀	Rated No Load Speed	I	Current	I₂	Rated Welding Current
	Contactor On		Arc Force (Dig)		Lift-Arc TIG		

SECTION 4 – SPECIFICATIONS

4-1. Weld, Power, And Engine Specifications

Welding Mode	Weld Output Range	Rated Welding Output	Maximum Open-Circuit Voltage	Generator Power Rating	Engine	Fuel Capacity
CC/DC	Stick: 40 – 410 A TIG: 20 – 410 A	400 A, 23 Volts DC, 30% Duty Cycle 300 A, 32 Volts DC 60% Duty Cycle 250 A, 30 Volts DC 100% Duty cycle	60	Single-Phase, 10 kVA/kW, 91/45 A, 120/240 V AC, 60 Hz	Deutz D2008L04 Water-Cooled Four-Cylinder 24.2 HP Diesel Engine	11 gal (41.6 L)
CV/DC	14 – 40 V	400 A, 23 Volts DC, 30% Duty Cycle 300 A, 29 Volts DC 60% Duty Cycle 250 A, 26.5 Volts DC 100% Duty cycle				

4-2. Dimensions, Weights, And Operating Angles

Dimensions	
Height	32 in (813 mm) 35-3/4 in (908 mm) (to top of lift eye)
Width	26-1/4 in (667 mm) (mtg. brackets turned in) 28-3/4 in (730 mm) (mtg. brackets turned out)
Depth	56 in (1422 mm)
A	56 in (1422 mm)
B	54 in (1372 mm)
C	52 in in (1321 mm)
D	2 in (51 mm)
E	26 in (660 mm)
F	7/8 in (22 mm)
G	27-3/4 in (705 mm)
H	9/16 in (14 mm) Dia. 4 Holes
Weight	
With fuel: 1290 lb (585 kg) No fuel: 1208 lb (548 kg)	
Lifting Eye Weight Rating: 1500 lb (680 Kg) Maximum	

⚠ Do not exceed tilt angles or engine could be damaged or unit could tip.

⚠ Do not move or operate unit where it could tip.

4-3. Volt-Ampere Curves

The volt-ampere curves show the minimum and maximum voltage and amperage output capabilities of the welding generator. Curves of all other settings fall between the curves shown.

A. Stick Mode

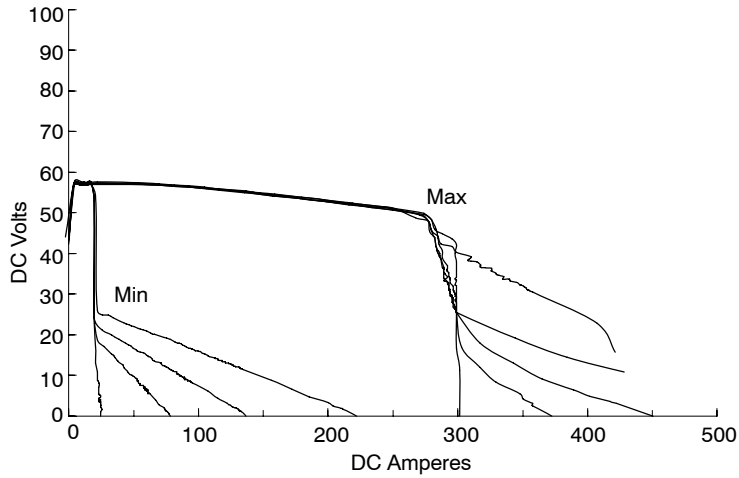

B. MIG Mode

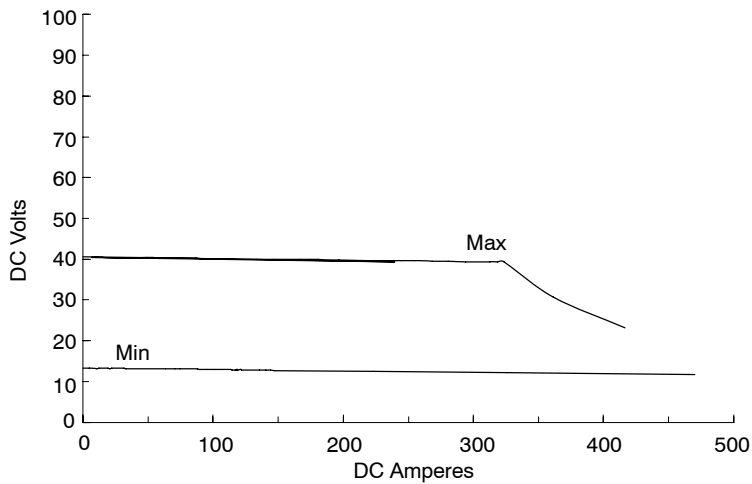

C. TIG Mode

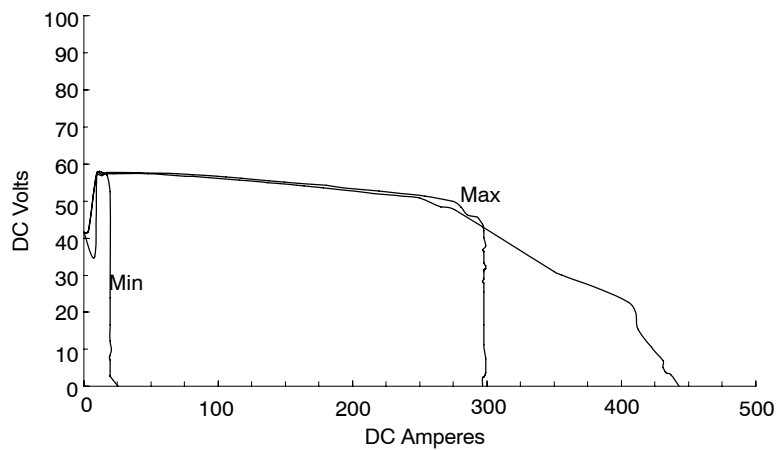

4-4. Fuel Consumption

The curve shows typical fuel use under weld or power loads.

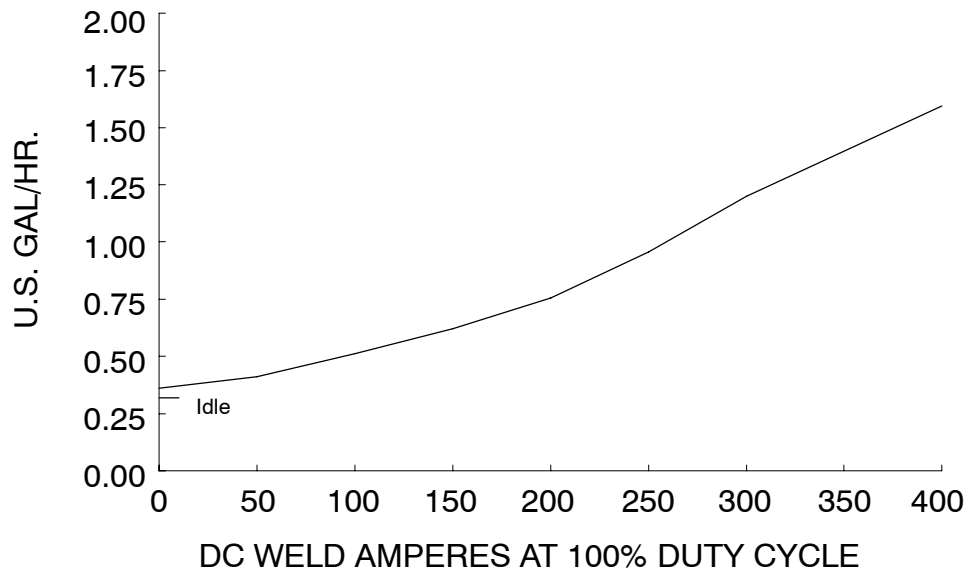

237 299

4-5. Duty Cycle And Overheating

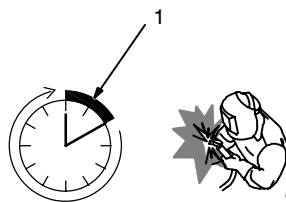
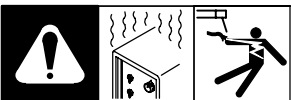

1 100% Duty Cycle

Duty Cycle is percentage of 10 minutes that unit can weld at rated load without overheating.

 This unit is rated for welding at 250 amperes continuously.

NOTICE - Exceeding duty cycle can damage unit and void warranty.

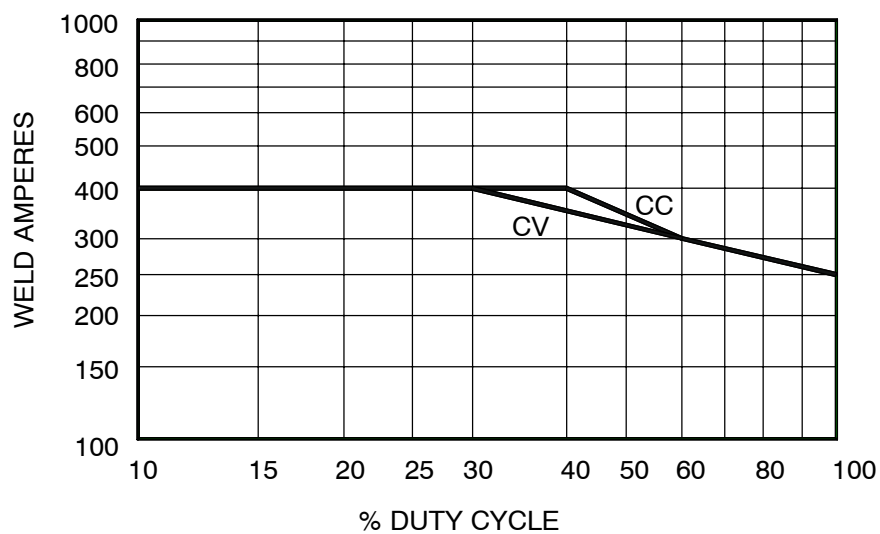

217 515

SECTION 5 – INSTALLATION

5-1. Installing Welding Generator

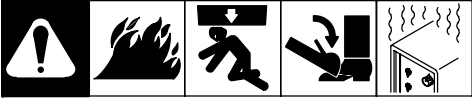

⚠ Do not move or operate unit where it could tip.

⚠ Always securely fasten welding generator onto transport vehicle or trailer and comply with all DOT and other applicable codes.

NOTICE – Do not install unit where air flow is restricted or engine may overheat.

☞ See Section 4-2 for lifting eye rating.

☞ See Section 5-2 for mounting information.

Movement

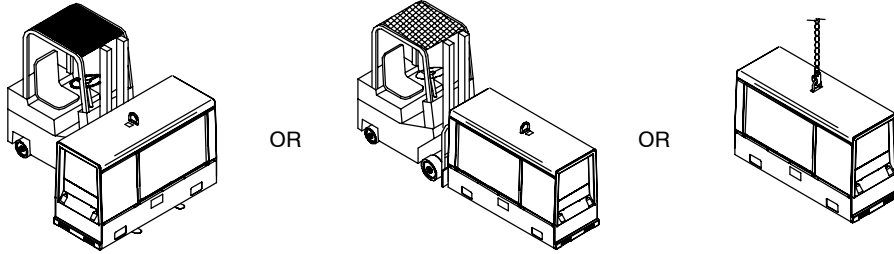

Location/Airflow Clearance

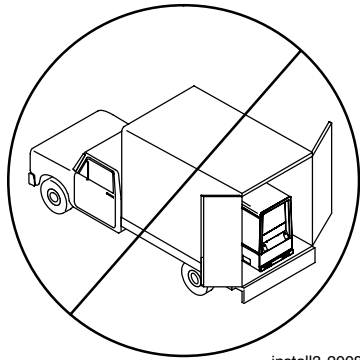
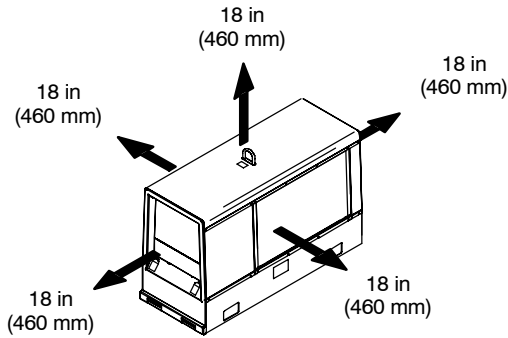
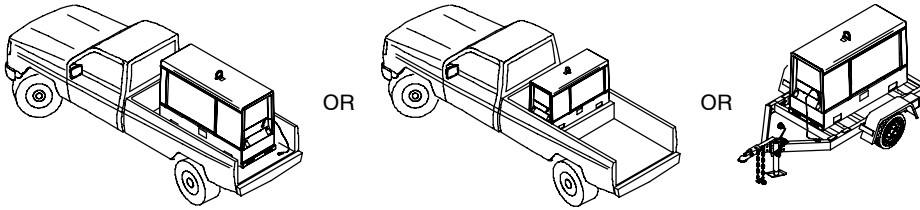

install3 2008-01 – Ref. 800 652 / Ref. 800 477-A / 803 274 / 804 712

5-2. Mounting Welding Generator



Supporting The Unit

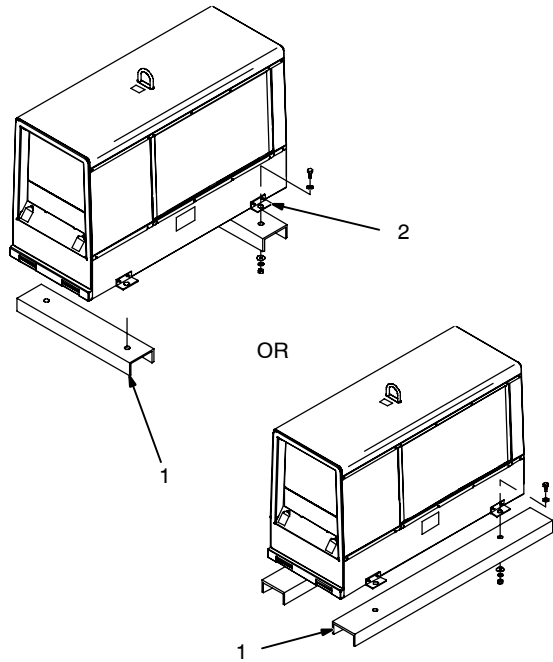
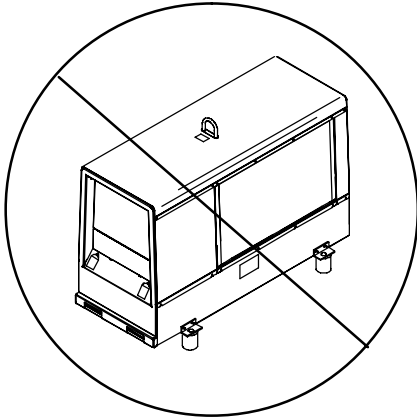

⚠ Do not weld on base. Welding on base can cause fuel tank fire or explosion. Weld only on the four mounting brackets or bolt unit down.

NOTICE – Do not mount unit by supporting the base only at the four mounting brackets. Use cross-supports to adequately support unit and prevent damage to base.

Mounting Surface:

1 Cross-Supports
2 Mounting Brackets (Supplied)
Mount unit on flat surface or use cross-supports to support base. Secure unit with mounting brackets.

3 1/2 in Bolt And Washer (Minimum – Not Supplied)
4 3/8-16 x 1 in Screws (Supplied)

To Bolt Unit In Place:

Remove hardware securing the four mounting brackets to the base. Reverse brackets and reattach to base with original hardware.

Mount unit to truck or trailer with 1/2 in (12 mm) or larger hardware (not supplied).

To Weld Unit In Place:

Weld unit to truck or trailer only at the four mounting brackets.

Using Mounting Brackets

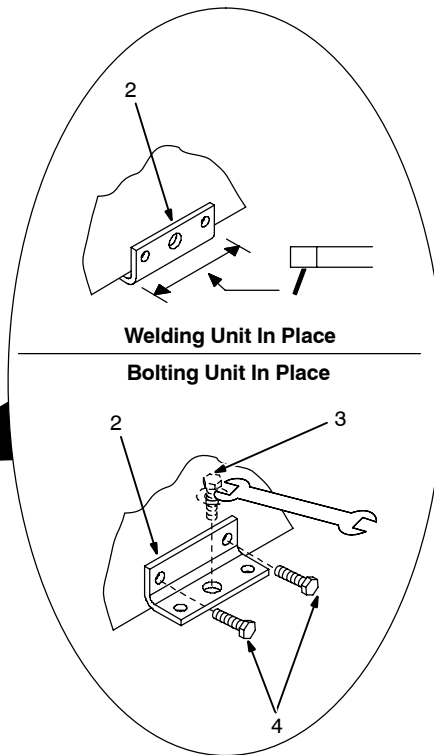
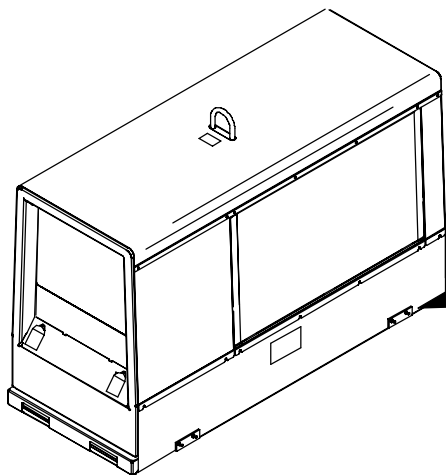

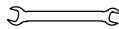
Tools Needed:
 9/16 in

install3 2008--01 803 274 / 200 864-A / 803 231

5-3. Grounding Generator To Truck Or Trailer Frame

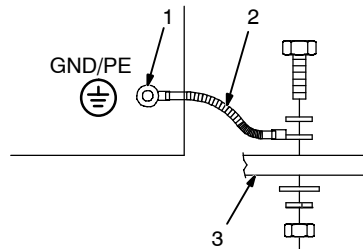
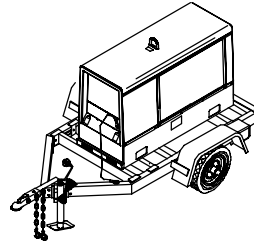
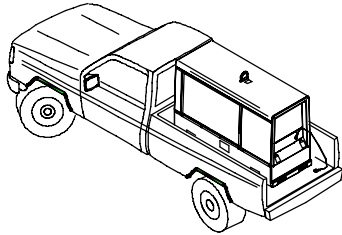

⚠ Always ground generator frame to vehicle frame to prevent electric shock and static electricity hazards.

⚠ Also see AWS Safety & Health Fact Sheet No. 29, Grounding of Portable And Vehicle Mounted Welding Generators.

⚠ Bed liners, shipping skids, and some running gear insulate the welding generator from the vehicle frame. Always connect a ground wire from the generator equipment grounding terminal to bare metal on the vehicle frame as shown.

⚠ If unit does not have GFCI receptacles, use GFCI-protected extension cord.

- 1 Equipment Grounding Terminal (On Front Panel)
- 2 Grounding Cable (Not Supplied)
- 3 Metal Vehicle Frame

Connect cable from equipment ground terminal to metal vehicle frame. Use #10 AWG or larger insulated copper wire.

⚠ *Electrically bond generator frame to vehicle frame by metal-to-metal contact.*

rot_grnd 2008-01 – 800 652-D

5-4. Rating Label Location

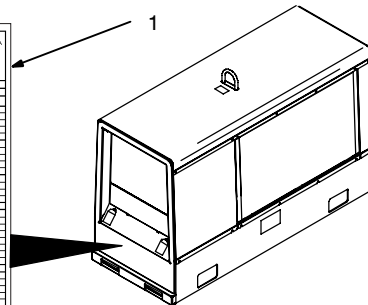
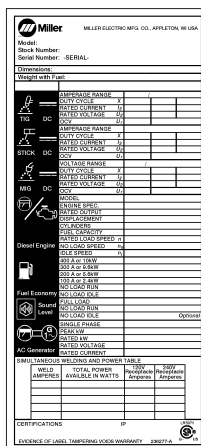

1 Rating Label – Typical

Locate rating label on unit. Label provides information such as weld output ratings, generator ratings, and engine information.

⚠ *Evidence of label tampering voids warranty.*

rot_label 2008-01 – 804 712

5-5. Installing Exhaust Pipe

⚠ Stop engine and let cool.

☞ *Point exhaust pipe in desired direction but always away from front panel and direction of travel.*

Tools Needed:

1/2 in

803 582 / Ref. 217 357-A

Notes

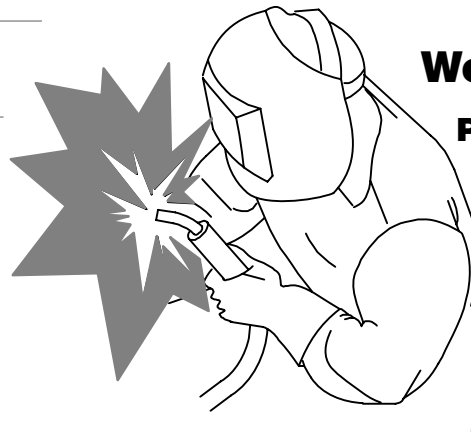

Work like a Pro!

Pros weld and cut safely. Read the safety rules at the beginning of this manual.

5-6. Activating The Dry Charge Battery (If Applicable)



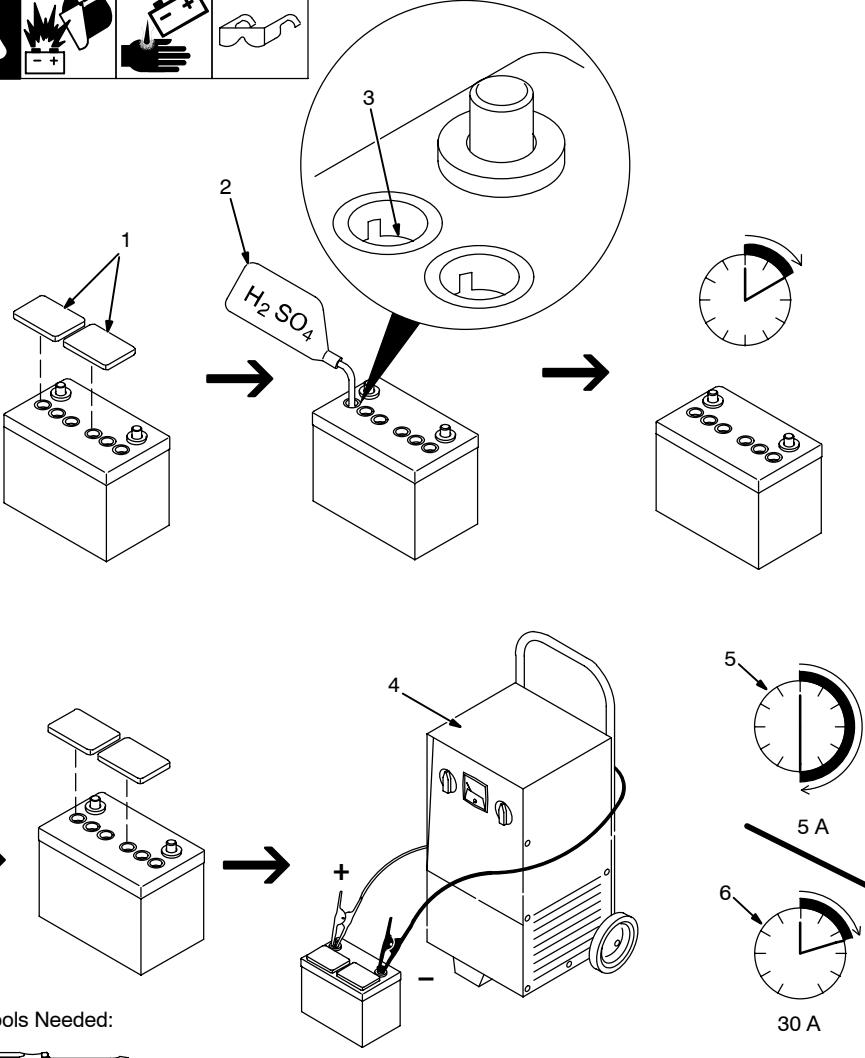

⚠ Always wear a face shield, rubber gloves and protective clothing when working on a battery.

Remove battery from unit.

- 1 Vent Caps
- 2 Sulfuric Acid Electrolyte (1.265 Specific Gravity)
- 3 Well

Fill each cell with electrolyte to **bottom** of well (maximum).

⚠ Do not overfill battery cells.

Wait ten minutes and check electrolyte level. If necessary, add electrolyte to raise to proper level. Reinstall vent caps.

- 4 Battery Charger

⚠ Read and follow all instructions supplied with battery charger.

- 5 5 Amperes For 30 Minutes Charge Time
- 6 30 Amperes For 12 Minutes Charge Time

Charge battery. Disconnect charging cables and install battery.

☞ When electrolyte is low, add only distilled water to cells to maintain proper level.

Tools Needed:

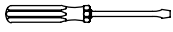

drybatt 12008-01 – S-0886

5-7. Connecting The Battery



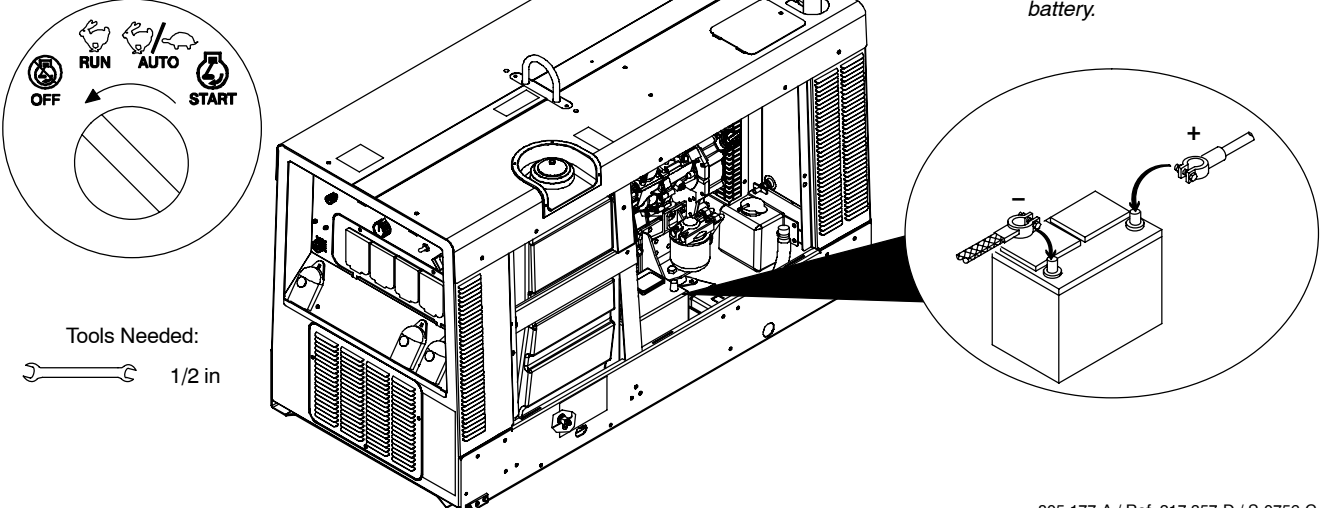

⚠ Connect negative (-) battery cable last.

☞ Close door after connecting battery.

Tools Needed:

 1/2 in

805 177-A / Ref. 217 357-D / S-0756-C

5-8. Engine Prestart Checks

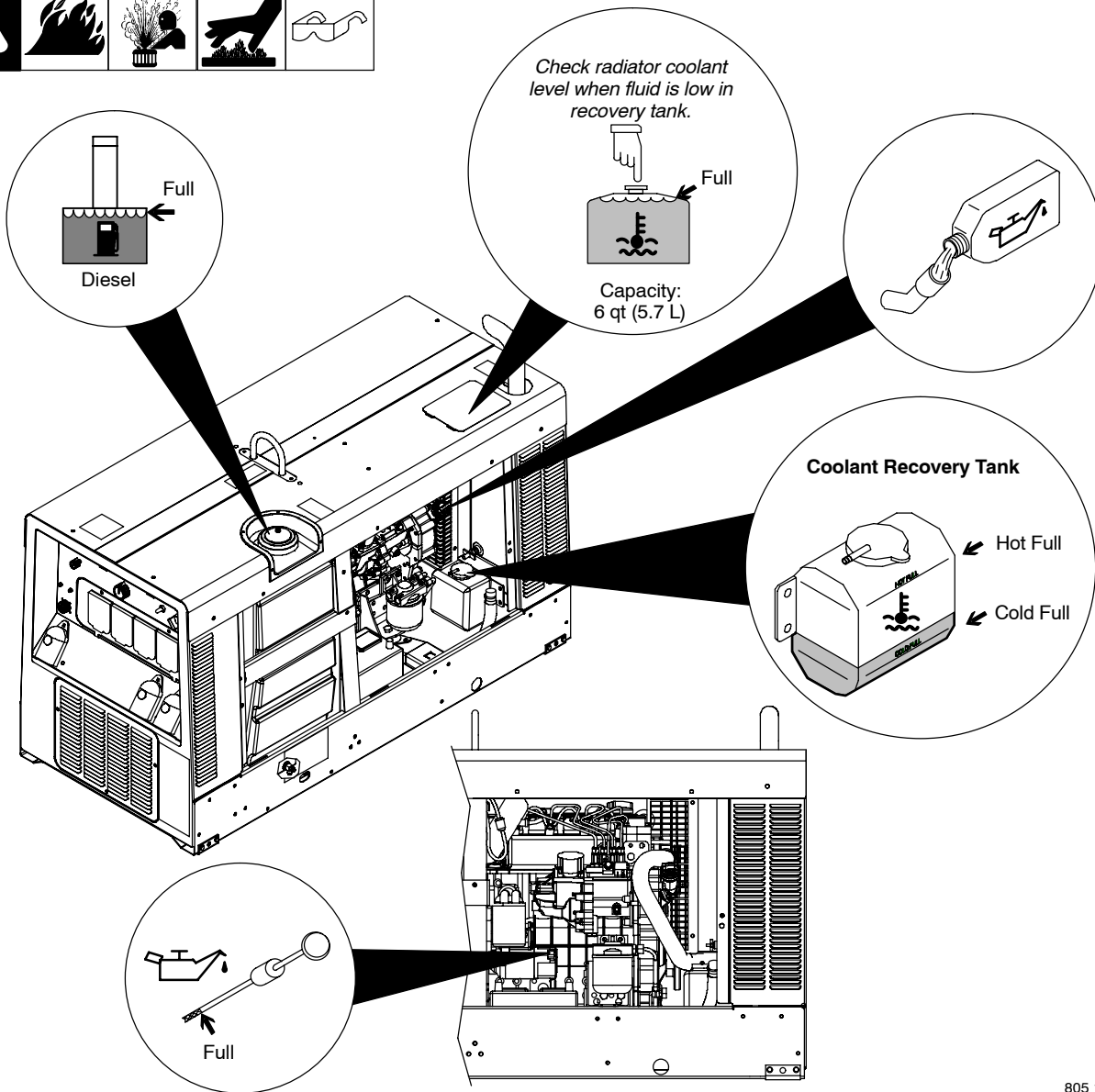

805 177-A

☞ Check all engine fluids daily.

Engine must be cold and on a level surface. Unit is shipped with 20W break-in oil.

Automatic shutdown system stops engine if oil pressure is too low or coolant temperature is too high.

☞ This unit has a low oil pressure shutdown switch. However, some conditions may cause engine damage before the engine shuts down. Check oil level often and do not use the oil pressure shutdown system to monitor oil level.

Follow run-in procedure in engine manual. If unburned fuel and oil collect in exhaust pipe during run-in, see Section 10.

Fuel

NOTICE – Do not use gasoline. Gasoline will damage engine.

The unit is shipped with enough fuel to prevent air from entering fuel system. Add fresh diesel fuel before starting (see engine maintenance label for fuel specifications). Leave filler neck empty to allow room for expansion.

Engine stops if fuel level is low.

Oil

After fueling, check oil with unit on level surface. If oil is not up to full mark on dipstick, add oil (see maintenance label).

Coolant

Check coolant level in radiator before starting unit the first time. If necessary, add coolant to radiator until coolant level is at bottom of filler neck.

Check coolant level in recovery tank daily. If necessary, add coolant to recovery tank until coolant level is between Cold Full and Hot Full levels. If recovery tank coolant level was low, also check coolant level in radiator. Add coolant if level is below bottom of radiator filler neck.

Unit is shipped with an engine coolant mixture of water and ethylene glycol base anti-freeze rated to -34°F (-37°C). Add anti-

freeze to mixture if using the unit in temperatures below -34°F (-37°C).

Keep radiator and air intake clean and free of dirt.

NOTICE – Incorrect engine temperature can damage engine. Do not run engine without a properly working thermostat and radiator cap.

☞ To improve cold weather starting:

Use Preheat switch (see Section 6-1).

Keep battery in good condition. Store battery in warm area.

Use fuel formulated for cold weather (diesel fuel can gel in cold weather). Contact local fuel supplier for fuel information.

Use correct grade oil for cold weather (see Section 8-2).

5-9. Connecting To Weld Output Terminals

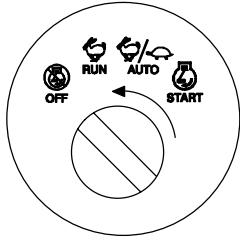

⚠ Stop engine.

- 1 Work/Negative (-) Weld Output Terminal
- 2 CV (wire) Weld Output Terminal
- 3 CC (Stick/TIG) Weld Output Terminal

⚠ Failure to properly connect weld cables may cause excessive heat and start a fire, or damage your machine.

- 4 Weld Output Terminal
- 5 Supplied Weld Output Terminal Nut
- 6 Weld Cable Terminal
- 7 Copper Bar

Remove supplied nut from weld output terminal. Slide weld cable terminal onto weld output terminal and secure with nut so that weld cable terminal is tight against copper bar. **Do not place anything between weld cable terminal and copper bar. Make sure that the surfaces of the weld cable terminal and copper bar are clean.**

Tools Needed:

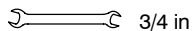

Stick and TIG Welding

For Stick and TIG welding Direct Current Electrode Positive (DCEP), connect electrode holder cable to CC (Stick/TIG) terminal on right and work cable to Work/Negative (-) terminal on left.

For Direct Current Electrode Negative (DCEN), reverse cable connections.

Use Process/Contactor switch to select type of weld output (see Section 6-3).

MIG and FCAW Welding

For MIG and FCAW welding Direct Current Electrode Positive (DCEP) connect wire feeder cable to CV (Wire) terminal on right and work cable to Work/Negative (-) terminal on left. Use Process/Contactor switch to select type of weld output (see Section 6-3).

For Direct Current Electrode Negative (DCEN), reverse cable connections.

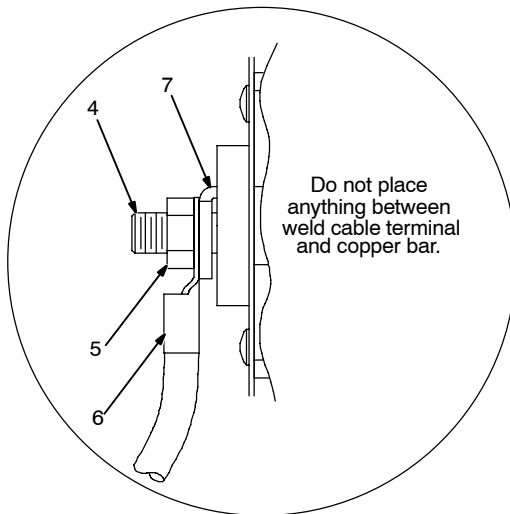
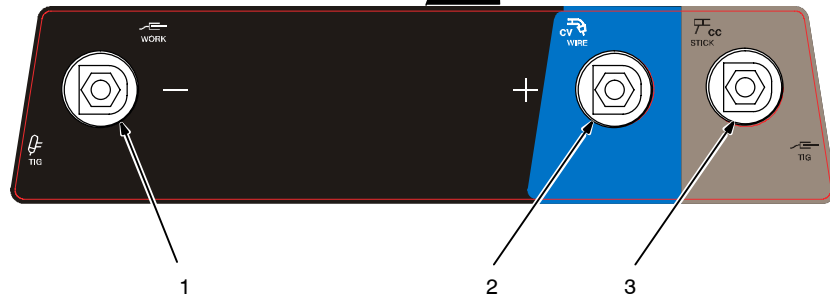
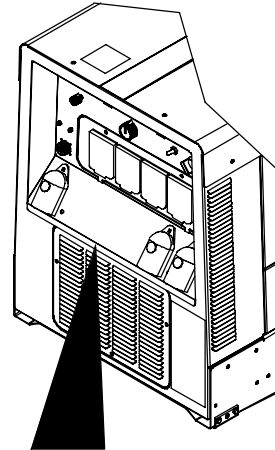

Correct Installation

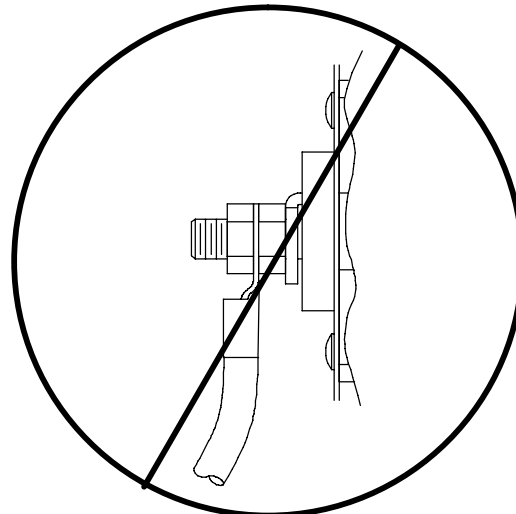

Incorrect Installation

803 562 / 803 778-A

5-10. Selecting Weld Cable Sizes*

 <p>Weld Output Terminals</p> <p>⚠ Stop engine before connecting to weld output terminals.</p> <p>⚠ Do not use worn, damaged, undersized, or poorly spliced cables.</p>	Weld Cable Size** and Total Cable (Copper) Length in Weld Circuit Not Exceeding***								
	Welding Amperes	100 ft (30 m) or Less		150 ft (45 m)	200 ft (60 m)	250 ft (70 m)	300 ft (90 m)	350 ft (105 m)	400 ft (120 m)
		10 – 60% Duty Cycle	60 – 100% Duty Cycle	10 – 100% Duty Cycle					
100	4 (20)	4 (20)	4 (20)	3 (30)	2 (35)	1 (50)	1/0 (60)	1/0 (60)	
150	3 (30)	3 (30)	2 (35)	1 (50)	1/0 (60)	2/0 (70)	3/0 (95)	3/0 (95)	
200	3 (30)	2 (35)	1 (50)	1/0 (60)	2/0 (70)	3/0 (95)	4/0 (120)	4/0 (120)	
250	2 (35)	1 (50)	1/0 (60)	2/0 (70)	3/0 (95)	4/0 (120)	2 ea. 2/0 (2x70)	2 ea. 2/0 (2x70)	
300	1 (50)	1/0 (60)	2/0 (70)	3/0 (95)	4/0 (120)	2 ea. 2/0 (2x70)	2 ea. 3/0 (2x95)	2 ea. 3/0 (2x95)	
350	1/0 (60)	2/0 (70)	3/0 (95)	4/0 (120)	2 ea. 2/0 (2x70)	2 ea. 3/0 (2x95)	2 ea. 3/0 (2x95)	2 ea. 4/0 (2x120)	
400	1/0 (60)	2/0 (70)	3/0 (95)	4/0 (120)	2 ea. 2/0 (2x70)	2 ea. 3/0 (2x95)	2 ea. 4/0 (2x120)	2 ea. 4/0 (2x120)	
500	2/0 (70)	3/0 (95)	4/0 (120)	2 ea. 2/0 (2x70)	2 ea. 3/0 (2x95)	2 ea. 4/0 (2x120)	3 ea. 3/0 (3x95)	3 ea. 3/0 (3x95)	

* This chart is a general guideline and may not suit all applications. If cables overheat, use next size larger cable.
 **Weld cable size (AWG) is based on either a 4 volts or less drop or a current density of at least 300 circular mils per ampere.
 () = mm² for metric use
 ***For distances longer than those shown in this guide, call a factory applications representative at 920-735-4505.

S-0007-F

Notes

5-11. Connecting To Remote 14 Receptacle RC14

LDR-14 long distance remote (includes 120 V receptacle)

803 562

REMOTE 14	Socket*	Socket Information
24 VOLTS AC OUTPUT (CONTACTOR)	A	24 volts ac. Protected by supplementary protector CB8.
	B	Contact closure to A completes 24 volt ac contactor control circuit.
REMOTE OUTPUT CONTROL	C	Output to remote control: +10 volts dc in MIG mode; 0 to +10 volts dc in Stick or TIG mode.
	D	Remote control circuit common.
	E	DC input command signal: 0 to +10 volts from min. to max. of remote control with Voltage/ Amperage Adjust control at max.
115 VOLTS AC OUTPUT (CONTACTOR)	I	115 volts, 10 amperes, 60 Hz ac. Protected by supplementary protector CB7.
	J	Contact closure to I completes 115 volt ac contactor control circuit.
A/V AMPERAGE VOLTAGE	F	Current feedback: 1 volt per 100 amperes.
	H	Voltage feedback: 1 volt per 10 arc volts.
GND	K	Chassis common.
NEUTRAL	G	Circuit common for 24 and 115 volt ac circuit.

*The remaining sockets are not used.

Notes

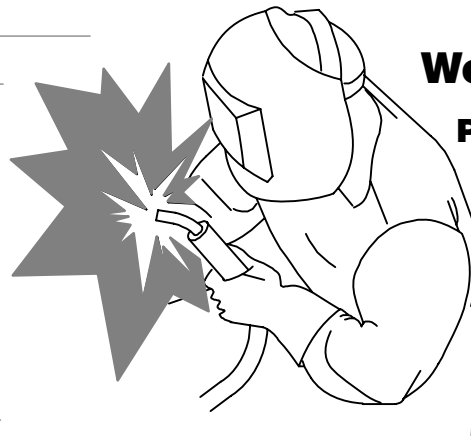

Work like a Pro!

Pros weld and cut safely. Read the safety rules at the beginning of this manual.

SECTION 6 – OPERATING WELDING GENERATOR

6-1. Front Panel Controls (See Section 6-2)

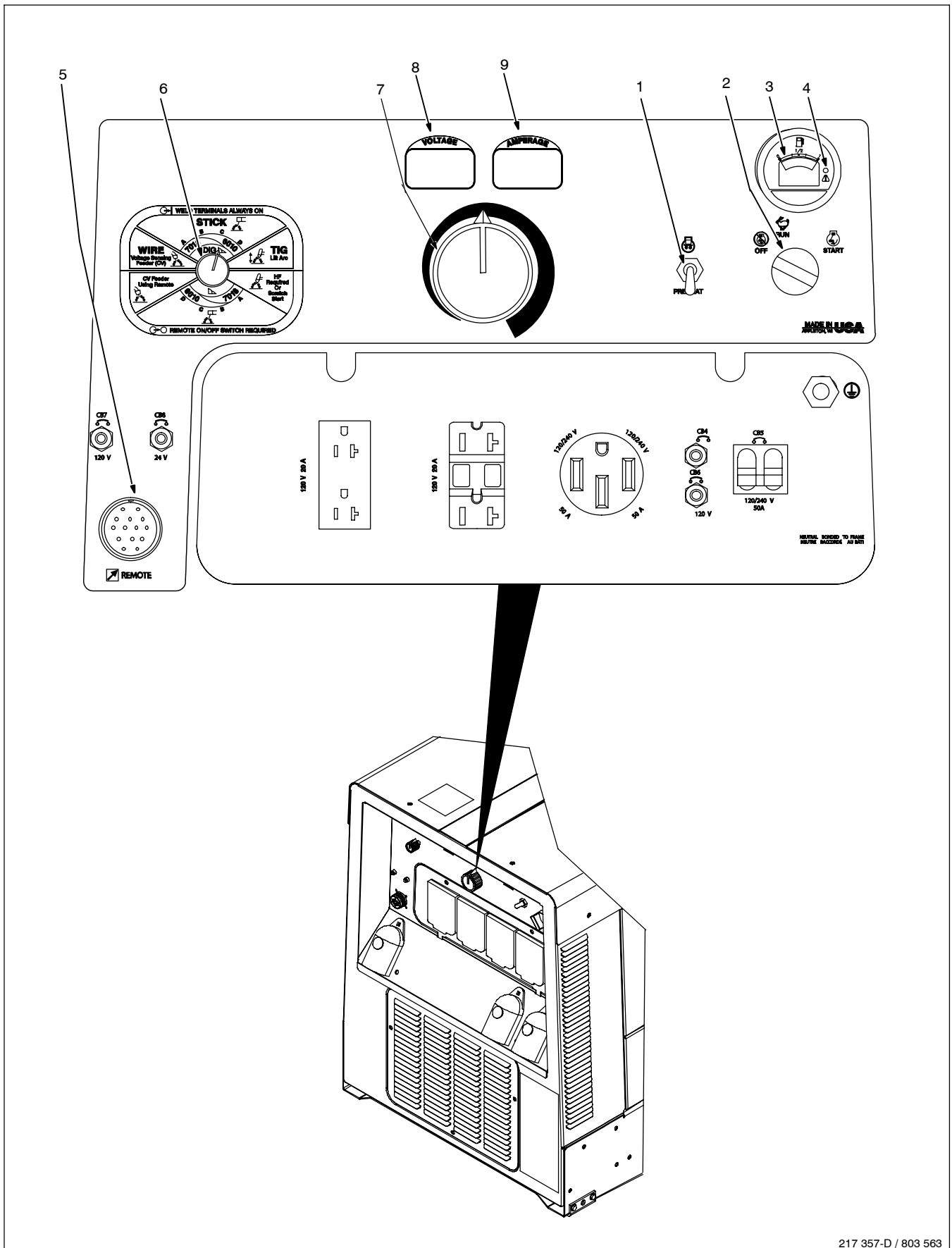

6-2. Description Of Front Panel Controls (See Section 6-1)

<p>Engine Starting Controls</p>										
<p>1 Preheat Switch</p>	<p>To check fuel level or engine hours when engine is not running, turn Engine Control switch to Run position.</p>									
<p>Use switch to energize starting aid for cold weather starting (see starting instructions following).</p>	<p>4 Engine Indicator Light</p> <p>Light goes on and engine stops if fuel is low, engine temperature exceeds 230° F (110° C) or engine oil pressure is below 10 psi (69 kPa).</p> <p> Normal engine temperature is 180 - 203° F (82 - 95° C). Normal oil pressure is 30 - 60 psi (207 - 414 kPa).</p> <p>NOTICE - Do not run engine until trouble is fixed.</p>									
<p>2 Engine Control Switch</p>	<p>6 Process/Contactor Switch</p> <p>See Section 6-3 for Process/Contactor switch information.</p>									
<p>Use switch to start engine, select engine speed (if unit has auto idle option), and stop engine.</p>	<p>7 Voltage/Amperage Control</p> <p>With Process/Contactor switch in any Stick or TIG setting, use control to adjust amperage. With Process/Contactor switch in any Wire (MIG) position, use control to adjust voltage. With Voltage/Amperage Adjust Switch in Remote position, control limits the remote amperage in Stick or TIG mode, but has no effect in Wire (MIG) modes.</p>									
<p>In Run position, engine runs at weld/power speed. In Auto position (optional), engine runs at idle speed at no load and weld speed with load applied.</p>	<p>Weld Meters</p> <p> Weld meters also work in combination to display troubleshooting help codes (see Section 8-10).</p>									
<p>To Start:</p>	<p>8 DC Voltmeter</p> <p>Voltmeter displays preset voltage (MIG welding) with contactor off, and actual output voltage with the contactor on. Voltmeter displays voltage at the weld output terminals, but not necessarily the welding arc due to resistance of cable and connections.</p>									
<p>NOTICE - Do not use ether.</p>	<p>To set voltage, turn contactor off and turn Process/Contactor switch to Wire position. Turn V/A control until desired voltage is displayed on Voltmeter. When welding is finished, voltmeter displays weld voltage and then defaults to preset voltage.</p>									
<p> If engine does not start, let engine come to a complete stop before attempting restart.</p>	<p>9 DC Ammeter</p> <p>Ammeter displays preset amperage (Stick and TIG only) when not welding, and actual output amperage when welding.</p> <p>To set amperage, turn Process/Contactor switch to Stick or TIG position. Turn V/A control until desired amperage is displayed on Ammeter. When welding is finished, ammeter displays weld amperage and then defaults to preset amperage.</p>									
<p>Above 32° F (0° C): turn Engine Control switch to Start. Release Engine Control switch when engine starts.</p>	<p>Weld Controls</p> <p>5 Remote Control Receptacle</p> <p>Use receptacle to connect remote controls, wire feeders, and tools.</p> <p>When a remote control is connected to the Remote receptacle, the Auto Sense Remote feature automatically switches voltage/amperage control to the remote control (see Section 5-11).</p> <p>With remote control connected, weld output is determined by a combination of front panel and remote control voltage/amperage settings.</p> <p>If no remote control is connected to the Remote receptacle, the front panel Voltage/Amperage control adjusts voltage and amperage.</p> <p> If a remote device connected to Remote Receptacle RC14 is faulty or is disconnected during operation, the meters display Help 25 (see Section 8-10). Clear fault by stopping and restarting the unit or by turning Process/Contactor switch to another position.</p>									
<p>Below 32° F (0° C): turn engine control switch to Auto position. Push Preheat switch up for 6 seconds. Turn Engine Control switch to Start. Release Engine Control switch and Preheat switch when engine starts.</p>	<p>Engine Gauges, Meters, And Lights</p> <p> See Section 6-6 for complete fuel/hour gauge information.</p>									
<p> Do not operate Preheat switch for more than 60 seconds at a time.</p>	<p>3 Fuel/Hour Gauge</p> <p>Use gauge to check fuel level, total engine operating hours, or hours to oil change.</p>									
<p>To Stop: turn Engine Control switch to Off position.</p>										

6-3. Process/Contactor Switch

1 Process/Contactor Switch

⚠ Weld output terminals are energized when Process/Contactor switch is in a Weld Terminals Always On position and the engine is running.

Use switch to select weld process and weld output on/off control (see table below).

Place switch in Remote On/Off Switch Required positions to turn weld output on and off with a device connected to the Remote 14 receptacle.

Place switch in Weld Terminals Always On positions for weld output to be on whenever the engine is running.

Use Stick mode for air carbon arc (CAC-A) cutting and gouging.

When switch is in Stick mode, select one of four arc drive (dig) settings to provide additional amperage during low voltage (short arc length) conditions and prevent “sticking” electrodes. Turn control from A to D to increase arc drive (dig) from min to max.

Use the Lift-Arc TIG mode for TIG (GTAW) welding using the Lift-Arc TIG starting procedure (see Section 6-4).

803 562 / 217 357

Process/Contactor Switch Settings

Switch Setting	Process	Output On/Off Control	Engine Auto Idle (Optional)
Remote On/Off Switch Required – TIG HF Required Or Scratch Start	GTAW With HF Unit, Pulsing Device, Or Remote Control	At Remote 14 Receptacle	Active
Remote On/Off Switch Required – Stick	Stick (SMAW) With Remote On/Off	At Remote 14 Receptacle	Active
Remote On/Off Switch Required – CV Feeder Using Remote	MIG (GMAW) w/Constant Speed Feeder	At Remote 14 Receptacle	Active
Weld Terminals Always On – Wire	MIG (GMAW) w/Voltage Sensing Feeder	Electrode Hot	Active
Weld Terminals Always On – Stick	Stick (SMAW), Air Carbon Arc (CAC-A) Cutting And Gouging	Electrode Hot	Active
Weld Terminals Always On – TIG Lift-Arc	TIG Lift-Arc (GTAW)	Electrode Hot	Active

6-4. Lift-Arc™ TIG With Crater-Out And Auto-Stop™



Arc Start With Lift-Arc

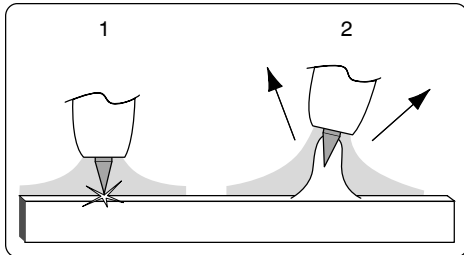

Arc End With Crater-Out

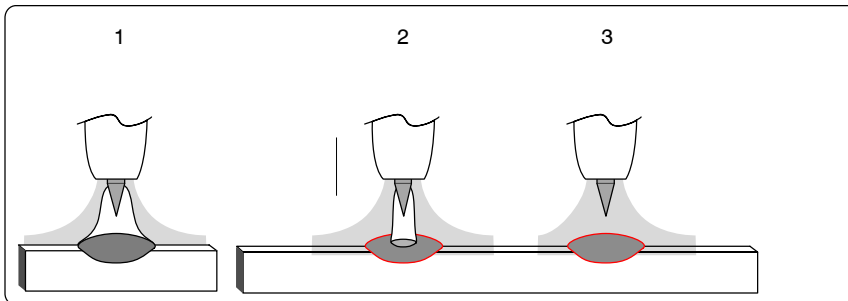

OR

Arc End With Auto-Stop

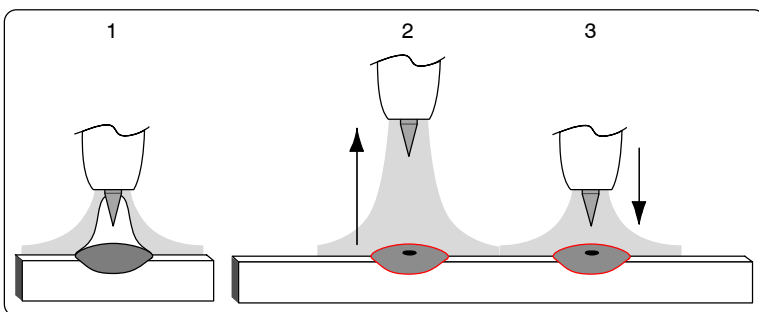

Arc Start With Lift-Arc TIG

Lift-Arc is used for the DCEN GTAW process when HF Start method is not permitted.

Select Lift-Arc at Process/Contactor switch.

Turn gas on.

- 1 Touch or scratch.
- 2 Lift at any angle.

Touch tungsten electrode to workpiece at weld start point. Slowly lift electrode. Arc is started when electrode is lifted.

Maintain shielding gas coverage and eliminate tungsten and workpiece contamination by using Auto-Crater or Auto-Stop to end the arc.

Arc End With Crater-Out:

 Momentary contact switch required to start crater-out.

- 1 While welding.
- 2 Close momentary contact switch to start Crater-out end (current is reduced).
- 3 Shielding gas continues until shut off.

Arc End With Auto-Stop:

- 1 While welding.
- 2 Lift torch to start Auto-Stop. Arc stops.
- 3 Move torch back down to maintain gas coverage and prevent contamination.

6-5. Remote Voltage/Amperage Control

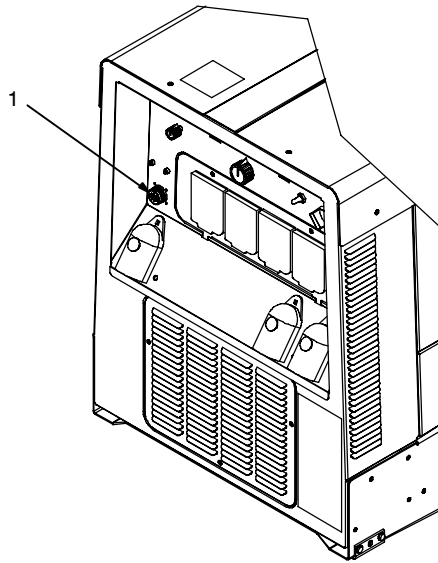

1 Remote 14 Receptacle RC14

Connect optional remote control to RC14 (see Section 5-11).

When a remote control is connected to the Remote receptacle, the Auto Sense Remote feature automatically switches voltage/amperage control to the remote control. When a device is connected to the Remote receptacle, remote voltage/amperage control is always available regardless of the position of the Process/Contactor switch.

In Example:
Min = 20 A DC
Max = 205 A DC

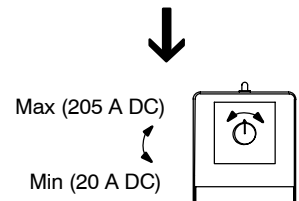
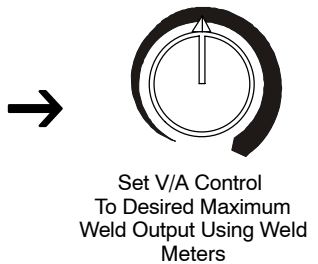
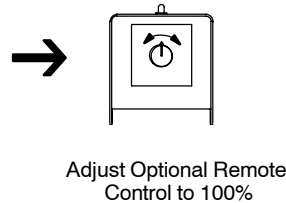
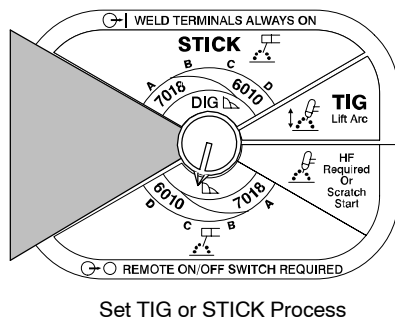
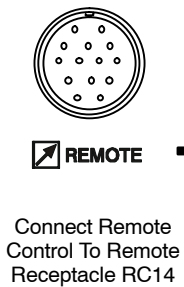







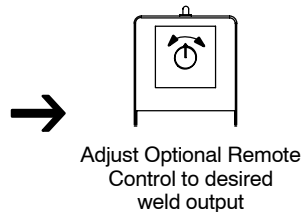
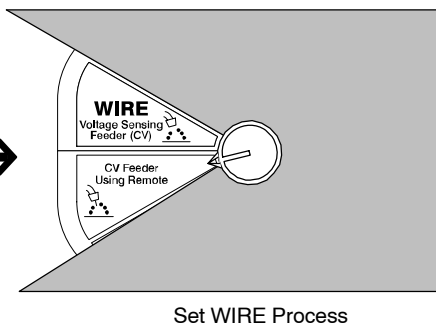
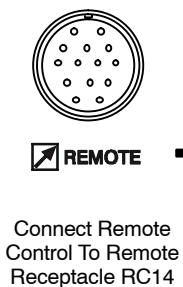

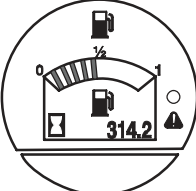

Adjust Optional Remote Control to desired weld output

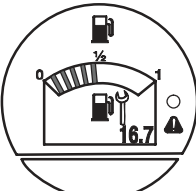
Weld meters will always show the combined main and remote control setting and machine welds at nominal output setting of the meter.

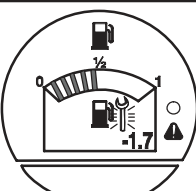
Weld meters show preset output when not welding.

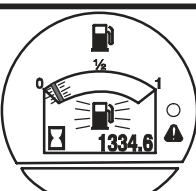
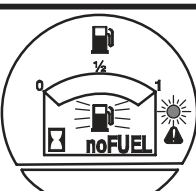
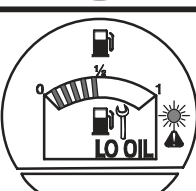

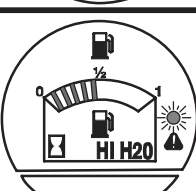
6-6. Fuel/Hour Gauge Descriptions

FUEL/HOUR GAUGE DESCRIPTIONS	
	<p>ENGINE HOURS: Gauge will display engine hours while engine is running. To display engine hours while the engine is off, place Engine Control switch in position "2".</p> 
	<p>OIL CHANGE INTERVAL: Gauge will display hours remaining before oil change is due with Engine Control switch in position "3" (with engine off).</p> 
	<p>OIL CHANGE DUE: Gauge will display blinking wrench when oil change is due (0 to -99 hours).</p> <p>To Reset: Toggle Engine Control switch between position "2" and "3" three times within 5 seconds (engine off).</p> 
	<p>LOW FUEL: Fuel level low when fuel icon and last bar in fuel gauge blink.</p> <p>To Reset: Refuel.</p>
	<p>NO FUEL: Engine shuts down before fuel runs out. Display shows "noFuel", and fuel icon and fault indicator flash.</p> <p>To Reset: Refuel.</p>
	<p>LOW OIL PRESSURE: Engine shuts down when oil pressure is low. Display shows "LO OIL", fault indicator flashes and wrench is displayed.</p> <p>To Reset: Place Engine Control switch in OFF position.</p> 
	<p>HIGH COOLANT TEMP: Engine shuts down when coolant temperature is high. Display shows "HI H2O" and fault indicator flashes.</p> <p>To Reset: Place Engine Control switch in OFF position.</p> 
<p>Note: Switch positions are numbered to illustrate that there are four switch positions. Actual graphics on front panel will vary.</p>	

SECTION 7 – OPERATING AUXILIARY EQUIPMENT

7-1. Generator Power Receptacles

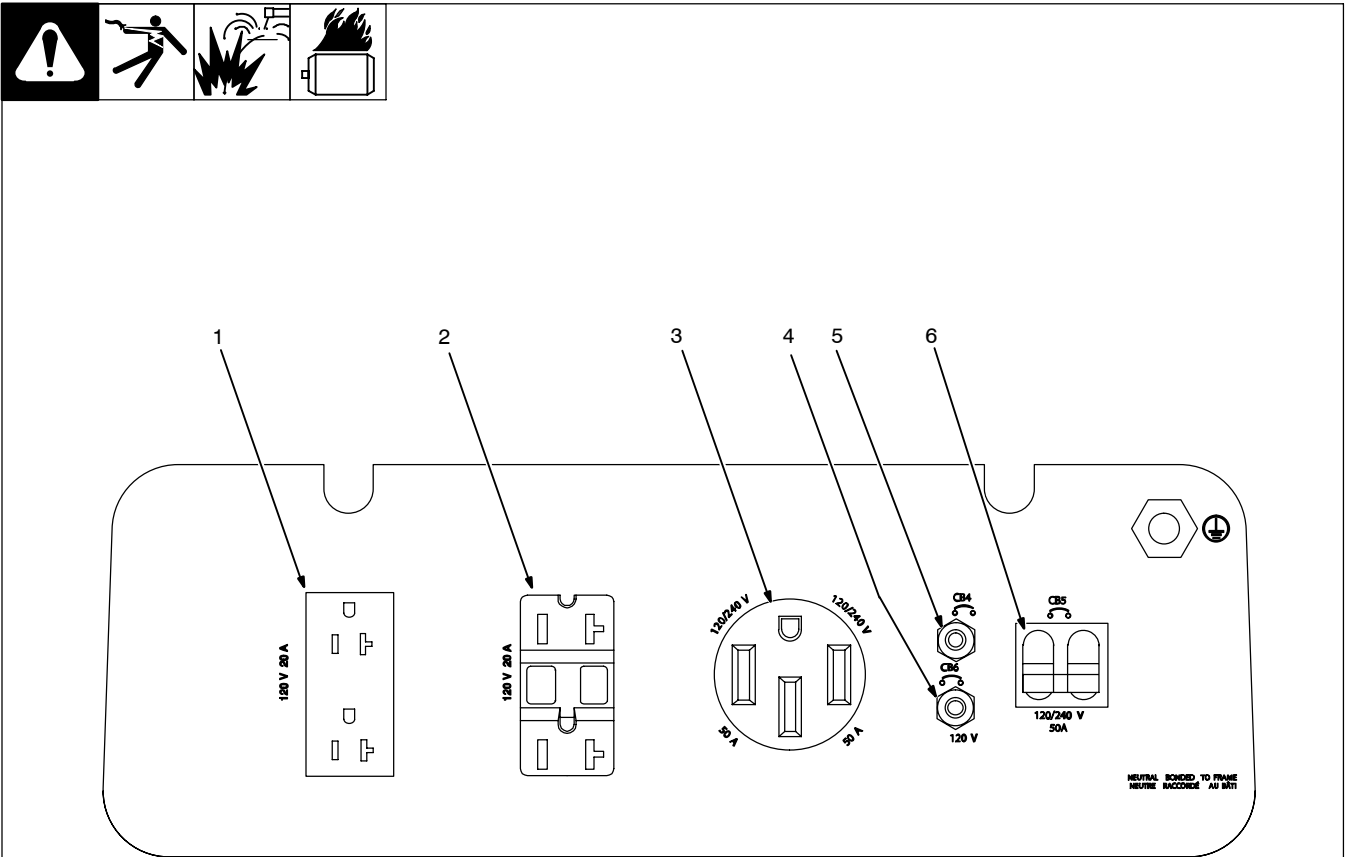

217 357-A

- 1 120 V 20 A AC (shown)
Receptacle RC5 and/or GFCI1
- 2 120 V 20 A AC GFCI (shown)
Receptacle RC6 and/or GFCI2
- 3 240 V 50 A AC
Receptacle RC11

RC5 / 6 and GFCI1 / 2 supply 60 Hz single-phase power at weld/power speed. Receptacle configuration varies depending on machine model and serial number.

Maximum output from these receptacles is 2.4 kVA/kW.

If a ground fault is detected, GFCI Reset button pops out and receptacle does not work. Check for faulty equipment plugged in receptacle. Press button to reset GFCI receptacle.

☞ *At least once a month, run engine at weld/power speed and press test button to verify GFCI is working properly.*

RC11 supplies 60 Hz single-phase power at weld/power speed. Maximum output from RC11 is 10 kVA/kW.

- 4 Supplementary Protector CB4
- 5 Supplementary Protector CB6
- 6 Supplementary Protector CB5

CB4 protects RC6 / GFCI2 and CB6 protects RC5 / GFCI1 from overload. If a supplementary protector opens, the receptacle does not work. Press button to reset.

Supplementary protector CB5 protects receptacles and the generator winding from

overload. If CB5 opens, the receptacles do not work. Place CB5 switch in On position to reset circuit breaker.

☞ *If a supplementary protector continues to open, contact Factory Authorized Service Agent.*

☞ *Generator power decreases as weld output increases.*

Combined output of all receptacles is limited to the 10 kVA/kW rating of the generator.

EXAMPLE: If 15 A is drawn from each 120 V receptacle, only 26 A is available at the 240 V receptacle:

$$2 \times (120 \text{ V} \times 15 \text{ A}) + (240 \text{ V} \times 26 \text{ A}) = 10.0 \text{ kVA/kW}$$













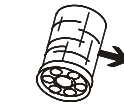
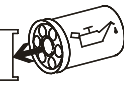
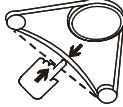

SECTION 8 – MAINTENANCE & TROUBLESHOOTING

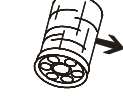
8-1. Routine Maintenance

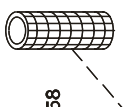
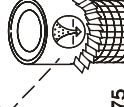
									<p>Stop engine before maintaining.</p> <p>See Engine Manual and Maintenance Label for important start-up, service, and storage information. Service engine more often if used in severe conditions.</p>
Recycle engine fluids.									

		✓ = Check ◇ = Change ● = Clean ☆ = Replace * To be done by Factory Authorized Service Agent				Reference			
Every 8 Hours		✓ Coolant Level		✓ Fuel Level		✓ Oil Level		● Oil, Fuel Spills	Section 5-8, 8-6
Every 50 Hours		● Weld Terminals							
Every 100 Hours		● Battery Terminals		✓ Air Cleaner Hoses		✓ Air Cleaner Element			Section 8-3
Every 250 Hours		☆ Unreadable Labels		✓ Fan Belt Tension <small>1/2 in. (13 mm)</small>		◇ Oil ◇ Oil Filter		✓ ● Spark Arrestor	Engine Manual, Section 8-4
Every 500 Hours		✓ ☆ Weld Cables		◇ Fuel Filter		◇ Inline Fuel Filter		✓ Radiator Thermostat	
Every 1000 Hours		✓ Radiator Fluid Level		● Inside Unit		✓ Valve Clearance*		● Drain Sludge	Section 5-8, 8-8, 8-6 and Engine Manual
		✓ ● Slip Rings* ✓ ☆ Brushes*							
Every 2000 Hours		● Injectors*							

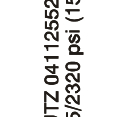
8-2. Maintenance Label

<p>DEUTZ 2008L04 (24.2 HP) DIESEL ENGINE</p>		 <p>DEUTZ 04112526</p>		 <p>12 V BCI 55 585 A @ 0° F (-18° C)</p>		 <p>1500 RPM (Optional)</p>	
<p>250 h std.</p>  <p>API: CD/CE/CF-4 7.8 qts (7.4 L)</p>  <p>MILLER 228 778 DEUTZ 04112261 BALDWIN B7099</p>  <p>MILLER 228 780 DEUTZ 04114380</p>  <p>1/2 in (13 mm)</p>		 <p>MILLER 228 780 DEUTZ 04114380</p>		 <p>2. MILLER 228 779 DEUTZ 04114220</p>		 <p>Thermostat DEUTZ 04112041 6 qts (5.7 L)</p>	
<p>500 h std.</p>  <p>In-Line Filter</p> <p>1. MILLER 213 858</p>		 <p>MILLER 197 679 Donaldson P822858</p>  <p>MILLER 197 676 Donaldson P821575</p>		 <p>8 h std.</p> <p>DIESEL 11.5 gal (43.5 L)</p> <p>DIN 51 601 BS 2869: A1, A2 ASTM D 975-81: 1-D, 2-D VV-F 800C: DF-A, DF-1, DF-2 S < = .5%</p>		 <p>100 h std.</p>	
<p>2000 h std.</p>  <p>DEUTZ 04112552 2175/2320 psi (150/160 bar)</p>		 <p>DEUTZ 04112552 2175/2320 psi (150/160 bar)</p>		 <p>DEUTZ 04112552 2175/2320 psi (150/160 bar)</p>		 <p>DEUTZ 04112552 2175/2320 psi (150/160 bar)</p>	

228246-C

8-3. Servicing Air Cleaner

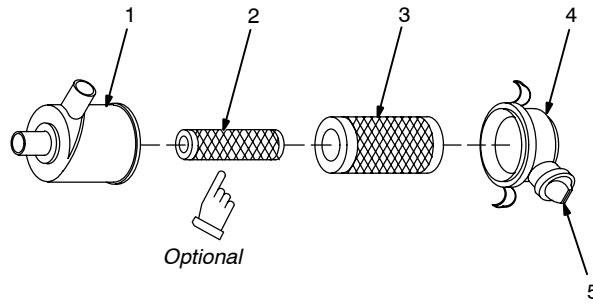
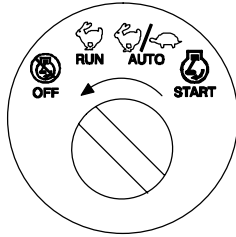

⚠ Stop engine.

NOTICE – Do not run engine without air cleaner or with dirty element. Engine damage caused by using a damaged element is not covered by the warranty.

☞ The air cleaner primary element can be cleaned but the dirt holding capacity of the filter is reduced with each cleaning. The chance of dirt reaching the clean side of the filter while cleaning and the possibility of filter damage makes cleaning a risk. Consider the risk of unwarrantable equipment damage when determining whether to clean or replace the primary element.

If you decide to clean the primary element, we strongly recommend installing an optional safety element to provide additional engine protection. **Never clean a safety element.** Replace the safety element after servicing the primary element three times.

Clean or replace primary element if dirty (see note above before cleaning). **Replace** primary element if damaged. Replace primary element yearly or after six cleanings.

- 1 Housing
- 2 Safety Element (Optional)
- 3 Primary Element
- 4 Dust Cap
- 5 Dust Ejector

To clean air filter:

Wipe off cap and housing. Remove cap and dump out dust. Remove element(s). Wipe dust from inside cap and housing with damp cloth. Reinstall safety element (if present). Reinstall cap.

NOTICE – Do not clean housing with air hose.

Clean primary element with compressed air only.

Air pressure must not exceed 100 psi (690 kPa). Use 1/8 in (3 mm) nozzle and keep nozzle at least 2 in (51 mm) from inside of element. Replace primary element if it has holes or damaged gaskets.

Reinstall primary element and cap (dust ejector down).

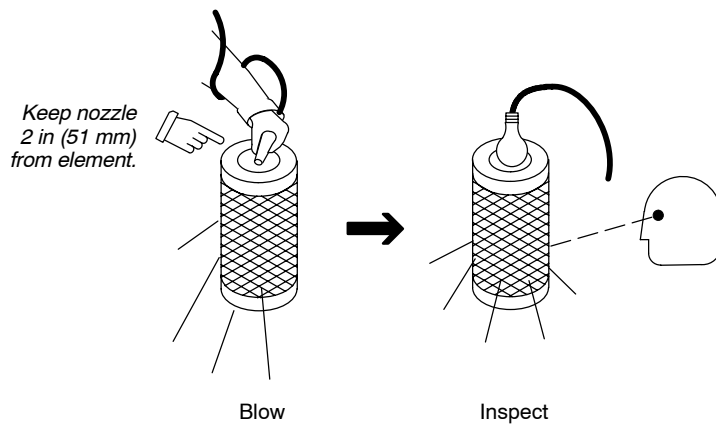

8-4. Inspecting And Cleaning Optional Spark Arrestor Muffler

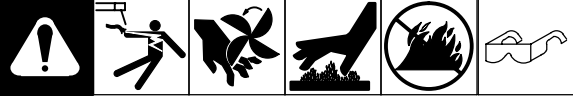

Tools Needed:
 3/8 in

⚠ Stop engine and let cool.

- Spark Arrestor Muffler
- Cleanout Plug
- Exhaust Pipe

Remove plug and remove any dirt covering cleanout hole.

- Exhaust Pipe

Start engine and run at idle speed to blow out cleanout hole. If nothing blows out of hole, briefly cover end of exhaust pipe with fireproof material.

⚠ Stop engine and let cool.

Reinstall cleanout plug.

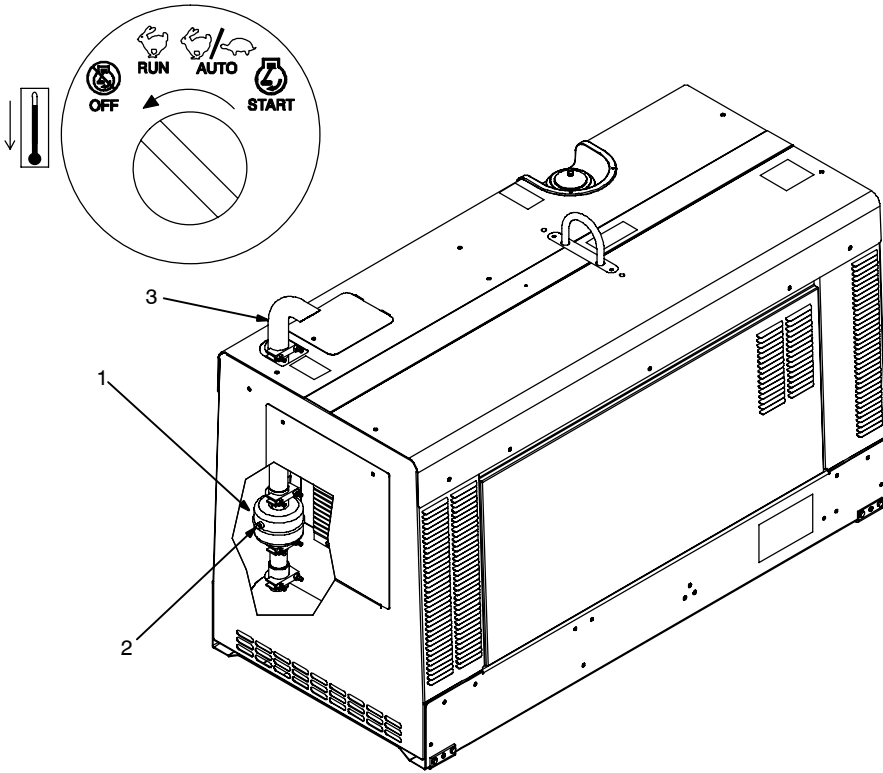

803 582 / Ref. 214 778-B

8-5. Servicing Engine Cooling System



⚠ Stop engine and let cool.

- Radiator Draincock
- Radiator Cap Cover

Change coolant according to engine manual. Add coolant according to Section 5-8).

Run engine until engine reaches normal operating temperature. Check coolant level in recovery tank. Add coolant if necessary.

After engine cools, check coolant level again and add coolant if necessary.

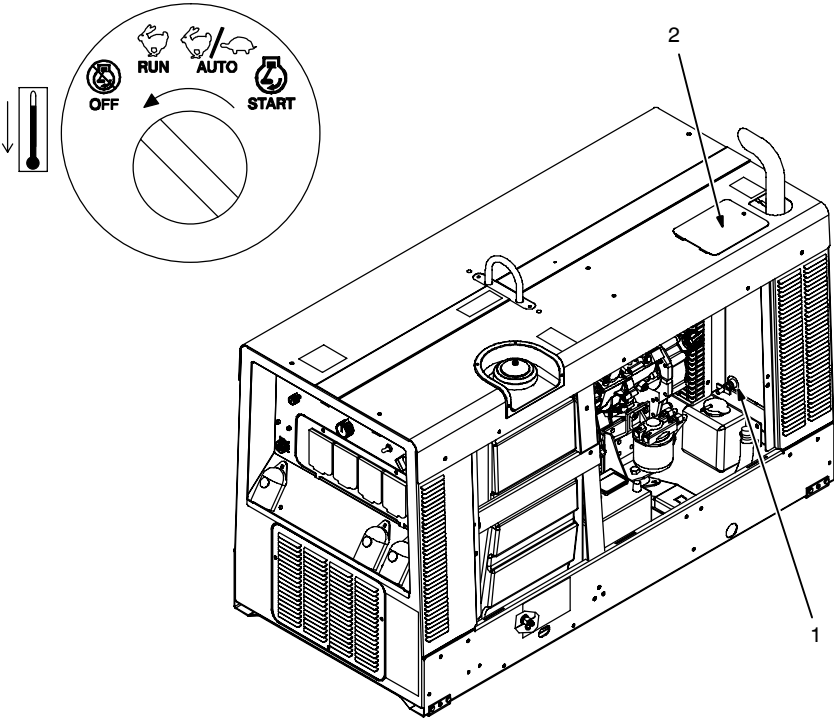

805 177-A

8-6. Servicing Fuel And Lubrication Systems

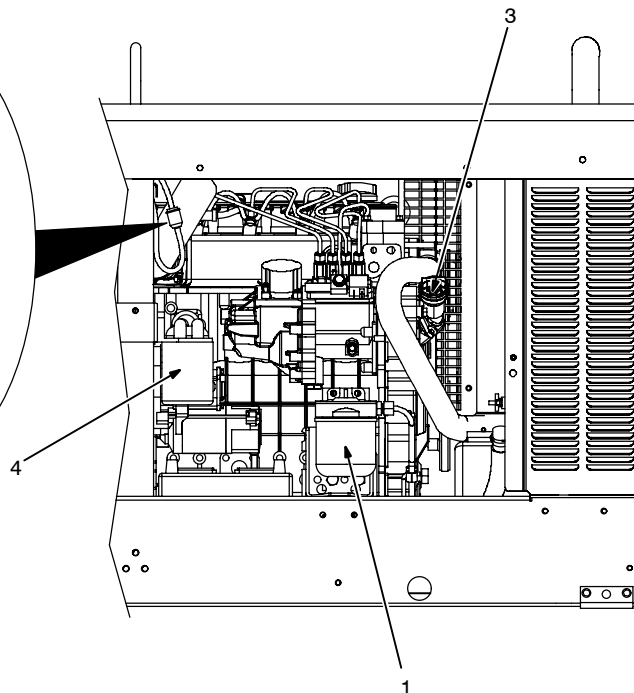
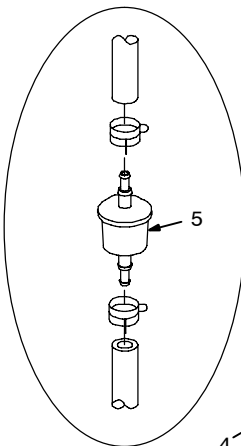
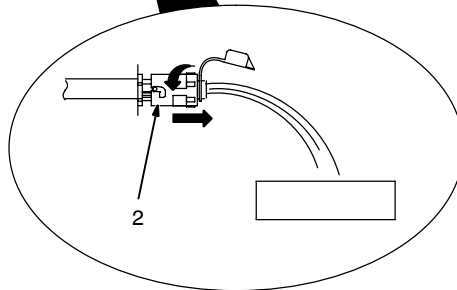
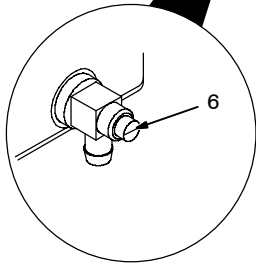
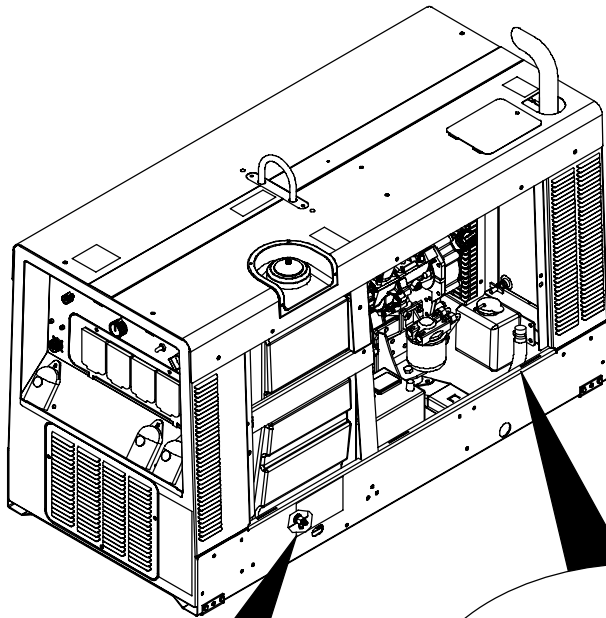
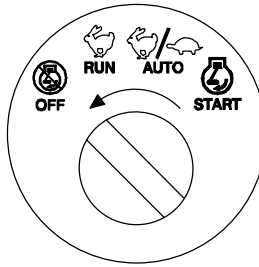
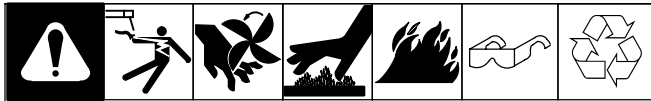

⚠ Stop engine and let cool.

⚠ After servicing, start engine and check for fuel leaks. Stop engine, tighten connections as necessary, and wipe up spilled fuel.

- 1 Oil Filter
- 2 Oil Drain Valve And Hose
- 3 Oil Fill Cap
- 4 Primary (Canister) Fuel Filter
- 5 Secondary (In-Line) Fuel Filter
- 6 Fuel Tank Sludge Drain Valve

To change oil and filter:

Route oil drain hose and valve through hole in base. See engine manual and engine maintenance label for oil/filter change information.

To replace primary (canister) fuel filter:

Turn filter counterclockwise. Remove filter.

Fill new filter with fresh fuel. Apply thin coat of fuel to gasket on new filter. Install new filter and turn clockwise.

Inspect fuel lines, and replace if cracked or worn.

To drain water from fuel system:

See engine manual.

To replace secondary (in-line) fuel filter:

Note direction of fuel flow as indicated by arrow on side of filter. Remove fuel line clamps and disconnect fuel lines from fuel filter. Replace filter, reconnect fuel lines, and reinstall clamps.

To drain sludge from fuel tank:

⚠ Beware of fire. Do not smoke and keep sparks and flames away from drained fuel. Dispose of drained fuel in an environmentally-safe manner. Do not leave unit unattended while draining fuel tank.

⚠ Properly lift unit and secure in a level position. Use adequate blocks or stands to support unit while draining fuel tank.

Attach 1/2 ID hose to drain valve. Put metal container under drain, and use screwdriver to open sludge drain valve. Close valve when sludge has drained. Remove hose.

Close door.

Tools Needed:

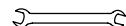

8-7. Overload Protection

⚠ Stop engine.

☞ *When a circuit breaker, supplementary protector, or fuse opens, it usually indicates a more serious problem exists. Contact Factory Authorized Service Agent.*

- 1 Fuse F1
- 2 Circuit Breaker CB1 (Not Shown)
- 3 Supplementary Protector CB2
- 4 Supplementary Protector CB3
- 5 Supplementary Protector CB7
- 6 Supplementary Protector CB8

CB1 protects the engine battery circuit. If CB1 opens, the engine will not crank. CB1 automatically resets when the fault is corrected.

CB2 protects the engine wiring harness. If CB2 opens, the engine will not crank.

CB3 protects part of the weld control wiring harness. If CB3 opens, weld and generator power output stops.

CB7 protects the 115 volt ac output to remote receptacle RC14. If CB7 opens, 115 volt output to RC14 stops.

CB8 protects the 24 volt ac output to remote receptacle RC14. If CB8 opens, 24 volt output to RC14 stops.

Press button to reset supplementary protector.

803 562 / 803 566

8-8. Checking Generator Brushes



⚠ Stop engine and let cool.

1 Generator Brush With Spring

Mark and disconnect leads at brush holder cap. Remove brushes.

Replace brushes if damaged or if brush material is at or near minimum length.

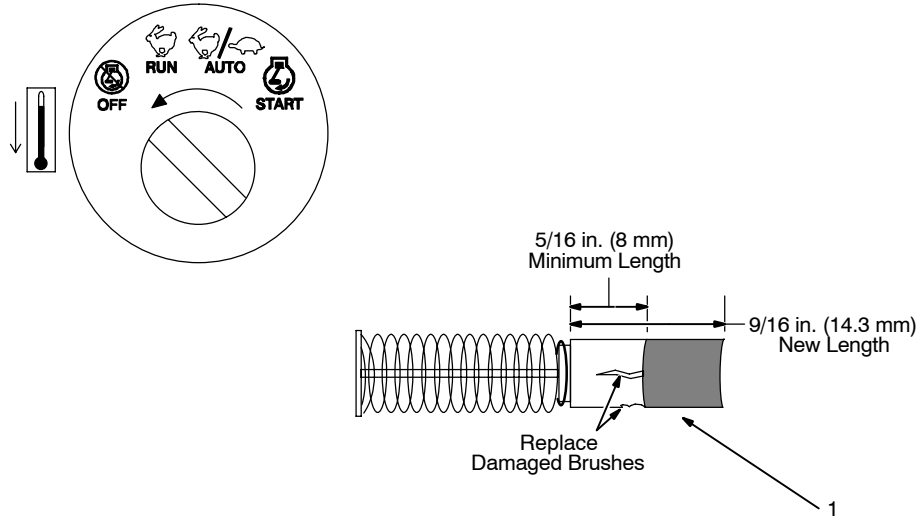











Ref 2114 778-D / S-0233-A

8-9. Adjusting Engine Speed

NOTICE – Engine speed adjustment must be done by an engine Factory Authorized Service Agent. Tampering with adjustments may affect engine warranty.

Notes

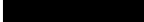
MATERIAL THICKNESS REFERENCE CHART

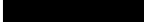
	24 Gauge (.025 in)
	22 Gauge (.031 in)
	20 Gauge (.037 in)
	18 Gauge (.050 in)
	16 Gauge (.063 in)
	14 Gauge (.078 in)
	1/8 in (.125 in)
	3/16 in (.188 in)
	1/4 in (.25 in)
	5/16 in (.313 in)
	3/8 in (.375 in)
	1/2 in (.5 in)

8-10. Voltmeter/Ammeter Help Displays

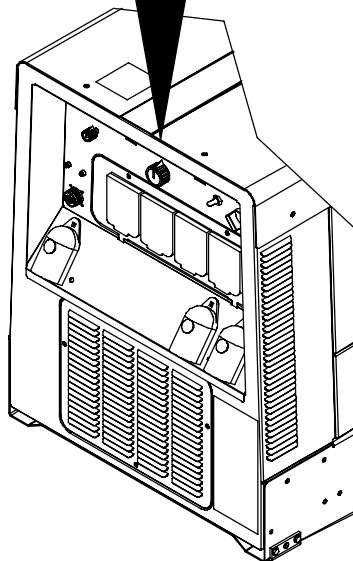
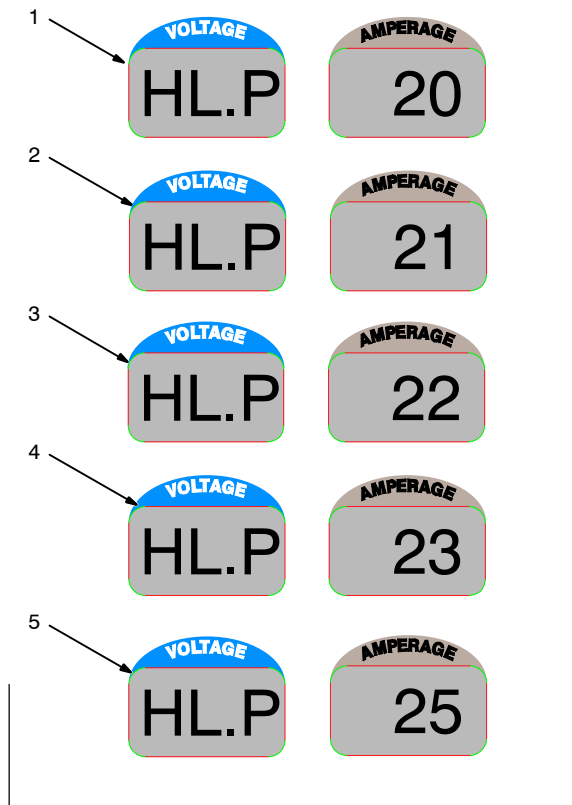

Use the Voltmeter/Ammeter help displays to diagnose and correct fault conditions.

☞ When a help code is displayed normally weld output has stopped but generator power output may be okay.

☞ To reset help displays, stop unit and then restart. See item 6 below to reset Help 25 display.

1 Help 20 Display

Indicates a failure of meter display module PC2, or the wiring between PC2 and main control module PC1. If this display is shown, have Factory Authorized Service Agent check PC1, PC2, and the wiring between PC1 and PC2.

2 Help 21 Display

Indicates thermistor TH1 on the main rectifier heat sink has failed. If this display is shown, have Factory Authorized Service Agent check TH1, and the wiring between TH1 and PC1.

3 Help 22 Display

Indicates the rectifier heat sink has overheated. If this display is shown, check generator cooling system and/or reduce duty cycle. Keep engine access door closed when running to maintain proper cooling air flow past rectifier. Allow unit to cool before restarting. If problem continues, have Factory Authorized Service Agent check unit.

4 Help 23 Display

Can indicate a complete loss of generator excitation, auxiliary power output, and weld output or a failure of one of the rectifier output SRCs. If generator output is lost, see trouble "No generator power or weld output." in section 8-11B. If generator output is okay, have Factory Authorized Service Agent check the rectifier SCRs.

5 Help 25 Display

Indicates a remote device connected to Remote Receptacle RC14 may be faulty. Help 25 is also displayed whenever a remote device has been connected to RC14 and then disconnected. Clear fault by stopping and restarting the unit or by turning Process/Contactor switch to another position. If problem continues, have Factory Authorized Service Agent check the remote device, filter board PC6, and main control module PC1.

8-11. Troubleshooting

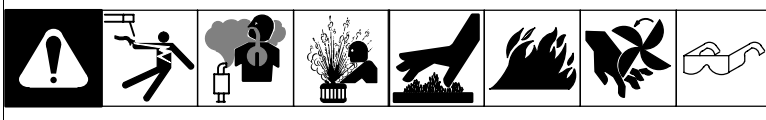

☞ Also see Voltmeter/Ammeter help displays to assist in troubleshooting weld problems (see Section 8-10).

A. Welding

Trouble	Remedy
No weld output; generator power output okay at ac receptacles.	Place Process/Contactor switch in a Weld Terminals Always On position, or place switch in a Remote On/Off Switch Required position and turn remote contactor on (see Section 5-11).
	Reset supplementary protector CB7 or CB8 (see Section 8-7). Check for faulty remote device connected to RC14.
	Check and secure connections to Remote Control receptacle RC14 (see Section 5-11).
	Check Voltmeter/Ammeter help displays (see Section 8-10).
No weld output, or generator power output at ac receptacles.	Disconnect equipment from generator power receptacles during start-up.
	Reset supplementary protector CB3. (see Section 8-7).
	Check fuse F1, and replace if open (see Section 8-7). If F1 is open, have Factory Authorized Service Agent check the field excitation circuit.
	Check Voltmeter/Ammeter help displays (see Section 8-10).
	Have Factory Authorized Service Agent check brushes and slip rings and field excitation circuit.
Erratic weld output.	Check and tighten connections inside and outside unit.
	Be sure connection to work piece is clean and tight.
	Use dry, properly stored electrodes.
	Remove excessive coils from weld cables.
	Have Factory Authorized Service Agent check brushes and slip rings.
High weld output.	Have Factory Authorized Service Agent check main control module PC1 and hall device HD1.
Low weld output.	Check engine speed, and have engine Factory Authorized Service Agent adjust if necessary.
	Check fuse F1, and replace if open (see Section 8-7). If F1 is open, have Factory Authorized Service Agent check the rotor.
Low open-circuit voltage.	Check engine speed, and have engine Factory Authorized Service Agent adjust if necessary.
	Have Factory Authorized Service Agent check main control module PC1, field excitation circuit, and main rectifier.
No remote fine amperage control.	Repair or replace remote control device.
	Check and secure connections to Remote Amperage Adjust receptacle RC14 (see Section 5-11).
No 24 volt or 115 volt ac output at Remote receptacle RC14.	Reset supplementary protector CB7 (24 volt) or CB8 (115 volt) (see Section 8-7).

B. Generator Power

Trouble	Remedy
No generator power output at ac receptacles; weld output okay.	Reset receptacle supplementary protector(s) (see Section 7-1).
No generator power or weld output.	Disconnect equipment from generator power receptacles during start-up.
	Check fuse F1, and replace if open (see Section 8-7). Have Factory Authorized Service Agent check field excitation circuit.
	Reset supplementary protector CB3 (see Section 8-7).
	Check Voltmeter/Ammeter help displays (see Section 8-10).
	Have Factory Authorized Service Agent check brushes and slip rings, and field excitation circuit.
High output at generator power ac receptacles.	Have Factory Authorized Service Agent check field excitation circuit.
Low output at generator power ac receptacles.	Check engine speed, and have engine Factory Authorized Service Agent adjust if necessary.
	Check fuse F1, and replace if open (see Section 8-7). If F1 is open, have Factory Authorized Service Agent check the rotor.

C. Engine

Trouble	Remedy
Engine will not crank.	Check battery, and replace if necessary.
	Check battery connections and tighten if necessary.
	Circuit breaker CB1 may be open. CB1 automatically resets when fault is corrected (see Section 8-7). Have Factory Authorized Service Agent check engine wiring harness and components.
	Reset supplementary protector CB2 (see Section 8-7).
	Check engine wiring harness plug connections.
	Have Factory Authorized Service Agent check Engine Control switch S1, and control relay CR2.
Engine cranks but does not start.	Check fuel level.
	Check battery and replace if necessary. Check engine charging system according to engine manual.
	Have Factory Authorized Service Agent check control relay CR1, fuel solenoid FS1, and the fuel pump.
	Air in fuel system. See engine manual.
Engine hard to start in cold weather.	Use Preheat switch (see Section 6-1).
	Keep battery in good condition. Store battery in warm area off cold surface.
	Use fuel formulated for cold weather (diesel fuel can gel in cold weather). Contact local fuel supplier for fuel information.
	Use correct grade oil for cold weather (see Section 8-2).
	Have Factory Authorized Service Agent check Preheat switch S4, control relay CR3, and the glow plug.
Engine suddenly stops.	Check oil and coolant levels. Automatic shutdown system stops engine if oil pressure is too low or coolant temperature is too high (see Section 5-8).
	Circuit breaker CB1 may be open. CB1 automatically resets when fault is corrected (see Section 8-7). Reset supplementary protector CB2 (see Section 8-7). Have Factory Authorized Service Agent check engine alternator, engine harness, fuel valve, and the fuel pump.
	Have Factory Authorized Service Agent check Engine Control switch S1, control relay CR1, integrated rectifier SR2, fuel valve, and the fuel pump.
	See engine manual.

Trouble	Remedy
Engine slowly stopped and cannot be restarted.	Check fuel level.
	Check engine air and fuel filters (see Sections 8-3 and 8-6).
	See engine manual.
Battery discharges between uses.	Turn Engine Control switch off when unit is not running.
	Clean top of battery with baking soda and water solution; rinse with clear water.
	Recharge or replace battery if necessary.
	Periodically recharge battery (approximately every 3 months).
Engine idles, but does not come up to weld speed (units with idle option only).	Have Factory Authorized Service Agent check fuel/hour gauge and current transformer CT1.
Engine does not run at idle speed (units with idle option only).	Have Factory Authorized Service Agent check fuel/hour gauge, and control relay CR4.
Engine uses oil during run-in period; wetstacking occurs.	Dry engine according to run-in procedure (see Section 10).

Notes

SECTION 9 - ELECTRICAL DIAGRAMS

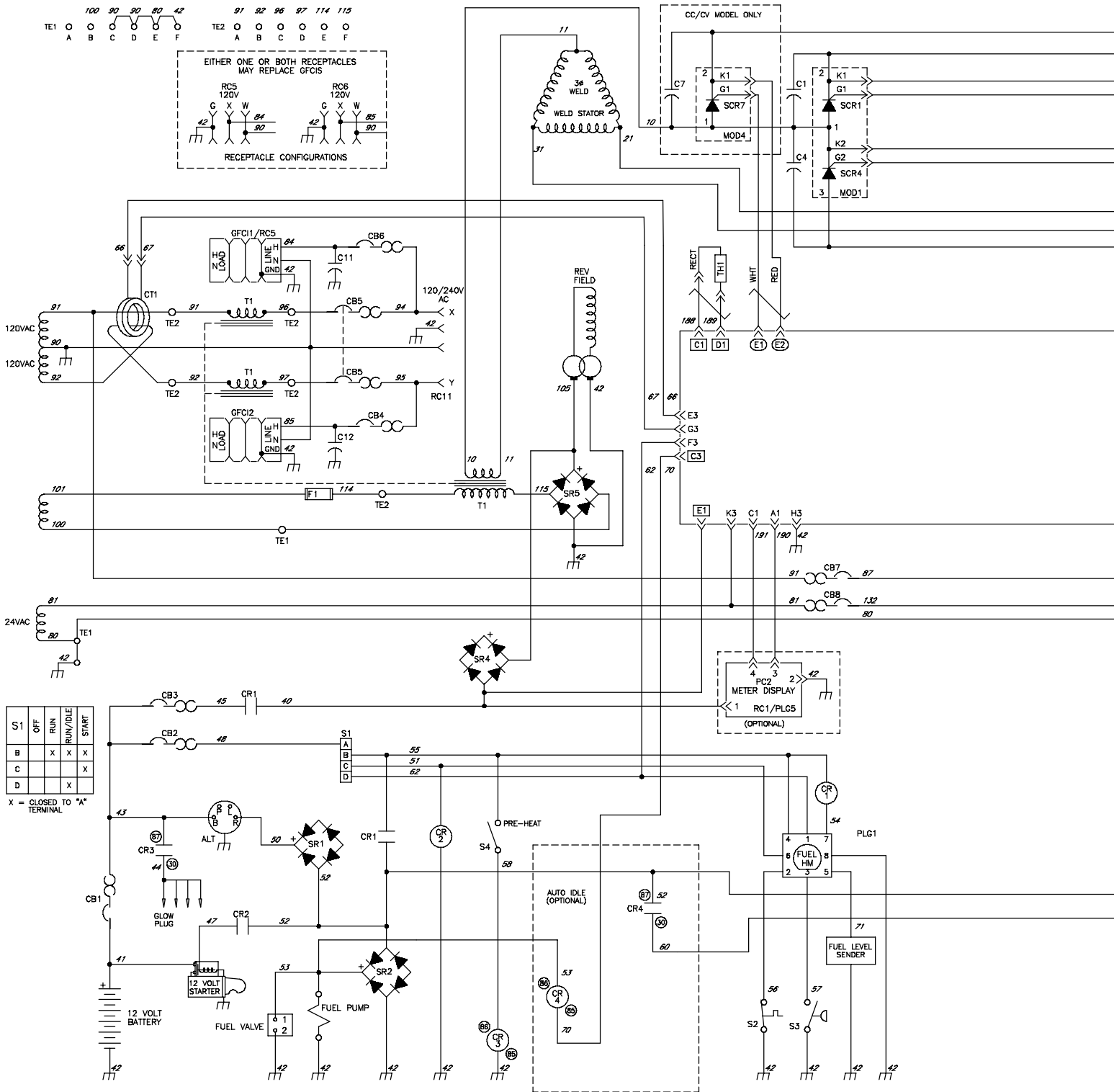

Figure 9-1. Circuit Diagram For Welding Generator

⚠ WARNING



ELECTRIC SHOCK HAZARD

- Do not touch live electrical parts.
- Disconnect input power or stop engine before servicing.
- Do not operate with covers removed.
- Have only qualified persons install, use, or service this unit.

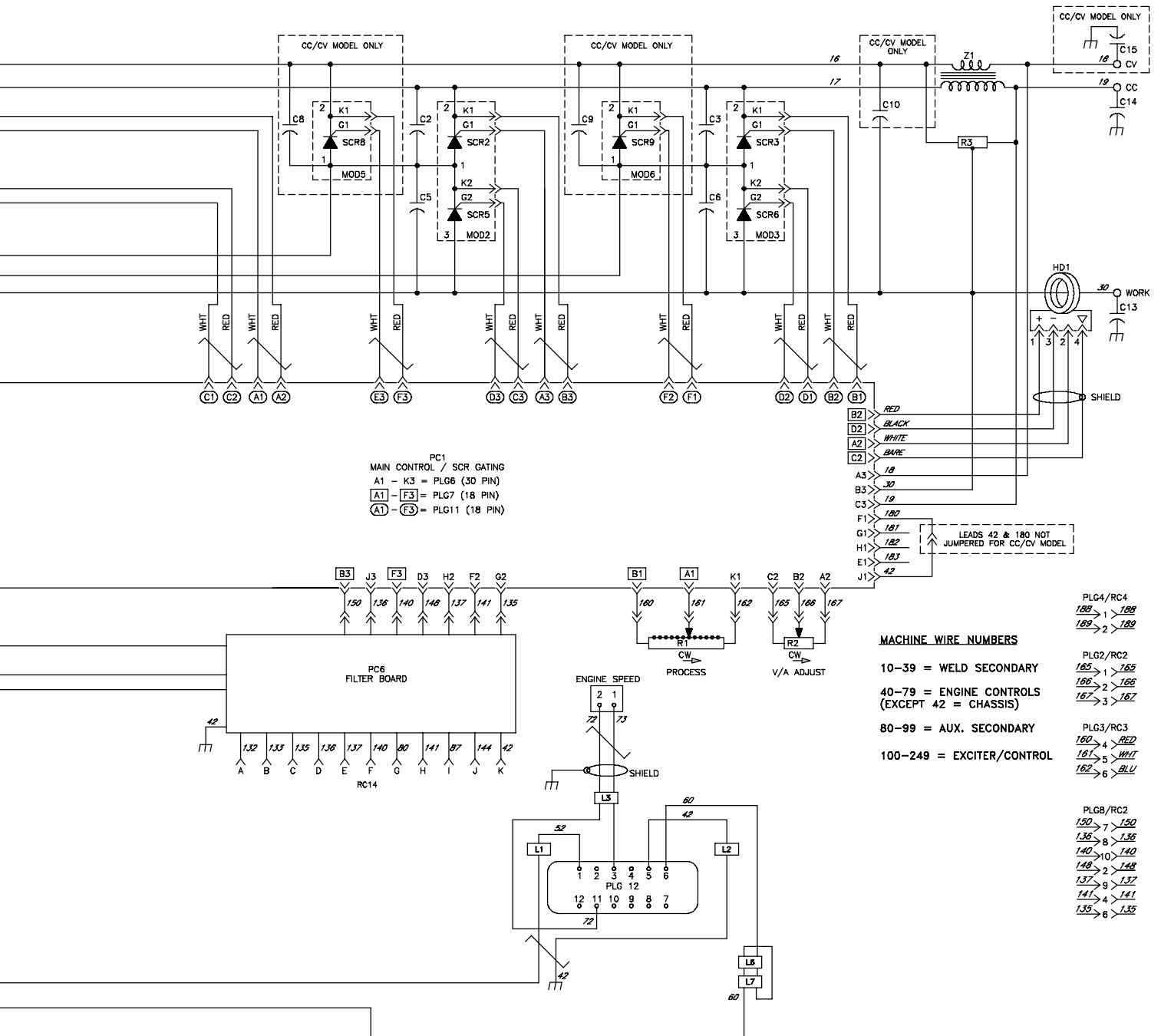

SECTION 10 – RUN-IN PROCEDURE

run_in1 2007-04

10-1. Wetstacking

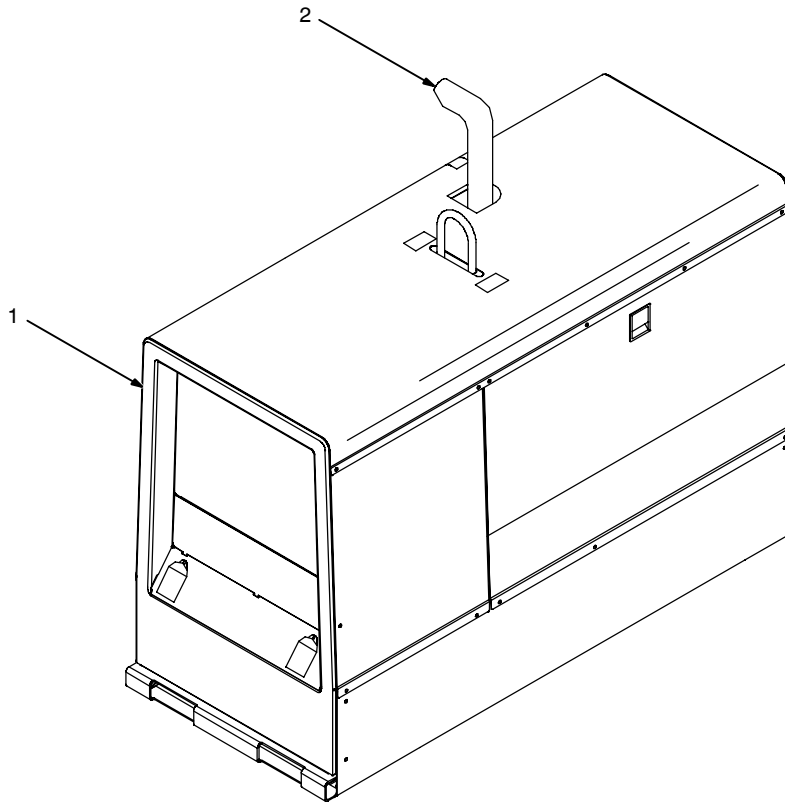

NOTICE – Do not perform run-in procedure at less than 20 volts weld output and do not exceed duty cycle or equipment damage may occur.

1 Welding Generator

Run diesel engines near rated voltage and current during run-in period to properly seat piston rings and prevent wetstacking. See nameplate, rating label, or specifications section in this manual to find rated voltage and current.

NOTICE – Do not idle engine longer than necessary. Piston rings seat faster if engine runs at weld/power rpm, and the welding generator is kept loaded during run-in.

2 Engine Exhaust Pipe



Wetstacking is unburned fuel and oil in the exhaust pipe and occurs during run-in if the engine is run too long at light load or idle rpm.

If exhaust pipe is coated with a wet, black, tar-like substance, dry the engine using one of the following run-in procedures.

See the engine manual for additional engine run-in information.

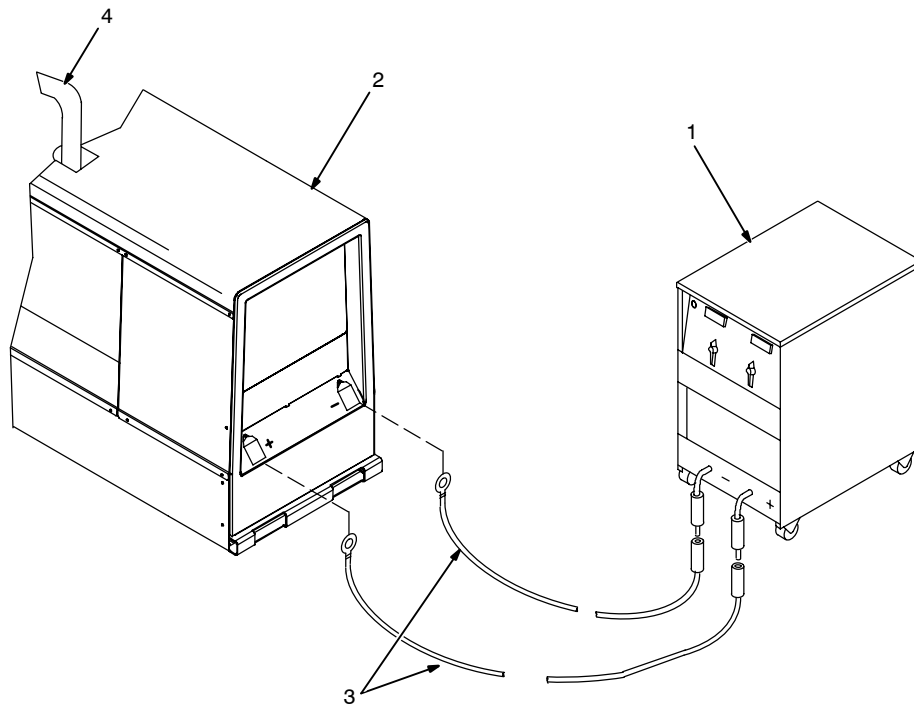
10-2. Run-In Procedure Using Load Bank



-  **Stop engine.**
-  **Do not touch hot exhaust pipe, engine parts, or load bank/grid.**
-  **Keep exhaust and pipe away from flammables.**

NOTICE – Do not perform run-in procedure at less than 20 volts weld output and do not exceed duty cycle or equipment damage may occur.

1 Load Bank

Turn all load bank switches Off. If needed, connect load bank to 115 volts ac wall receptacle or generator auxiliary power receptacle.

2 Welding Generator

Place A/V range switch in maximum position, A/V control in minimum position, and Output Selector switch (if present) in either DC position.

3 Weld Cables

Connect load bank to generator weld output terminals using proper size weld cables with correct connectors. Observe correct polarity.

Start engine and run for several minutes.

Set load bank switches and then adjust generator A/V control so load equals rated voltage and current of generator (see nameplate, rating label, or the specifications section in this manual).

Check generator and load bank meters after first five minutes then every fifteen minutes to be sure generator is loaded properly.

NOTICE – Check oil level frequently during run-in; add oil if needed.

It is recommended to run the welding generator for two hours minimum and up to four hours under load. Place A/V control in minimum position, then turn off load bank to remove load. Run engine several minutes at no load.

-  **Stop engine and let cool.**

4 Engine Exhaust Pipe

Repeat procedure if wetstacking is present.

10-3. Run-In Procedure Using Resistance Grid

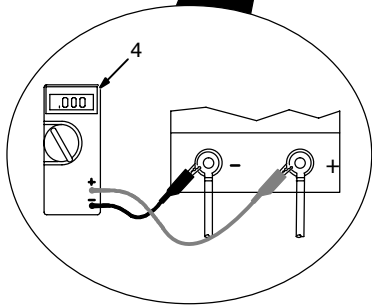
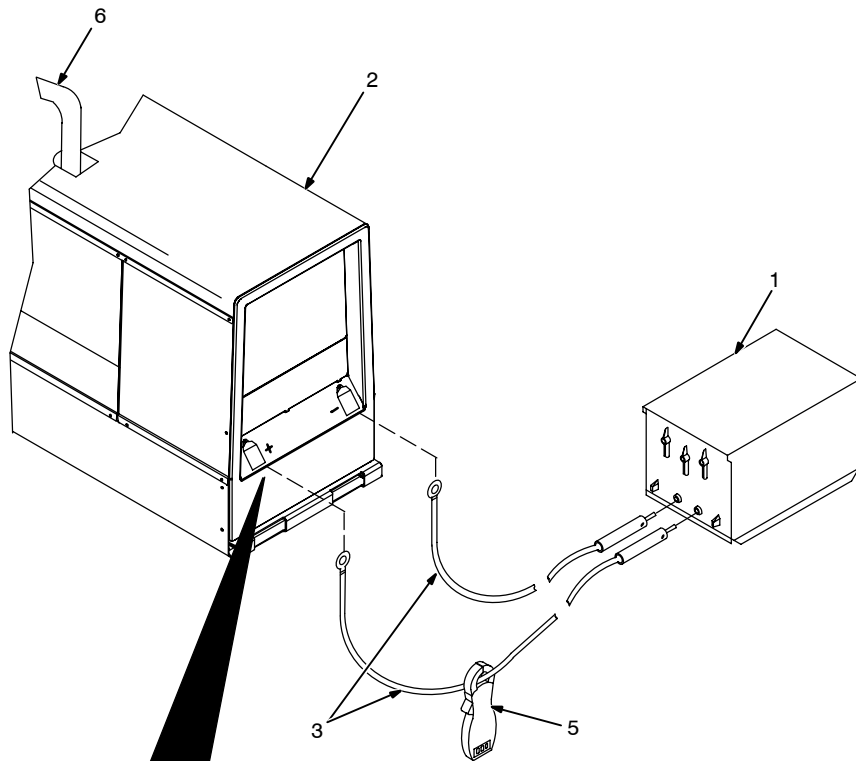

- Stop engine.**
- Do not touch hot exhaust pipe, engine parts, or load bank/grid.**
- Keep exhaust and pipe away from flammables.**

NOTICE – Do not perform run-in procedure at less than 20 volts weld output and do not exceed duty cycle or equipment damage may occur.

1 Resistance Grid

Use grid sized for generator rated output.

Turn Off grid.

2 Welding Generator

Place A/V range switch in maximum position, A/V control in minimum position, and Output Selector switch (if present) in either DC position.

3 Weld Cables

Connect grid to generator weld output terminals using proper size weld cables with correct connectors (polarity is not important).

4 Voltmeter

5 Clamp-On Ammeter

Connect voltmeter and ammeter as shown, if not provided on generator.

Start engine and run for several minutes.

Set grid switches and then adjust generator A/V control so load equals rated voltage and current of the generator (see nameplate, rating label, or the specifications section in this manual).

Check generator and meters after first five minutes then every fifteen minutes to be sure generator is loaded properly.

NOTICE – Check oil level frequently during run-in; add oil if needed.

It is recommended to run the welding generator for two hours minimum and up to four hours under load. Place A/V control in minimum position, then shut down grid to remove load. Run engine several minutes at no load.

- Stop engine and let cool.**



6 Engine Exhaust Pipe

Repeat procedure if wetstacking is present.

SECTION 11 – GENERATOR POWER GUIDELINES

 The views in this section are intended to be representative of all engine-driven welding generators. Your unit may differ from those shown.

11-1. Selecting Equipment



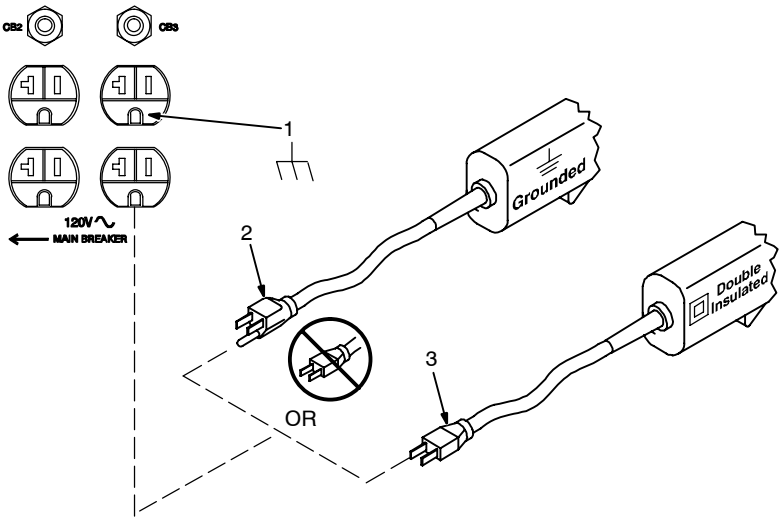

- 1 Generator Power Receptacles – Neutral Bonded To Frame
- 2 3-Prong Plug From Case Grounded Equipment
- 3 2-Prong Plug From Double Insulated Equipment

 Be sure equipment has double insulated symbol and/or wording on it.

 **Do not use 2-prong plug unless equipment is double insulated.**

gen_pwr 2008-01 – ST-800 577

11-2. Grounding Generator To Truck Or Trailer Frame



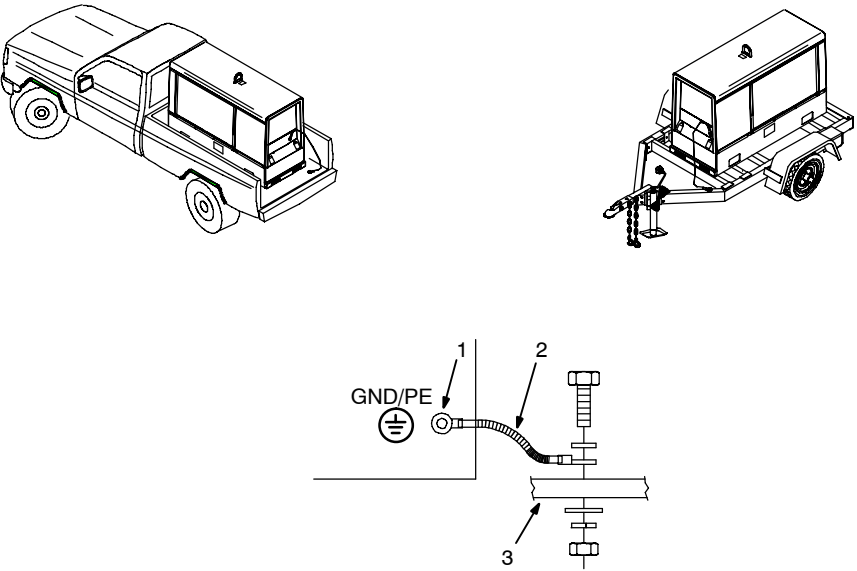

 **Always ground generator frame to vehicle frame to prevent electric shock and static electricity hazards.**

 **Also see AWS Safety & Health Fact Sheet No. 29, Grounding of Portable And Vehicle Mounted Welding Generators.**

- 1 Equipment Grounding Terminal (On Front Panel)
- 2 Grounding Cable (Not Supplied)
- 3 Metal Vehicle Frame

Connect cable from equipment ground terminal to metal vehicle frame. Use #10 AWG or larger insulated copper wire.

 Electrically bond generator frame to vehicle frame by metal-to-metal contact.

 **Bed liners, shipping skids, and some running gear insulate the welding generator from the vehicle frame. Always connect a ground wire from the generator equipment grounding terminal to bare metal on the vehicle frame as shown.**

 **If unit does not have GFCI receptacles, use GFCI-protected extension cord.**

800 652-D

11-3. Grounding When Supplying Building Systems

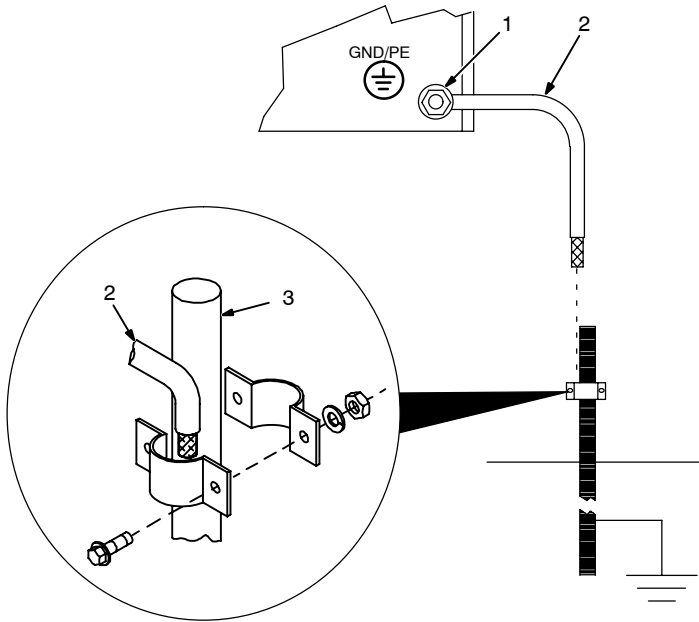

1 Equipment Grounding Terminal

2 Grounding Cable

Use #10 AWG or larger insulated copper wire.

3 Ground Device

Use ground device as stated in electrical codes.

Ground generator to system earth ground if supplying power to a premises (home, shop, farm) wiring system.

Also see AWS Safety & Health Fact Sheet No. 29, Grounding of Portable And Vehicle Mounted Welding Generators.

ST-800 576-B

11-4. How Much Power Does Equipment Require?

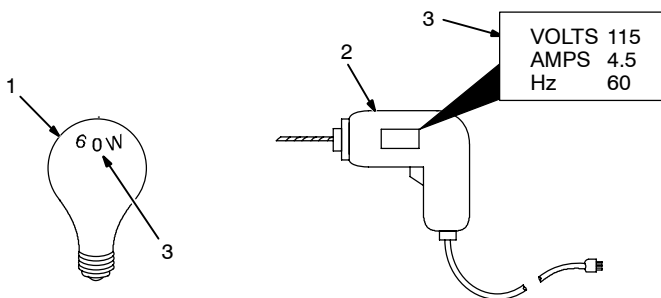

1 Resistive Load

A light bulb is a resistive load and requires a constant amount of power.

2 Non-Resistive Load

Equipment with a motor is a non-resistive load and requires approximately six times more power while starting the motor than when running (see Section 11-8).

3 Rating Data

Rating shows volts and amperes, or watts required to run equipment.

Amperes x Volts = Watts

Example 1: If a drill uses 4.5 amperes at 115 volts, calculate its running power requirement in watts.

$$4.5 \text{ A} \times 115 \text{ V} = 520 \text{ W}$$

The load applied by the drill is 520 watts.

Example 2: If three 200 watt flood lamps are used with the drill from Example 1, add the individual loads to calculate total load.

$$(3 \times 200\text{W}) + 520 \text{ W} = 1120 \text{ W}$$

The total load applied by the three flood lamps and drill is 1120 watts.

S-0623

11-5. Approximate Power Requirements For Industrial Motors

Industrial Motors	Rating	Starting Watts	Running Watts
Split Phase	1/8 HP	800	300
	1/6 HP	1225	500
	1/4 HP	1600	600
	1/3 HP	2100	700
	1/2 HP	3175	875
Capacitor Start-Induction Run	1/3 HP	2020	720
	1/2 HP	3075	975
	3/4 HP	4500	1400
	1 HP	6100	1600
	1-1/2 HP	8200	2200
	2 HP	10550	2850
	3 HP	15900	3900
Capacitor Start-Capacitor Run	5 HP	23300	6800
	1-1/2 HP	8100	2000
	5 HP	23300	6000
	7-1/2 HP	35000	8000
Fan Duty	10 HP	46700	10700
	1/8 HP	1000	400
	1/6 HP	1400	550
	1/4 HP	1850	650
	1/3 HP	2400	800
	1/2 HP	3500	1100

11-6. Approximate Power Requirements For Farm/Home Equipment

Farm/Home Equipment	Rating	Starting Watts	Running Watts
Stock Tank De-Icer		1000	1000
Grain Cleaner	1/4 HP	1650	650
Portable Conveyor	1/2 HP	3400	1000
Grain Elevator	3/4 HP	4400	1400
Milk Cooler		2900	1100
Milker (Vacuum Pump)	2 HP	10500	2800
FARM DUTY MOTORS	1/3 HP	1720	720
Std. (e.g. Conveyors,	1/2 HP	2575	975
Feed Augers, Air	3/4 HP	4500	1400
Compressors)	1 HP	6100	1600
	1-1/2 HP	8200	2200
	2 HP	10550	2850
	3 HP	15900	3900
	5 HP	23300	6800
High Torque (e.g. Barn	1-1/2 HP	8100	2000
Cleaners, Silo Unloaders,	5 HP	23300	6000
Silo Hoists, Bunk Feeders)	7-1/2 HP	35000	8000
	10 HP	46700	10700
3-1/2 cu. ft. Mixer	1/2 HP	3300	1000
High Pressure 1.8 Gal/Min	500 PSI	3150	950
Washer 2 gal/min	550 PSI	4500	1400
2 gal/min	700 PSI	6100	1600
Refrigerator or Freezer		3100	800
Shallow Well Pump	1/3 HP	2150	750
	1/2 HP	3100	1000
Sump Pump	1/3 HP	2100	800
	1/2 HP	3200	1050

11-7. Approximate Power Requirements For Contractor Equipment

Contractor	Rating	Starting Watts	Running Watts
Hand Drill	1/4 in	350	350
	3/8 in	400	400
	1/2 in	600	600
Circular Saw	6-1/2 in	500	500
	7-1/4 in	900	900
	8-1/4 in	1400	1400
Table Saw	9 in	4500	1500
	10 in	6300	1800
Band Saw	14 in	2500	1100
Bench Grinder	6 in	1720	720
	8 in	3900	1400
	10 in	5200	1600
Air Compressor	1/2 HP	3000	1000
	1 HP	6000	1500
	1-1/2 HP	8200	2200
	2 HP	10500	2800
Electric Chain Saw	1-1/2 HP, 12 in	1100	1100
	2 HP, 14 in	1100	1100
Electric Trimmer	Standard 9 in	350	350
	Heavy Duty 12 in	500	500
Electric Cultivator	1/3 HP	2100	700
Elec. Hedge Trimmer	18 in	400	400
Flood Lights	HID	125	100
	Metal Halide	313	250
	Mercury	1000	
	Sodium Vapor	1400	1000
Submersible Pump	400 gph	600	200
Centrifugal Pump	900 gph	900	500
Floor Polisher	3/4 HP, 16 in	4500	1400
	1 HP, 20 in	6100	1600
High Pressure Washer	1/2 HP	3150	950
	3/4 HP	4500	1400
	1 HP	6100	1600
55 gal Drum Mixer	1/4 HP	1900	700
Wet & Dry Vac	1.7 HP	900	900
	2-1/2 HP	1300	1300

11-8. Power Required To Start Motor

Single-Phase Induction Motor Starting Requirements								
Motor Start Code	G	H	J	K	L	M	N	P
KVA/HP	6.3	7.1	8.0	9.0	10.0	11.2	12.5	14.0



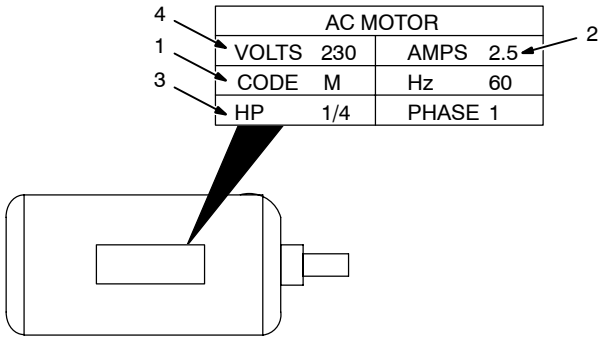

AC MOTOR			
VOLTS	230	AMPS	2.5
CODE	M	Hz	60
HP	1/4	PHASE	1

- 1 Motor Start Code
- 2 Running Amperage
- 3 Motor HP
- 4 Motor Voltage

To find starting amperage:

Step 1: Find code and use table to find kVA/HP. If code is not listed, multiply running amperage by six to find starting amperage.

Step 2: Find Motor HP and Volts.

Step 3: Determine starting amperage (see example).

Welding generator amperage output must be at least twice the motor's running amperage.

(kVA/HP x HP x 1000) / Volts = Starting Amperage

Example: Calculate starting amperage required for a 230 V, 1/4 HP motor with a motor start code of M.

Volts = 230, HP = 1/4, kVA/HP = 11.2

$(11.2 \times 1/4 \times 1000) / 230 = 12.2A$

Starting the motor requires 12.2 amperes.

S-0624

11-9. How Much Power Can Generator Supply?



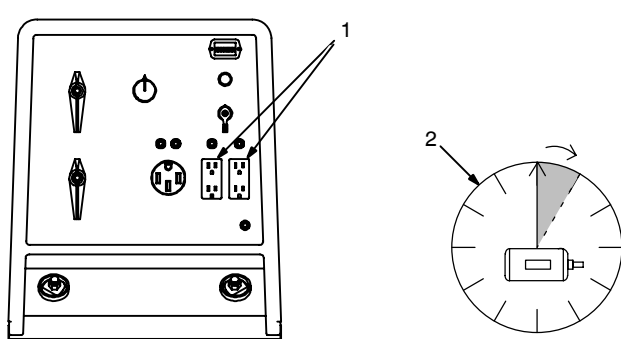

- 1 Limit Load To 90% Of Generator Output

Always start non-resistive (motor) loads in order from largest to smallest, and add resistive loads last.

- 2 5 Second Rule

If motor does not start within 5 seconds, turn off power to prevent motor damage. Motor requires more power than generator can supply.

Ref. ST-800 396-A / S-0625

11-10. Typical Connections To Supply Standby Power

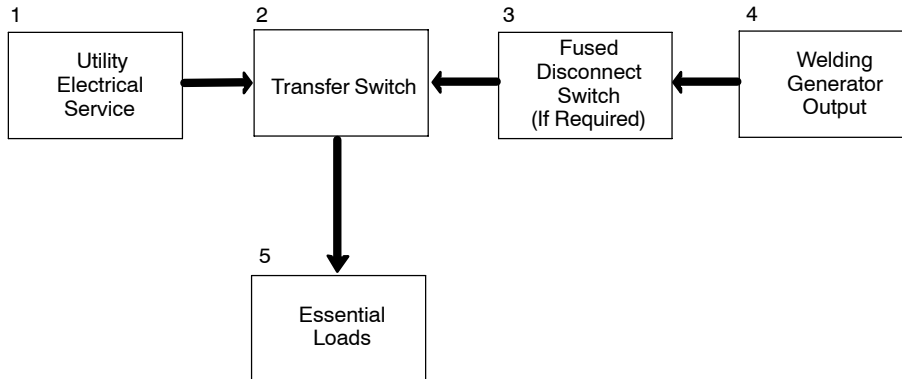

⚠ Have only qualified persons perform these connections according to all applicable codes and safety practices.

⚠ Properly install and ground this equipment according to its Owner's Manual and national, state, and local codes.

☞ Customer-supplied equipment is required if generator will supply standby power during emergencies or power outages.

1 Utility Electrical Service

2 Transfer Switch (Double-Throw)

Switch transfers the electrical load from electric utility service to the generator. Transfer load back to electric utility when service is restored.

Install correct switch (customer-supplied). Switch rating must be same as or greater than the branch overcurrent protection.

3 Fused Disconnect Switch

Install correct switch (customer-supplied) if required by electrical code.

4 Welding Generator Output

Generator output voltage and wiring must be consistent with regular (utility) system voltage and wiring.

Connect generator with temporary or permanent wiring suitable for the installation.

Turn off or unplug all equipment connected to generator before starting or stopping engine. When starting or stopping, the engine has low speed which causes low voltage and frequency.

5 Essential Loads

Generator output may not meet the electrical requirements of the premises. If generator does not produce enough output to meet all requirements, connect only essential loads (pumps, freezers, heaters, etc. – See Section 11-4).

11-11. Selecting Extension Cord (Use Shortest Cord Possible)

Cord Lengths for 120 Volt Loads							
							
⚠ If unit does not have GFCI receptacles, use GFCI-protected extension cord.							
Current (Amperes)	Load (Watts)	Maximum Allowable Cord Length in ft (m) for Conductor Size (AWG)*					
		4	6	8	10	12	14
5	600			350 (106)	225 (68)	137 (42)	100 (30)
7	840		400 (122)	250 (76)	150 (46)	100 (30)	62 (19)
10	1200	400 (122)	275 (84)	175 (53)	112 (34)	62 (19)	50 (15)
15	1800	300 (91)	175 (53)	112 (34)	75 (23)	37 (11)	30 (9)
20	2400	225 (68)	137 (42)	87 (26)	50 (15)	30 (9)	
25	3000	175 (53)	112 (34)	62 (19)	37 (11)		
30	3600	150 (46)	87 (26)	50 (15)	37 (11)		
35	4200	125 (38)	75 (23)	50 (15)			
40	4800	112 (34)	62 (19)	37 (11)			
45	5400	100 (30)	62 (19)				
50	6000	87 (26)	50 (15)				

*Conductor size is based on maximum 2% voltage drop

Cord Lengths for 240 Volt Loads							
							
⚠ If unit does not have GFCI receptacles, use GFCI-protected extension cord.							
Current (Amperes)	Load (Watts)	Maximum Allowable Cord Length in ft (m) for Conductor Size (AWG)*					
		4	6	8	10	12	14
5	1200			700 (213)	450 (137)	225 (68)	200 (61)
7	1680		800 (244)	500 (152)	300 (91)	200 (61)	125 (38)
10	2400	800 (244)	550 (168)	350 (107)	225 (69)	125 (38)	100 (31)
15	3600	600 (183)	350 (107)	225 (69)	150 (46)	75 (23)	60 (18)
20	4800	450 (137)	275 (84)	175 (53)	100 (31)	60 (18)	
25	6000	350 (107)	225 (69)	125 (38)	75 (23)		
30	7000	300 (91)	175 (53)	100 (31)	75 (23)		
35	8400	250 (76)	150 (46)	100 (31)			
40	9600	225 (69)	125 (38)	75 (23)			
45	10,800	200 (61)	125 (38)				
50	12,000	175 (53)	100 (31)				

*Conductor size is based on maximum 2% voltage drop

SECTION 12 – PARTS LIST

 Hardware is common and not available unless listed.

Wiring harnesses are listed at the end of parts section.

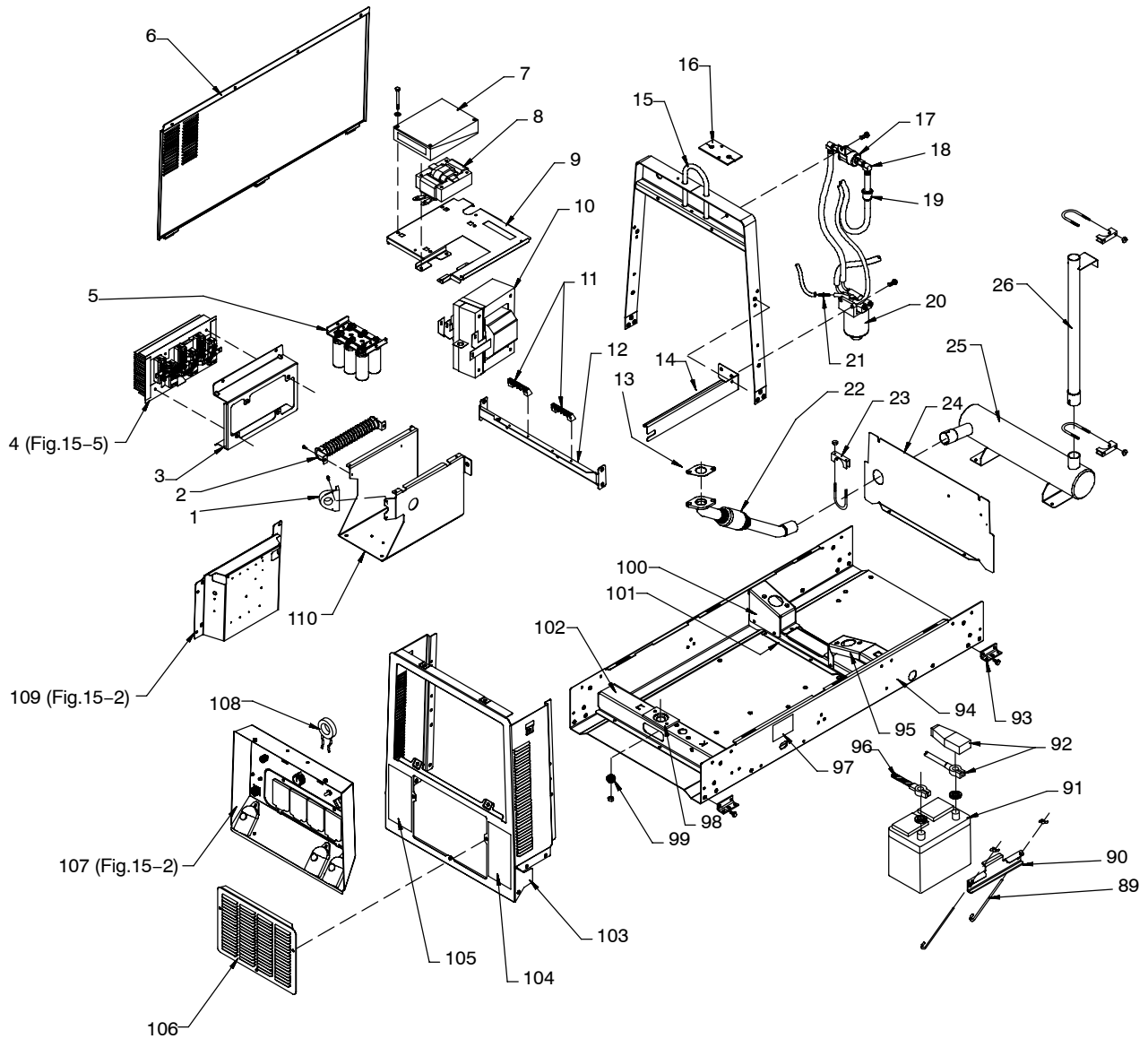
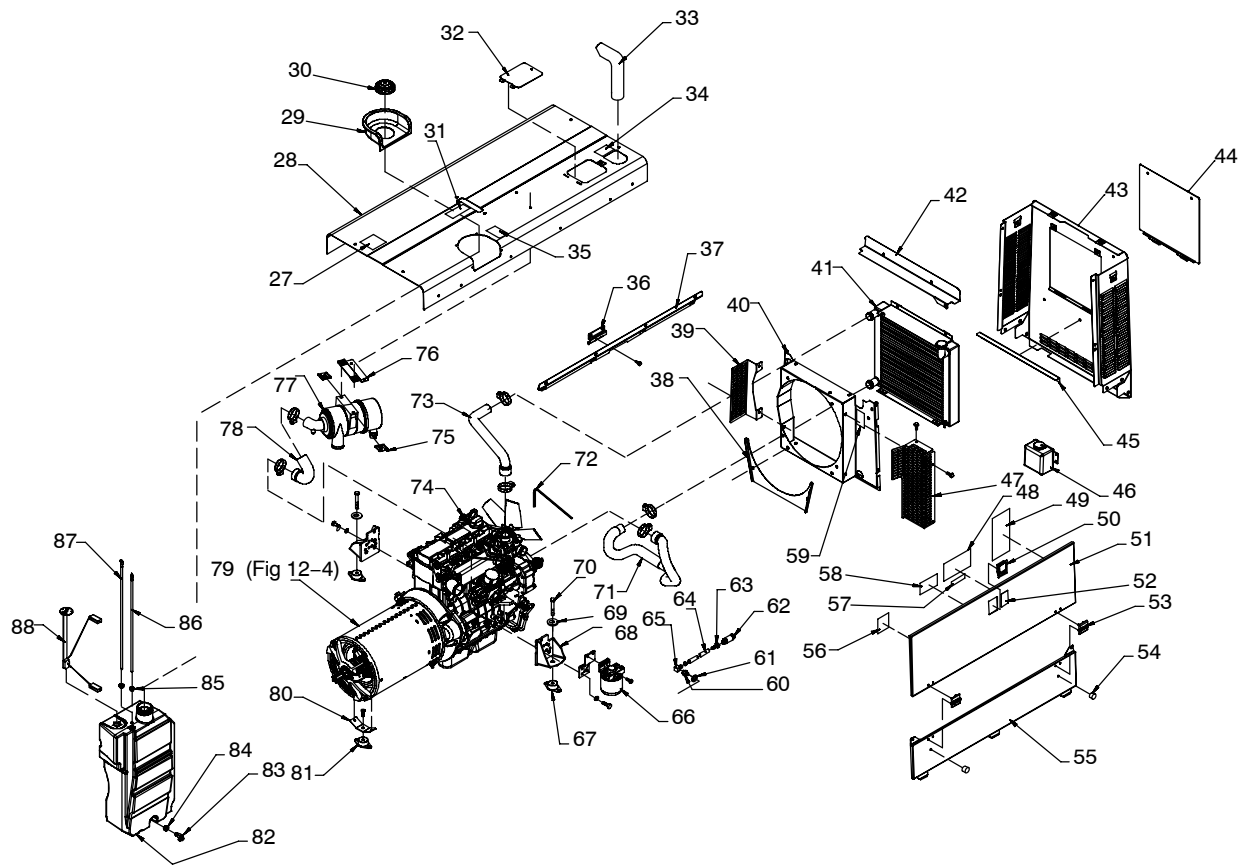

Figure 12-1. Main Assembly



Item No.	Dia. Mkgs.	Part No.	Description	Quantity	
Figure 12-1. Main Assembly					
...	1	HD1	168829	Transducer, Current 1000a Module Max Open Loop	1
...	2	R3	213027	Resistor, WW Tap 300 W 40 Ohm	1
...	3		217070	Bracket, Rectifier	1
...	4		Figure 12-5	Rectifier Assembly	1
...			181853	Insulator, Screw (For Rectifier Mtg)	2
...	5		214742	Capacitor Assy (Includes)	1
...			213489	Bus Bar, Capacitor Bank Negative	1
...			213490	Bus Bar, Capacitor Bank Positive	1
...		C10	163535	Capacitor, Elctlt 16000 Uf 60 Vdc Can 1.75 Dia	6
...	6		+213488	Panel, Engine Side	1
...	7	PC1	231705	Module, Main Control/Scr Gating	1
...	8	T1	232445	Xfmr, Control	1
...	9		232425	Bracket, Vault	1
...	10	Z1	213929	Stabilizer	1
...			192303	Angle, Mtg Stabilizer	2
...	11	TE1, TE2	172661	Block, Stud Connection 6 Position	2
...			173734	Link, Jumper	3
...	12		213500	Brkt, Beam Support	1
...	13		213602	Gasket, Exhaust Outlet Cat 3013	1
...	14		214753	Bracket, Holddown Fuel Tank	1
...	15		213493	Upright, Center Assy	1
...	16		189464	Seal, Weather Lift Eye	1
...	17		228746	Pump, Fuel	1
...	18		234544	Ftg, Hose Brs Barbed Elbow M 5/16 Tbg X 1/4 Npt	2
...	19		*213858	Filter, Fuel In-line 5/16x5/16 Mic 125 -175	1
...	20		228779	Filter, Fuel Spin-on	1
...	21		237666	Ftg, Hose Brs Splice 5/32 Tbg X 1/4 Tbg	1
...	22		227687	Pipe, Exhaust Flexible Inlet	1
...	23		183314	Clamp, Muffler 1.625 Dia U Pld	3
...	24		212604	Baffle, Air Lower Radiator	1
...	25		226018	Muffler, Exhaust Engine	1
...	26		212605	Pipe, Exhaust Blue Fuel	1
...	27		233088	Label, Danger Using A Generator Indoors Can Kill You In Minutes	1
...	28		+213470	Cover, Top	1
...			049525	Nut, 312-18 U-nut Multi-thread	15
...	29		189052	Grommet, Plastic Neck Filler Fuel	1
...	30		190198	Cap, Tank Screw-on 3.500 In W/Vent W/Lanyard 8"	1
...	31		222513	Label, Warning Falling Equipment Can Cause Serious	1
...	32		201851	Cover, Radiator Access	1
...	33		214604	Pipe, Exhaust Elbow	1
...	34		224265	Label, Warning Hot Exhaust Parts Do Not Touch	1
...	35		192041	Label, Use Diesel Fuel Only	1
...	36		213472	Keeper, Latch Engine Access	1
...	37		213471	Bracket, Cover Top	2
...	38		217387	Baffle, Fan	1
...	39		213503	Guard, Fan	1
...	40		+212607	Shroud, Radiator	1
...	41		233256	Radiator, W/14# Cap 3 Row Core 1.25 In Inlet/Outlet (Includes)	1
...			187120	Cap, Radiator Pressure 14lb	1
...	42		212603	Baffle, Air Upper Radiator	1
...	43		+225400	Upright, Rear	1
...	44		225412	Cover, Radiator Access	1
...	45		220295	Bracket, Stiffener	1
...	46		190190	Tank, Coolant Recovery	1
...	47		228396	Guard, Fan	1
...	48		228246	Label, Diesel Engine Maintenance Deutz 2008L04	1

Item No.	Dia. Mkgs.	Part No.	Description	Quantity
Figure 12-1. Main Assembly (Continued)				
49		237013	Label, Hour/Fuel Meter Usage	1
50		199592	Latch, Paddle Series 20 (Black)	1
51		+213487	Door, Engine Access	1
		191626	Bumper, Door Engine Access	2
52		225120	Label, Warning Moving Parts Can Cause Injury	3
53		189975	Hinge, Door Access 180 Deg	2
54		087341	Bumper, Door 1.000 Od X .750 High Rbr 50 Duro W/O	2
55		213486	Panel, Rocker	1
56		217698	Label, Help Codes	1
57		168385	Label, Warning Battery Explosion Can Blind	1
58		203260	Label, Caution Do Not Use Ether	1
59		225120	Label, Warning Moving Parts Can Cause Injury	1
60			Washer, Oil Drain (Order Thru Engine Manufacturer)	1
61		236978	Ftg, Adapter Oil Drain	1
		199505	Hose Assy, Oil Drain 32.000 Lg (Includes)	1
62		165271	Valve, Oil Drain 3/8-18 Nptf	1
63		176529	Ftg, Hose Brs Barbed Fem 1/2 Tbg X 3/8 Npt	1
64		113854	Hose, Sae .500 Id X .780 Od Xcoil	2.6 Ft.
65		197448	Ftg, Hose Brs Barbed Elbow M 1/2 Tbg X 3/8 Npt	1
66		*228778	Filter, Oil	1
67		213266	Mount, Engine/Generator Flange Mtg	2
68		237218	Bracket, Mtg Engine	2
69		083883	Washer, Lock .402idx0.709odx.087t Stl Split10mm	2
70		049026	Screw, M10-1.5x 25 Hex Hd-pln 8.8 Pln	2
71		227961	Hose, Radiator Lower	1
72		227693	Hose, Radiator Upper	1
73		228780	Belt, Alternator	1
74		237007	Engine, Deutz 2008 (Includes)	1
		228781	Switch, Coolant Temp N.c. 110c	1
		228782	Switch, Lubricating Oil Pressure N.O.	1
75		216811	Clip, Nut Retaining	2
76		228235	Bracket, Mtg Air Cleaner	1
77		197613	Air Cleaner, Intake 5.250 In (Includes)	1
		197675	Dust Ejector, Air Cleaner	1
		*197676	Element, Air Cleaner	1
		197677	Cover Assy, Air Cleaner	1
		197678	Body, Air Cleaner	1
		◆*197679	Element, Air Cleaner Safety	1
78		227694	Hose, Air Intake	1
79		Figure 12-4	Generator Assembly	1
80		213461	Bracket, Mtg Generator	1
81		213266	Mount, Engine/Generator Flange Mtg	1
82		227643	Tank, Fuel (Includes Fuel Cap And Items Below)	1
83		189908	Valve, Drain Fuel 180 Deg Zinc Pld	1
84		181572	Bushing, Tank Fuel	1
85		124253	Bushing, Tank Fuel	1
86		212611	Hose, Fuel Stand Pipe W/3/16 In Ftg (Return)	1
87		212610	Hose, Fuel Stand Pipe W/5/16 In Ftg (Supply)	1
88	SENDER	235191	Sender, Fuel Gauge	1

Item No.	Dia. Mkgs.	Part No.	Description	Quantity
----------	------------	----------	-------------	----------

Figure 12-1. Main Assembly (Continued)

.. 89		213465	.. Bolt, J Stl .312-18 X 7.250 Pld	2
.. 90		213466	.. Bracket, Battery Holddown	1
.. 91	BATT	146237	.. Battery, Stor 12v 585 Crk 95 Rsv Gp 55 Maint Free	1
.. 92		190207	.. Cable, Bat Pos 45 In Lg No 1 Awg W/Clamp & .406 Rng	1
.. 93		213668	.. Bracket, Mtg Unit	4
.. 94		213458	.. Base	1
.. 95		213483	.. Support, Engine Rh	1
.. 96		190206	.. Cable, Bat Neg 42 In Lg 2 Awg W/Clamp & .375 Rng	1
.. 97		224266	.. Label, Warning Do Not Weld On Base	2
.. 98		213462	.. Pad, Mtg Generator	1
		213670	.. Screw, 500-13x2.25 Hex Flange-hd Gr8 Pln Chem/Phys	2
		071731	.. Washer, Flat .656idx2.250odx.187t Stl Pld	2
.. 99		213463	.. Spacer/Stubber, Generator Mtg	1
.. 100		213485	.. Support, Engine Lh	1
.. 101		228237	.. Crossmember, Engine	1
.. 102		213460	.. Crossmember, Generator	1
		213600	.. Screw, 500-13x3.00 Hex Flange-hd Gr8 Pln	1
		071731	.. Washer, Flat .656idx2.250odx.187t Stl Pld	2
		213464	.. Bracket, Battery Locator (In Base - Not Shown)	1
		213506	.. Bracket, Hold-Down Fuel Tank (Not Shown)	1
.. 103		+226104	.. Upright, Front	1
.. 104		233953	.. Label, Warning General Precautionary CSA	1
.. 105			.. Label, Rating Card (Provide Serial No. When Ordering)	1
.. 106		220955	.. Panel, Front Access	1
.. 107	Figure 12-2		.. Front Panel Assembly	1
.. 108		◆105370	.. Xfmr, Current	1
.. 109	Figure 12-3		.. Control Panel	1
.. 110		213504	.. Tray, Reactor&Rectifier	1
		213491	.. Insulator, Capacitor Bank (Applies To Reactor/Rectifier Tray)	1

+ When ordering a component originally displaying a precautionary label, the label should also be ordered.

* Recommended Spare Parts.

◆Optional

To maintain the factory original performance of your equipment, use only Manufacturer's Suggested Replacement Parts. Model and serial number required when ordering parts from your local distributor.

☞ Hardware is common and not available unless listed.

Wiring harnesses are listed at the end of parts section.

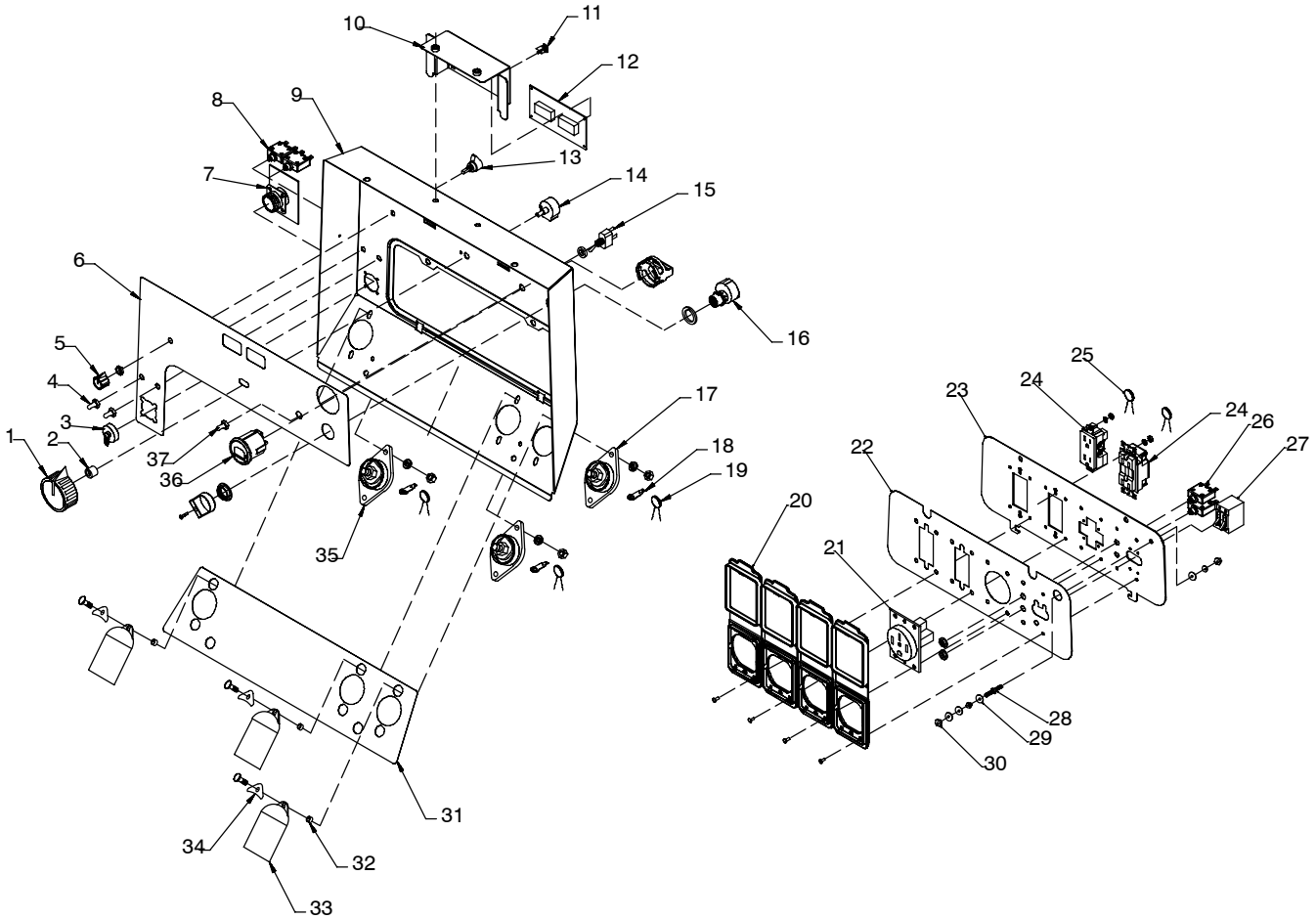

803 684-C

Figure 12-2. Panel, Front w/Components

Item No.	Dia. Mkgs.	Part No.	Description	Quantity
----------	------------	----------	-------------	----------

Figure 12-2. Panel, Front w/Components (Figure 12-1 Item 108)

...	1	097926	.. Knob, Pointer 2.375 Dia X .250 Id W/Set Screwsplstc	1
...	2	072590	.. Lock, Shaft Pot .375-32 X .250 Dia Shaft Tall	1
...	3	170391	.. Conn, Circ Ms Protective Cap Size 20 Nylon	1
...	4	190323	.. Boot, Circuit Breaker Clear Hex Nut	2
...	5	097922	.. Knob, Pointer .875 Dia X .250 Id W/Set Screwsplstc	1
...	6		.. Nameplate, Control (Order By Model & Serial No.)	1
...	7	PC6	.. 229949 .. Circuit Card Assy, Connector/Receptacle	1
...	8	CB7, CB8	.. 083432 .. Supplementary Pro, Man Reset 1p 10a 250vac Frict	2
...	9	213655	.. Panel, Front Engine/Weld Control	1

Item No.	Dia. Mkgs.	Part No.	Description	Quantity
----------	------------	----------	-------------	----------

Figure 12-2. Panel, Front w/Components (Continued)

... 10		214543	.. Enclosure, Circuit Card Assy	1
... 11		134201	.. Stand-off Support, Pc Card .312/.375w/Post&lock .43	4
... 12	PC2	214660	.. Circuit Card Assy, Display W/Program	1
... 13	R1	214760	.. Switch, Rotary 12 Posn 1p 200ma 28vdc W/Resistors	1
... 14	R2	193118	.. Pot, Cp Flat 1t 2. W 1k Ohm Linear	1
... 15	S4	021467	.. Switch, Tgl Spst 3a 250v Off-none-(On) Spd Term	1
... 16	S1	212436	.. Switch, Ignition 4 Position (Includes Knob)	1
... 17		039047	.. Terminal, Pwr Output Red	2
... 18		010381	.. Connector, Rectifier	3
... 19	C13, 14, 15	128750	.. Capacitor, Cer Disc .1 Uf 500 Vdc W/Terms	3
... 20		209056	.. Cover, Receptacle W/Gasket	4
... 21	RC11	182954	.. Rcpt, Str 3p4w 50a 125/250v Flush Mtg *14-50	1
... 22			.. Nameplate, Generator Power (Order By Model & Serial No.)	1
... 23		213509	.. Panel, Power	1
... 24	RC5,6	214918	.. Rcpt,Str Dx Grd 2p3w 20a 125v *5-20r (Order By Model & Serial No.)	
... 24	GFC11, 2	151981	.. Rcpt, Str Dx Grd 2p3w 15/20a 125v *5-20r Gfi (Order By Model & Serial No.)	
... 25	C11, C12	217054	.. Capacitor, Cer Disc .0047 Uf 3000 Vdc W/Terms	2
... 26	CB4, CB6	093996	.. Supplementary Pro, Man Reset 1p 20a 250vac Frict	2
... 27	CB5	203026	.. Supplementary Protector, Man Reset 2p 50a 240vac	1
... 28	GRD	083030	.. Stud, Brs .250-20 X 1.750 W/Hex Collar	1
... 29		010915	.. Washer, Flat .257idx0.640odx.031t Brs	4
... 30		601836	.. Nut, 250-20 .50hex .19h Brs	3
... 31			.. Nameplate, Weld Terminal (Order By Model & Serial No.)	1
... 32		181169	.. Spacer, Output Stud	3
... 33		186621	.. Boot, Generic Output Stud	3
... 34		180735	.. Washer, Output Stud	3
... 35		039046	.. Terminal, Pwr Output Black	1
... 36	FUEL/HM	232111	.. Gauge, Fuel Elec/Hour Meter	1
... 37		021385	.. Boot, Toggle Switch Lever	1

◆ Optional

+ When ordering a component originally displaying a precautionary label, the label should also be ordered.

To maintain the factory original performance of your equipment, use only Manufacturer's Suggested Replacement Parts. Model and serial number required when ordering parts from your local distributor.

☞ Hardware is common and not available unless listed.

Wiring harnesses are listed at the end of parts section.

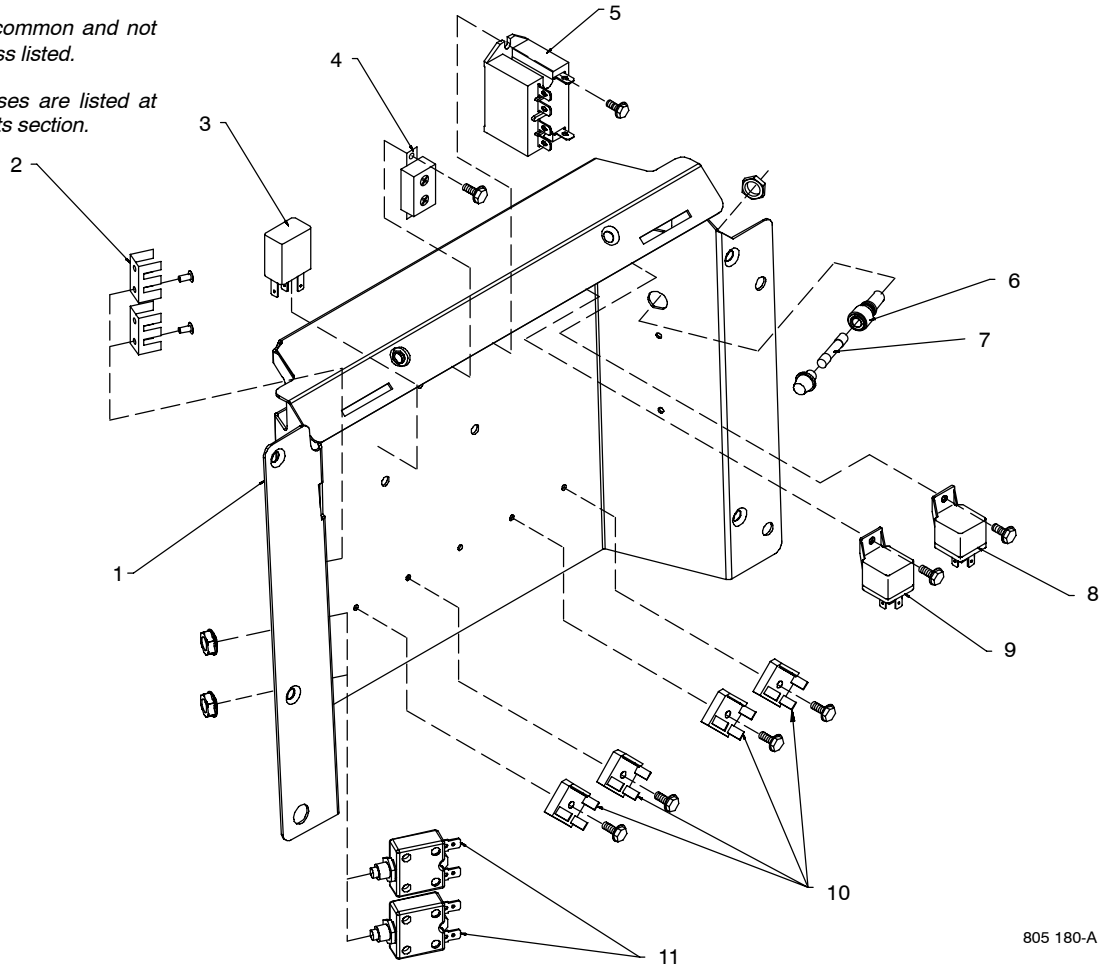

805 180-A

Figure 12-3. Control Panel

Item No.	Dia. Mkgs.	Part No.	Description	Quantity
----------	------------	----------	-------------	----------

Figure 12-3. Control Panel (Figure 12-1 Item 109)

...	1	220981	Bracket, Mtg Components	1
...	2	129524	Term, Frict 250x032 Uninsul Male .130 Stud Mtg 3pr	2
...	3	CR2 214876	Relay, Encl 6vdc Spst 35a/14vdc 5 Pin	1
...	4	CB1 190374	Circuit Breaker, Auto Reset 12vdc 40 Amp	1
...	5	CR1 223710	Relay, Encl 12vdc Dpst-no 25a 6pin Flange	1
...	6	046432	Holder, Fuse Mintr .250 X 1.250 Panel Mtg	1
...	7	F1 085874	Fuse, Mintr Cer Slo-blo 10. Amp 250 Volt	1
...	8	CR4 ♦090104	Relay, Encl 12vdc Spst 30a/15vdc 5pin Flange Mtg	1
...	9	CR3 197325	Relay, Encl 12vdc Spst 70a 4pin Flange Mtg	1
...	10	SR1,2,4,5 035704	Rectifier, Integ Bridge 40. Amp 800v	4
...	11	CB2, CB3 083432	Supplementary Pro, Man Reset 1p 10a 250vac Frict	2

♦Optional

+ When ordering a component originally displaying a precautionary label, the label should also be ordered.

To maintain the factory original performance of your equipment, use only Manufacturer's Suggested Replacement Parts. Model and serial number required when ordering parts from your local distributor.

☞ Hardware is common and not available unless listed.

Wiring harnesses are listed at the end of parts section.

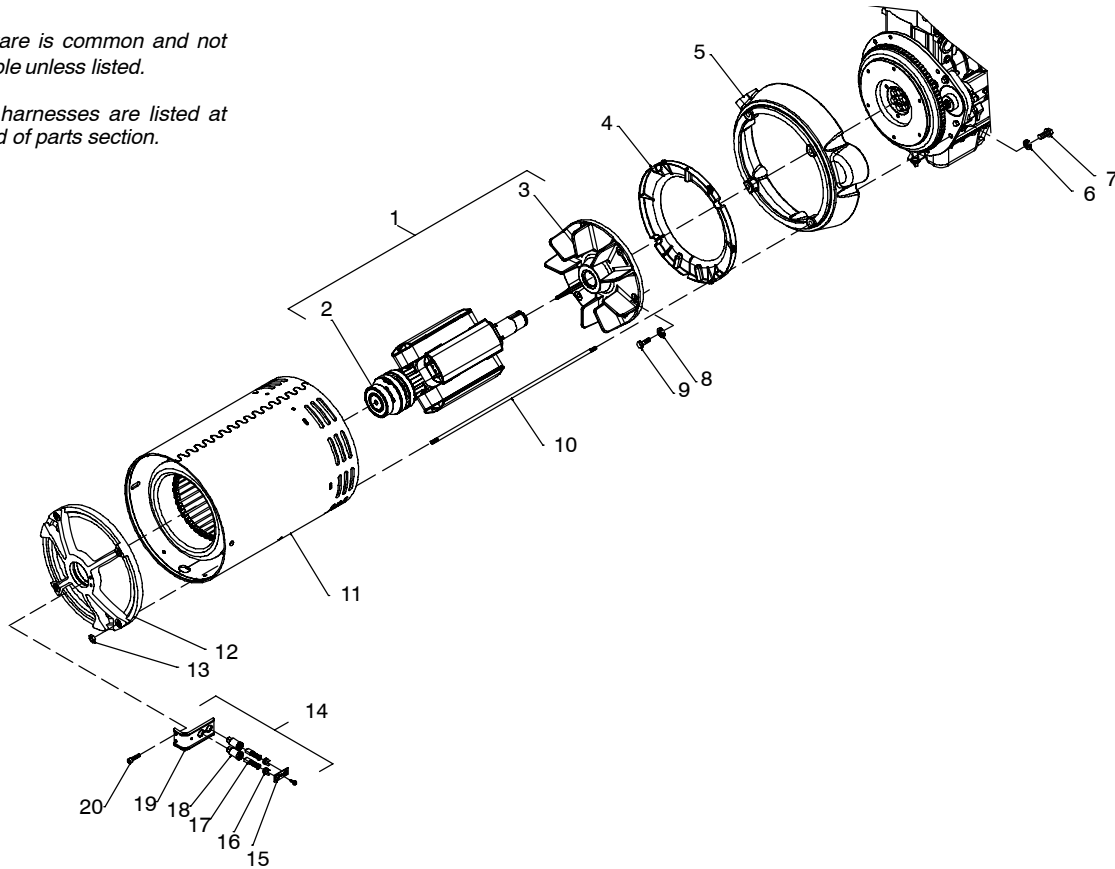

805 179-A

Figure 12-4. Generator

Item No.	Dia. Mkgs.	Part No.	Description	Quantity
----------	------------	----------	-------------	----------

Figure 12-4. Generator (Figure 12-1 Item 79)

...	1	...	ROTOR	...	212474	..	Rotor, Generator 4 Pole (Includes)	1
...	2	053390	Bearing, Ball Rdl Sgl Row 1.370 X 2.830 X .6	1
...	3	192600	Fan, Generator	1
...	4	159918	..	Baffle, Fan	1
...	5	227060	..	Adapter, Engine Machined	1
...	6	083883	..	Washer, Lock .402idx0.709odx.087t Stl Pln Split10mm	6
...	7	601965	..	Screw, 375-16x1.00 Hex Hd-pln Gr5 Pld	6
...	8	602211	..	Washer, Lock .318idx0.586odx.078t Stl Pld Split.312	6
...	9	192686	..	Screw, M 8-1.25x 25 Hex Hd-pln 8.8 Pld Din933	6
...	10	212641	..	Stud, Stl .375-16 1.625x 19.000	4
...	11	..	STATOR	..	235013	..	Stator, Generator 4 Pole	1
...	12	160943	..	Endbell	1
...	13	167788	..	Nut, 375-16 .56hex .34h Stl Pld Sem Cone Wshr.88d	4
...	14	218552	..	Brush, Assembly 2 Pole (Includes)	1
...	15	047879	Bar, Retaining Brushholder 2 Brushes	1
...	16	161306	Cap, Brushholder	2
...	17	126984	Brush w/Spring	2
...	18	005614	Holder, Brush	2
...	19	125548	Holder, Brush Elect	1
...	20	158832	..	Screw, 010-32x .50 Hex Hd-slt Stl Pld Sq Cone Sems	2

+ When ordering a component originally displaying a precautionary label, the label should also be ordered.

*Recommended Spare Parts.

◆Optional

To maintain the factory original performance of your equipment, use only Manufacturer's Suggested Replacement Parts. Model and serial number required when ordering parts from your local distributor.

☞ Hardware is common and not available unless listed.

Wiring harnesses are listed at the end of parts section.

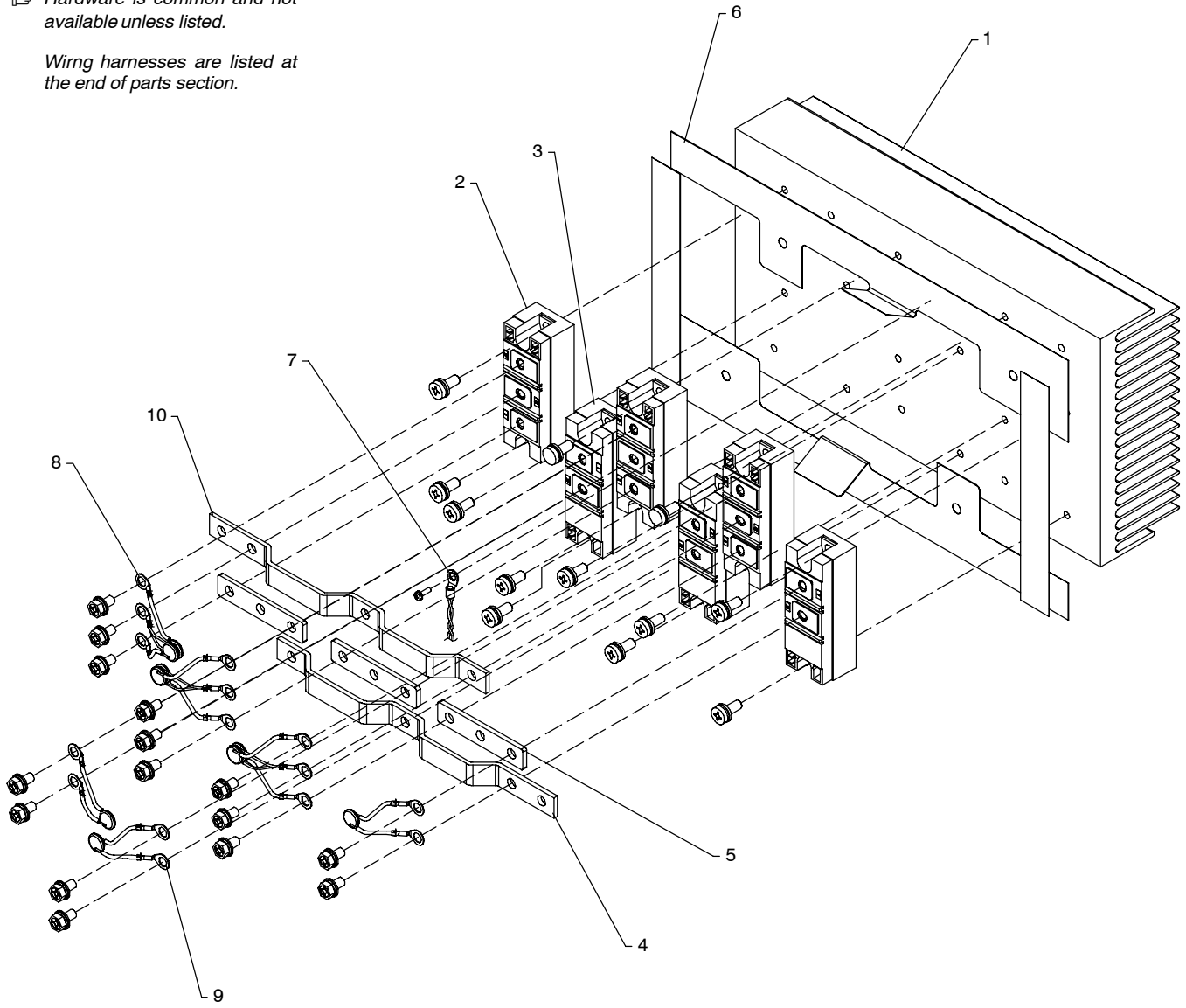

803 685-A

Figure 12-5. Rectifier Assembly

Item No.	Dia. Mkgs.	Part No.	Description	Quantity
----------	------------	----------	-------------	----------

Figure 12-5. Rectifier Assembly (Figure 12-1 Item 4)

.....		217081	Rectifier, Assembly (Includes)	1
... 1		211984	Heat Sink	1
... 2	MOD1,2,3	218296	Kit, Module SCR	3
... 3	MOD4,5,6	218292	Kit, Module SCR	3
... 4		212602	Bus Bar, Rectifier	1
... 5		212639	Bus Bar, Rectifier	3
... 6		212601	Insulator, Rectifier	1
... 7	TH1	213930	Thermistor, Ntc 30k Ohm @ 25 Deg C 8.5in Lead	1
... 8	C1-6	215611	Capacitor Assy	3
... 9	C7,8,9	048420	Capacitor, Cer Disc .01 Uf 1000 Vdc W/Terms	3
... 10		217085	Bus Bar, Rectifier	1
.....		181853	Insulator, Screw (For Mounting Rectifier)	4

To maintain the factory original performance of your equipment, use only Manufacturer's Suggested Replacement Parts. Model and serial number required when ordering parts from your local distributor.

☞ Some wiring harness components (switches, relays, supplementary protectors) are also referenced elsewhere in this parts list. Purchase components separately or as part of the associated wiring harness.

Item No.	Dia. Mkgs.	Part No.	Description	Quantity
Wiring Harnesses				
		231122	Harness, Engine (Includes)	1
	S4	021467	Switch, Tgl Spst 3a 250v Off–none–(On) Spd Term	1
	SR1, SR2	035704	Rectifier, Integ Bridge 40. Amp 800v	2
	CB1	190374	Circuit Breaker, Auto Reset 12vdc 40 Amp	1
	CB2, CB3	083432	Supplementary Pro, Man Reset 1p 10a 250vac Frict	2
	CR3	197325	Relay, Encl 12vdc Spst 70a 4pin Flange Mtg	1
	CR2	214876	Relay, Encl 6vdc Spst 35a/14vdc 5 Pin	1
	R4	217335	Resistor Board,	1
		148850	Socket, Relay 5 Pin	1
		212116	Conn, Deutsch 2p 1row Female Plug	3
		212117	Conn, Deutsch Wedge Lock 2 Position	3
	PLG1	214932	Conn, Rect Univ 039 8p/S 2row Plug Cable Lkg Seal	1
		214933	Seal, Wire Univ 039	7
		214934	Seal, Plug Univ 039	1
	For S1	211292	Conn, Pack 4p 1row Female	1
	For S1	211293	Conn, Pack Terminal Position Assurance(Lock)	1
		129524	Term, Frict 250x032 Uninsul Male .130 Stud Mtg 3pr	2
		217002	Harness, Weld Control (Includes)	1
	PLG2	150316	Conn, Rect Univ 039 6p/S 3row Plug Cable Lkg	1
	PLG9	214951	Conn, Rect Univ 039 6p/S 3row Plug Cable Lkg Seal	1
		214933	Seal, Wire Univ 039	3
		214934	Seal, Plug Univ 039	3
	PLG8	147992	Conn, Rect Univ 039 10p/S 2row Plug Cable Lkg	1
	PLG6	193184	Conn, Rect Cinch 30 Pin	1
	PLG7	193183	Conn, Rect Cinch 18 Pin	1
	PLG9	215261	Conn, Deutsch 12p 2row Female Plug	1
	PLG10	215262	Conn, Deutsch 12p 2row Female Plug	1
		215265	Conn, Deutsch Wedge Lock 12 Position	2
		215343	Seal, Plug Deutsch 12–16 Size	7
	PLG5	113750	Conn, Rect Mini 045 4skt 2row Plug Cable Lkg	1
		217000	Cable, Lem	1
		215340	Conn, Rect Univ 039 2p/S 1row Rcpt Cable/Pnl Lkg S	1
		214933	Seal, Wire Univ 039	2
		214984	Harness, Rectifier Cc/Cv (Includes)	1
	PLG11	193183	Conn, Rect Cinch 18 Pin	1
		207716	Conn, Faston Mini Polarized 2 Skt G1k1	6
		207718	Conn, Faston Mini Polarized 2 Skt G2k2	3
		217010	Harness, Receptacle Auxiliary Power (Includes)	1
	CB4, CB6	093996	Supplementary Pro, Man Reset 1p 20a 250vac Frict	2

TRUE BLUE[®]

WARRANTY

Effective January 1, 2008

(Equipment with a serial number preface of LJ or newer)

This limited warranty supersedes all previous Miller warranties and is exclusive with no other guarantees or warranties expressed or implied.

Warranty Questions?

Call
1-800-4-A-MILLER
for your local
Miller distributor.

Your distributor also gives
you ...

Service

You always get the fast,
reliable response you
need. Most replacement
parts can be in your
hands in 24 hours.

Support

Need fast answers to the
tough welding questions?
Contact your distributor.
The expertise of the
distributor and Miller is
there to help you, every
step of the way.

LIMITED WARRANTY – Subject to the terms and conditions below, Miller Electric Mfg. Co., Appleton, Wisconsin, warrants to its original retail purchaser that new Miller equipment sold after the effective date of this limited warranty is free of defects in material and workmanship at the time it is shipped by Miller. THIS WARRANTY IS EXPRESSLY IN LIEU OF ALL OTHER WARRANTIES, EXPRESS OR IMPLIED, INCLUDING THE WARRANTIES OF MERCHANTABILITY AND FITNESS.

Within the warranty periods listed below, Miller will repair or replace any warranted parts or components that fail due to such defects in material or workmanship. Miller must be notified in writing within thirty (30) days of such defect or failure, at which time Miller will provide instructions on the warranty claim procedures to be followed.

Miller shall honor warranty claims on warranted equipment listed below in the event of such a failure within the warranty time periods. All warranty time periods start on the delivery date of the equipment to the original end-user purchaser, and not to exceed one year after the equipment is shipped to a North American distributor or eighteen months after the equipment is shipped to an International distributor.

1. 5 Years Parts — 3 Years Labor
 - * Original main power rectifiers only to include SCRs, diodes, and discrete rectifier modules
2. 3 Years — Parts and Labor
 - * Transformer/Rectifier Power Sources
 - * Plasma Arc Cutting Power Sources
 - * Process Controllers
 - * Semi-Automatic and Automatic Wire Feeders
 - * Inverter Power Sources (Unless Otherwise Stated)
 - * Water Coolant Systems (Integrated)
 - * Intelligit
 - * Engine Driven Welding Generators
(NOTE: Engines are warranted separately by the engine manufacturer.)
3. 1 Year — Parts and Labor Unless Specified
 - * Motor Driven Guns (w/exception of Spoolmate Spoolguns)
 - * Positioners and Controllers
 - * Automatic Motion Devices
 - * RFCS Foot Controls
 - * Induction Heating Power Sources, Coolers, and Electronic Controls/Recorders
 - * Water Coolant Systems (Non-Integrated)
 - * Flowgauge and Flowmeter Regulators (No Labor)
 - * HF Units
 - * Grids
 - * Spot Welders
 - * Load Banks
 - * Arc Stud Power Sources & Arc Stud Guns
 - * Racks
 - * Running Gear/Trailers
 - * Plasma Cutting Torches (except APT & SAF Models)
 - * Field Options
(NOTE: Field options are covered under True Blue[®] for the remaining warranty period of the product they are installed in, or for a minimum of one year — whichever is greater.)
 - * Bernard-Branded Mig Guns (No Labor)
 - * Weldcraft-Branded TIG Torches (No Labor)
 - * Subarc Wire Drive Assemblies
4. 6 Months — Batteries
5. 90 Days — Parts
 - * MIG Guns and Subarc (SAW) Guns

- * Induction Heating Coils and Blankets, Cables, and Non-Electronic Controls
- * APT & SAF Model Plasma Cutting Torches
- * Remote Controls
- * Accessory (Kits)
- * Replacement Parts (No labor)
- * Spoolmate Spoolguns
- * Canvas Covers

Miller's True Blue[®] Limited Warranty shall not apply to:

1. **Consumable components; such as contact tips, cutting nozzles, contactors, brushes, slip rings, relays or parts that fail due to normal wear. (Exception: brushes, slip rings, and relays are covered on Bobcat, Trailblazer, and Legend models.)**
2. Items furnished by Miller, but manufactured by others, such as engines or trade accessories. These items are covered by the manufacturer's warranty, if any.
3. Equipment that has been modified by any party other than Miller, or equipment that has been improperly installed, improperly operated or misused based upon industry standards, or equipment which has not had reasonable and necessary maintenance, or equipment which has been used for operation outside of the specifications for the equipment.

MILLER PRODUCTS ARE INTENDED FOR PURCHASE AND USE BY COMMERCIAL/INDUSTRIAL USERS AND PERSONS TRAINED AND EXPERIENCED IN THE USE AND MAINTENANCE OF WELDING EQUIPMENT.

In the event of a warranty claim covered by this warranty, the exclusive remedies shall be, at Miller's option: (1) repair; or (2) replacement; or, where authorized in writing by Miller in appropriate cases, (3) the reasonable cost of repair or replacement at an authorized Miller service station; or (4) payment of or credit for the purchase price (less reasonable depreciation based upon actual use) upon return of the goods at customer's risk and expense. Miller's option of repair or replacement will be F.O.B., Factory at Appleton, Wisconsin, or F.O.B. at a Miller authorized service facility as determined by Miller. Therefore no compensation or reimbursement for transportation costs of any kind will be allowed.

TO THE EXTENT PERMITTED BY LAW, THE REMEDIES PROVIDED HEREIN ARE THE SOLE AND EXCLUSIVE REMEDIES. IN NO EVENT SHALL MILLER BE LIABLE FOR DIRECT, INDIRECT, SPECIAL, INCIDENTAL OR CONSEQUENTIAL DAMAGES (INCLUDING LOSS OF PROFIT), WHETHER BASED ON CONTRACT, TORT OR ANY OTHER LEGAL THEORY.

ANY EXPRESS WARRANTY NOT PROVIDED HEREIN AND ANY IMPLIED WARRANTY, GUARANTY OR REPRESENTATION AS TO PERFORMANCE, AND ANY REMEDY FOR BREACH OF CONTRACT TORT OR ANY OTHER LEGAL THEORY WHICH, BUT FOR THIS PROVISION, MIGHT ARISE BY IMPLICATION, OPERATION OF LAW, CUSTOM OF TRADE OR COURSE OF DEALING, INCLUDING ANY IMPLIED WARRANTY OF MERCHANTABILITY OR FITNESS FOR PARTICULAR PURPOSE, WITH RESPECT TO ANY AND ALL EQUIPMENT FURNISHED BY MILLER IS EXCLUDED AND DISCLAIMED BY MILLER.

Some states in the U.S.A. do not allow limitations of how long an implied warranty lasts, or the exclusion of incidental, indirect, special or consequential damages, so the above limitation or exclusion may not apply to you. This warranty provides specific legal rights, and other rights may be available, but may vary from state to state.

In Canada, legislation in some provinces provides for certain additional warranties or remedies other than as stated herein, and to the extent that they may not be waived, the limitations and exclusions set out above may not apply. This Limited Warranty provides specific legal rights, and other rights may be available, but may vary from province to province.

miller_warr 2008-01





Owner's Record

Please complete and retain with your personal records.

Model Name

Serial/Style Number

Purchase Date

(Date which equipment was delivered to original customer.)

Distributor

Address

City

State

Zip



For Service

Contact a DISTRIBUTOR or SERVICE AGENCY near you.

Always provide Model Name and Serial/Style Number.

Contact your Distributor for:

Welding Supplies and Consumables

Options and Accessories

Personal Safety Equipment

Service and Repair

Replacement Parts

Training (Schools, Videos, Books)

Technical Manuals (Servicing Information and Parts)

Circuit Diagrams

Welding Process Handbooks

To locate a Distributor or Service Agency visit www.millerwelds.com or call 1-800-4-A-Miller

Contact the Delivering Carrier to:

File a claim for loss or damage during shipment.

For assistance in filing or settling claims, contact your distributor and/or equipment manufacturer's Transportation Department.

Miller Electric Mfg. Co.

An Illinois Tool Works Company
1635 West Spencer Street
Appleton, WI 54914 USA

International Headquarters—USA

USA Phone: 920-735-4505 Auto-Attended
USA & Canada FAX: 920-735-4134
International FAX: 920-735-4125

European Headquarters – United Kingdom

Phone: 44 (0) 1204-593493
FAX: 44 (0) 1204-598066

www.MillerWelds.com

