



TM-238 119K

2012-01

Processes



MIG (GMAW) Welding



Flux Cored (FCAW) Welding

Description



Arc Welding Power Source
and Wire Feeder

Millermatic[®] 212 Auto-Set[™]

Eff w/LJ180755B And Following
For OM-238 118 Revision A And Following

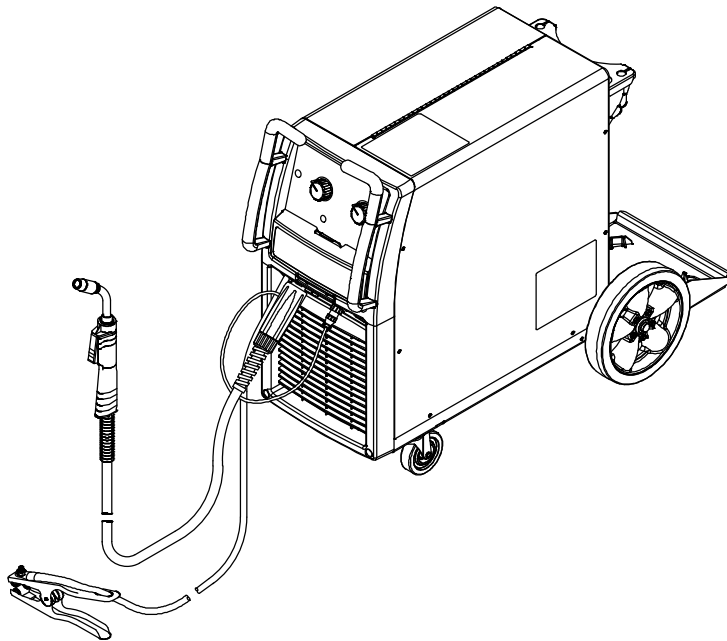

Visit our website at
www.MillerWelds.com

PARTS LIST

File: MIG (GMAW)



SECTION 1 – PARTS LIST

 Hardware is common and not available unless listed.

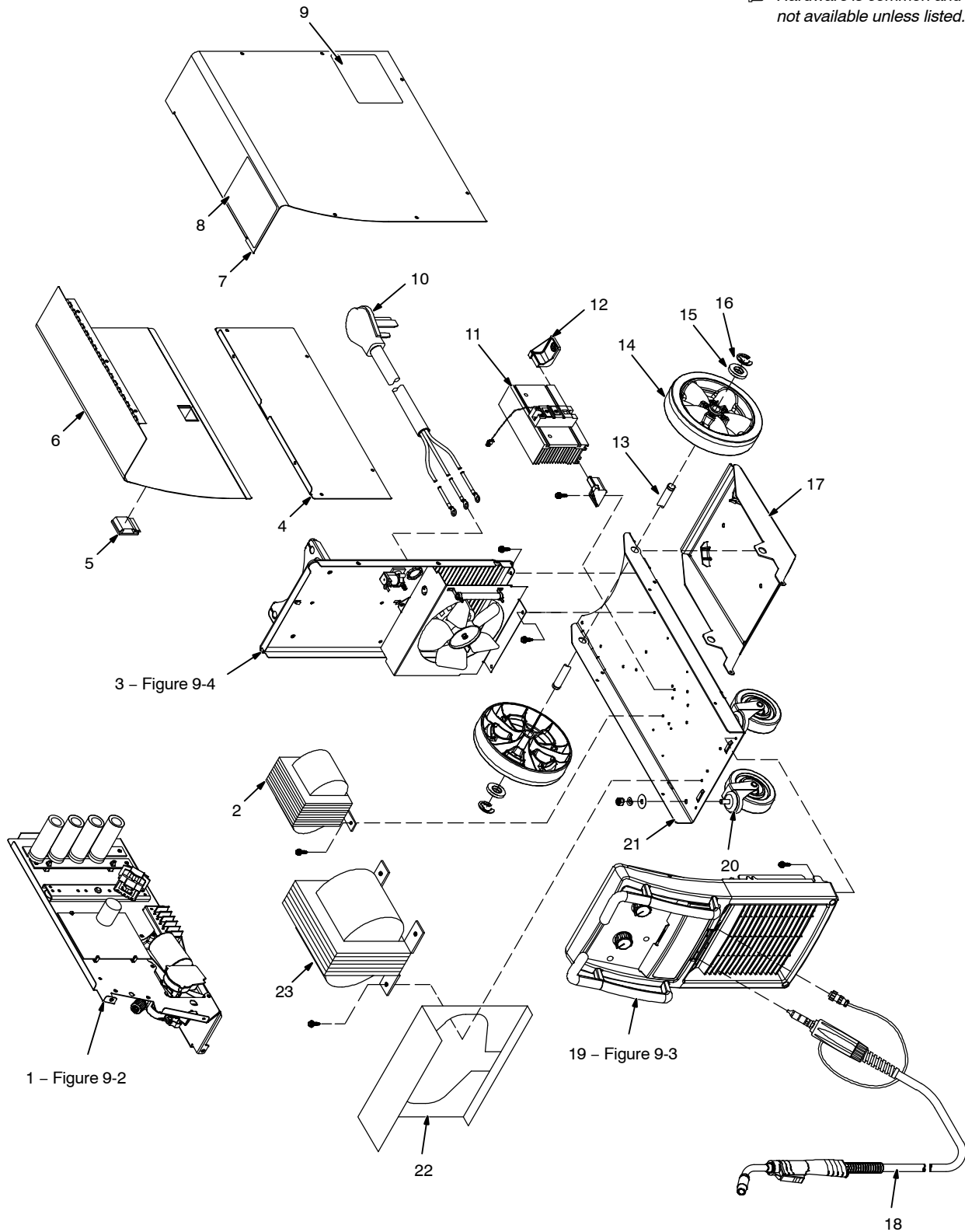

805 245-A

Figure 9-1. Main Assembly

Item No.	Dia. Mkgs.	Part No.	Description	Quantity
Figure 9-1. Main Assembly				
1		Figure 9-2	BAFFLE,CENTER W/COMPONENTS	1
2	Z1	254111	STABILIZER,	1
3		Figure 9-4	PANEL,REAR W/COMPONENTS,	1
4		229621	PANEL,SIDE LH LOWER	1
5		230363	LATCH,SLIDE FLUSH MTG HOLE 1.750 WIDEX 1.500 LG	1
6		229620	DOOR,HINGED	1
7		+229619	WRAPPER,	1
8		231983	LABEL,WARNING GENERAL PRECAUTIONARY (EN/SP)	1
9		231984	LABEL,WARNING ELECTRIC SHOCK/INCORR INPUT (EN/SP)	1
10		199192	CORD SET,250V 6-50P 12GA 3/C 9FT ST JKT)	1
11		238084	RECTIFIER ASSY,SCR MAIN (INCLUDING)	1
12		205946	FOOT,MTG RECTIFIER	2
		238082	RECTIFIER,SCR MAIN (INCLUDING)	1
	SR1	238085	THYRISTOR,SCR MODULE 150A 400V COMMON ANODE	1
		232261	HEAT SINK,RECTIFIER	1
	C3,4	219460	CAPACITOR,CER DISC .01 UF 1000 VDC W/TERMS	2
	RT1	199798	THERMISTOR,NTC 30K OHM @ 25 DEG C 18.00IN2500V	1
13		230798	AXLE,RUNNING GEAR .750 DIA X 18.000	1
14		230799	WHEEL,POLYPROPYLENE 10 IN X 2.25 WIDE	2
15		602250	WASHER,FLAT .812IDX1.469ODX.134T STL PLD ANSI.750	2
16		121614	RING,RTNG EXT .750 SHAFT X .085 THK E STYLE PLD	2
17		229625	TRAY,CYLINDER LOW	1
18		169598	M-25 GUN 15 FT .030-.035 WIRE (SEE GUN OWMER'S MANUAL)	1
19		Figure 9-3	PANEL,FRONT W/COMPONENTS,	1
20		235875	CASTER,SWVL 4.00 IN POLYOLEFIN X 1.250 IN WIDE	2
21		229624	BASE,	1
22		230364	BAFFLE,AIR XFMR (Prior to MA200338N)	1
22		248427	BAFFLE,AIR XFMR (Eff w/MA200338N)	1
		248426	BLANK,SNAP-IN	2
23	T1	237521	XFMR,POWER MAIN 203/230	1
	PLG8	110759	HOUSING RCPT+SKTS,(SERVICE KIT)	1
		234263	REGULATOR/FLOWMETER, 0-50 CFH AR/CO2/MIX W/FILTER	1
		196328	CABLE,WORK 10 FT NO 3 W/CLAMP & BOOT (INCLUDING)	1
		233452	CLAMP,WORK 300 AMP	1
		600318	CABLE,WELD COP STRD NO 3 EPDM JKT (ORDER BY FT)	1
		196318	COVER,CABLE BTRY POST BLK .75 ID	1
		144108	HOSE,GAS 5FT	1

+When ordering a component originally displaying a precautionary label, the label should also be ordered.

To maintain the factory original performance of your equipment, use only Manufacturer's Suggested Replacement Parts. Model and serial number required when ordering parts from your local distributor.

☞ Hardware is common and not available unless listed.

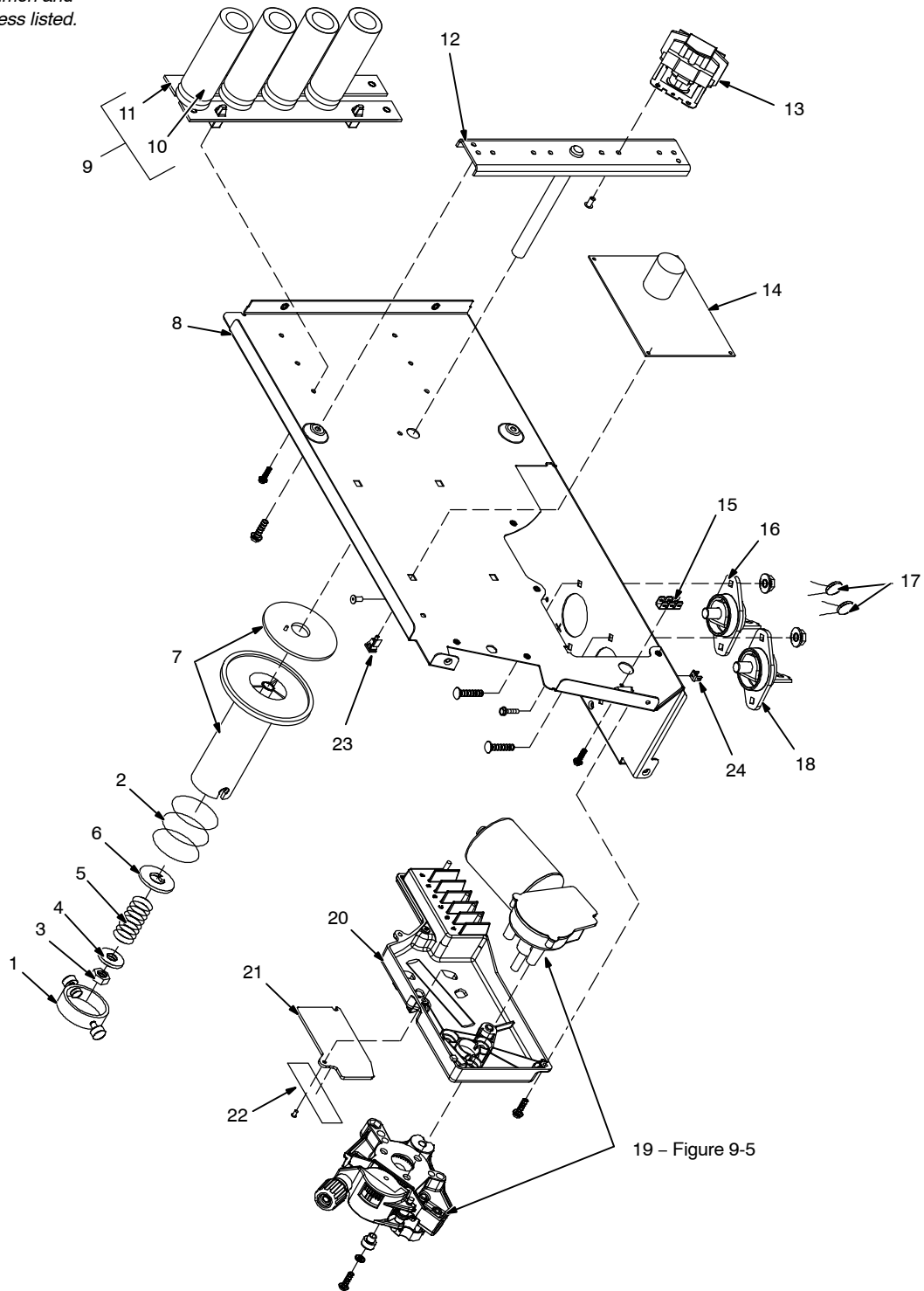

Figure 9-2. Baffle, Center w/Components

805 246-A

Item No.	Dia. Mkgs.	Part No.	Description	Quantity
----------	------------	----------	-------------	----------

Figure 9-2. Baffle, Center w/Components

.....		196001	.. SPOOL HUB ASSEMBLY (INCLUDING)	1
1		058427	.. RING,RETAINING SPOOL	1
2		057745	.. SPRING,CPRSN 2.305 OD X .090 WIRE X 2.500 PLD	1
3		085980	.. NUT, 625-11 .94HEX .54H STL PLD	1
4		605941	.. WASHER,FLAT .640IDX1.000ODX.075T STL PLD	1
5		186437	.. SPRING,CPRSN .845 OD X .110 WIRE X 1.500 PLD	1
6		057971	.. WASHER,FLAT .632IDX1.500ODX.125T STL PLD .175KEY	1
7		238377	.. KIT,SPOOL HUB W/BRAKE WASHER	1
8		229623	.. BAFFLE,CENTER	1
		231985	.. LABEL,WARNING ELECTRIC SHOCK AND PINCH (EN/SP)	1
		226658	.. LABEL,POLARITY/DRIVE ROLLS	1
9	C5	208812	.. CAPACITOR ASSY,	1
10		191374	.. CAPACITOR,ELCTLT 30000 UF 45 VDC CAN 1.75 DIA	4
		083147	.. GROMMET,SCR NO 8/10 PANEL HOLE .312 SQ .500 HIGH	4
11		208218	.. BUSS BAR,CAPACITOR	2
12		235827	.. REEL SUPPORT	1
13	W	229685	.. CONTACTOR,DEF PRP 25A 1P 36VDC COIL	1
14	PC1	249757	.. CIRCUIT CARD ASSY,CONTROL W/PROGRAM (Prior to MA290011N) ...	1
14	PC1	245564	.. CIRCUIT CARD ASSY,CONTROL W/PROGRAM (Eff w/MA290011N)	1
	PLG1	241168	.. HOUSING PLUG+SKTS,(SERVICE KIT)	1
	PLG2	241172	.. HOUSING RCPT+SKTS,(SERVICE KIT)	1
	PLG3	241171	.. HOUSING PLUG+SKTS,(SERVICE KIT)	1
	PLG6	241169	.. HOUSING PLUG+SKTS,(SERVICE KIT)	1
	PLG7	202592	.. HOUSING PLUG+SKTS,(SERVICE KIT)	1
	PLG8	110759	.. HOUSING PLUG+SKTS,(SERVICE KIT)	1
	PLG9	241167	.. HOUSING RCPT+SKTS,(SERVICE KIT)	1
	PLG10	241170	.. HOUSING PLUG+SKTS,(SERVICE KIT)	1
15		129524	.. TERM,FRICT 250X032 UNINSUL MALE .130 STUD MTG 3PR	1
16	POS	097421	.. TERMINAL,PWR OUTPUT RED	1
17	C1,C2	128750	.. CAPACITOR,CER DISC .1 UF 500 VDC W/TERMS	2
18	NEG	097416	.. TERMINAL,PWR OUTPUT BLACK	1
		230795	.. DRIVE ASSY,WIRE W/PRI LINK 2V (INCLUDING)	1
19	Figure 9-5		.. MOTOR AND WIRE DRIVE ASSY	1
		153980	.. LABEL,LINK ARR PRI V 200/230	1
20		229630	.. HOUSING,DRIVE ASSY/PRI TERM LINK 2 VOLTAGE (INCLUDING ...	1
21		+229634	.. DOOR,ACCESS CHANGEOVER	1
22		231987	.. LABEL,WARNING HIGH VOLTAGE (EN/SP)	1
23		134201	.. STAND-OFF SUPPORT,PC CARD .312/.375W/POST&LOCK .43	4
24		600760	.. TERM,FRICT 250X032 UNINSUL MALE .130 STUD MTG 1PR	1

+When ordering a component originally displaying a precautionary label, the label should also be ordered.

To maintain the factory original performance of your equipment, use only Manufacturer's Suggested Replacement Parts. Model and serial number required when ordering parts from your local distributor.

 Hardware is common and not available unless listed.

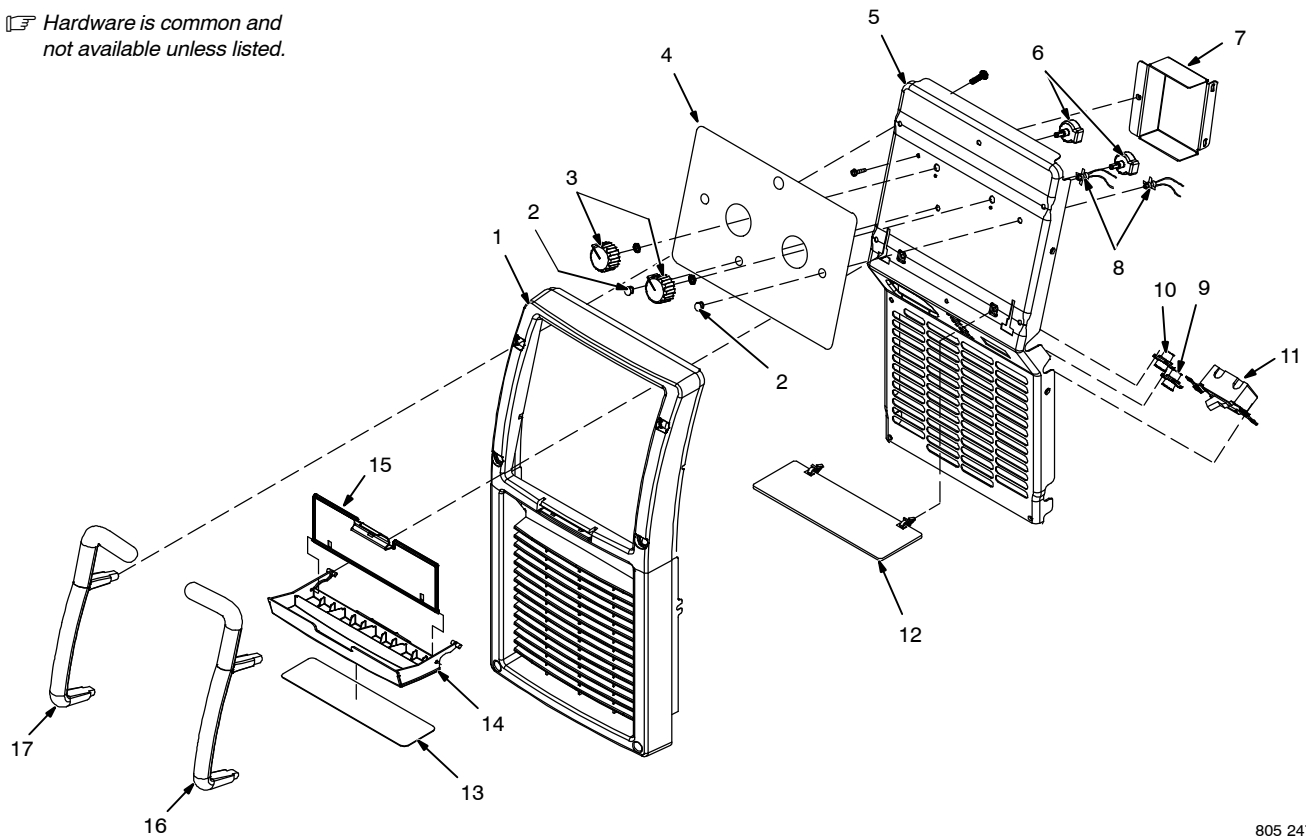

805 247-A

Figure 9-3. Panel, Front w/Components

Item No.	Dia. Mkgs.	Part No.	Description	Quantity
----------	------------	----------	-------------	----------

Figure 9-3. Panel, Front w/Components

...	1	230304	.. BEZEL,FRONT W/CONSUMABLE TRAY	1
.....		226660	.. LABEL,POWER/MIG GUN/SPOOLGUN	1
...	2	159036	.. LENS,LED CLEAR PANEL MTG	2
...	3	238122	.. KNOB,POINTER 1.625 DIA	2
...	4	248456	.. LABEL,CONTROLS (Eff w/MA440832N)	1
...	4	237436	.. LABEL,CONTROLS (Prior to MA440832N)	1
...	5	248495	.. PANEL,FRONT (Eff w/MA440832N)	1
...	5	238078	.. PANEL,FRONT (Prior to MA440832N)	1
...	6	R1,R2 . 238100	.. POT ASSY,W/LEADS &CONNECTOR CP FLAT 1T 2. W (Prior to MA290011N)	2
...	6	R1,R2 . 246617	.. POT ASSY,W/LEADS &CONNECTOR CP FLAT 1T 2. W 1K OHM LINEAR (DUAL) (Eff w/MA290011N)	2
...	7	238079	.. ENCLOSURE,PC BOARD/POTS	1
...	8	LED1,2,3 248259	.. LED ASSY,W/LEADS (Eff w/MA440832N)	1
...	8	LED1,2 238101	.. LED ASSY,W/LEADS (Prior to MA440832N)	1
...	9	RC1 .. 048282	.. RCPT W/SKTS,(SERVICE KIT) (MIG GUN)	1
...	10	RC2 .. 190363	.. RCPT W/SKTS,(SERVICE KIT) (SPOOL GUN)	1
...	11	S1 .. 124511	.. SWITCH,TGL DPST 40A 600VAC SCR TERM	1
...	12	238124	.. FLIP CHART	1
.....		230365	.. CLIP,SNAP IN .250ID X .250 MT HOLE X .030-.125 PNL	2
...	13	238114	.. LABEL,NAMEPLATE	1
...	14	229617	.. TRAY,CONSUMABLES	1
...	15	229618	.. COVER,TRAY CONSUMABLES	1
.....		226653	.. LABEL,CONSUMABLES M25	1
...	16	231553	.. HANDLE,RH	1
...	17	231554	.. HANDLE,LH	1

+When ordering a component originally displaying a precautionary label, the label should also be ordered.

To maintain the factory original performance of your equipment, use only Manufacturer's Suggested Replacement Parts. Model and serial number required when ordering parts from your local distributor.

☞ Hardware is common and not available unless listed.

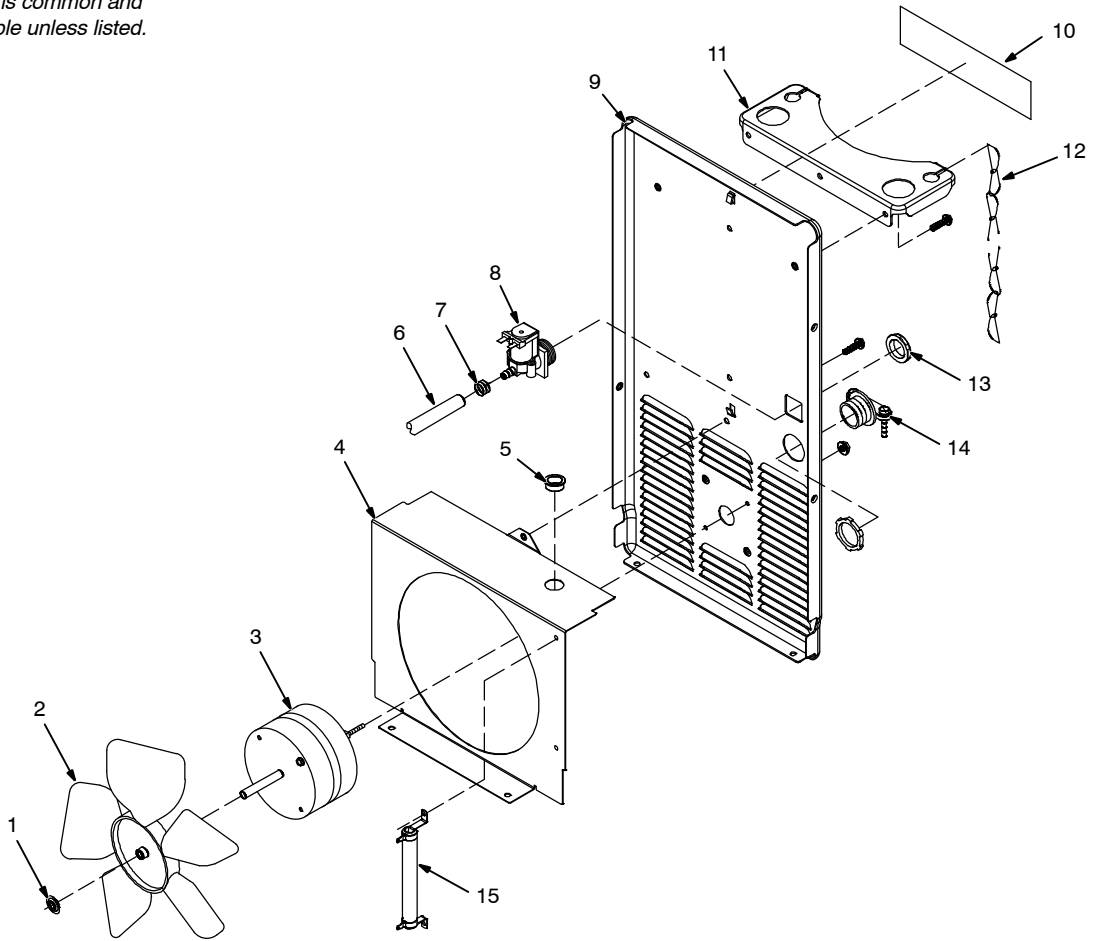

805 248-A

Figure 9-4. Panel, Rear w/Components

Item No.	Dia. Mkgs.	Part No.	Description	Quantity
----------	------------	----------	-------------	----------

Figure 9-4. Panel, Rear w/Components

...	1	049399	.. NUT, 312-18 PUSH ON .63D .07H STL	1
...	2	148809	.. BLADE,FAN 9.000 5WG 34DEG .312 BORE CCW PLSTC	1
...	3	FM 188706	.. MOTOR,FAN 230V 50/60HZ 1550 RPM .312 DIA SHAFT	1
...	4	225669	.. WINDTUNNEL,	1
...	5	010493	.. BUSHING,SNAP-IN NYL .625 ID X .875 MTG HOLE	1
...	6	146524	.. HOSE,SAE .187 ID X .410 OD X 27.000	1
...	7	149332	.. CLAMP,HOSE .405 - .485 CLP DIA SLFTTNG OLIVE DRA	2
...	8	GS1 228035	.. VALVE, 34VDC 1WAY .750-14 THD 2MM ORF 100PSI	1
...	9	+225282	.. PANEL,REAR	1
...	10	231986	.. LABEL,WARNING CYL MAY EXPLODE IF DAMAGED (EN/SP)	1
...	11	229628	.. BRACKET,SUPPORT CYLINDER	1
...	12	188441	.. CHAIN,WELDLESS 2/0 X 31. BRIGHT ZINC PLD	1
...	13	220805	.. NUT, 750-14 NPS 1.48HEX .41H NYL	1
...	14	604102	.. CONN,CLAMP CABLE 1.000	1
...	15	R1 091685	.. RESISTOR,WW FXD 50 W 25 OHM FASTON TE	1

+When ordering a component originally displaying a precautionary label, the label should also be ordered.

To maintain the factory original performance of your equipment, use only Manufacturer's Suggested Replacement Parts. Model and serial number required when ordering parts from your local distributor.

**See Section 1-1
Drive Roll & Wire Guide Kits.**

 Hardware is common and not available unless listed.

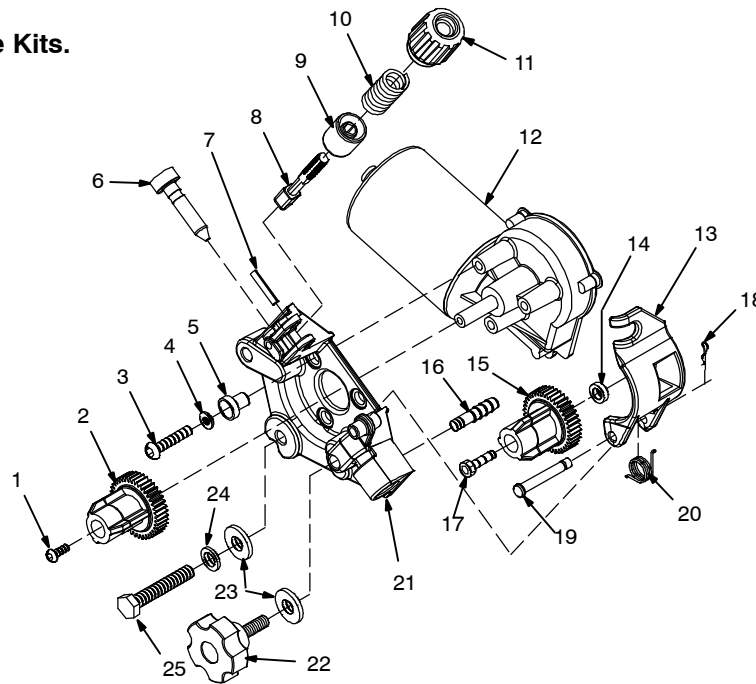

804 919-B

Figure 9-5. Wire Drive And Gears

Item No.	Dia. Mkgs.	Part No.	Description	Quantity
...	...	209079	.. SCREW,M 4- .7X 16 PAN HD-PHL PLD DIN 7985	1
...	...	173619	.. CARRIER,DRIVE ROLL W/COMPONENTS 24 PITCH 10MM SHAF	1
...	...	174610	.. SCREW,M 6-1.0X 20 SOC HD BUTTON CAP BLK	3
...	...	192029	.. WASHER,FLAT .250IDX0.437ODX.015T STL PLN	3
...	...	173620	.. BUSHING,MTG MOTOR	3
...	...	221912	.. GUIDE,WIRE INLET NYLON .023 - .052	1
...	...	010224	.. PIN,SPRING CS .187 X 1.000	1
...	...	221976	.. KNOB,TENSION ADJUST ASSY (INCLUDING)	1
...	...	225718	.. FASTENER,PINNED	1
...	...	196896	.. CUP,SPRING	1
...	...	196897	.. SPRING,CPRSN .695 OD X .095 WIRE X 1.500	1
...	...	196895	.. KNOB,TENSION	1
...	M	233009	.. MOTOR,GEAR 24VDC 150RPM 37:5 RATIO	1
...	...	228828	.. LEVER,MTG PRESSURE GEAR	1
...	...	230801	.. SPRING,TORSION	1
...	...	166072	.. SPACER,GEAR	1
...	...	172075	.. CARRIER,DRIVE ROLL W/COMPONENTS 24 PITCH	1
...	...	079633	.. FTG,HOSE BRS BARBED NIPPLE 3/16 TBG	1
...	...	602009	.. SCREW,250-20X1.25 SOC HD-HEX GR8 PLN	1
...	...	151828	.. PIN,COTTER HAIR .042 X .750	1
...	...	234784	.. PIN,CLEVIS .250 OD X 1.751 LG W/GROOVE	1
...	...	230801	.. SPRING,TORSION	1
...	...	228826	.. HOUSING,ADAPTER DRIVE MOTOR	1
...	...	204585	.. KNOB,FLUTED 1.75 IN W/ .312-18 STUD 1.00 LG	1
...	...	604538	.. WASHER,FLAT .344IDX0.688ODX.065T STL PLD ANSI.312	2
...	...	602211	.. WASHER,LOCK .318IDX0.586ODX.078T STL PLD SPLIT.312	2
...	...	604534	.. SCREW,312-18X1.25 HEX HD-PLN GR5 PLD	1
...	...	203526	.. ROLL,DRIVE V GROOVE .030-.035 WIRE	2

*Recommended Spare Parts.

To maintain the factory original performance of your equipment, use only Manufacturer's Suggested Replacement Parts. Model and serial number required when ordering parts from your local distributor.

1-1. Drive Roll And Wire Guide Kits

☞ Base selection of drive rolls upon the following recommended usages:

- 1 V-Grooved rolls for hard wire (olid steel and metal cored).
- 2 U-Grooved rolls for soft and soft shelled cored wires (aluminum).
- 3 U-Cogged rolls for extremely soft shelled wires (usually hard surfacing types).
- 4 V-Knurled rolls for hard shelled cored wires (flux cored).
- 5 Drive roll types may be mixed to suit particular requirements (example: V-Knurled roll in combination with U-Grooved).

Wire Diameter			Kit No.	Drive Roll		Inlet Wire Guide
Fraction	Decimal	Metric		Part No.	Type	
.023/.025 in.	.023/.025 in.	0.6 mm	087 131	087 130	V-Grooved	056 192
.030/.035 in.	.030/.035 in.	0.8/0.9 mm	204 579	203 526	V-Grooved	056 192
.030 in.	.030 in.	0.8 mm	079 594	053 695	V-Grooved	056 192
.035 in.	.035 in.	0.9 mm	079 595	053 700	V-Grooved	056 192
.045 in.	.045 in.	1.2 mm	079 596	053 697	V-Grooved	056 193

Ref. S-0026-B/7-91

Miller Electric Mfg. Co.

An Illinois Tool Works Company
1635 West Spencer Street
Appleton, WI 54914 USA

International Headquarters—USA

USA Phone: 920-735-4505 Auto-Attended
USA & Canada FAX: 920-735-4134
International FAX: 920-735-4125

For International Locations Visit
www.MillerWelds.com

