

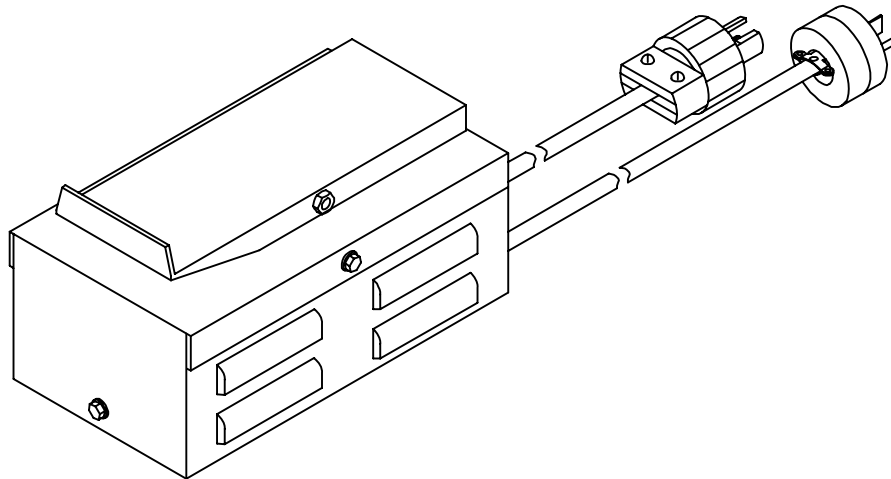

March 1991

FORM: OM-826G

**MODEL: RFC-14
RFC-23A
RFC-23AG
RFCS-23
RFC-23GD25A**



OWNER'S MANUAL

IMPORTANT: Read and understand the entire contents of this manual, with special emphasis on the safety material throughout the manual, before installing, operating, or maintaining this equipment. This unit and these instructions are for use only by persons trained and experienced in the safe operation of welding equipment. Do not allow untrained persons to install, operate, or maintain this unit. Contact your distributor if you do not fully understand these instructions.

MILLER ELECTRIC Mfg. Co.
A Miller Group Ltd., Company

P.O. Box 1079
Appleton, WI 54912 USA
Tel. 414-734-9821

LIMITED WARRANTY

EFFECTIVE: MARCH 15, 1989

This warranty supersedes all previous MILLER warranties and is exclusive with no other guarantees or warranties expressed or implied.

LIMITED WARRANTY – Subject to the terms and conditions hereof, Miller Electric Mfg. Co., Appleton, Wisconsin warrants to its Distributor/Dealer that all new and unused Equipment furnished by Miller is free from defect in workmanship and material as of the time and place of delivery by Miller. No warranty is made by Miller with respect to engines, trade accessories or other items manufactured by others. Such engines, trade accessories and other items are sold subject to the warranties of their respective manufacturers, if any. All engines are warranted by their manufacturer for one year from date of original purchase, except Tecumseh and Onan engines which have a two year warranty.

Except as specified below, Miller's warranty does not apply to components having normal useful life of less than one (1) year, such as spot welder tips, relay and contactor points, MILLER-MATIC parts that come in contact with the welding wire including nozzles and nozzle insulators where failure does not result from defect in workmanship or material.

Miller shall be required to honor warranty claims on warranted Equipment in the event of failure resulting from a defect within the following periods from the date of delivery of Equipment to the original user:

1. Arc welders, power sources, robots, and 1 year components
2. Load banks 1 year
3. Original main power rectifiers 3 years (labor – 1 year only)
4. All welding guns, feeder/guns and torches 90 days
5. All other Millermatic Feeders 1 year
6. Replacement or repair parts, exclusive of labor .. 60 days
7. Batteries 6 months

provided that Miller is notified in writing within thirty (30) days of the date of such failure.

As a matter of general policy only, Miller may honor claims submitted by the original user within the foregoing periods.

In the case of Miller's breach of warranty or any other duty with respect to the quality of any goods, the exclusive remedies therefore shall be, at Miller's option (1) repair or (2) replacement or, where authorized in writing by Miller in appropriate cases, (3) the reasonable cost of repair or replacement at an authorized Miller service station or (4) payment of or credit for the purchase price (less reasonable depreciation based upon actual use) upon return of the goods at Customer's risk and expense. MILLER's option of repair or replacement will be F.O.B., Factory at Appleton, Wisconsin, or F.O.B. at a MILLER authorized service facility, therefore, no compensation for transportation costs of any kind will be allowed. Upon receipt of notice of apparent defect or failure, Miller shall instruct the claimant on the warranty claim procedures to be followed.

ANY EXPRESS WARRANTY NOT PROVIDED HEREIN AND ANY IMPLIED WARRANTY, GUARANTY OR REPRESENTATION AS TO PERFORMANCE, AND ANY REMEDY FOR BREACH OF CONTRACT WHICH, BUT FOR THIS PROVISION, MIGHT ARISE BY IMPLICATION, OPERATION OF LAW, CUSTOM OF TRADE OR COURSE OF DEALING, INCLUDING ANY IMPLIED WARRANTY OF MERCHANTABILITY OR OF FITNESS FOR PARTICULAR PURPOSE, WITH RESPECT TO ANY AND ALL EQUIPMENT FURNISHED BY MILLER IS EXCLUDED AND DISCLAIMED BY MILLER.

EXCEPT AS EXPRESSLY PROVIDED BY MILLER IN WRITING, MILLER PRODUCTS ARE INTENDED FOR ULTIMATE PURCHASE BY COMMERCIAL/INDUSTRIAL USERS AND FOR OPERATION BY PERSONS TRAINED AND EXPERIENCED IN THE USE AND MAINTENANCE OF WELDING EQUIPMENT AND NOT FOR CONSUMERS OR CONSUMER USE. MILLER'S WARRANTIES DO NOT EXTEND TO, AND NO RESELLER IS AUTHORIZED TO EXTEND MILLER'S WARRANTIES TO, ANY CONSUMER.

RECEIVING-HANDLING

Before unpacking equipment, check carton for any damage that may have occurred during shipment. File any claims for loss or damage **with the delivering carrier**. Assistance for filing or settling claims may be obtained from the distributor and/or the equipment manufacturer's Transportation Department.

When requesting information about this equipment, always provide the Model Description and Serial or Style Number.

Use the following spaces to record the Model Designation and Serial or Style Number of your unit. The information is located on the data card or the nameplate.

Model _____

Serial or Style No. _____

Date of Purchase _____

SECTION 1 – INTRODUCTION

1-1. GENERAL INFORMATION AND SAFETY

A. General

Information presented in this manual and on various labels, tags, and plates provided on this unit pertains to equipment design, installation, operation, maintenance, and troubleshooting which should be read, understood, and followed for the safe and effective use of this equipment.

B. Safety

The installation, operation, maintenance, and troubleshooting of arc welding equipment requires practices and procedures which ensure personal safety and the safety of others. Therefore, this equipment is to be installed, operated, and maintained only by qualified persons in accordance with this manual and all applicable codes such as, but not limited to, those listed at the end of Section 1 – Safety Rules For Operation Of Arc Welding Power Source in the welding power source Owner's Manual.

Safety instructions specifically pertaining to this unit appear throughout this manual highlighted by the signal words **WARNING** and **CAUTION** which identify different levels of hazard.

WARNING statements include installation, operation, and maintenance procedures or practices which if not carefully followed could result in serious personal injury or loss of life.

CAUTION statements include installation, operation, and maintenance procedures or practices which if not carefully followed could result in minor personal injury or damage to this equipment.

A third signal word, **IMPORTANT**, highlights instructions which need special emphasis to obtain the most efficient operation of this equipment.

1-2. DESCRIPTION

These Remote Foot Controls are designed for use as a remote Amperage or Voltage control in conjunction with a welding power source or welding generator having electric amperage or voltage control and equipped with remote control facilities. Some models of the Remote Foot Control have an additional feature of remote contactor control. They are identified by the appearance of the number 23 in the model description. Those Remote Foot Controls with the letters GD displayed in the model description are designed for use with welding generators only.

SECTION 2 – INSTALLATION

2-1. LOCATION

The Remote Foot Control is equipped with a twenty foot cord (unless otherwise specified) which enables the Remote Foot Control to be remotely located from the welding power source or welding generator.

If it is necessary to install a cord of longer length, up to 200 feet (61 m) of similar type cord may be used. Refer to Table 2-1 for conductor size according to the desired length.

2-2. INTERCONNECTIONS

A. Remote Foot Controls For Remote Amperage Or Voltage Control Only

1. If the cord is equipped with a locking cap, fully insert

the cap into the Remote Amperage or Voltage Control Receptacle on the welding power source or welding generator and rotate clockwise.

2. If the cord is equipped with a power connector, align keyway, insert plug into receptacle, and rotate threaded collar fully clockwise.

B. Remote Foot Controls For Remote Amperage Or Voltage Control And Remote Contactor Control

Fully insert the locking caps that are attached to the cords into their corresponding receptacles on the welding power source or welding generator and rotate clockwise.

Table 2-1. Cord Length And Size

Amperage or Voltage Control		Contactor Control	
Cord Length	Conductor Size*	Cord Length	Conductor Size
Up To 20 Feet (6 m) Up To 20 Feet (6 m) (GD Models) 21 To 100 Feet (6 to 30 m) (GD Models) 21 To 50 Feet (6 to 15 m) 51 To 100 Feet (16 to 31 m) 101 To 200 Feet (31 to 61 m)	No. 16 No. 14 No. 12 No. 14 No. 12 No. 10	Up To 200 Feet (61 m)	No. 16

*AWG – American Wire Gauge

SECTION 3 – OPERATOR CONTROLS

3-1. REMOTE AMPERAGE OR VOLTAGE CONTROL

On most welding power sources or welding generators, when a Remote Foot Control is used, the Remote Foot Control functions as a fine amperage or voltage adjustment of the Amperage or Voltage Adjustment Control setting on the welding power source or welding generator. For example: If the Amperage or Voltage Adjustment Control on the welding power source or welding generator is set at the mid-point position, the Remote Foot Control provides (from its minimum to maximum positions) fine adjustment of one half of the welding power source or welding generator output. If full adjustment of the maximum output of the welding power source or welding generator from the Remote Foot Control is desired, rotate the Amperage or Voltage Adjustment Control on the welding power source or welding generator to the maximum position.

On some welding power sources or welding generators the Amperage or Voltage Adjustment Control is inoperative when a Remote Foot Control is used. In this case, the Remote Foot Control provides complete control from the minimum to the maximum output of the welding power source or welding generator rather than fine adjustment of the Amperage or Voltage Adjustment Control setting on the welding power source or welding generator.

control setting on the welding power source or welding generator.

To determine in which way the Remote Foot Control affects the operation of the welding power source or welding generator, refer to the the welding power source or welding generator circuit diagram and/or Instruction Manual.

3-2. REMOTE CONTACTOR CONTROL AND REMOTE AMPERAGE OR VOLTAGE CONTROL

When a Remote Foot Control is used for both remote contactor control and remote amperage or voltage control, the Remote Foot Control has a switch for on-off control of the contactor in the welding power source or welding generator, as well as a remote amperage or voltage control. Pressing the Remote Foot Control pedal downward closes the contactor control switch and open-circuit voltage is available at the output terminals. Pressing the pedal down further provides remote amperage or voltage control (see Section 3-1).

IMPORTANT: *When a Remote Foot Control is used, refer to the Instruction Manual of the welding power source or welding generator for additional operational information.*

SECTION 4 – MAINTENANCE



WARNING: ELECTRIC SHOCK can kill; HOT SURFACES can cause severe burns.

- *Do not touch live electrical parts.*
- *Disconnect plugs from power source before inspecting or servicing.*
- *Allow unit to cool before servicing.*

Once each month inspect the Remote Foot Control Cord for breaks in the insulating jacket particularly at the plug and at the entrance into the Remote Foot Control

housing. Repair all breaks with electrical tape, or replace the cord if necessary. Refer to Table 2-1 for proper cord conductor size and to Diagram 5-1 through Diagram 5-4 for proper cord conductor connections).

Daily, move the Remote Foot Control foot pedal from the minimum to the maximum position. This procedure will prevent oxidation from building on the contacts, which could insulate the contacts from the brush, causing the control to become inoperative.

SECTION 5 – ELECTRICAL DIAGRAMS

Circuit Diagram No. CA-040 071-1

Diagram 5-1. Circuit Diagram For RFC-23A

Circuit Diagram No. CA-041 161-1A

Diagram 5-2. Circuit Diagram For RFC-23AG

Circuit Diagram No. CA-041 148-1A1

Diagram 5-3. Circuit Diagram For RFCS-23

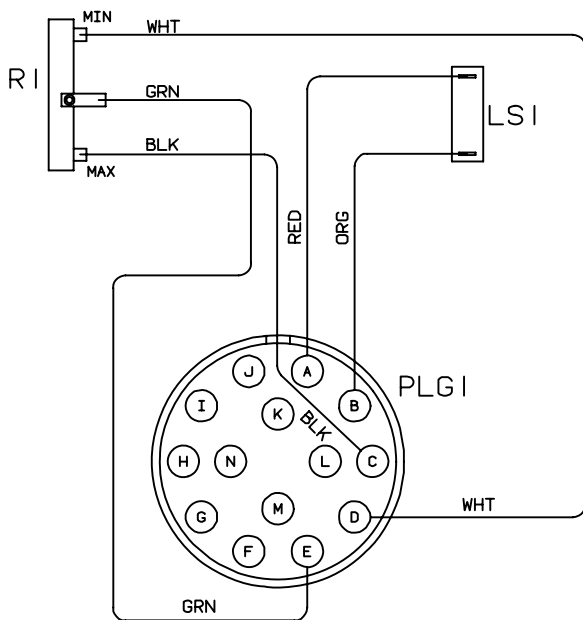

Wiring Diagram No. SA-130 512

Circuit Diagram No. CA-004 737-1A

Diagram 5-4. Circuit Diagram For RFC-23GD25A

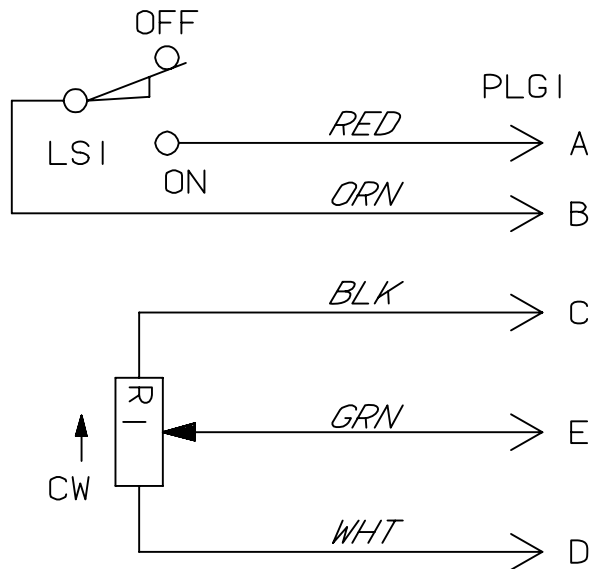

Circuit Diagram No. SA-130 542

Diagram 5-5. Wiring And Circuit Diagram For RFC-14

SECTION 6 – PARTS LIST

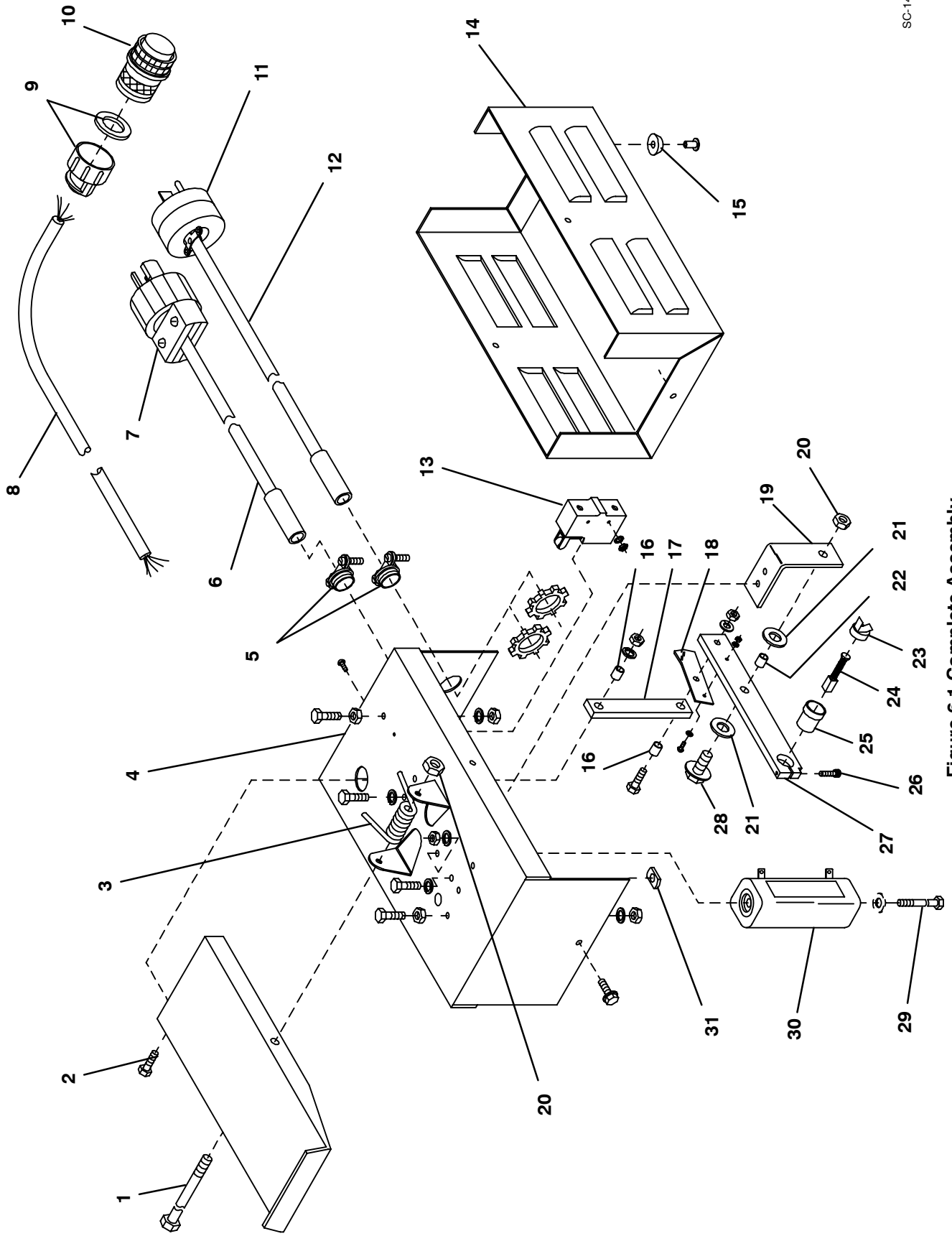

Figure 6.1 Complete Assembly

Item No.	Part No.	Description	Quantity				
Figure 6-1. Complete Assembly			RFC-23A	RFC-23AG	RFC-14	RFC-23GD25A	RFCS-23
1	601 970	SCREW, cap stl hex hd .375-24 x 4.500	1	1	1	1	1
2	019 662	PEDAL, foot	1	1	1		1
2	090 490	PEDAL, foot				1	
3	010 789	SPRING, torsion	1	1	1	1	1
4	+137 240	CASE SECTION, cover/end	1	1	1		1
4	+138 305	CASE SECTION, cover/end				1	
	085 220	LABEL, caution electric circuit etc	1	1	1	1	1
5	115 104	CONNECTOR, clp - cable .500	2	2		1	
5	138 262	STRAIN RELIEF, cable flexible .428-.546			1		1
5	137 826	STRAIN RELIEF, cable flexible .354-.629				1	
	137 761	NUT, nyl lock .750NPT				1	
6	053 786	CORD SET, pwr 115V 16ga 2/c 20ft	1				
6	136 823	CORD SET, pwr 115V 16ga 2/c				1	
7	039 618	PLUG, twlk 2P 2W 20A 250V	1			1	
7	035 494	PLUG, twlk grd 2P 3W 15A 250V		1			
8	600 343	CABLE, port No 16 5/c (order by ft)			20ft		21ft
9	039 685	CLAMP, cable AN-3057-8					1
9	079 739	CLAMP, cable strain relief			1		
10	039 273	PLUG, 5 pin MS3106A-16S-8P					1
10	141 162	HOUSING PLUG & PINS, (consisting of)			1		
	134 731	· TERMINAL, male 1 pin 18-14 wire			14		
11	605 797	PLUG, twlk 3P 3W 20A 125V	1	1			
11	039 621	PLUG, twlk 4P 4W 20A 250V				1	
12	600 733	CORD SET, pwr 115V 16ga 3/c 20ft	1	1			
12	604 834	CORD, port No 14 4/c (order by ft)				26ft	
13	011 628	SWITCH, limit 15A 125V	1	1	1		1
13	603 947	SWITCH, limit 10A 125V				1	
	602 192	WASHER, fbr .187 ID x .500 OD x .062thk	2	2	2		2
14	014 920	CASE SECTION, base/side	1	1	1	1	1
15	019 663	MOUNT, nprn	4	4	4	4	4
16	600 176	BUSHING, stl .260 ID x .375 OD x .390 lg	2	2	2	2	2
17	017 360	BAR, pedal - control foot	1	1	1	1	1
18	010 795	ACTUATOR, switch - limit	1	1	1	1	1
19	010 794	BRACKET, support - arm	1	1	1	1	1
20	601 850	NUT, stl slflkg hex .375-24	2	2	2	2	2
	602 212	WASHER, lock stl intl tooth .312	1	1			
21	010 652	BEARING, thr .500 ID x 1.000 OD x .062	2	2	2	2	2
22	024 660	BUSHING, slv .375 x .500 x .375	1	1	1	1	1
23	047 885	CAP, brush holder	1	1	1	1	1
24	*018 640	BRUSH, contact	1	1	1	1	1
25	018 639	HOLDER, brush	1	1	1	1	1
26	604 432	SCREW, cap stl sch 8-32 x 1.000	1	1	1	1	1
27	010 793	ARM, brush holder	1	1	1	1	1
28	602 186	BOLT, mach stl hexwhd .375-24 x 1.000	1	1	1	1	1
29	601 795	BOLT, mach stl hexhd .250-20 x 4.500	1	1	1	2	1
30	030 631	RESISTOR, WW adj 130W 15 ohm	1	1			
30	030 051	RESISTOR, WW adj 130W 1000 ohm			1		1
30	004 652	RESISTOR, WW adj 300W 25 ohm				1	
31	601 855	NUT, weld .250-20	1	1	1	1	1
		NAMEPLATE (order by model number)	1	1			

+When ordering a component originally displaying a precautionary label, the label should also be ordered.
BE SURE TO PROVIDE MODEL AND SERIAL NUMBER WHEN ORDERING REPLACEMENT PARTS.