



OM-611

096 556L

September 2000

Processes



TIG (GTAW) Welding

Description

High Frequency Arc Starter

HF-251D-1 And HF-251-2

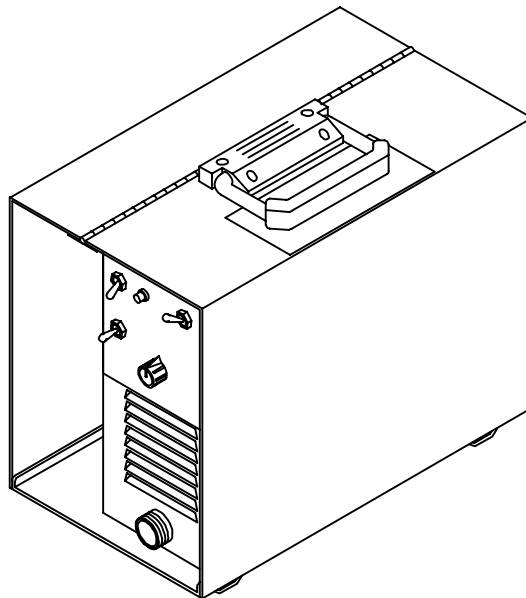

OWNER'S MANUAL



Visit our website at
www.MillerWelds.com

From Miller to You

Thank you and congratulations on choosing Miller. Now you can get the job done and get it done right. We know you don't have time to do it any other way.

That's why when Niels Miller first started building arc welders in 1929, he made sure his products offered long-lasting value and superior quality. Like you, his customers couldn't afford anything less. Miller products had to be more than the best they could be. They had to be the best you could buy.



Today, the people that build and sell Miller products continue the tradition. They're just as committed to providing equipment and service that meets the high standards of quality and value established in 1929.

This Owner's Manual is designed to help you get the most out of your Miller products. Please take time to read the Safety precautions. They will help you protect yourself against potential hazards on the worksite. We've

made installation and operation quick and easy. With Miller you can count on years of reliable service with proper maintenance. And if for some reason the unit needs repair, there's a Troubleshooting section that will help you figure out what the problem is. The parts list will then help you to decide which exact part you may need to fix the problem. Warranty and service information for your particular model are also provided.



Miller is the first welding equipment manufacturer in the U.S.A. to be registered to the ISO 9001 Quality System Standard.

Miller Electric manufactures a full line of welders and welding related equipment. For information on other quality Miller products, contact your local Miller distributor to receive the latest full line catalog or individual catalog sheets. **To locate your nearest distributor or service agency call 1-800-4-A-Miller, or visit us at www.MillerWelds.com on the web.**



Working as hard as you do – every power source from Miller is backed by the most hassle-free warranty in the business.

Miller offers a Technical Manual which provides more detailed service and parts information for your unit. To obtain a Technical Manual, contact your local distributor. Your distributor can also supply you with Welding Process Manuals such as SMAW, GTAW, GMAW, and GMAW-P.



TABLE OF CONTENTS

WARNING

This product, when used for welding or cutting, produces fumes or gases which contain chemicals known to the State of California to cause birth defects and, in some cases, cancer. (California Health & Safety Code Section 25249.5 et seq.)

SECTION 1 – SAFETY PRECAUTIONS - READ BEFORE USING	1
1-1. Symbol Usage	1
1-2. Arc Welding Hazards	1
1-3. Additional Symbols for Installation, Operation, and Maintenance	3
1-4. Principal Safety Standards	3
1-5. EMF Information	4
SECTION 1 – CONSIGNES DE SECURITE – LIRE AVANT UTILISATION	5
1-1. Signification des symboles	5
1-2. Dangers relatifs au soudage à l'arc	5
1-3. Dangers supplémentaires en relation avec l'installation, le fonctionnement et la maintenance	7
1-4. Principales normes de sécurité	8
1-5. Information sur les champs électromagnétiques	8
2-1. Specifications	1
SECTION 2 – INSTALLATION	9
2-1. Specifications	9
2-2. Typical Process Connections	9
2-3. Installing Gas Supply	10
2-4. Power Source Plug Information And Connections	11
2-5. Operator Control Receptacle Information And Connections	12
2-6. Operator Control Receptacle Socket Information	12
2-7. Connecting To Weld Output Terminals	13
2-8. Connecting Input Power	14
SECTION 3 – OPERATION	15
3-1. Controls	15
3-2. High Frequency Switch	15
3-3. High Frequency Selector Switch	15
3-4. High Frequency Intensity Control	16
3-5. Power Switch And Pilot Light	16
3-6. Postflow Timer	16
3-7. Shielding Gas	16
SECTION 4 – MAINTENANCE & TROUBLESHOOTING	17
4-1. Routine Maintenance	17
4-2. Adjusting Spark Gaps	18
4-3. Troubleshooting	19
SECTION 5 – ELECTRICAL DIAGRAMS	20
SECTION 6 – SELECTING AND PREPARING TUNGSTEN ELECTRODE	21
6-1. Selecting Tungsten Electrode	21
6-2. Preparing Tungsten For AC Or DC Electrode Positive (DCEP) Welding	22
6-3. Preparing Tungsten For DC Electrode Negative (DCEN) Welding	22
SECTION 7 – GUIDELINES FOR TIG WELDING (GTAW)	23
7-1. Positioning The Torch	23
7-2. Torch Movement During Welding	23
7-3. Positioning Torch Tungsten For Various Weld Joints	24
SECTION 8 – HIGH FREQUENCY	25
8-1. Welding Processes Requiring High Frequency	25
8-2. Incorrect Installation	25
8-3. Correct Installation	26
SECTION 9 – PARTS LIST	28
OPTIONS AND ACCESSORIES	
WARRANTY	

The following terms are used interchangeably throughout this manual:
TIG = GTAW
Stick = SMAW

SECTION 1 – SAFETY PRECAUTIONS - READ BEFORE USING

som_nd_4/98

1-1. Symbol Usage



Means Warning! Watch Out! There are possible hazards with this procedure! The possible hazards are shown in the adjoining symbols.

▲ Marks a special safety message.

☞ Means "Note"; not safety related.



This group of symbols means Warning! Watch Out! possible ELECTRIC SHOCK, MOVING PARTS, and HOT PARTS hazards. Consult symbols and related instructions below for necessary actions to avoid the hazards.

1-2. Arc Welding Hazards

▲ The symbols shown below are used throughout this manual to call attention to and identify possible hazards. When you see the symbol, watch out, and follow the related instructions to avoid the hazard. The safety information given below is only a summary of the more complete safety information found in the Safety Standards listed in Section 1-4. Read and follow all Safety Standards.

▲ Only qualified persons should install, operate, maintain, and repair this unit.

▲ During operation, keep everybody, especially children, away.



ELECTRIC SHOCK can kill.

Touching live electrical parts can cause fatal shocks or severe burns. The electrode and work circuit is electrically live whenever the output is on. The input power circuit and machine internal circuits are also

live when power is on. In semiautomatic or automatic wire welding, the wire, wire reel, drive roll housing, and all metal parts touching the welding wire are electrically live. Incorrectly installed or improperly grounded equipment is a hazard.

- Do not touch live electrical parts.
- Wear dry, hole-free insulating gloves and body protection.
- Insulate yourself from work and ground using dry insulating mats or covers big enough to prevent any physical contact with the work or ground.
- Do not use AC output in damp areas, if movement is confined, or if there is a danger of falling.
- Use AC output ONLY if required for the welding process.
- If AC output is required, use remote output control if present on unit.
- Disconnect input power or stop engine before installing or servicing this equipment. Lockout/tagout input power according to OSHA 29 CFR 1910.147 (see Safety Standards).
- Properly install and ground this equipment according to its Owner's Manual and national, state, and local codes.
- Always verify the supply ground – check and be sure that input power cord ground wire is properly connected to ground terminal in disconnect box or that cord plug is connected to a properly grounded receptacle outlet.
- When making input connections, attach proper grounding conductor first – double-check connections.
- Frequently inspect input power cord for damage or bare wiring – replace cord immediately if damaged – bare wiring can kill.
- Turn off all equipment when not in use.
- Do not use worn, damaged, undersized, or poorly spliced cables.
- Do not drape cables over your body.

- If earth grounding of the workpiece is required, ground it directly with a separate cable.
- Do not touch electrode if you are in contact with the work, ground, or another electrode from a different machine.
- Use only well-maintained equipment. Repair or replace damaged parts at once. Maintain unit according to manual.
- Wear a safety harness if working above floor level.
- Keep all panels and covers securely in place.
- Clamp work cable with good metal-to-metal contact to workpiece or worktable as near the weld as practical.
- Insulate work clamp when not connected to workpiece to prevent contact with any metal object.
- Do not connect more than one electrode or work cable to any single weld output terminal.

SIGNIFICANT DC VOLTAGE exists after removal of input power on inverters.

- Turn Off inverter, disconnect input power, and discharge input capacitors according to instructions in Maintenance Section before touching any parts.

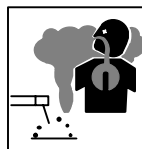

FUMES AND GASES can be hazardous.

Welding produces fumes and gases. Breathing these fumes and gases can be hazardous to your health.

- Keep your head out of the fumes. Do not breathe the fumes.
- If inside, ventilate the area and/or use exhaust at the arc to remove welding fumes and gases.
- If ventilation is poor, use an approved air-supplied respirator.
- Read the Material Safety Data Sheets (MSDSs) and the manufacturer's instructions for metals, consumables, coatings, cleaners, and degreasers.
- Work in a confined space only if it is well ventilated, or while wearing an air-supplied respirator. Always have a trained watch-person nearby. Welding fumes and gases can displace air and lower the oxygen level causing injury or death. Be sure the breathing air is safe.
- Do not weld in locations near degreasing, cleaning, or spraying operations. The heat and rays of the arc can react with vapors to form highly toxic and irritating gases.
- Do not weld on coated metals, such as galvanized, lead, or cadmium plated steel, unless the coating is removed from the weld area, the area is well ventilated, and if necessary, while wearing an air-supplied respirator. The coatings and any metals containing these elements can give off toxic fumes if welded.



ARC RAYS can burn eyes and skin.

Arc rays from the welding process produce intense visible and invisible (ultraviolet and infrared) rays that can burn eyes and skin. Sparks fly off from the weld.

- Wear a welding helmet fitted with a proper shade of filter to protect your face and eyes when welding or watching (see ANSI Z49.1 and Z87.1 listed in Safety Standards).
- Wear approved safety glasses with side shields under your helmet.
- Use protective screens or barriers to protect others from flash and glare; warn others not to watch the arc.
- Wear protective clothing made from durable, flame-resistant material (leather and wool) and foot protection.



WELDING can cause fire or explosion.

Welding on closed containers, such as tanks, drums, or pipes, can cause them to blow up. Sparks can fly off from the welding arc. The flying sparks, hot workpiece, and hot equipment can cause fires and burns. Accidental contact of electrode to metal objects can cause sparks, explosion, overheating, or fire. Check and be sure the area is safe before doing any welding.

- Protect yourself and others from flying sparks and hot metal.
- Do not weld where flying sparks can strike flammable material.
- Remove all flammables within 35 ft (10.7 m) of the welding arc. If this is not possible, tightly cover them with approved covers.
- Be alert that welding sparks and hot materials from welding can easily go through small cracks and openings to adjacent areas.
- Watch for fire, and keep a fire extinguisher nearby.
- Be aware that welding on a ceiling, floor, bulkhead, or partition can cause fire on the hidden side.
- Do not weld on closed containers such as tanks, drums, or pipes, unless they are properly prepared according to AWS F4.1 (see Safety Standards).
- Connect work cable to the work as close to the welding area as practical to prevent welding current from traveling long, possibly unknown paths and causing electric shock and fire hazards.
- Do not use welder to thaw frozen pipes.
- Remove stick electrode from holder or cut off welding wire at contact tip when not in use.
- Wear oil-free protective garments such as leather gloves, heavy shirt, cuffless trousers, high shoes, and a cap.
- Remove any combustibles, such as a butane lighter or matches, from your person before doing any welding.

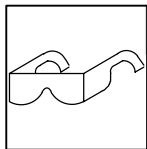

FLYING METAL can injure eyes.

- Welding, chipping, wire brushing, and grinding cause sparks and flying metal. As welds cool, they can throw off slag.
- Wear approved safety glasses with side shields even under your welding helmet.



BUILDUP OF GAS can injure or kill.

- Shut off shielding gas supply when not in use.
- Always ventilate confined spaces or use approved air-supplied respirator.

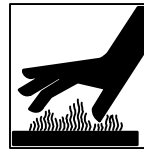

HOT PARTS can cause severe burns.

- Do not touch hot parts bare handed.
- Allow cooling period before working on gun or torch.

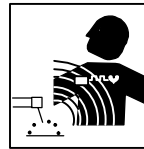

MAGNETIC FIELDS can affect pacemakers.

- Pacemaker wearers keep away.
- Wearers should consult their doctor before going near arc welding, gouging, or spot welding operations.

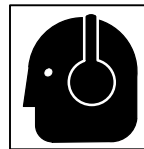

NOISE can damage hearing.

Noise from some processes or equipment can damage hearing.

- Wear approved ear protection if noise level is high.

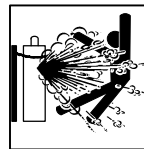

CYLINDERS can explode if damaged.

Shielding gas cylinders contain gas under high pressure. If damaged, a cylinder can explode. Since gas cylinders are normally part of the welding process, be sure to treat them carefully.

- Protect compressed gas cylinders from excessive heat, mechanical shocks, slag, open flames, sparks, and arcs.
- Install cylinders in an upright position by securing to a stationary support or cylinder rack to prevent falling or tipping.
- Keep cylinders away from any welding or other electrical circuits.
- Never drape a welding torch over a gas cylinder.
- Never allow a welding electrode to touch any cylinder.
- Never weld on a pressurized cylinder – explosion will result.
- Use only correct shielding gas cylinders, regulators, hoses, and fittings designed for the specific application; maintain them and associated parts in good condition.
- Turn face away from valve outlet when opening cylinder valve.
- Keep protective cap in place over valve except when cylinder is in use or connected for use.
- Read and follow instructions on compressed gas cylinders, associated equipment, and CGA publication P-1 listed in Safety Standards.

1-3. Additional Symbols For Installation, Operation, And Maintenance



FIRE OR EXPLOSION hazard.

- Do not install or place unit on, over, or near combustible surfaces.
- Do not install unit near flammables.
- Do not overload building wiring – be sure power supply system is properly sized, rated, and protected to handle this unit.



MOVING PARTS can cause injury.

- Keep away from moving parts such as fans.
- Keep all doors, panels, covers, and guards closed and securely in place.



FALLING UNIT can cause injury.

- Use lifting eye to lift unit only, NOT running gear, gas cylinders, or any other accessories.
- Use equipment of adequate capacity to lift and support unit.
- If using lift forks to move unit, be sure forks are long enough to extend beyond opposite side of unit.

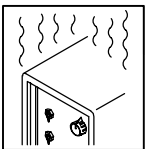

OVERUSE can cause OVERHEATING

- Allow cooling period; follow rated duty cycle.
- Reduce current or reduce duty cycle before starting to weld again.
- Do not block or filter airflow to unit.



STATIC (ESD) can damage PC boards.

- Put on grounded wrist strap BEFORE handling boards or parts.
- Use proper static-proof bags and boxes to store, move, or ship PC boards.



MOVING PARTS can cause injury.

- Keep away from moving parts.
- Keep away from pinch points such as drive rolls.



WELDING WIRE can cause injury.

- Do not press gun trigger until instructed to do so.
- Do not point gun toward any part of the body, other people, or any metal when threading welding wire.

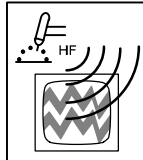

H.F. RADIATION can cause interference.

- High-frequency (H.F.) can interfere with radio navigation, safety services, computers, and communications equipment.
- Have only qualified persons familiar with electronic equipment perform this installation.
- The user is responsible for having a qualified electrician promptly correct any interference problem resulting from the installation.
- If notified by the FCC about interference, stop using the equipment at once.
- Have the installation regularly checked and maintained.
- Keep high-frequency source doors and panels tightly shut, keep spark gaps at correct setting, and use grounding and shielding to minimize the possibility of interference.

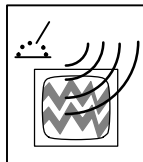

ARC WELDING can cause interference.

- Electromagnetic energy can interfere with sensitive electronic equipment such as computers and computer-driven equipment such as robots.
- Be sure all equipment in the welding area is electromagnetically compatible.
- To reduce possible interference, keep weld cables as short as possible, close together, and down low, such as on the floor.
- Locate welding operation 100 meters from any sensitive electronic equipment.
- Be sure this welding machine is installed and grounded according to this manual.
- If interference still occurs, the user must take extra measures such as moving the welding machine, using shielded cables, using line filters, or shielding the work area.

1-4. Principal Safety Standards

Safety in Welding and Cutting, ANSI Standard Z49.1, from American Welding Society, 550 N.W. LeJeune Rd, Miami FL 33126

Safety and Health Standards, OSHA 29 CFR 1910, from Superintendent of Documents, U.S. Government Printing Office, Washington, D.C. 20402.

Recommended Safe Practices for the Preparation for Welding and Cutting of Containers That Have Held Hazardous Substances, American Welding Society Standard AWS F4.1, from American Welding Society, 550 N.W. LeJeune Rd, Miami, FL 33126

National Electrical Code, NFPA Standard 70, from National Fire Protection Association, Batterymarch Park, Quincy, MA 02269.

Safe Handling of Compressed Gases in Cylinders, CGA Pamphlet P-1, from Compressed Gas Association, 1235 Jefferson Davis Highway, Suite 501, Arlington, VA 22202.

Code for Safety in Welding and Cutting, CSA Standard W117.2, from Canadian Standards Association, Standards Sales, 178 Rexdale Boulevard, Rexdale, Ontario, Canada M9W 1R3.

Safe Practices For Occupation And Educational Eye And Face Protection, ANSI Standard Z87.1, from American National Standards Institute, 1430 Broadway, New York, NY 10018.

Cutting And Welding Processes, NFPA Standard 51B, from National Fire Protection Association, Batterymarch Park, Quincy, MA 02269.

1-5. EMF Information

Considerations About Welding And The Effects Of Low Frequency Electric And Magnetic Fields

Welding current, as it flows through welding cables, will cause electromagnetic fields. There has been and still is some concern about such fields. However, after examining more than 500 studies spanning 17 years of research, a special blue ribbon committee of the National Research Council concluded that: "The body of evidence, in the committee's judgment, has not demonstrated that exposure to power-frequency electric and magnetic fields is a human-health hazard." However, studies are still going forth and evidence continues to be examined. Until the final conclusions of the research are reached, you may wish to minimize your exposure to electromagnetic fields when welding or cutting.

To reduce magnetic fields in the workplace, use the following procedures:

1. Keep cables close together by twisting or taping them.
2. Arrange cables to one side and away from the operator.
3. Do not coil or drape cables around your body.
4. Keep welding power source and cables as far away from operator as practical.
5. Connect work clamp to workpiece as close to the weld as possible.

About Pacemakers:

Pacemaker wearers consult your doctor first. If cleared by your doctor, then following the above procedures is recommended.

SECTION 1 – CONSIGNES DE SECURITE – LIRE AVANT UTILISATION

som_nd_fre 4/98

1-1. Signification des symboles



Signifie Mise en garde ! Soyez vigilant ! Cette procédure présente des risques de danger ! Ceux-ci sont identifiés par des symboles adjacents aux directives.

▲ Identifie un message de sécurité particulier.

Signifie NOTA ; n'est pas relatif à la sécurité.



Ce groupe de symboles signifie Mise en garde ! Soyez vigilant ! Il y a des risques de danger reliés aux CHOCS ÉLECTRIQUES, aux PIÈCES EN MOUVEMENT et aux PIÈCES CHAUDES. Reportez-vous aux symboles et aux directives ci-dessous afin de connaître les mesures à prendre pour éviter tout danger.

1-2. Dangers relatifs au soudage à l'arc

▲ Les symboles présentés ci-après sont utilisés tout au long du présent manuel pour attirer votre attention et identifier les risques de danger. Lorsque vous voyez un symbole, soyez vigilant et suivez les directives mentionnées afin d'éviter tout danger. Les consignes de sécurité présentées ci-après ne font que résumer l'information contenue dans les normes de sécurité énumérées à la section 1-4. Veuillez lire et respecter toutes ces normes de sécurité.

▲ L'installation, l'utilisation, l'entretien et les réparations ne doivent être confiés qu'à des personnes qualifiées.

▲ Au cours de l'utilisation, tenir toute personne à l'écart et plus particulièrement les enfants.



UN CHOC ÉLECTRIQUE peut tuer.

Un simple contact avec des pièces électriques peut provoquer une électrocution ou des blessures graves. L'électrode et le circuit de soudage sont sous tension dès que l'appareil est sur ON. Le circuit d'entrée et les circuits internes de l'appareil sont également sous tension à ce moment-là. En soudage semi-automatique ou automatique, le fil, le dévidoir, le logement des galets d'entraînement et les pièces métalliques en contact avec le fil de soudage sont sous tension. Des matériels mal installés ou mal mis à la terre présentent un danger.

- Ne jamais toucher les pièces électriques sous tension.
- Porter des gants et des vêtements de protection secs ne comportant pas de trous.
- S'isoler de la pièce et de la terre au moyen de tapis ou d'autres moyens isolants suffisamment grands pour empêcher le contact physique éventuel avec la pièce ou la terre.
- Ne pas se servir de source électrique à courant électrique dans les zones humides, dans les endroits confinés ou là où on risque de tomber.
- Se servir d'une source électrique à courant électrique UNIQUEMENT si le procédé de soudage le demande.
- Si l'utilisation d'une source électrique à courant électrique s'avère nécessaire, se servir de la fonction de télécommande si l'appareil en est équipé.
- Couper l'alimentation ou arrêter le moteur avant de procéder à l'installation, à la réparation ou à l'entretien de l'appareil. Déverrouiller l'alimentation selon la norme OSHA 29 CFR 1910.147 (voir normes de sécurité).
- Installer et mettre à la terre correctement cet appareil conformément à son manuel d'utilisation et aux codes nationaux, provinciaux et municipaux.
- Toujours vérifier la terre du cordon d'alimentation – Vérifier et s'assurer que le fil de terre du cordon d'alimentation est bien raccordé à la borne de terre du sectionneur ou que la fiche du cordon est raccordée à une prise correctement mise à la terre.
- En effectuant les raccordements d'entrée fixer d'abord le conducteur de mise à la terre approprié et contre-vérifier les connexions.
- Vérifier fréquemment le cordon d'alimentation pour voir s'il n'est pas endommagé ou dénudé – remplacer le cordon immédiatement s'il est endommagé – un câble dénudé peut provoquer une électrocution.
- Mettre l'appareil hors tension quand on ne l'utilise pas.
- Ne pas utiliser des câbles usés, endommagés, de grosseur insuffisante ou mal épissés.
- Ne pas enrouler les câbles autour du corps.
- Si la pièce soudée doit être mise à la terre, le faire directement avec un câble distinct.
- Ne pas toucher l'électrode quand on est en contact avec la pièce, la terre ou une électrode provenant d'une autre machine.

- N'utiliser qu'un matériel en bon état. Réparer ou remplacer sur-le-champ les pièces endommagées. Entretien l'appareil conformément à ce manuel.
- Porter un harnais de sécurité quand on travaille en hauteur.
- Maintenir solidement en place tous les panneaux et capots.
- Fixer le câble de retour de façon à obtenir un bon contact métal-métal avec la pièce à souder ou la table de travail, le plus près possible de la soudure.
- Isoler la pince de masse quand pas mis à la pièce pour éviter le contact avec tout objet métallique.

Il y a DU COURANT CONTINU IMPORTANT dans les convertisseurs après la suppression de l'alimentation électrique.

- Arrêter les convertisseurs, débrancher le courant électrique, et décharger les condensateurs d'alimentation selon les instructions indiquées dans la partie entretien avant de toucher les pièces.

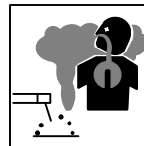

LES FUMÉES ET LES GAZ peuvent être dangereux.

Le soudage génère des fumées et des gaz. Leur inhalation peut être dangereuse pour votre santé.

- Eloigner votre tête des fumées. Ne pas respirer les fumées.
- A l'intérieur, ventiler la zone et/ou utiliser un échappement au niveau de l'arc pour l'évacuation des fumées et des gaz de soudage.
- Si la ventilation est insuffisante, utiliser un respirateur à alimentation d'air homologué.
- Lire les spécifications de sécurité des matériaux (MSDSs) et les instructions du fabricant concernant les métaux, les consommables, les revêtements, les nettoyants et les dégraissants.
- Travailler dans un espace fermé seulement s'il est bien ventilé ou en portant un respirateur à alimentation d'air. Demander toujours à un surveillant dûment formé de se tenir à proximité. Des fumées et des gaz de soudage peuvent déplacer l'air et abaisser le niveau d'oxygène provoquant des blessures ou des accidents mortels. S'assurer que l'air de respiration ne présente aucun danger.
- Ne pas souder dans des endroits situés à proximité d'opérations de dégraissage, de nettoyage ou de pulvérisation. La chaleur et les rayons de l'arc peuvent réagir en présence de vapeurs et former des gaz hautement toxiques et irritants.
- Ne pas souder des métaux munis d'un revêtement, tels que l'acier galvanisé, plaqué en plomb ou au cadmium à moins que le revêtement n'ait été enlevé dans la zone de soudure, que l'endroit soit bien ventilé, et si nécessaire, en portant un respirateur à alimentation d'air. Les revêtements et tous les métaux renfermant ces éléments peuvent dégager des fumées toxiques en cas de soudage.



LES RAYONS DE L'ARC peuvent provoquer des brûlures dans les yeux et sur la peau.

Le rayonnement de l'arc du procédé de soudage génère des rayons visibles et invisibles intenses (ultraviolets et infrarouges) susceptibles de provoquer des brûlures dans les yeux et sur la peau. Des étincelles sont projetées pendant le soudage.

- Porter un casque de soudage muni d'un écran de filtre approprié pour protéger votre visage et vos yeux pendant le soudage ou pour regarder (voir ANSI Z49.1 et Z87.1 énuméré dans les normes de sécurité).
- Porter des protections approuvés pour les oreilles si le niveau sonore est trop élevé.
- Utiliser des écrans ou des barrières pour protéger des tiers de l'éclair et de l'éblouissement; demander aux autres personnes de ne pas regarder l'arc.
- Porter des vêtements de protection constitué dans une matière durable, résistant au feu (cuir ou laine) et une protection des pieds.



LE SOUDAGE peut provoquer un incendie ou une explosion.

Le soudage effectué sur des conteneurs fermés tels que des réservoirs, tambours ou des conduites peut provoquer leur éclatement. Des étincelles peuvent être projetées de l'arc de soudure. La projection d'étincelles, des pièces chaudes et des équipements chauds peut provoquer des incendies et des brûlures. Le contact accidentel de l'électrode avec des objets métalliques peut provoquer des étincelles, une explosion, un surchauffement ou un incendie. Avant de commencer le soudage, vérifier et s'assurer que l'endroit ne présente pas de danger.

- Se protéger et d'autres personnes de la projection d'étincelles et de métal chaud.
- Ne pas souder dans un endroit là où des étincelles peuvent tomber sur des substances inflammables.
- Déplacer toutes les substances inflammables à une distance de 10,7 m de l'arc de soudage. En cas d'impossibilité les recouvrir soigneusement avec des protections homologués.
- Des étincelles et des matériaux chauds du soudage peuvent facilement passer dans d'autres zones en traversant de petites fissures et des ouvertures.
- Surveiller tout déclenchement d'incendie et tenir un extincteur à proximité.
- Le soudage effectué sur un plafond, plancher, paroi ou séparation peut déclencher un incendie de l'autre côté.
- Ne pas effectuer le soudage sur des conteneurs fermés tels que des réservoirs, tambours, ou conduites, à moins qu'ils n'aient été préparés correctement conformément à AWS F4.1 (voir les normes de sécurité).
- Brancher le câble sur la pièce le plus près possible de la zone de soudage pour éviter le transport du courant sur une longue distance par des chemins inconnus éventuels en provoquant des risques d'électrocution et d'incendie.
- Ne pas utiliser le poste de soudage pour décongeler des conduites gelées.
- En cas de non utilisation, enlever la baguette d'électrode du porte-électrode ou couper le fil à la pointe de contact.
- Porter des vêtements de protection dépourvus d'huile tels que des gants en cuir, une chemise en matériau lourd, des pantalons sans revers, des chaussures hautes et un couvre chef.
- Avant de souder, retirer toute substance combustible de vos poches telles qu'un allumeur au butane ou des allumettes.



DES PARTICULES VOLANTES peuvent blesser les yeux.

- Le soudage, l'écaillage, le passage de la pièce à la brosse en fil de fer, et le meulage génèrent des étincelles et des particules métalliques volantes. Pendant la période de refroidissement des soudures, elles risquent de projeter du laitier.
- Porter des lunettes de sécurité avec écrans latéraux ou un écran facial.



LES ACCUMULATIONS DE GAZ risquent de provoquer des blessures ou même la mort.

- Fermer l'alimentation du gaz protecteur en cas de non utilisation.
- Veiller toujours à bien aérer les espaces confinés ou se servir d'un respirateur d'adduction d'air homologué.



DES PIÈCES CHAUDES peuvent provoquer des brûlures graves.

- Ne pas toucher des parties chaudes à mains nues
- Prévoir une période de refroidissement avant d'utiliser le pistolet ou la torche.

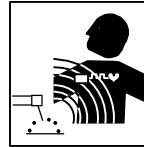

LES CHAMPS MAGNÉTIQUES peuvent affecter les stimulateurs cardiaques.

- Porteurs de stimulateur cardiaque, restez à distance.
- Les porteurs d'un stimulateur cardiaque doivent d'abord consulter leur médecin avant de s'approcher des opérations de soudage à l'arc, de gougeage ou de soudage par points.

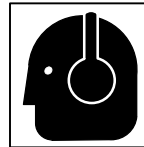

LE BRUIT peut affecter l'ouïe.

Le bruit des processus et des équipements peut affecter l'ouïe.

- Porter des protections approuvés pour les oreilles si le niveau sonore est trop élevé.

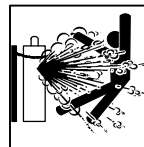

Si des BOUTEILLES sont endommagées, elles pourront exploser.

Des bouteilles de gaz protecteur contiennent du gaz sous haute pression. Si une bouteille est endommagée, elle peut exploser. Du fait que les bouteilles de gaz font normalement partie du procédé de soudage, les manipuler avec précaution.

- Protéger les bouteilles de gaz comprimé d'une chaleur excessive, des chocs mécaniques, du laitier, des flammes ouvertes, des étincelles et des arcs.
- Placer les bouteilles debout en les fixant dans un support stationnaire ou dans un porte-bouteilles pour les empêcher de tomber ou de se renverser.
- Tenir les bouteilles éloignées des circuits de soudage ou autres circuits électriques.
- Ne jamais placer une torche de soudage sur une bouteille à gaz.
- Une électrode de soudage ne doit jamais entrer en contact avec une bouteille.
- Ne jamais souder une bouteille pressurisée – risque d'explosion.
- Utiliser seulement des bouteilles de gaz protecteur, régulateurs, tuyaux et raccords convenables pour cette application spécifique; les maintenir ainsi que les éléments associés en bon état.
- Ne pas tenir la tête en face de la sortie en ouvrant la soupape de la bouteille.
- Maintenir le chapeau de protection sur la soupape, sauf en cas d'utilisation ou de branchement de la bouteille.
- Lire et suivre les instructions concernant les bouteilles de gaz comprimé, les équipements associés et les publications P-1 CGA énumérées dans les normes de sécurité.

1-3. Dangers supplémentaires en relation avec l'installation, le fonctionnement et la maintenance



Risque D'INCENDIE OU D'EXPLOSION.

- Ne pas placer l'appareil sur, au-dessus ou à proximité de surfaces inflammables.
- Ne pas installer l'appareil à proximité de produits inflammables
- Ne pas surcharger l'installation électrique – s'assurer que l'alimentation est correctement dimensionnée et protégé avant de mettre l'appareil en service.



LA CHUTE DE L'APPAREIL peut blesser.

- Utiliser l'anneau de levage uniquement pour soulever l'appareil, NON PAS les chariot, les bouteilles de gaz ou tout autre accessoire.
- Utiliser un engin d'une capacité appropriée pour soulever l'appareil.
- En utilisant des fourches de levage pour déplacer l'unité, s'assurer que les fourches sont suffisamment longues pour dépasser du côté opposé de l'appareil.

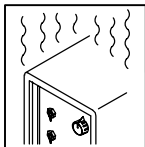

L'EMPLOI EXCESSIF peut SURCHAUFFER L'ÉQUIPEMENT.

- Prévoir une période de refroidissement, respecter le cycle opératoire nominal.
- Réduire le courant ou le cycle opératoire avant de recommencer le soudage.
- Ne pas obstruer les passages d'air du poste.

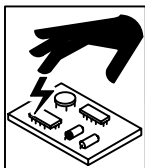

LES CHARGES ÉLECTROSTATIQUES peuvent endommager les circuits imprimés.

- Établir la connexion avec la barrette de terre avant de manipuler des cartes ou des pièces.
- Utiliser des pochettes et des boîtes antistatiques pour stocker, déplacer ou expédier des cartes de circuits imprimés.

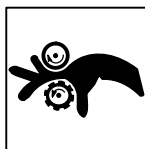

DES ORGANES MOBILES peuvent provoquer des blessures.

- Ne pas s'approcher des organes mobiles.
- Ne pas s'approcher des points de coincement tels que des rouleaux de commande.



LES FILS DE SOUDAGE peuvent provoquer des blessures.

- Ne pas appuyer sur la gachette avant d'en avoir reçu l'instruction.
- Ne pas diriger le pistolet vers soi, d'autres personnes ou toute pièce mécanique en engageant le fil de soudage.



DES ORGANES MOBILES peuvent provoquer des blessures.

- Rester à l'écart des organes mobiles comme le ventilateur.
- Maintenir fermés et fixement en place les portes, panneaux, recouvrements et dispositifs de protection.

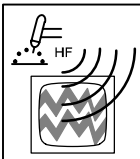

LE RAYONNEMENT HAUTE FRÉQUENCE (H.F.) risque de provoquer des interférences.

- Le rayonnement haute fréquence peut provoquer des interférences avec les équipements de radio-navigation et de communication, les services de sécurité et les ordinateurs.
- Demander seulement à des personnes qualifiées familiarisées avec des équipements électroniques de faire fonctionner l'installation.
- L'utilisateur est tenu de faire corriger rapidement par un électricien qualifié les interférences résultant de l'installation.
- Si le FCC signale des interférences, arrêter immédiatement l'appareil.
- Effectuer régulièrement le contrôle et l'entretien de l'installation.
- Maintenir soigneusement fermés les portes et les panneaux des sources de haute fréquence, maintenir les éclateurs à une distance correcte et utiliser une terre et un blindage pour réduire les interférences éventuelles.

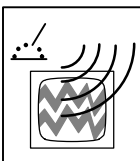

LE SOUDAGE À L'ARC risque de provoquer des interférences.

- L'énergie électromagnétique risque de provoquer des interférences pour l'équipement électronique sensible tel que les ordinateurs et l'équipement commandé par ordinateur tel que les robots.
- Veiller à ce que tout l'équipement de la zone de soudage soit compatible électromagnétiquement.
- Pour réduire la possibilité d'interférence, maintenir les câbles de soudage aussi courts que possible, les grouper, et les poser aussi bas que possible (ex. par terre).
- Veiller à souder à une distance de 100 mètres de tout équipement électronique sensible.
- Veiller à ce que ce poste de soudage soit posé et mis à la terre conformément à ce mode d'emploi.
- En cas d'interférences après avoir pris les mesures précédentes, il incombe à l'utilisateur de prendre des mesures supplémentaires telles que le déplacement du poste, l'utilisation de câbles blindés, l'utilisation de filtres de ligne ou la pose de protecteurs dans la zone de travail.

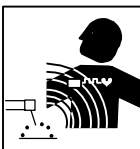

LES CHAMPS MAGNÉTIQUES peuvent affecter les stimulateurs cardiaques.

- Porteurs de stimulateur cardiaque, restez à distance.
- Les porteurs d'un stimulateur cardiaque doivent d'abord consulter leur médecin avant de s'approcher des opérations de soudage à l'arc, de gougeage ou de soudage par points.

1-4. Principales normes de sécurité

Safety in Welding and Cutting, norme ANSI Z49.1, de l'American Welding Society, 550 N.W. Lejeune Rd, Miami FL 33126

Safety and Health Standards, OSHA 29 CFR 1910, du Superintendent of Documents, U.S. Government Printing Office, Washington, D.C. 20402.

Recommended Safe Practice for the Preparation for Welding and Cutting of Containers That Have Held Hazardous Substances, norme AWS F4.1, de l'American Welding Society, 550 N.W. Lejeune Rd, Miami FL 33126

National Electrical Code, NFPA Standard 70, de la National Fire Protection Association, Batterymarch Park, Quincy, MA 02269.

Safe Handling of Compressed Gases in Cylinders, CGA Pamphlet P-1, de la Compressed Gas Association, 1235 Jefferson Davis Highway, Suite 501, Arlington, VA 22202.

Règles de sécurité en soudage, coupage et procédés connexes, norme CSA W117.2, de l'Association canadienne de normalisation, vente de normes, 178 Rexdale Boulevard, Rexdale (Ontario) Canada M9W 1R3.

Safe Practices For Occupation And Educational Eye And Face Protection, norme ANSI Z87.1, de l'American National Standards Institute, 1430 Broadway, New York, NY 10018.

Cutting and Welding Processes, norme NFPA 51B, de la National Fire Protection Association, Batterymarch Park, Quincy, MA 02269.

1-5. Information sur les champs électromagnétiques

Données sur le soudage électrique et sur les effets, pour l'organisme, des champs magnétiques basse fréquence

Le courant de soudage, pendant son passage dans les câbles de soudage, causera des champs électromagnétiques. Il y a eu et il y a encore un certain souci à propos de tels champs. Cependant, après avoir examiné plus de 500 études qui ont été faites pendant une période de recherche de 17 ans, un comité spécial ruban bleu du National Research Council a conclu: "L'accumulation de preuves, suivant le jugement du comité, n'a pas démontré que l'exposition aux champs magnétiques et champs électriques à haute fréquence représente un risque à la santé humaine". Toutefois, des études sont toujours en cours et les preuves continuent à être examinées. En attendant que les conclusions finales de la recherche soient établies, il vous serait souhaitable de réduire votre exposition aux champs électromagnétiques pendant le soudage ou le coupage.

Afin de réduire les champs électromagnétiques dans l'environnement de travail, respecter les consignes suivantes :

- 1 Garder les câbles ensemble en les torsadant ou en les attachant avec du ruban adhésif.
- 2 Mettre tous les câbles du côté opposé de l'opérateur.
- 3 Ne pas courber pas et ne pas entourer pas les câbles autour de votre corps.
- 4 Garder le poste de soudage et les câbles le plus loin possible de vous.
- 5 Relier la pince de masse le plus près possible de la zone de soudure.

Consignes relatives aux stimulateurs cardiaques :

Les personnes qui portent un stimulateur cardiaque doivent avant tout consulter leur docteur. Si vous êtes déclaré apte par votre docteur, il est alors recommandé de respecter les consignes ci-dessus.

SECTION 2 – INSTALLATION

2-1. Specifications

Welding Circuit Rating	Input Power Cord With Plug	Type Of Input Power		Dimensions			Weight	
		115 Volts	230 Volts	Height	Width	Length	115 Volts	230 Volts
250 Amperes At 60% Duty Cycle	10 ft (3 m)	115 Volts AC Single-Phase 50/60/100 Hz, 1.5 Amperes	230 Volts AC Single-Phase 50/60 Hz, 0.75 Amperes	15 in (381 mm)	9-1/4 in (235 mm)	16 in (406 mm)	Net: 34 lb (15 kg) Ship: 37 lb (17 kg)	Net: 36 lb (16 kg); Ship: 39 lb (18 kg)

2-2. Typical Process Connections

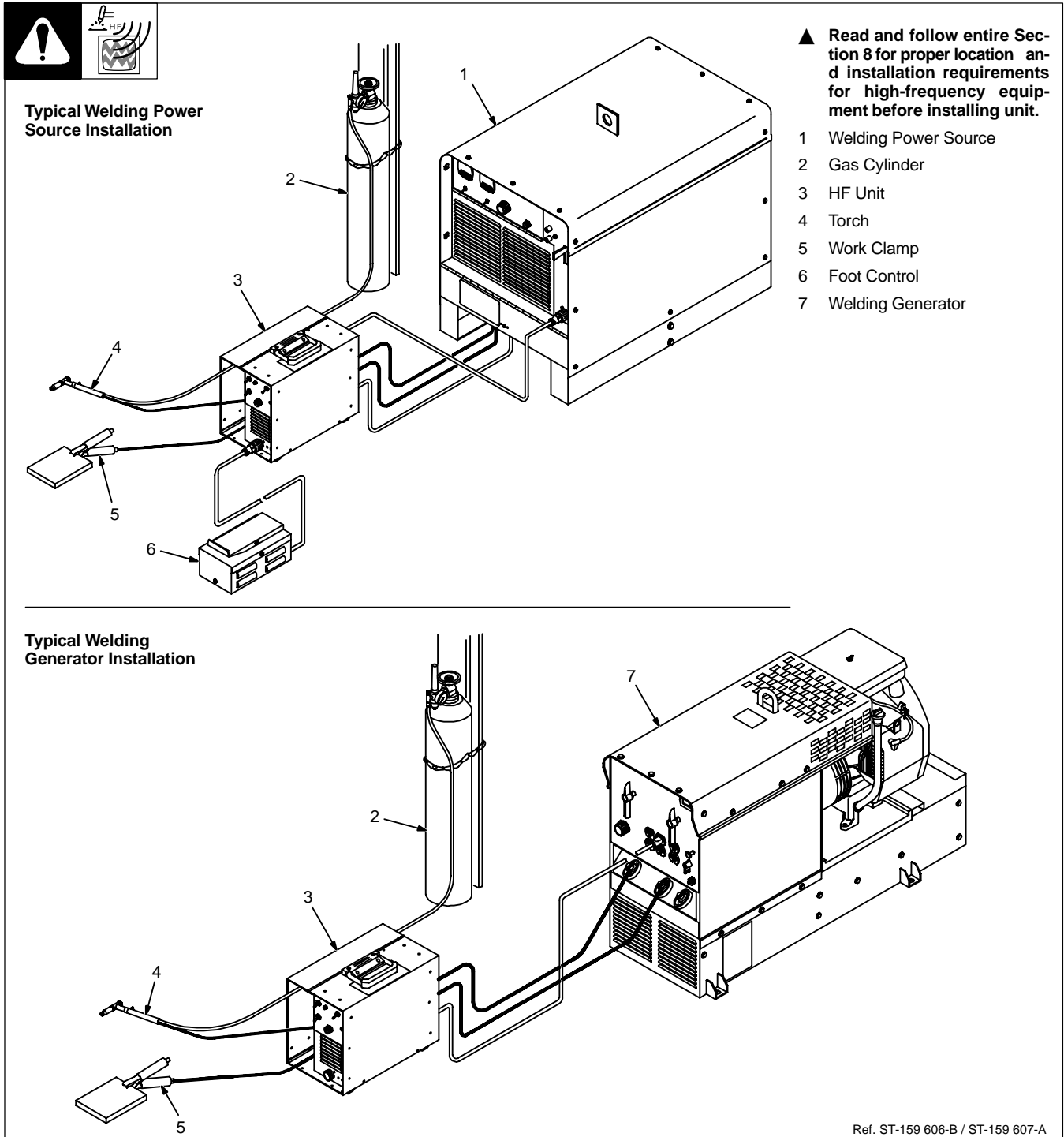

Ref. ST-159 606-B / ST-159 607-A

2-3. Installing Gas Supply

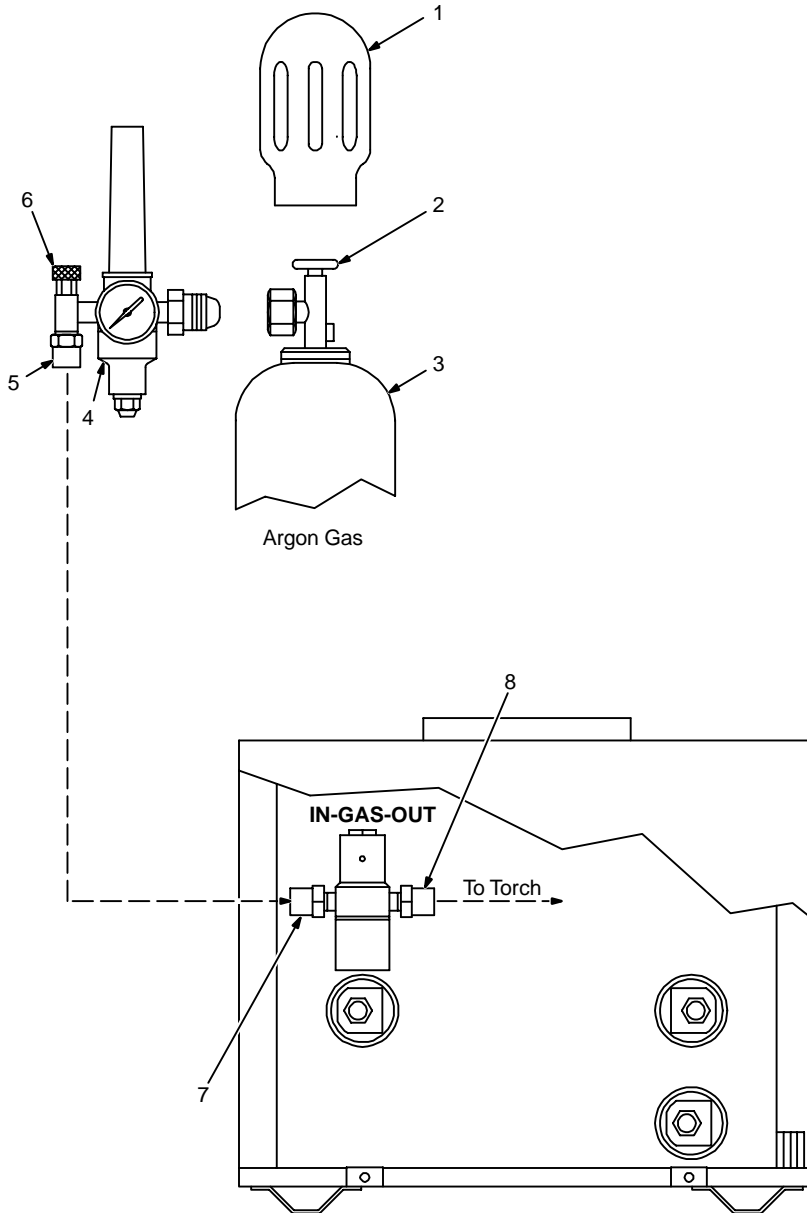

Obtain gas cylinder and chain to running gear, wall, or other stationary support so cylinder cannot fall and break off valve.

- 1 Cap
- 2 Cylinder Valve

Remove cap, stand to side of valve, and open valve slightly. Gas flow blows dust and dirt from valve. Close valve.

- 3 Cylinder
- 4 Regulator/Flowmeter

Install so face is vertical.

- 5 Gas Hose Connection

Fitting has 5/8-18 right-hand threads.

- 6 Flow Adjust

Typical flow rate is 15 cfh (cubic feet per hour).

Make sure flow adjust is closed when opening cylinder to avoid damage to the flowmeter.

- 7 Gas In Fitting

- 8 Gas Out Fitting

Open left side panel.

The Gas In and Gas Out fittings have 5/8-18 right-hand threads. Obtain proper size, type, and length hose and make connections as follows:

Connect hose from shielding gas supply regulator/flowmeter to Gas In fitting.

Connect shielding gas hose from torch to Gas Out fitting.

Close left side panel.

Tools Needed:

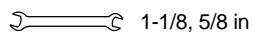

NOTE

The supplied cord with plugs is for use with CC or CC/CV welding power sources having the proper, matching 14-pin receptacle. Do not use cordset on machines without the 14-pin receptacle.

2-4. Power Source Plug Information And Connections



Connect Remote 14 Plug PLG4 if remote contactor and/or remote amperage control from the HF unit are desired.

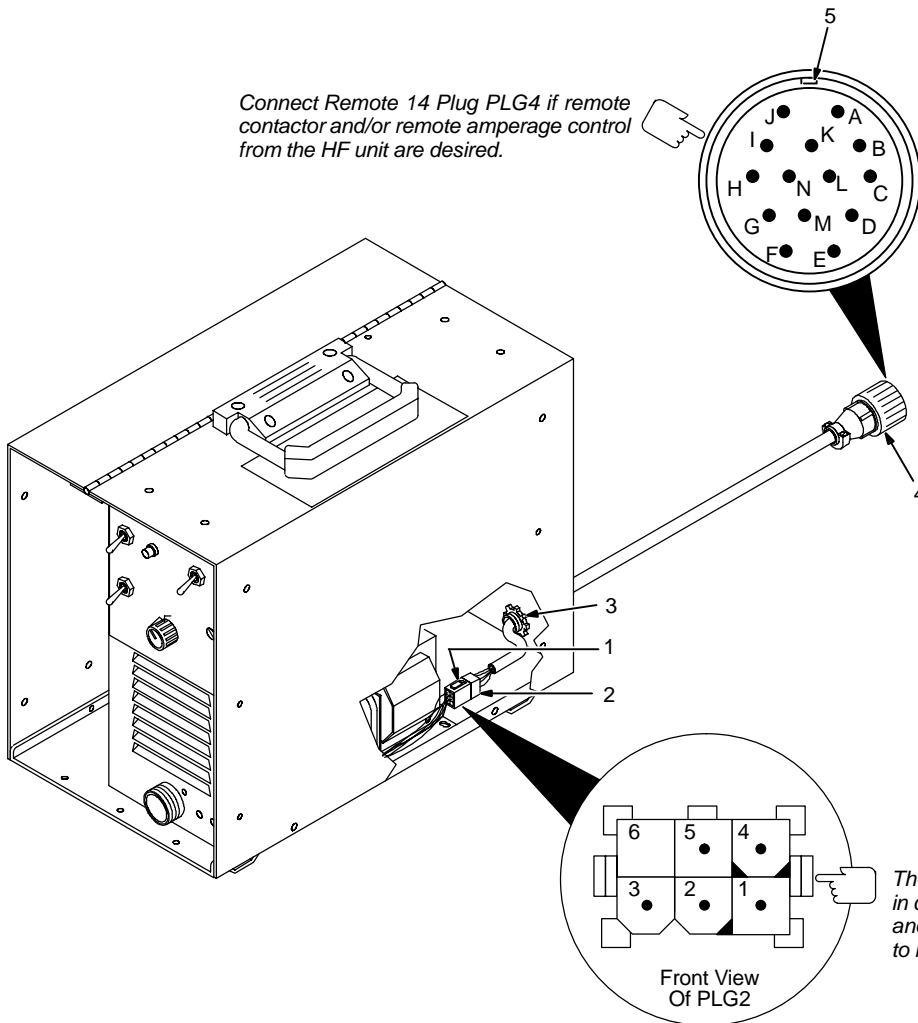

▲ Turn Off HF Unit and welding power source, and disconnect input power before making connections. Stop engine on welding generators.

- 1 Six-Pin Power Source Block Plug PLG2
- 2 Supplied Six-Pin Receptacle RC2
- 3 Strain Relief Clamp
- 4 Remote 14 Plug PLG4
- 5 Keyway

To Connect PLG4 to Remote 14 receptacle on the welding power source, align keyway, insert plug and tighten threaded collar.

The following pin information is included in case the supplied cord is not suitable, and it is necessary to wire a receptacle to interface with plug PLG2.

	Pin*	Pin Informaton
Remote Contactor Control	1, 2	Provides contact closure for Output (Contactor) operation.
Remote Amperage Control	3 4 5	Amperage control connection – maximum side. Amperage control connection – wiper contact. Amperage control connection – minimum side.

*The remaining pin is not used.

2-5. Operator Control Receptacle Information And Connections

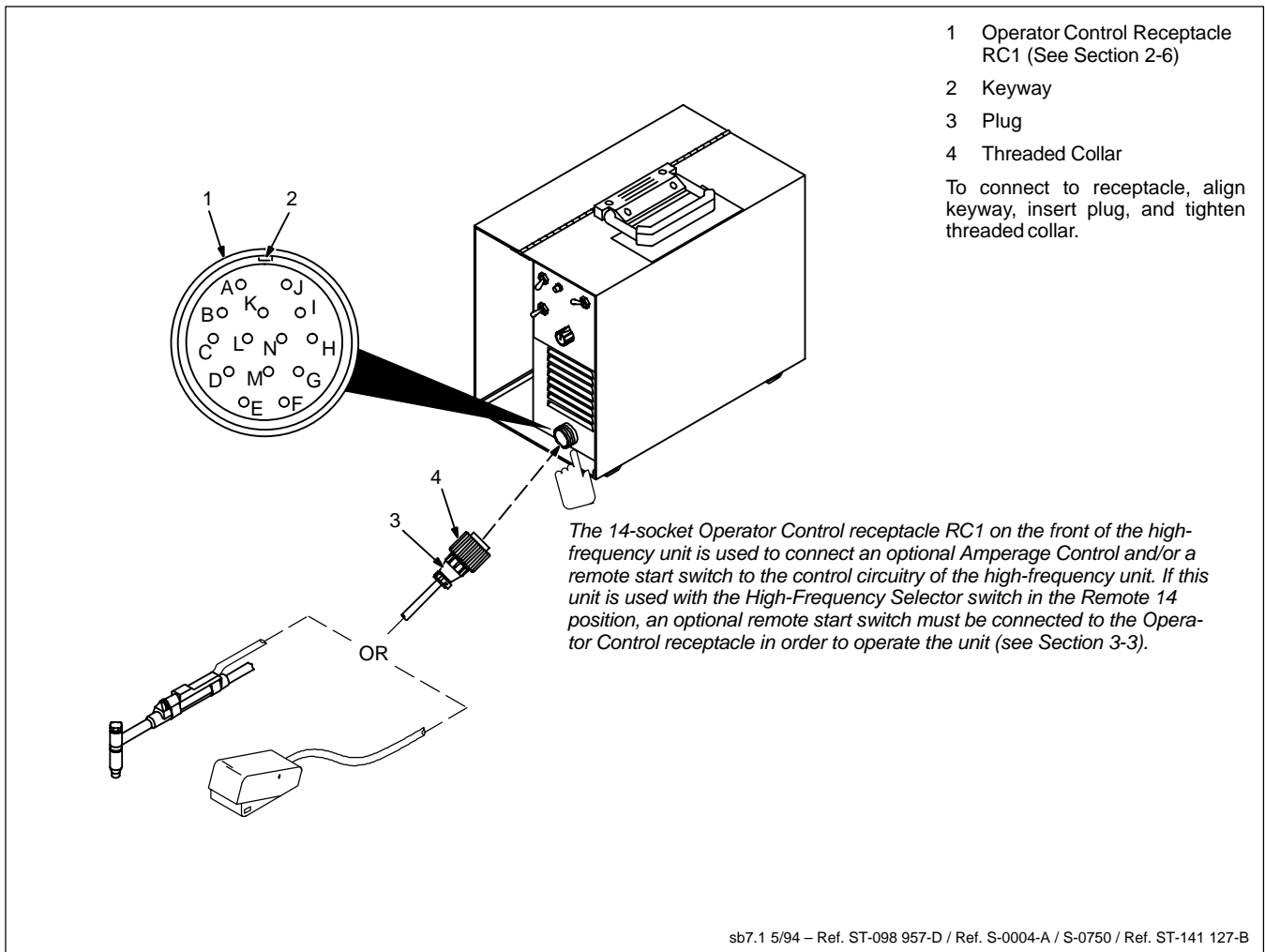

2-6. Operator Control Receptacle Socket Information

	Socket*	Socket Information
<p>OUTPUT (CONTACTOR) FEEDER</p>	A, B	Contact closure to A completes control circuit for High Frequency and Remote Start switch.
<p>A/V AMPERAGE VOLTAGE</p>	C D E	+10 volts dc output to remote control. Remote control circuit common. 0 to +10 volts dc input command signal from remote control.

*The remaining sockets are not used.

2-7. Connecting To Weld Output Terminals

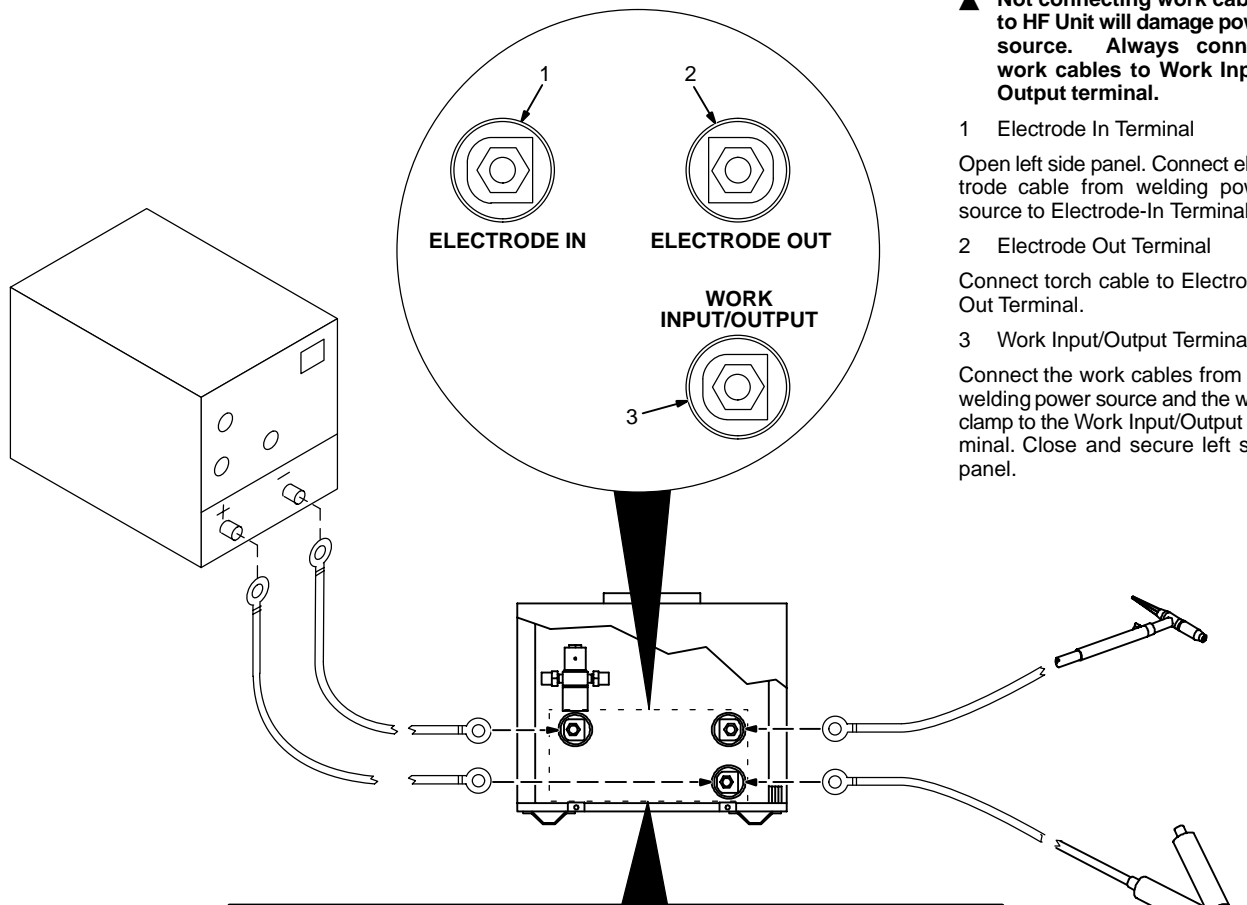

▲ Turn Off HF Unit and welding power source, and disconnect input power before making connections. Stop engine on welding generators.

▲ Not connecting work cables to HF Unit will damage power source. Always connect work cables to Work Input/Output terminal.

1 Electrode In Terminal

Open left side panel. Connect electrode cable from welding power source to Electrode-In Terminal.

2 Electrode Out Terminal

Connect torch cable to Electrode-Out Terminal.

3 Work Input/Output Terminal

Connect the work cables from the welding power source and the work clamp to the Work Input/Output terminal. Close and secure left side panel.

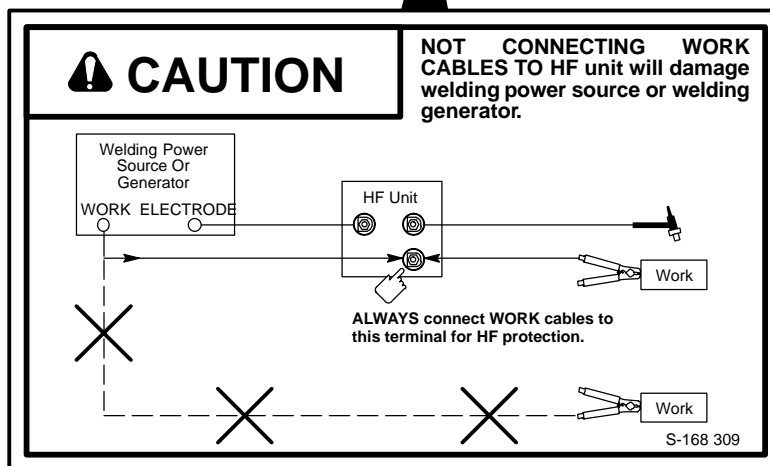

Tools Needed:

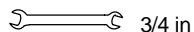

2-8. Connecting Input Power



▲ Read and follow entire Section 8 about HF equipment before installing unit.

▲ Direct Current (DC) will damage HF Unit. Connect unit only to Alternating Current (AC) supply. Do not cut grounding terminal off plug.

1 Grounded Receptacle

See Section 2-1 for type of input power required.

2 Plug From Unit

Insert plug into receptacle.

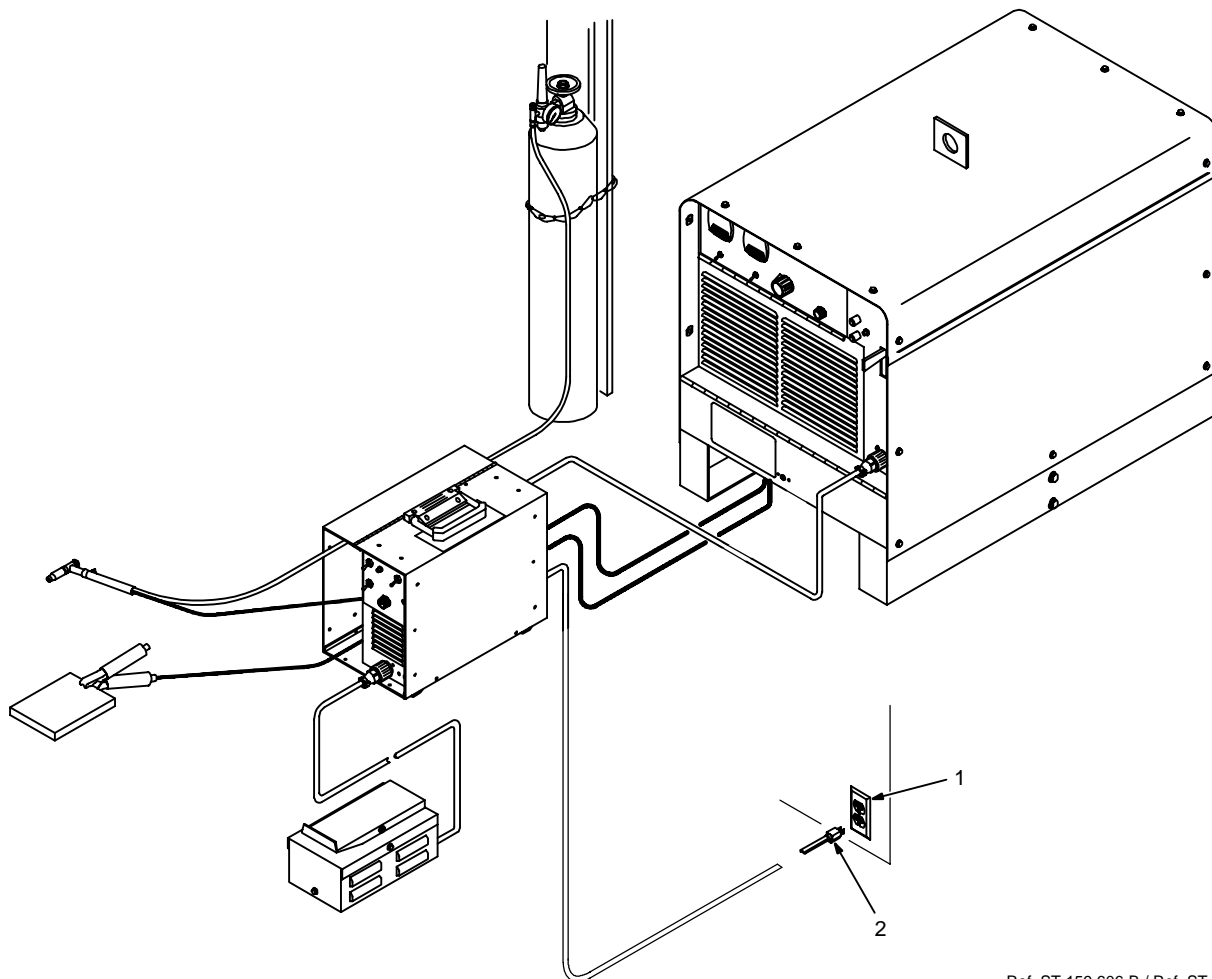

Ref. ST-159 606-B / Ref. ST-149 354-A

SECTION 3 – OPERATION

3-1. Controls

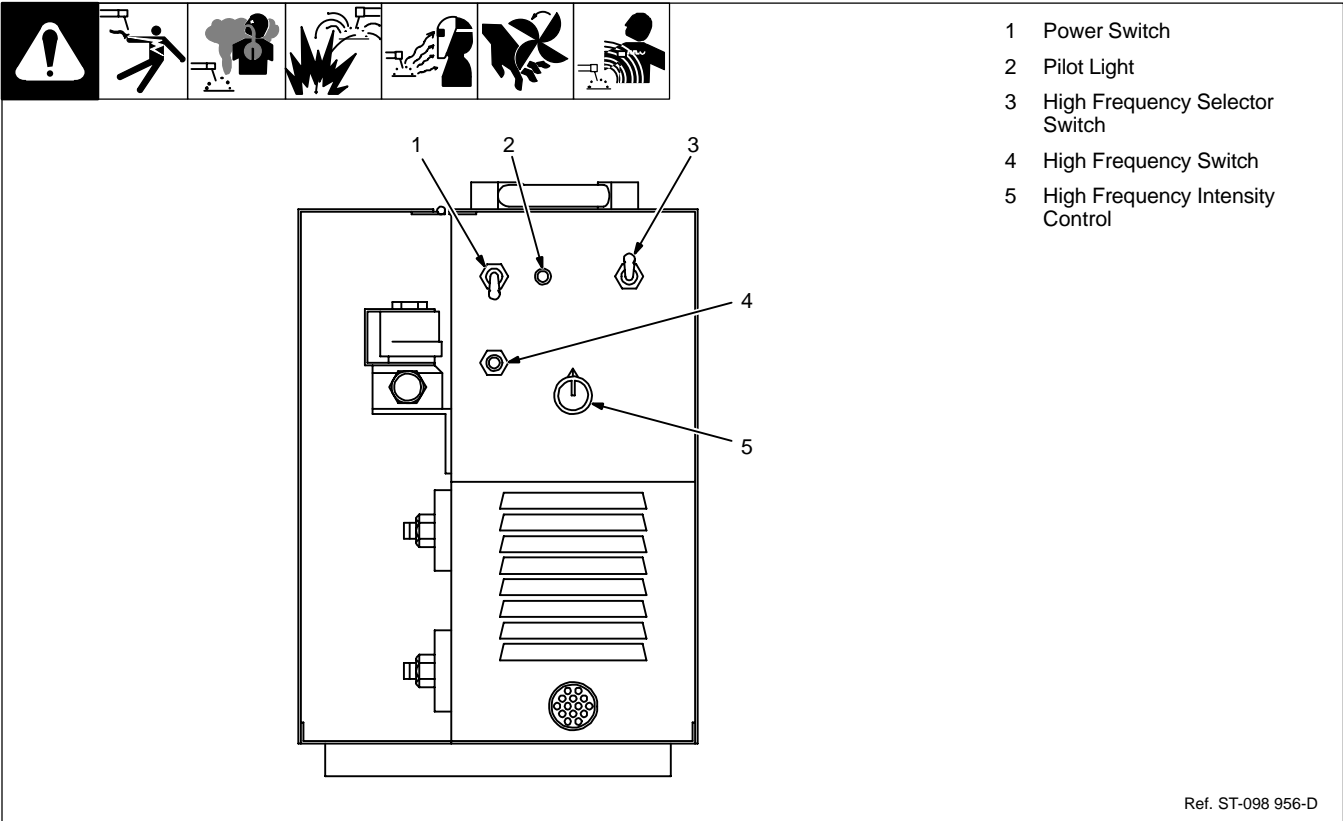

- 1 Power Switch
- 2 Pilot Light
- 3 High Frequency Selector Switch
- 4 High Frequency Switch
- 5 High Frequency Intensity Control

Ref. ST-098 956-D

3-2. High Frequency Switch

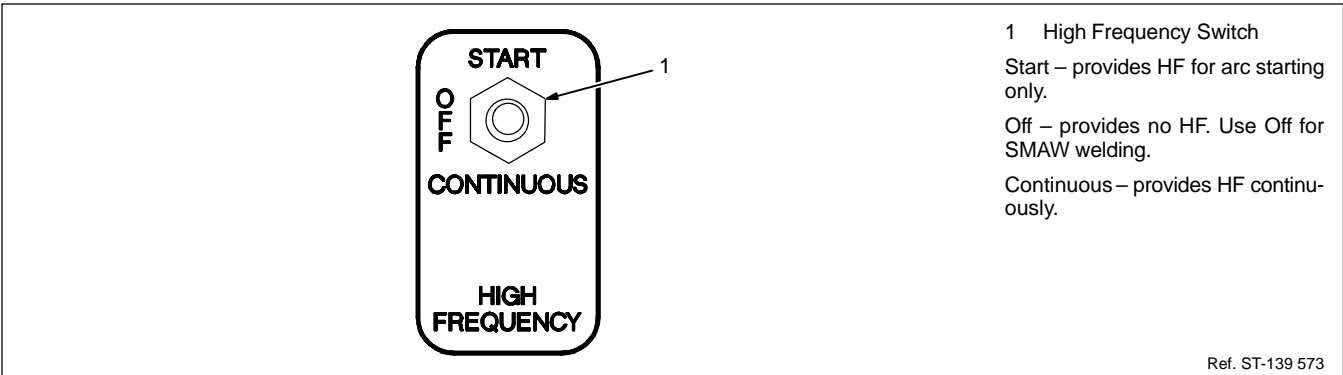

- 1 High Frequency Switch
- Start – provides HF for arc starting only.
- Off – provides no HF. Use Off for SMAW welding.
- Continuous – provides HF continuously.

Ref. ST-139 573

3-3. High Frequency Selector Switch

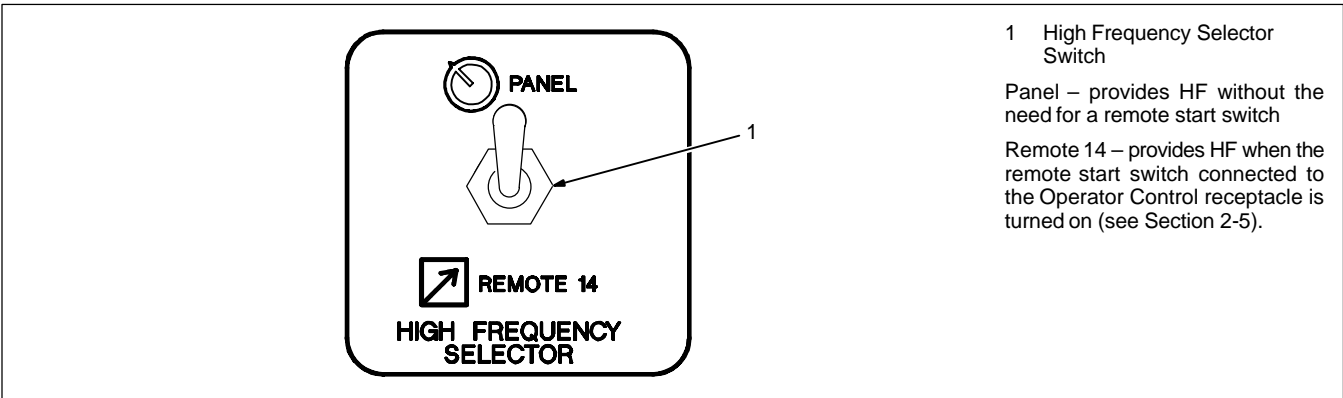

- 1 High Frequency Selector Switch
- Panel – provides HF without the need for a remote start switch
- Remote 14 – provides HF when the remote start switch connected to the Operator Control receptacle is turned on (see Section 2-5).

3-4. High Frequency Intensity Control

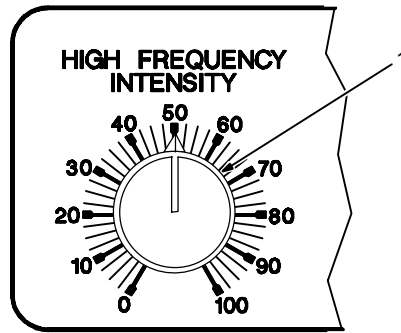

1 High Frequency Intensity Control

Use control to change amount of HF energy used to start and/or maintain the arc. Set as low as practical to prevent interfering with electronic equipment.

3-5. Power Switch And Pilot Light

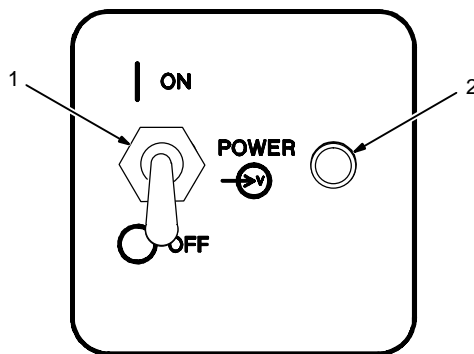

1 Power Switch

Use switch to turn unit On and Off.

2 Pilot Light

3-6. Postflow Timer

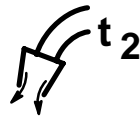

Postflow Timer

A fixed 15 second Postflow Timer controls the period of time shielding gas flows after the arc is extinguished.

3-7. Shielding Gas

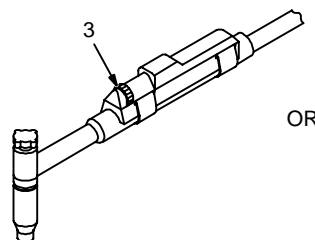
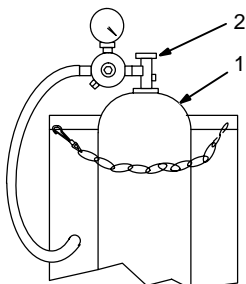

OR

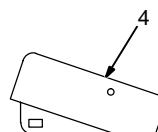

1 Shielding Gas Cylinder

2 Valve

3 Hand Control

4 Foot Control

Open valve on cylinder just before welding.

Control turns weld output and gas flow on and off.

Close valve on cylinder when finished welding.

SECTION 4 – MAINTENANCE & TROUBLESHOOTING

4-1. Routine Maintenance



 **Disconnect all power before maintaining.**

 **3 Months**

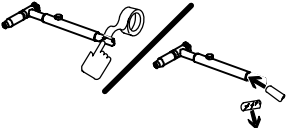

Tape Or
Replace
Cracked
Cables



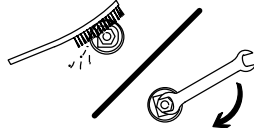

Replace
Unreadable
Labels

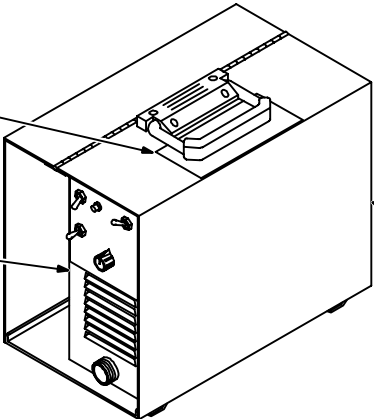

Clean And
Tighten
Weld
Terminals



 **3 Months**



Replace
Cracked
Parts



14-Pin Cord



Gas Hose

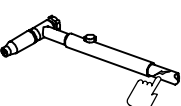

Torch Cable

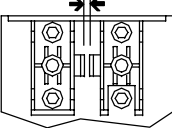

Adjust
Spark
Gaps

 **6 Months**

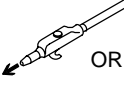

OR



Blow Out
Or
Vacuum
Inside

During Heavy Service,
Clean Monthly

ST-155 457

4-2. Adjusting Spark Gaps



Rear Of Unit

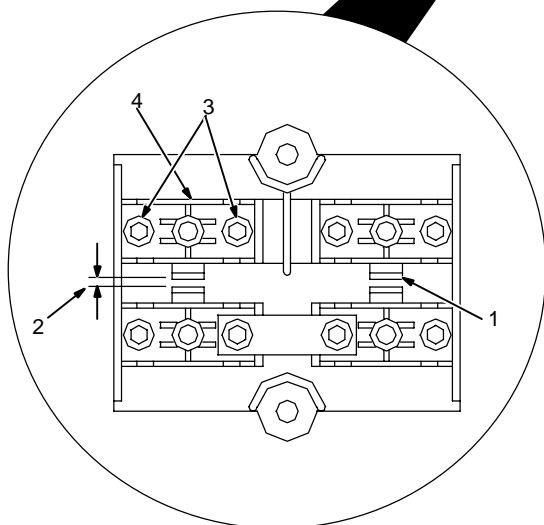
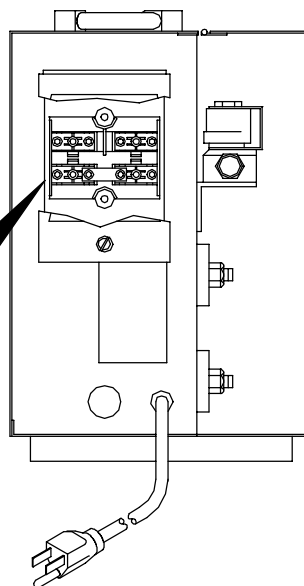

Turn Off unit and welding power source and disconnect input power.

Loosen screw on spark gap access door and open.

1 Tungsten End Of Point

Do not clean or dress tungsten. Replace point if tungsten end disappears.

2 Spark Gap

Normal spark gap is 0.008 in (0.203 mm).

If spark gaps are okay, reinstall door. If adjustment is needed, continue as follows:

3 Adjustment Screws

Loosen screws. Place gauge of proper thickness in spark gap.

4 Pressure Point

Apply slight pressure at point until gauge is held firmly in gap. Tighten adjustment screws to 12 in/lbs torque (overtightening will deform plastic base). Repeat gauge adjustment with other gap.

Close access door.

Tools Needed:

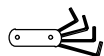

5/32 in

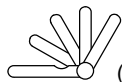

0.008 in
(0.203 mm)

Ref. ST-098 956-F

4-3. Troubleshooting



Trouble	Remedy
Unit completely inoperative; Pilot light Off.	Secure input power cord plug in receptacle (see Section 2-8).
	Place Power switch in the On position (see Section 3-5).
Lack of high-frequency; difficulty in establishing an arc.	Place High Frequency Selector Switch in the correct position (see Section 3-3).
	Be sure torch cable is not close to any grounded metal.
	Check cables and torch for cracked insulation or bad connections. Repair or replace necessary parts.
	Increase setting of High Frequency Intensity Control (see Section 3-4).
	Select proper size tungsten (see Section 7-1).
	Check spark gaps and adjust if necessary (see Section 4-2).
Wandering arc – poor control of direction of arc.	Reduce gas flow rate (see Section 2-3).
	Select proper size tungsten (see Section 7-1).
	Properly prepare tungsten (see Section 7-2 or 7-3).
	Increase setting of High Frequency Intensity Control (see Section 3-4).
Tungsten electrode oxidizing and not remaining bright after conclusion of weld.	Shield weld zone of drafts.
	Check and tighten all gas fittings (see Section 2-3).
	Properly prepare tungsten (see Section 7-2 or 7-3).
	Replace torch parts if water has leaked into torch.

SECTION 5 – ELECTRICAL DIAGRAMS

SB-130 555-A

WARNING
ELECTRIC SHOCK HAZARD

- Do not touch live electrical parts.
- Disconnect input power or stop engine before servicing.
- Do not operate with covers removed.
- Have only qualified persons install, use, or service this unit.

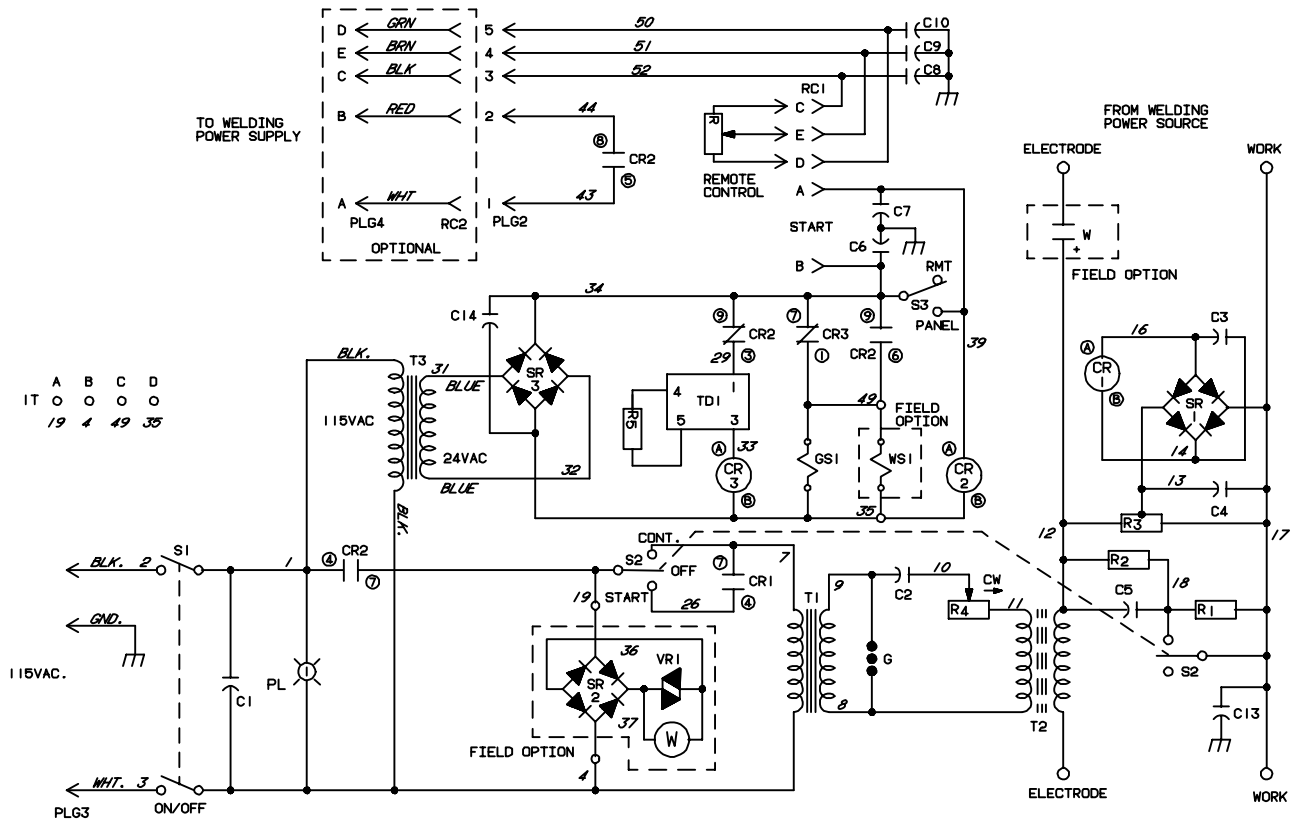

Figure 5-1. Circuit Diagram For 115 Volts Model

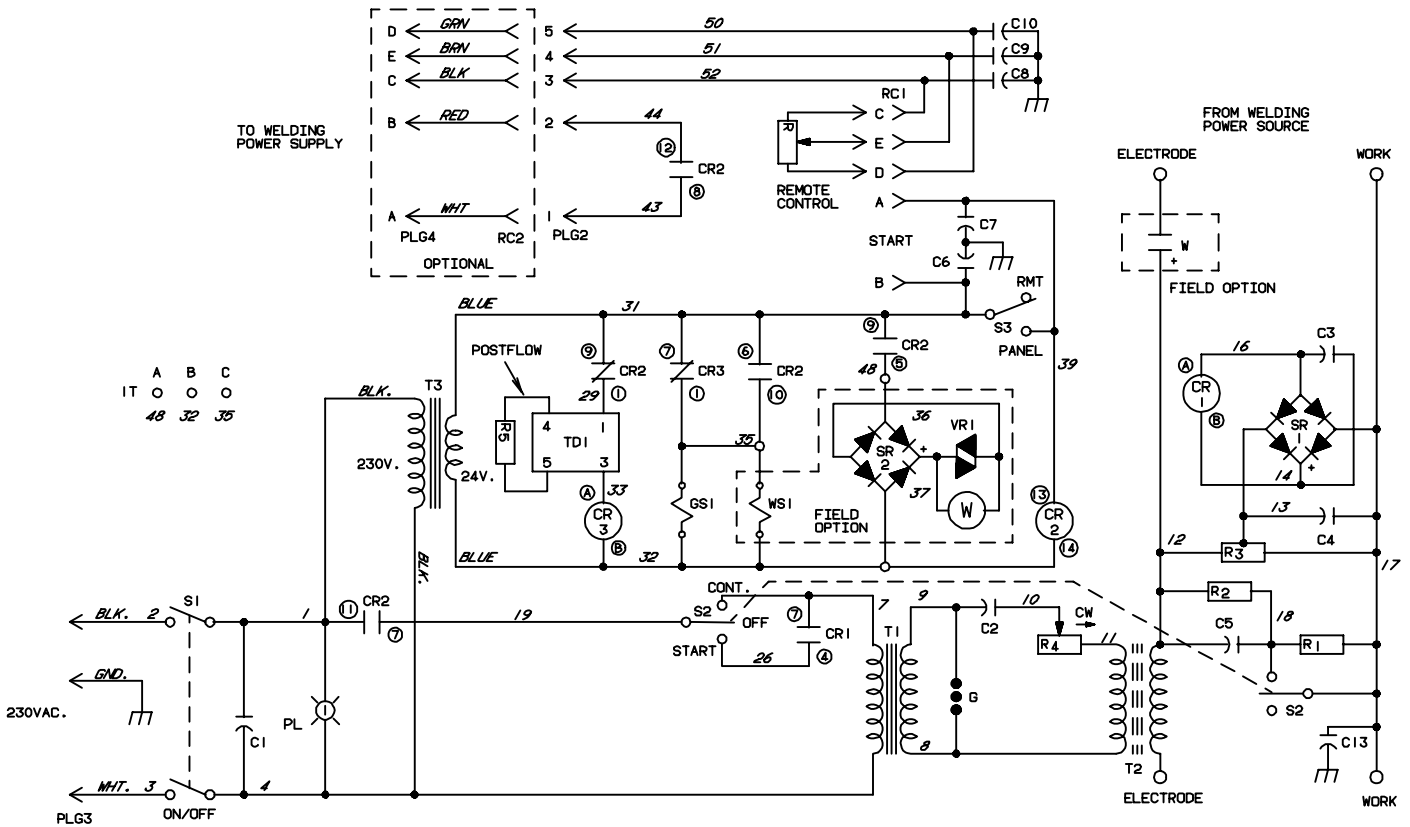
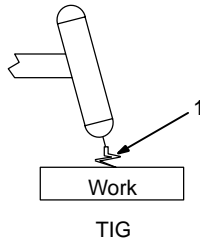

Figure 5-2. Circuit Diagram For 230 Volts Model

SB-140 903-A

SECTION 6 – HIGH FREQUENCY

6-1. Welding Processes Requiring High Frequency



1 High-Frequency Voltage

TIG – helps arc jump air gap between torch and workpiece and/or stabilize the arc.

high_freq 12/96 – S-0693

6-2. Incorrect Installation

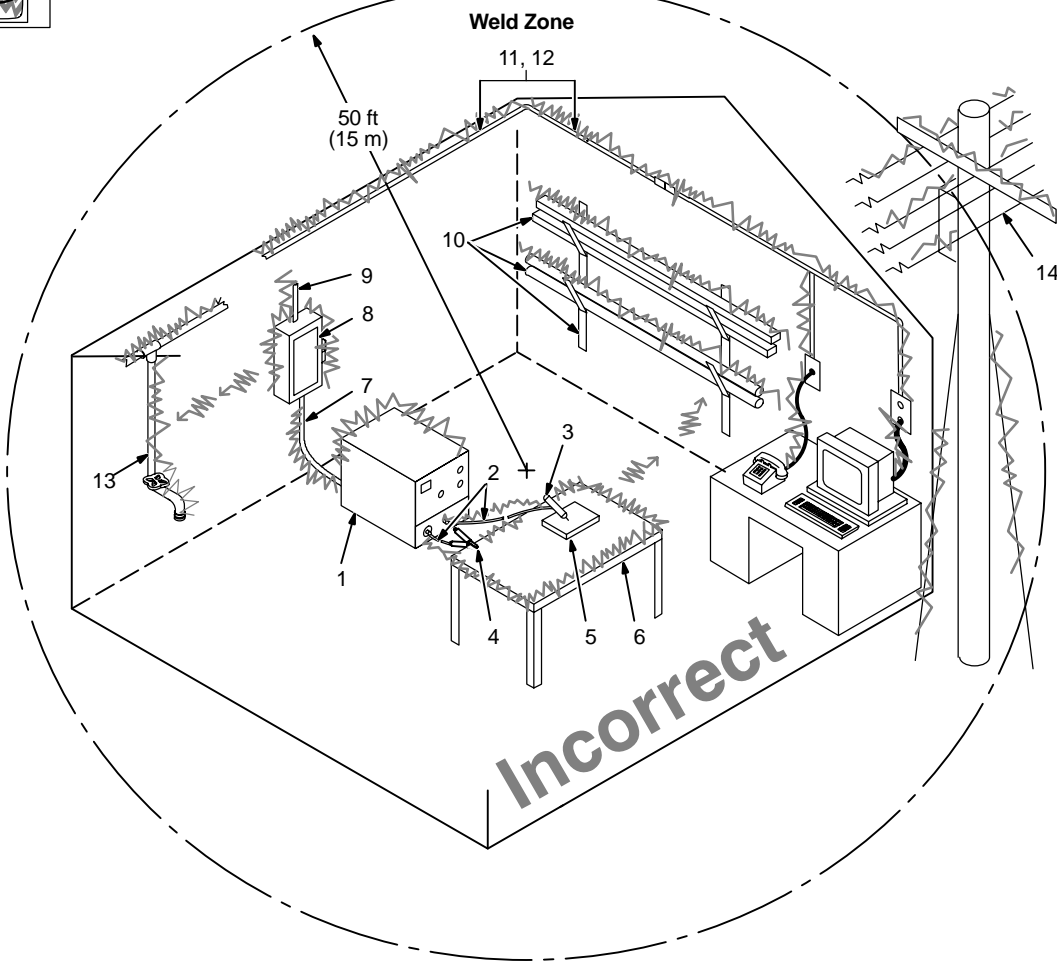

Sources of Direct High-Frequency Radiation

- 1 High-Frequency Source (welding power source with built-in HF or separate HF unit)
- 2 Weld Cables
- 3 Torch
- 4 Work Clamp
- 5 Workpiece
- 6 Work Table

Sources of Conduction of High Frequency

- 7 Input Power Cable
- 8 Line Disconnect Device
- 9 Input Supply Wiring

Sources of Reradiation of High Frequency

- 10 Ungrounded Metal Objects
- 11 Lighting
- 12 Wiring
- 13 Water Pipes and Fixtures
- 14 External Phone and Power Lines

S-0694

6-3. Correct Installation

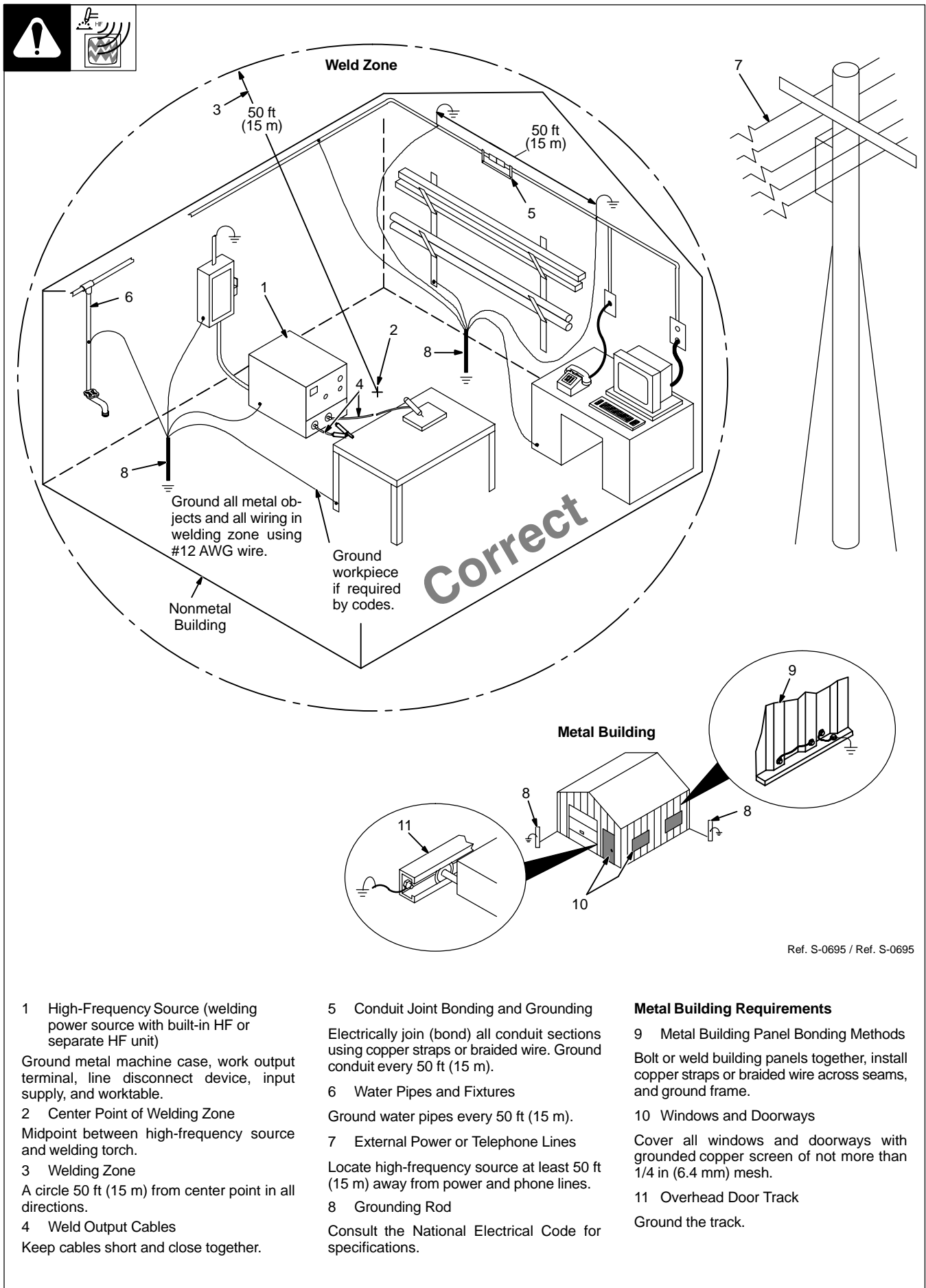

- 1 High-Frequency Source (welding power source with built-in HF or separate HF unit)

Ground metal machine case, work output terminal, line disconnect device, input supply, and worktable.

- 2 Center Point of Welding Zone

Midpoint between high-frequency source and welding torch.

- 3 Welding Zone

A circle 50 ft (15 m) from center point in all directions.

- 4 Weld Output Cables

Keep cables short and close together.

- 5 Conduit Joint Bonding and Grounding

Electrically join (bond) all conduit sections using copper straps or braided wire. Ground conduit every 50 ft (15 m).

- 6 Water Pipes and Fixtures

Ground water pipes every 50 ft (15 m).

- 7 External Power or Telephone Lines

Locate high-frequency source at least 50 ft (15 m) away from power and phone lines.

- 8 Grounding Rod

Consult the National Electrical Code for specifications.

Metal Building Requirements

- 9 Metal Building Panel Bonding Methods

Bolt or weld building panels together, install copper straps or braided wire across seams, and ground frame.

- 10 Windows and Doorways

Cover all windows and doorways with grounded copper screen of not more than 1/4 in (6.4 mm) mesh.

- 11 Overhead Door Track

Ground the track.

SECTION 7 – SELECTING AND PREPARING TUNGSTEN ELECTRODE

gtaw 7/97

NOTE

For additional information, see your distributor for a handbook on the Gas Tungsten Arc Welding (GTAW) process. Wear clean gloves to prevent contamination of tungsten electrode.

7-1. Selecting Tungsten Electrode

Electrode Diameter	Amperage Range - Gas Type♦ - Polarity			
	DC – Argon – Electrode Negative/Straight Polarity	DC – Argon – Electrode Positive/Reverse Polarity	AC – Argon – Using High Frequency	AC – Argon – Balanced Wave Using High Freq.
Pure Tungsten (Green Band)				
.010"	Up to 15	*	Up to 15	Up to 10
.020"	5-20	*	5-20	10-20
.040"	15-80	*	10-60	20-30
1/16"	70-150	10-20	50-100	30-80
3/32"	125-225	15-30	100-160	60-130
1/8"	225-360	25-40	150-210	100-180
5/32"	360-450	40-55	200-275	160-240
3/16"	450-720	55-80	250-350	190-300
1/4"	720-950	80-125	325-450	250-400
2% Thorium Alloyed Tungsten (Red Band)				
.010"	Up to 25	*	Up to 20	Up to 15
.020"	15-40	*	15-35	5-20
.040"	25-85	*	20-80	20-60
1/16"	50-160	10-20	50-150	60-120
3/32"	135-235	15-30	130-250	100-180
1/8"	250-400	25-40	225-360	160-250
5/32"	400-500	40-55	300-450	200-320
3/16"	500-750	55-80	400-500	290-390
1/4"	750-1000	80-125	600-800	340-525
Zirconium Alloyed Tungsten (Brown Band)				
.010"	*	*	Up to 20	Up to 15
.020"	*	*	15-35	5-20
.040"	*	*	20-80	20-60
1/16"	*	*	50-150	60-120
3/32"	*	*	130-250	100-180
1/8"	*	*	225-360	160-250
5/32"	*	*	300-450	200-320
3/16"	*	*	400-550	290-390
1/4"	*	*	600-800	340-525

♦ Typical argon shielding gas flow rates are 15 to 35 cfh (cubic feet per hour).

*Not Recommended.

The figures listed are intended as a guide and are a composite of recommendations from American Welding Society (AWS) and electrode manufacturers.

7-2. Preparing Tungsten For AC Or DC Electrode Positive (DCEP) Welding

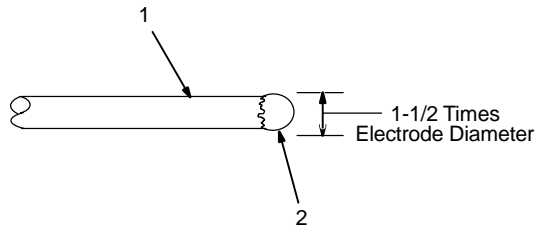

- 1 Tungsten Electrode
- 2 Balled End

▲ **Understand and follow safety symbols at start of Section 8-1 before preparing tungsten.**

Ball end of tungsten before welding by applying either an ac amperage slightly higher than what is recommended for a given electrode diameter (see Section 7-1), or a dc electrode positive amperage.

Ref. S-0161

7-3. Preparing Tungsten For DC Electrode Negative (DCEN) Welding

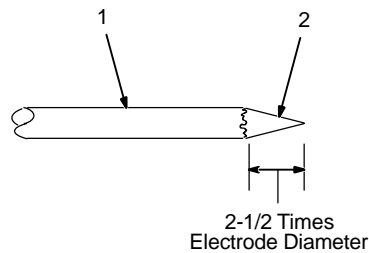

- 1 Tungsten Electrode
- 2 Tapered End

Grind end of tungsten on fine grit, hard abrasive wheel before welding. Do not use wheel for other jobs or tungsten can become contaminated causing lower weld quality.

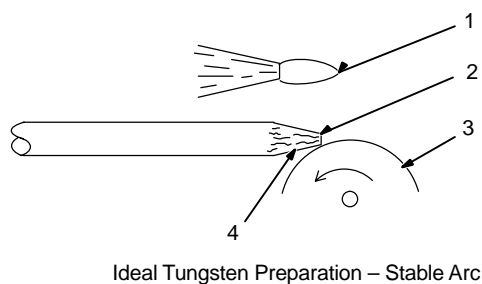

- 1 Stable Arc
- 2 Flat
- 3 Grinding Wheel
- 4 Straight Ground

Diameter of this flat determines amperage capacity.

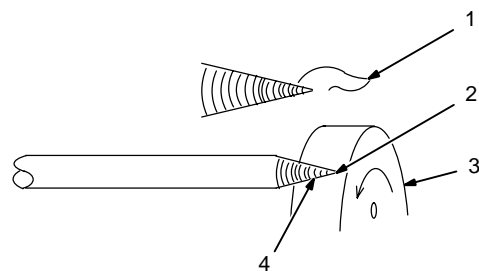

- 1 Arc Wander
- 2 Point
- 3 Grinding Wheel
- 4 Radial Ground

Wrong Tungsten Preparation – Wandering Arc

Ref. S-0161 / Ref. S-0162

SECTION 8 – GUIDELINES FOR TIG WELDING (GTAW)

8-1. Positioning The Torch



▲ Weld current can damage electronic parts in vehicles. Disconnect both battery cables before welding on a vehicle. Place work clamp as close to the weld as possible.

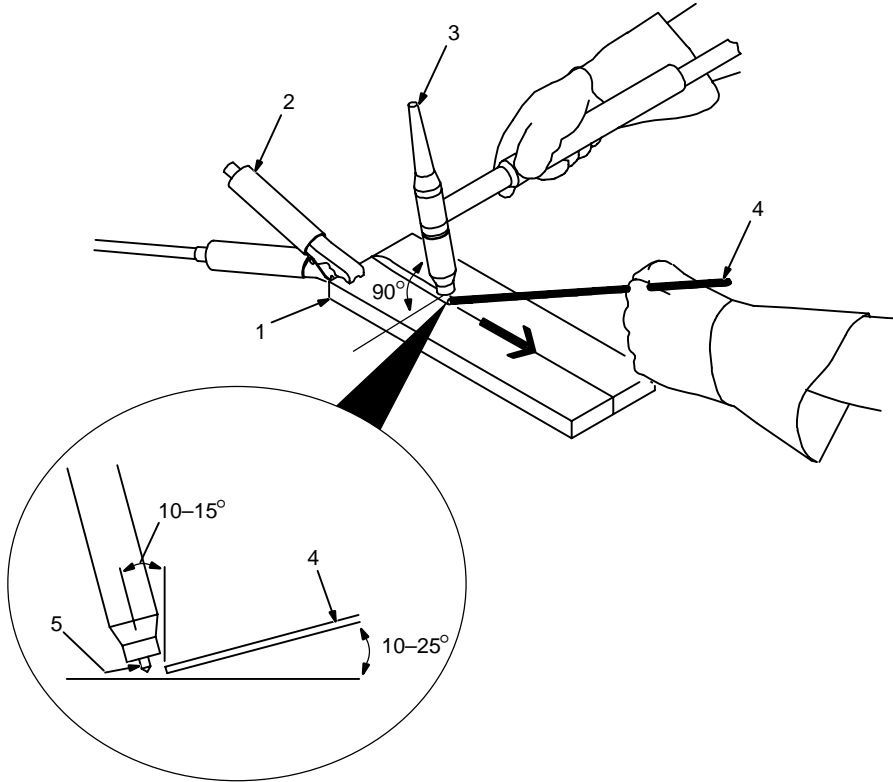

- 1 Workpiece
Make sure workpiece is clean before welding.
- 2 Work Clamp
Place as close to the weld as possible.
- 3 Torch
- 4 Filler Rod (If Applicable)
- 5 Tungsten Electrode
Select and prepare tungsten according to Sections 7-1, and 7-2 or 7-3.
Tungsten extension is the distance the tungsten extends out gas cup of torch.
Arc length is the distance from the tungsten to the workpiece.
As a general guide, start with an extension and arc length equal to diameter of tungsten.

ST-161 892

8-2. Torch Movement During Welding

Tungsten Without Filler Rod

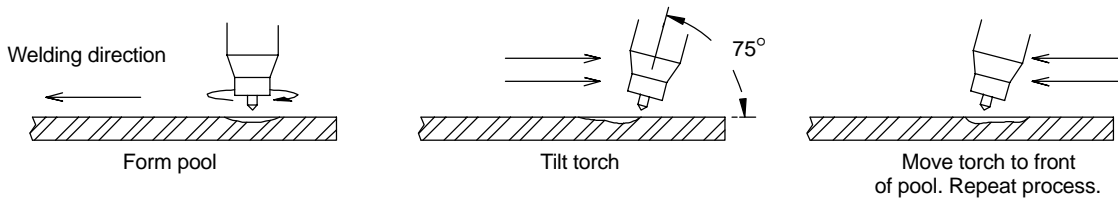

Tungsten With Filler Rod

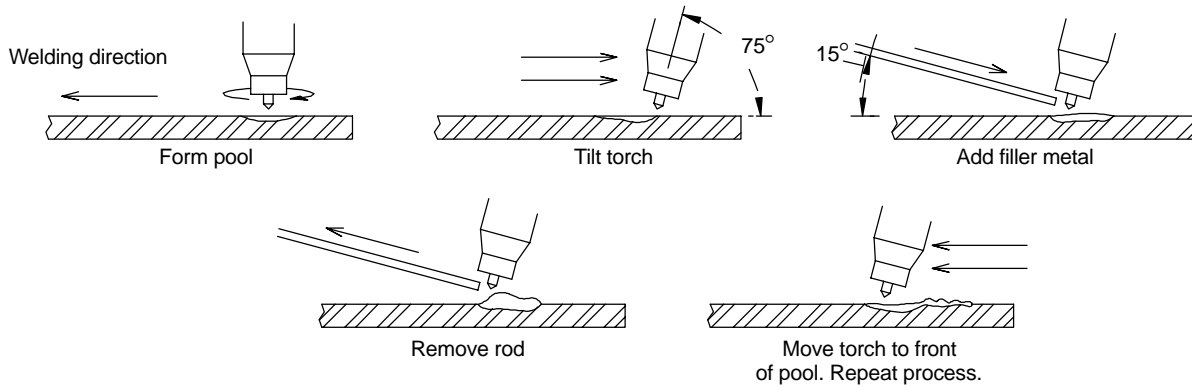

ST-162 002-B

8-3. Positioning Torch Tungsten For Various Weld Joints

Butt Weld And Stringer Bead

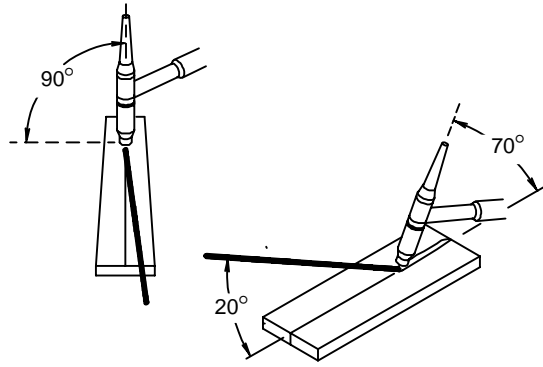

"T" Joint

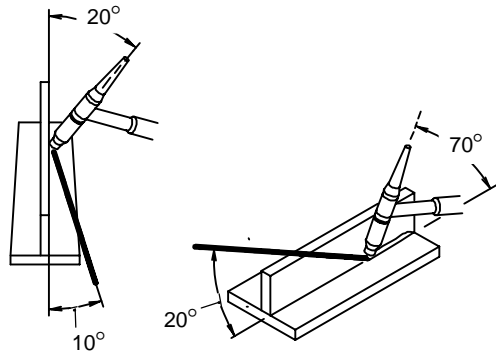
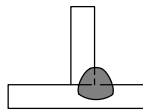

Lap Joint

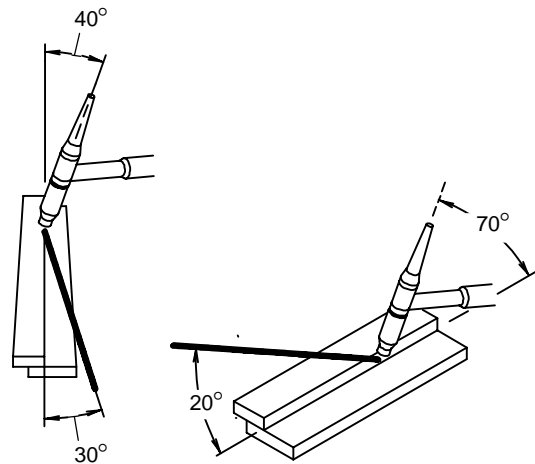
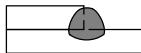

Corner Joint

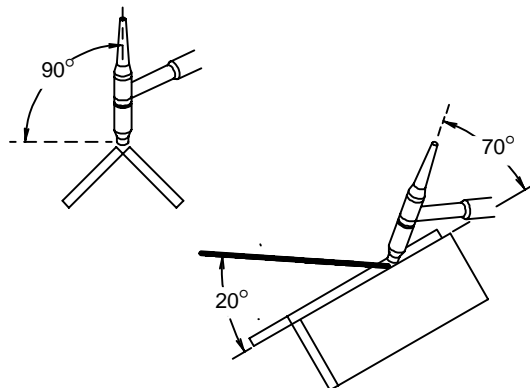
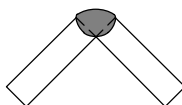

SECTION 9 – PARTS LIST

 Hardware is common and not available unless listed.

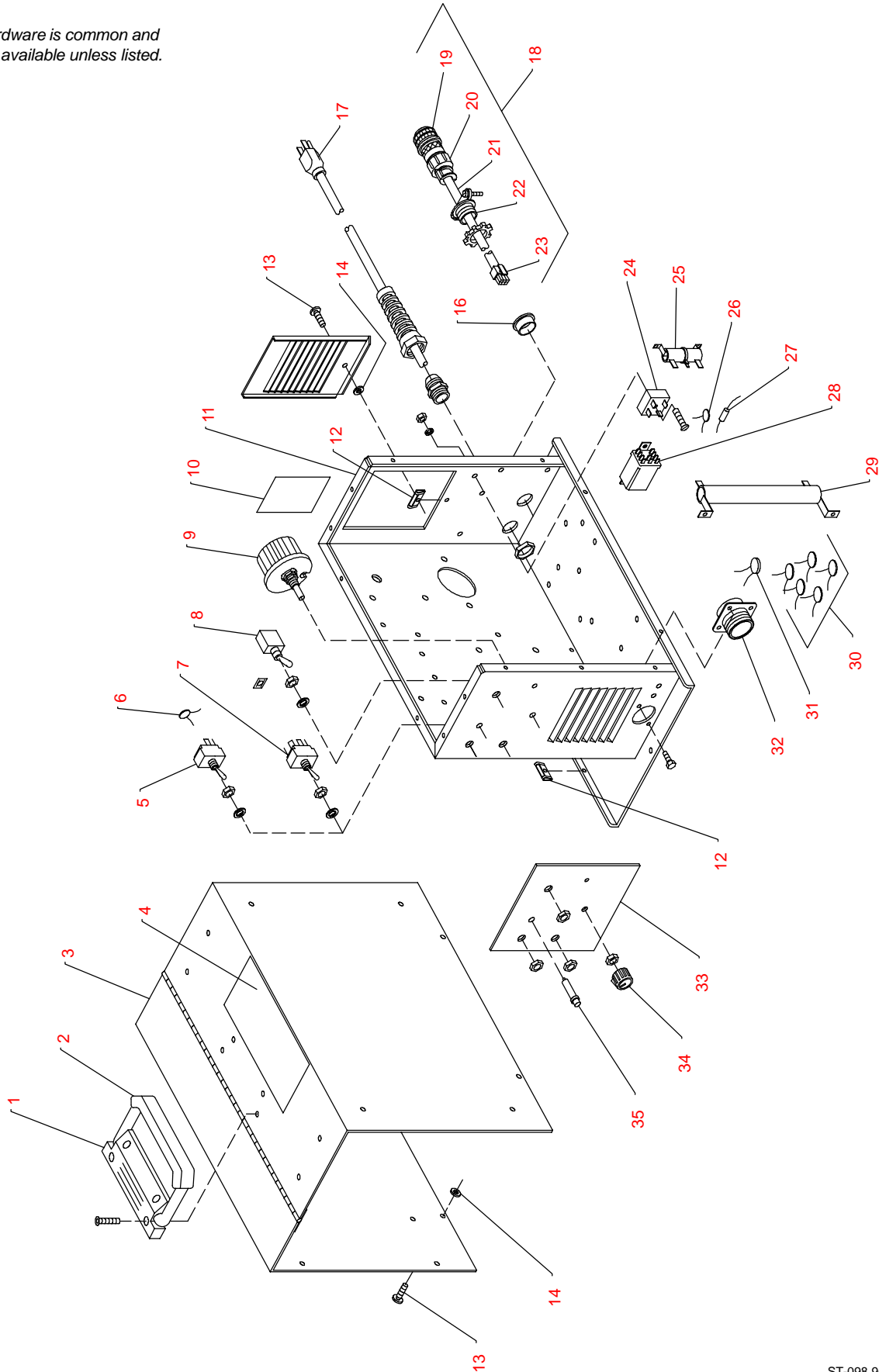

Figure 9-1. Complete Assembly (Part 1 of 2) (115V Model)

Item No.	Dia. Mkgs.	Part No.	Description	Quantity	
				115V	230V

Figure 9-1. Complete Assembly (Part 1 of 2)

...	1	126 415	.. CLAMP, saddle	1	1
...	2	126 416	.. HANDLE, chest	1	1
...	3	+129 366	.. WRAPPER	1	1
...	4	121 316	.. LABEL, warning general precautionary	1	1
...	5	S1 028 111	.. SWITCH, tgl DPST 20A 250V	1	1
...	6	C1 106 601	.. CAPACITOR, cer disc .01 uf 500V	1	1
...	7	S2 088 409	.. SWITCH, tgl DPDT 15A 125VAC	1	1
...	8	S3 089 085	.. SWITCH, tgl SPST 20A 125VAC	1	1
...	9	R4 198 547	.. RHEOSTAT, WW 25W 1.5 ohm	1	1
...	10	128 230	.. LABEL, warning electric shock	1	1
...	11	+131 097	.. CASE	1	1
...		168 309	.. LABEL, caution (located on LH side of case bottom)	1	1
...	12	010 357	.. NUT, speed No. 2 clip on	3	3
...	13	078 034	.. FASTENER, screw sltd hd .736 lg	1	1
...	14	010 855	.. RETAINER, screw No. 2	3	3
...	16	000 527	.. BLANK, snap-in nyl .875mtg hole	1	1
...	17	PLG3 136 080	.. CABLE, pwr 10ft 16ga 3/c	1	
...	17	PLG3 023 625	.. CORD SET, 250V 16 ga 3/c 10ft		1
...	18	130 336	.. CABLE, interconnecting (consisting of)	1	1
...	19	PLG4 144 310	.. CONNECTOR PLUG & PINS, (consisting of)	1	1
...	20	143 992	.. CONNECTOR, circ clamp str rlf	1	1
...		134 731	.. CONNECTOR, circ pin push-in 18-14ga	2	2
...	21	175 284	.. CABLE, pwr No. 20ga 5/c (order by ft)	6ft	6ft
...	22	115 104	.. CONNECTOR, clamp cable .500	1	1
...	23	RC2 115 093	.. CONNECTOR PLUG & SOCKETS	1	1
...	24	SR1 035 704	.. RECTIFIER, integ 40A 800V	1	1
...	25	R3 030 601	.. RESISTOR, WW adj 25W 1K ohm	1	1
...	26	C4 112 161	.. CAPACITOR	1	1
...	27	C3 031 630	.. CAPACITOR, elctlt 22uf 50VDC	1	1
...	28	CR1 059 267	.. RELAY, encl 12VDC DPDT w/flange	1	1
...	29	R1 083 784	.. RESISTOR, WW fxd 100W 10 ohm	1	1
...	30	C6 143 919	.. LEAD ASSEMBLY, elect	1	
...	30	C6 143 921	.. LEAD ASSEMBLY, elect		1
...	30	C7 143 918	.. LEAD ASSEMBLY, elect	1	1
...	30	C8 143 917	.. LEAD ASSEMBLY, elect	1	1
...	30	C9 143 920	.. LEAD ASSEMBLY, elect	1	1
...	30	C10 143 916	.. LEAD ASSEMBLY, elect	1	1
...	31	C13 148 240	.. CAPACITOR	1	1
...	32	RC1 143 976	.. CONNECTOR w/TERMINALS	1	1
...	33		.. NAMEPLATE, (order by model and serial number)	1	1
...	34	097 922	.. KNOB, pointer	1	1
...	35	PL1 027 645	.. LIGHT, ind red lens 125VAC	1	
...	35	PL1 099 001	.. LIGHT, ind red lens 250VAC		1
...	36	010 853	.. FASTENER, screw sltd hd No. 2	2	2

+When ordering a component originally displaying a precautionary label, the label should also be ordered.

To maintain the factory original performance of your equipment, use only Manufacturer's Suggested Replacement Parts. Model and serial number required when ordering parts from your local distributor.

 Hardware is common and not available unless listed.

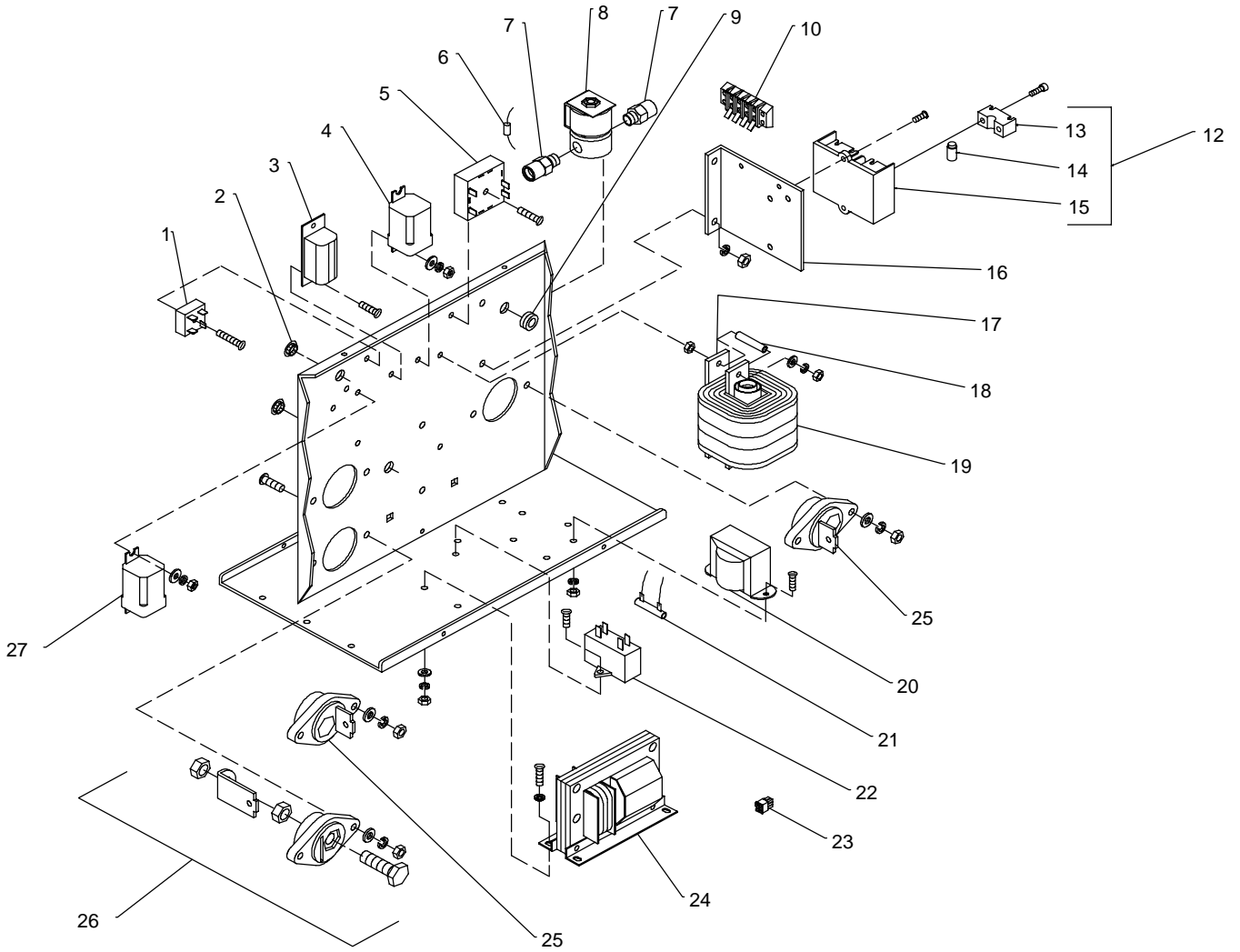

ST-098 955-L Part 2 of 2

Figure 9-2. Complete Assembly (Part 2 of 2) (115V Model)

Item No.	Dia. Mkgs.	Part No.	Description	Quantity	
				115V	230V

Figure 9-2. Complete Assembly (Part 2 of 2)

...	1	SR3	035 704	RECTIFIER, integ 40A 800V	1	
...		C14	031 630	CAPACITOR, elctlt 22uf 50VDC	1	
...	2		107 983	BLANK, snap-in nyl .500mtg hole	2	2
...	3	C2	191 868	CAPACITOR, mica .002uf 10000V	1	1
...	4	CR3	052 964	RELAY, encl 24VDC DPDT	1	
...	4	CR3	006 393	RELAY, encl 24VAC DPDT		1
...	5	TD1	114 494	TIMER, delay	1	1
...	6	R5	072 561	RESISTOR, MF .25W 267K ohm	1	1
...	7		010 604	FITTING, hose brs bushing 1/4 NPT x .625 -18RH	2	2
...	8	GS1	109 293	VALVE, 24VDC 2 way 1/4 IPS port 1/8 orf	1	
...	8	GS1	035 630	VALVE, 24VAC/6VDC 2 way 1/4 IPS port 1/8 orf		1
...	9		088 731	BUSHING, snap-in nyl .375 ID x .500mtg hole	2	2
...	10	1T	038 081	BLOCK, term 20A 4P	1	
...	10	1T	038 861	BLOCK, term 20A 3P		1
...			035 131	CONNECTOR, block 30A	4	3
...	12		199 854	SPARK GAP, (consisting of)	1	1
...	13	G	*196 455	HOLDER, point	4	4
...	14		199 856	POINT	4	4
...	15		199 855	BASE	1	1
...	16		097 612	BRACKET, mtg spark gap	1	1
...	17		133 845	STRIP, mtg HF coil	1	1
...	18		059 873	TUBING, stl .375 OD x .256 ID	2	2
...	19	T2	186 357	COIL, HF coupling	1	1
...	20	T3	036 135	TRANSFORMER, control 115-24VAC	1	
...	20	T3	099 002	TRANSFORMER, control 75VA 230V		1
...	21	R2	030 603	RESISTOR, WW fxd 10W 10K ohm	1	1
...	22	C5	191 944	CAPACITOR, polyp film 10uf 250VAC	1	1
...	23	PLG2	131 059	CONNECTOR PLUG & SOCKETS	1	1
...	24	T1	074 398	TRANSFORMER, high voltage 115V pri 3600V sec 30mA	1	
...	24	T1	098 966	TRANSFORMER, high voltage 230V pri 3600V sec		1
...	25	ELEC	099 255	TERMINAL, power output neutral	2	2
...	26	WORK	039 047	TERMINAL, power output red	1	1
...	27	CR2	116 592	RELAY, encl 24VDC 3PDT	1	
...	27	CR2	140 772	RELAY, encl 24VAC 4PDT		1

*Recommended Spare Parts.

To maintain the factory original performance of your equipment, use only Manufacturer's Suggested Replacement Parts. Model and serial number required when ordering parts from your local distributor.

TRUE BLUE[®]

WARRANTY

Effective January 1, 2000

(Equipment with a serial number preface of "LA" or newer)

This limited warranty supersedes all previous Miller warranties and is exclusive with no other guarantees or warranties expressed or implied.

Warranty Questions?

Call
1-800-4-A-MILLER
for your local
Miller distributor.

Your distributor also gives you ...

Service

You always get the fast, reliable response you need. Most replacement parts can be in your hands in 24 hours.

Support

Need fast answers to the tough welding questions? Contact your distributor. The expertise of the distributor and Miller is there to help you, every step of the way.

LIMITED WARRANTY – Subject to the terms and conditions below, Miller Electric Mfg. Co., Appleton, Wisconsin, warrants to its original retail purchaser that new Miller equipment sold after the effective date of this limited warranty is free of defects in material and workmanship at the time it is shipped by Miller. THIS WARRANTY IS EXPRESSLY IN LIEU OF ALL OTHER WARRANTIES, EXPRESS OR IMPLIED, INCLUDING THE WARRANTIES OF MERCHANTABILITY AND FITNESS.

Within the warranty periods listed below, Miller will repair or replace any warranted parts or components that fail due to such defects in material or workmanship. Miller must be notified in writing within thirty (30) days of such defect or failure, at which time Miller will provide instructions on the warranty claim procedures to be followed.

Miller shall honor warranty claims on warranted equipment listed below in the event of such a failure within the warranty time periods. All warranty time periods start on the date that the equipment was delivered to the original retail purchaser, or one year after the equipment is sent to a North American distributor or eighteen months after the equipment is sent to an International distributor.

1. 5 Years Parts – 3 Years Labor
 - * Original main power rectifiers
 - * Inverters (input and output rectifiers only)
2. 3 Years — Parts and Labor
 - * Transformer/Rectifier Power Sources
 - * Plasma Arc Cutting Power Sources
 - * Semi-Automatic and Automatic Wire Feeders
 - * Inverter Power Supplies
 - * Intelligig
 - * Engine Driven Welding Generators
(NOTE: Engines are warranted separately by the engine manufacturer.)
3. 1 Year — Parts and Labor
 - * DS-2 Wire Feeder
 - * Motor Driven Guns (w/exception of Spoolmate 185 & Spoolmate 250)
 - * Process Controllers
 - * Positioners and Controllers
 - * Automatic Motion Devices
 - * RFCS Foot Controls
 - * Induction Heating Power Sources
 - * Water Coolant Systems
 - * HF Units
 - * Grids
 - * Maxstar 140
 - * Spot Welders
 - * Load Banks
 - * Miller Cyclomatic Equipment
 - * Running Gear/Trailers
 - * Plasma Cutting Torches (except APT & SAF Models)
 - * Field Options
(NOTE: Field options are covered under True Blue[®] for the remaining warranty period of the product they are installed in, or for a minimum of one year — whichever is greater.)
4. 6 Months — Batteries
5. 90 Days — Parts
 - * MIG Guns/TIG Torches
 - * Induction Heating Coils and Blankets

- * APT, ZIPCUT & PLAZCUT Model Plasma Cutting Torches
- * Remote Controls
- * Accessory Kits
- * Replacement Parts (No labor)
- * Spoolmate 185 & Spoolmate 250
- * Canvas Covers

Miller's True Blue[®] Limited Warranty shall not apply to:

1. **Consumable components; such as contact tips, cutting nozzles, contactors, brushes, slip rings, relays or parts that fail due to normal wear.**
2. Items furnished by Miller, but manufactured by others, such as engines or trade accessories. These items are covered by the manufacturer's warranty, if any.
3. Equipment that has been modified by any party other than Miller, or equipment that has been improperly installed, improperly operated or misused based upon industry standards, or equipment which has not had reasonable and necessary maintenance, or equipment which has been used for operation outside of the specifications for the equipment.

MILLER PRODUCTS ARE INTENDED FOR PURCHASE AND USE BY COMMERCIAL/INDUSTRIAL USERS AND PERSONS TRAINED AND EXPERIENCED IN THE USE AND MAINTENANCE OF WELDING EQUIPMENT.

In the event of a warranty claim covered by this warranty, the exclusive remedies shall be, at Miller's option: (1) repair; or (2) replacement; or, where authorized in writing by Miller in appropriate cases, (3) the reasonable cost of repair or replacement at an authorized Miller service station; or (4) payment of or credit for the purchase price (less reasonable depreciation based upon actual use) upon return of the goods at customer's risk and expense. Miller's option of repair or replacement will be F.O.B., Factory at Appleton, Wisconsin, or F.O.B. at a Miller authorized service facility as determined by Miller. Therefore no compensation or reimbursement for transportation costs of any kind will be allowed.

TO THE EXTENT PERMITTED BY LAW, THE REMEDIES PROVIDED HEREIN ARE THE SOLE AND EXCLUSIVE REMEDIES. IN NO EVENT SHALL MILLER BE LIABLE FOR DIRECT, INDIRECT, SPECIAL, INCIDENTAL OR CONSEQUENTIAL DAMAGES (INCLUDING LOSS OF PROFIT), WHETHER BASED ON CONTRACT, TORT OR ANY OTHER LEGAL THEORY.

ANY EXPRESS WARRANTY NOT PROVIDED HEREIN AND ANY IMPLIED WARRANTY, GUARANTY OR REPRESENTATION AS TO PERFORMANCE, AND ANY REMEDY FOR BREACH OF CONTRACT TORT OR ANY OTHER LEGAL THEORY WHICH, BUT FOR THIS PROVISION, MIGHT ARISE BY IMPLICATION, OPERATION OF LAW, CUSTOM OF TRADE OR COURSE OF DEALING, INCLUDING ANY IMPLIED WARRANTY OF MERCHANTABILITY OR FITNESS FOR PARTICULAR PURPOSE, WITH RESPECT TO ANY AND ALL EQUIPMENT FURNISHED BY MILLER IS EXCLUDED AND DISCLAIMED BY MILLER.

Some states in the U.S.A. do not allow limitations of how long an implied warranty lasts, or the exclusion of incidental, indirect, special or consequential damages, so the above limitation or exclusion may not apply to you. This warranty provides specific legal rights, and other rights may be available, but may vary from state to state.

In Canada, legislation in some provinces provides for certain additional warranties or remedies other than as stated herein, and to the extent that they may not be waived, the limitations and exclusions set out above may not apply. This Limited Warranty provides specific legal rights, and other rights may be available, but may vary from province to province.





Owner's Record

Please complete and retain with your personal records.

Model Name	Serial/Style Number
Purchase Date	(Date which equipment was delivered to original customer.)
Distributor	
Address	
City	
State	Zip



For Service

Call 1-800-4-A-Miller or see our website at www.MillerWelds.com to locate a DISTRIBUTOR or SERVICE AGENCY near you.

Always provide Model Name and Serial/Style Number.

Contact your Distributor for:

- Welding Supplies and Consumables
- Options and Accessories
- Personal Safety Equipment
- Service and Repair
- Replacement Parts
- Training (Schools, Videos, Books)
- Technical Manuals (Servicing Information and Parts)
- Circuit Diagrams
- Welding Process Handbooks

Contact the Delivering Carrier for:

File a claim for loss or damage during shipment.

For assistance in filing or settling claims, contact your distributor and/or equipment manufacturer's Transportation Department.

Miller Electric Mfg. Co.

An Illinois Tool Works Company
1635 West Spencer Street
Appleton, WI 54914 USA

International Headquarters—USA

USA Phone: 920-735-4505 Auto-Attended
USA & Canada FAX: 920-735-4134
International FAX: 920-735-4125

European Headquarters – United Kingdom

Phone: 44 (0) 1204-593493
FAX: 44 (0) 1204-598066

www.MillerWelds.com



Miller
The Power of Blue.