



OM-4419

211 392A

June 2004

Processes



Stick (SMAW) Welding



MIG (GMAW) Welding
Flux Cored (FCAW) Welding



Non-Critical TIG (GTAW)
Welding

Description



Engine Driven Welding Generator

Bobcat™ 250

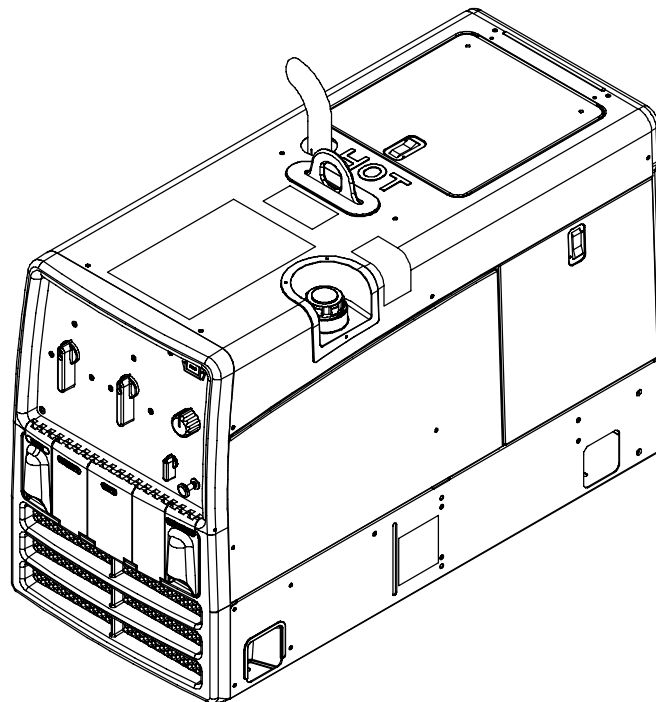

OWNER'S MANUAL



Visit our website at
www.MillerWelds.com

From Miller to You

Thank you and congratulations on choosing Miller. Now you can get the job done and get it done right. We know you don't have time to do it any other way.

That's why when Niels Miller first started building arc welders in 1929, he made sure his products offered long-lasting value and superior quality. Like you, his customers couldn't afford anything less. Miller products had to be more than the best they could be. They had to be the best you could buy.

Today, the people that build and sell Miller products continue the tradition. They're just as committed to providing equipment and service that meets the high standards of quality and value established in 1929.

This Owner's Manual is designed to help you get the most out of your Miller products. Please take time to read the Safety precautions. They will help you protect yourself against potential hazards on the worksite.

We've made installation and operation quick and easy. With Miller you can count on years of reliable service with proper maintenance. And if for some reason the unit needs repair, there's a Troubleshooting section that will help you figure out what the problem is. The parts list will then help you to decide the exact part you may need to fix the problem. Warranty and service information for your particular model are also provided.



Miller is the first welding equipment manufacturer in the U.S.A. to be registered to the ISO 9001:2000 Quality System Standard.

Miller Electric manufactures a full line of welders and welding related equipment. For information on other quality Miller products, contact your local Miller distributor to receive the latest full line catalog or individual catalog sheets. **To locate your nearest distributor or service agency call 1-800-4-A-Miller, or visit us at www.MillerWelds.com on the web.**



Working as hard as you do – every power source from Miller is backed by the most hassle-free warranty in the business.



TABLE OF CONTENTS

SECTION 1 – SAFETY PRECAUTIONS – READ BEFORE USING	1
1-1. Symbol Usage	1
1-2. Arc Welding Hazards	1
1-3. Engine Hazards	2
1-4. Compressed Air Hazards	3
1-5. Additional Symbols For Installation, Operation, And Maintenance	3
1-6. California Proposition 65 Warnings	4
1-7. Principal Safety Standards	4
1-8. EMF Information	4
SECTION 2 – CONSIGNES DE SÉCURITÉ – LIRE AVANT UTILISATION	5
2-1. Signification des symboles	5
2-2. Dangers relatifs au soudage à l'arc	5
2-3. Dangers existant en relation avec le moteur	6
2-4. Dangers liés à l'air comprimé	7
2-5. Dangers supplémentaires en relation avec l'installation, le fonctionnement et la maintenance	7
2-6. Principales normes de sécurité	8
2-7. Information sur les champs électromagnétiques	8
SECTION 3 – DEFINITIONS	9
SECTION 4 – SPECIFICATIONS	9
4-1. Weld, Power, and Engine Specifications	9
4-2. Dimensions, Weights, and Operating Angles	10
4-3. Generator Power Curve	10
4-4. Fuel Consumption (Robin-Powered Units)	11
4-5. Fuel Consumption (Kohler-Powered Units)	11
4-6. Volt-Ampere Curves	12
4-7. Duty Cycle	13
SECTION 5 – INSTALLATION	14
5-1. Installing Welding Generator	14
5-2. Engine Prestart Checks (Robin-Powered Units)	15
5-3. Engine Prestart Checks (Kohler-Powered Units)	16
5-4. Activating The Dry Charge Battery (If Applicable)	17
5-5. Connecting the Battery	18
5-6. Installing Exhaust Pipe	18
5-7. Connecting to Weld Output Terminals	19
5-8. Selecting Weld Cable Sizes*	19
SECTION 6 – OPERATING THE WELDING GENERATOR	20
6-1. Front Panel Controls	20
6-2. Typical Stick Welding Connections And Control Settings	21
6-3. Typical MIG Welding Connections And Settings	22
6-4. Typical MIG Connections And Settings Using Weld Control And Spoolgun	24
SECTION 7 – OPERATING AUXILIARY EQUIPMENT	25
7-1. Standard Receptacles	25
7-2. Optional Generator Power Receptacles	26
7-3. Wiring Optional 240 Volt Plug	27
SECTION 8 – MAINTENANCE (Robin-POWERED UNITS)	28
8-1. Routine Maintenance (Robin-Powered Units)	28
8-2. Maintenance Label (Robin-Powered Units)	29
8-3. Servicing Air Cleaner (Robin-Powered Units)	30
8-4. Overload Protection (Robin-Powered Units)	30
8-5. Changing Engine Oil, Oil Filter, and Fuel Filter (Robin-Powered Units)	31
8-6. Adjusting Engine Speed (Robin-Powered Units)	32
8-7. Servicing Optional Spark Arrestor (Robin-Powered Units)	33

TABLE OF CONTENTS

SECTION 9 – MAINTENANCE – (KOHLER-POWERED UNITS)	33
9-1. Maintenance Label (Kohler-Powered Units)	33
9-2. Routine Maintenance (Kohler-Powered Units)	34
9-3. Servicing Air Cleaner (Kohler-Powered Units)	35
9-4. Changing Engine Oil, Oil Filter, and Fuel Filter (Kohler-Powered Units)	36
9-5. Adjusting Engine Speed (Kohler-Powered Units)	37
9-6. Overload Protection (Kohler-Powered Units)	38
9-7. Servicing Optional Spark Arrestor (Kohler-Powered Units)	38
SECTION 10 – TROUBLESHOOTING	39
SECTION 11 – ELECTRICAL DIAGRAMS	42
SECTION 12 – GENERATOR POWER GUIDELINES	44
SECTION 13 – STICK WELDING (SMAW) GUIDELINES	51
SECTION 14 – MIG WELDING (GMAW) GUIDELINES	59
14-1. Typical MIG Process Connections Using A Voltage-Sensing Wire Feeder	59
14-2. Typical MIG Process Connections Using A Constant Speed Wire Feeder	59
14-3. Typical MIG Process Control Settings	60
14-4. Holding And Positioning Welding Gun	61
14-5. Conditions That Affect Weld Bead Shape	62
14-6. Gun Movement During Welding	63
14-7. Poor Weld Bead Characteristics	63
14-8. Good Weld Bead Characteristics	63
14-9. Troubleshooting – Excessive Spatter	64
14-10. Troubleshooting – Porosity	64
14-11. Troubleshooting – Excessive Penetration	64
14-12. Troubleshooting – Lack Of Penetration	65
14-13. Troubleshooting – Incomplete Fusion	65
14-14. Troubleshooting – Burn-Through	65
14-15. Troubleshooting – Waviness Of Bead	66
14-16. Troubleshooting – Distortion	66
14-17. Common MIG Shielding Gases	67
SECTION 15 – PARTS LIST	68

SECTION 1 – SAFETY PRECAUTIONS – READ BEFORE USING

rom_nd_8/03

▲ **Warning: Protect yourself and others from injury — read and follow these precautions.**

1-1. Symbol Usage



Means Warning! Watch Out! There are possible hazards with this procedure! The possible hazards are shown in the adjoining symbols.

▲ **Marks a special safety message.**

☞ Means “Note”; not safety related.



This group of symbols means Warning! Watch Out! possible ELECTRIC SHOCK, MOVING PARTS, and HOT PARTS hazards. Consult symbols and related instructions below for necessary actions to avoid the hazards.

1-2. Arc Welding Hazards

▲ **The symbols shown below are used throughout this manual to call attention to and identify possible hazards. When you see the symbol, watch out, and follow the related instructions to avoid the hazard. The safety information given below is only a summary of the more complete safety information found in the Safety Standards listed in Section 1-7. Read and follow all Safety Standards.**

▲ **Only qualified persons should install, operate, maintain, and repair this unit.**

▲ **During operation, keep everybody, especially children, away.**



ELECTRIC SHOCK can kill.

Touching live electrical parts can cause fatal shocks or severe burns. The electrode and work circuit is electrically live whenever the output is on. The input power circuit and machine internal circuits are also live when power is on. In semiautomatic or automatic wire welding, the wire, wire reel, drive roll housing, and all metal parts touching the welding wire are electrically live. Incorrectly installed or improperly grounded equipment is a hazard.

- Do not touch live electrical parts.
- Wear dry, hole-free insulating gloves and body protection.
- Insulate yourself from work and ground using dry insulating mats or covers big enough to prevent any physical contact with the work or ground.
- Do not use AC output in damp areas, if movement is confined, or if there is a danger of falling.
- Use AC output ONLY if required for the welding process.
- If AC output is required, use remote output control if present on unit.
- Additional safety precautions are required when any of the following electrically hazardous conditions are present: in damp locations or while wearing wet clothing; on metal structures such as floors, gratings, or scaffolds; when in cramped positions such as sitting, kneeling, or lying; or when there is a high risk of unavoidable or accidental contact with the workpiece or ground. For these conditions, use the following equipment in order presented: 1) a semiautomatic DC constant voltage (wire) welder, 2) a DC manual (stick) welder, or 3) an AC welder with reduced open-circuit voltage. In most situations, use of a DC, constant voltage wire welder is recommended. And, do not work alone!
- Disconnect input power or stop engine before installing or servicing this equipment. Lockout/tagout input power according to OSHA 29 CFR 1910.147 (see Safety Standards).
- Properly install and ground this equipment according to its Owner's Manual and national, state, and local codes.
- Always verify the supply ground — check and be sure that input power cord ground wire is properly connected to ground terminal in disconnect box or that cord plug is connected to a properly grounded receptacle outlet.
- When making input connections, attach proper grounding conductor first — double-check connections.
- Frequently inspect input power cord for damage or bare wiring — replace cord immediately if damaged — bare wiring can kill.
- Turn off all equipment when not in use.
- Do not use worn, damaged, undersized, or poorly spliced cables.
- Do not drape cables over your body.
- If earth grounding of the workpiece is required, ground it directly with a separate cable.
- Do not touch electrode if you are in contact with the work, ground, or another electrode from a different machine.

- Use only well-maintained equipment. Repair or replace damaged parts at once. Maintain unit according to manual.
- Wear a safety harness if working above floor level.
- Keep all panels and covers securely in place.
- Clamp work cable with good metal-to-metal contact to workpiece or worktable as near the weld as practical.
- Insulate work clamp when not connected to workpiece to prevent contact with any metal object.
- Do not connect more than one electrode or work cable to any single weld output terminal.

SIGNIFICANT DC VOLTAGE exists in inverters after stopping engine.

- Stop engine on inverter and discharge input capacitors according to instructions in Maintenance Section before touching any parts.



FUMES AND GASES can be hazardous.

Welding produces fumes and gases. Breathing these fumes and gases can be hazardous to your health.

- Keep your head out of the fumes. Do not breathe the fumes.
- If inside, ventilate the area and/or use exhaust at the arc to remove welding fumes and gases.
- If ventilation is poor, use an approved air-supplied respirator.
- Read the Material Safety Data Sheets (MSDSs) and the manufacturer's instructions for metals, consumables, coatings, cleaners, and degreasers.
- Work in a confined space only if it is well ventilated, or while wearing an air-supplied respirator. Always have a trained watchperson nearby. Welding fumes and gases can displace air and lower the oxygen level causing injury or death. Be sure the breathing air is safe.
- Do not weld in locations near degreasing, cleaning, or spraying operations. The heat and rays of the arc can react with vapors to form highly toxic and irritating gases.
- Do not weld on coated metals, such as galvanized, lead, or cadmium plated steel, unless the coating is removed from the weld area, the area is well ventilated, and if necessary, while wearing an air-supplied respirator. The coatings and any metals containing these elements can give off toxic fumes if welded.



BUILDUP OF GAS can injure or kill.

- Shut off shielding gas supply when not in use.
- Always ventilate confined spaces or use approved air-supplied respirator.

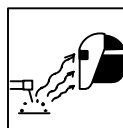

ARC RAYS can burn eyes and skin.

Arc rays from the welding process produce intense visible and invisible (ultraviolet and infrared) rays that can burn eyes and skin. Sparks fly off from the weld.

- Wear a welding helmet fitted with a proper shade of filter to protect your face and eyes from arc rays and sparks when welding or watching (see ANSI Z49.1 and Z87.1 listed in Safety Standards).
- Wear approved safety glasses with side shields under your helmet.
- Use protective screens or barriers to protect others from flash and glare; warn others not to watch the arc.
- Wear protective clothing made from durable, flame-resistant material (wool and leather) and foot protection.



WELDING can cause fire or explosion.

Welding on closed containers, such as tanks, drums, or pipes, can cause them to blow up. Sparks can fly off from the welding arc. The flying sparks, hot workpiece, and hot equipment can cause fires and burns. Accidental contact of electrode to metal objects can cause sparks, explosion, overheating, or fire. Check and be sure the area is safe before doing any welding.

- Protect yourself and others from flying sparks and hot metal.
- Do not weld where flying sparks can strike flammable material.
- Remove all flammables within 35 ft (10.7 m) of the welding arc. If this is not possible, tightly cover them with approved covers.
- Be alert that welding sparks and hot materials from welding can easily go through small cracks and openings to adjacent areas.
- Watch for fire, and keep a fire extinguisher nearby.
- Be aware that welding on a ceiling, floor, bulkhead, or partition can cause fire on the hidden side.
- Do not weld on closed containers such as tanks, drums, or pipes, unless they are properly prepared according to AWS F4.1 (see Safety Standards).
- Connect work cable to the work as close to the welding area as practical to prevent welding current from traveling long, possibly unknown paths and causing electric shock and fire hazards.
- Do not use welder to thaw frozen pipes.
- Remove stick electrode from holder or cut off welding wire at contact tip when not in use.
- Wear oil-free protective garments such as leather gloves, heavy shirt, cuffless trousers, high shoes, and a cap.
- Remove any combustibles, such as a butane lighter or matches, from your person before doing any welding.
- Follow requirements in OSHA 1910.252 (a) (2) (iv) and NFPA 51B for hot work and have a fire watcher and extinguisher nearby.

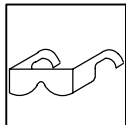

FLYING METAL can injure eyes.

- Welding, chipping, wire brushing, and grinding cause sparks and flying metal. As welds cool, they can throw off slag.
- Wear approved safety glasses with side shields even under your welding helmet.



HOT PARTS can cause severe burns.

- Allow cooling period before maintaining.
- Wear protective gloves and clothing when working on a hot engine.
- Do not touch hot engine parts or just-welded parts bare-handed.



NOISE can damage hearing.

Noise from some processes or equipment can damage hearing.

- Wear approved ear protection if noise level is high.



MAGNETIC FIELDS can affect pacemakers.

- Pacemaker wearers keep away.
- Wearers should consult their doctor before going near arc welding, gouging, or spot welding operations.

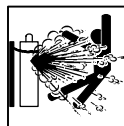

CYLINDERS can explode if damaged.

Shielding gas cylinders contain gas under high pressure. If damaged, a cylinder can explode. Since gas cylinders are normally part of the welding process, be sure to treat them carefully.

- Protect compressed gas cylinders from excessive heat, mechanical shocks, slag, open flames, sparks, and arcs.
- Install cylinders in an upright position by securing to a stationary support or cylinder rack to prevent falling or tipping.
- Keep cylinders away from any welding or other electrical circuits.
- Never drape a welding torch over a gas cylinder.
- Never allow a welding electrode to touch any cylinder.
- Never weld on a pressurized cylinder — explosion will result.
- Use only correct shielding gas cylinders, regulators, hoses, and fittings designed for the specific application; maintain them and associated parts in good condition.
- Turn face away from valve outlet when opening cylinder valve.
- Keep protective cap in place over valve except when cylinder is in use or connected for use.
- Read and follow instructions on compressed gas cylinders, associated equipment, and CGA publication P-1 listed in Safety Standards.

1-3. Engine Hazards



BATTERY EXPLOSION can BLIND.

- Always wear a face shield, rubber gloves, and protective clothing when working on a battery.
- Stop engine before disconnecting or connecting battery cables or servicing battery.
- Do not allow tools to cause sparks when working on a battery.
- Do not use welder to charge batteries or jump start vehicles.
- Observe correct polarity (+ and -) on batteries.
- Disconnect negative (-) cable first and connect it last.



FUEL can cause fire or explosion.

- Stop engine and let it cool off before checking or adding fuel.
- Do not add fuel while smoking or if unit is near any sparks or open flames.
- Do not overfill tank — allow room for fuel to expand.
- Do not spill fuel. If fuel is spilled, clean up before starting engine.
- Dispose of rags in a fireproof container.
- Always keep nozzle in contact with tank when fueling.



MOVING PARTS can cause injury.

- Keep away from fans, belts, and rotors.
- Keep all doors, panels, covers, and guards closed and securely in place.
- Stop engine before installing or connecting unit.
- Have only qualified people remove guards or covers for maintenance and troubleshooting as necessary.
- To prevent accidental starting during servicing, disconnect negative (-) battery cable from battery.
- Keep hands, hair, loose clothing, and tools away from moving parts.
- Reinstall panels or guards and close doors when servicing is finished and before starting engine.
- Before working on generator, remove spark plugs or injectors to keep engine from kicking back or starting.
- Block flywheel so that it will not turn while working on generator components.



STEAM AND HOT COOLANT can burn.

- If possible, check coolant level when engine is cold to avoid scalding.
- Always check coolant level at overflow tank, if present on unit, instead of radiator (unless told otherwise in maintenance section or engine manual).
- If the engine is warm, checking is needed, and there is no overflow tank, follow the next two statements.
- Wear safety glasses and gloves and put a rag over radiator cap.
- Turn cap slightly and let pressure escape slowly before completely removing cap.



ENGINE EXHAUST GASES can kill.

- Use equipment outside in open, well-ventilated areas.
- If used in a closed area, vent engine exhaust outside and away from any building air intakes.

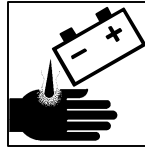

BATTERY ACID can BURN SKIN and EYES.

- Do not tip battery.
- Replace damaged battery.
- Flush eyes and skin immediately with water.

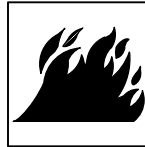

ENGINE HEAT can cause fire.

- Do not locate unit on, over, or near combustible surfaces or flammables.
- Keep exhaust and exhaust pipes way from flammables.



EXHAUST SPARKS can cause fire.

- Do not let engine exhaust sparks cause fire.
- Use approved engine exhaust spark arrestor in required areas — see applicable codes.

1-4. Compressed Air Hazards



BREATHING COMPRESSED AIR can cause serious injury or death.

- Do not use compressed air for breathing.
- Use only for cutting, gouging, and tools.

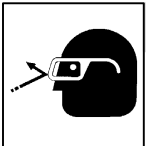

COMPRESSED AIR can cause injury.

- Wear approved safety goggles.
- Do not direct air stream toward self or others.



TRAPPED AIR PRESSURE AND WHIPPING HOSES can cause injury.

- Release air pressure from tools and system before servicing, adding or changing attachments, or opening compressor oil drain or oil fill cap.



HOT METAL from air arc cutting and gouging can cause fire or explosion.

- Do not cut or gouge near flammables.
- Watch for fire; keep extinguisher nearby.



HOT PARTS can cause burns and injury.

- Do not touch hot compressor or air system parts.
- Let system cool down before touching or servicing.

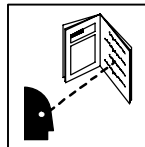

READ INSTRUCTIONS.

- Read Owner's Manual before using or servicing unit.
- Stop engine and release air pressure before servicing.

1-5. Additional Symbols For Installation, Operation, And Maintenance



FALLING UNIT can cause injury.

- Use lifting eye to lift unit only, NOT running gear, gas cylinders, trailer, or any other accessories.
- Use equipment of adequate capacity to lift and support unit.
- If using lift forks to move unit, be sure forks are long enough to extend beyond opposite side of unit.

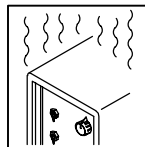

OVERUSE can cause OVERHEATING.

- Allow cooling period; follow rated duty cycle.
- Reduce current or reduce duty cycle before starting to weld again.
- Do not block or filter airflow to unit.

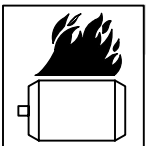

OVERHEATING can damage motors.

- Turn off or unplug equipment before starting or stopping engine.
- Do not let low voltage and frequency caused by low engine speed damage electric motors.
- Do not connect 50 or 60 Hertz motors to the 100 Hertz receptacle where applicable.

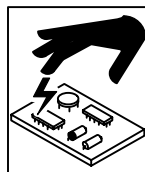

STATIC (ESD) can damage PC boards.

- Put on grounded wrist strap BEFORE handling boards or parts.
- Use proper static-proof bags and boxes to store, move, or ship PC boards.

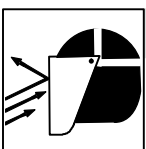

FLYING SPARKS can cause injury.

- Wear a face shield to protect eyes and face.
- Shape tungsten electrode only on grinder with proper guards in a safe location wearing proper face, hand, and body protection.
- Sparks can cause fires — keep flammables away.



TILTING OF TRAILER can cause injury.

- Use tongue jack or blocks to support weight.
- Properly install welding generator onto trailer according to instructions supplied with trailer.

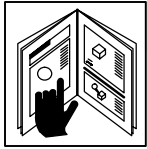

READ INSTRUCTIONS.

- Use only genuine MILLER/Hobart replacement parts.
- Perform engine and air compressor (if applicable) maintenance and service according to this manual and the engine/air compressor (if applicable) manuals.

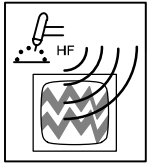

H.F. RADIATION can cause interference.

- High-frequency (H.F.) can interfere with radio navigation, safety services, computers, and communications equipment.
- Have only qualified persons familiar with electronic equipment perform this installation.
- The user is responsible for having a qualified electrician promptly correct any interference problem resulting from the installation.
- If notified by the FCC about interference, stop using the equipment at once.
- Have the installation regularly checked and maintained.
- Keep high-frequency source doors and panels tightly shut, keep spark gaps at correct setting, and use grounding and shielding to minimize the possibility of interference.

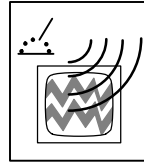

ARC WELDING can cause interference.

- Electromagnetic energy can interfere with sensitive electronic equipment such as microprocessors, computers, and computer-driven equipment such as robots.
- Be sure all equipment in the welding area is electromagnetically compatible.
- To reduce possible interference, keep weld cables as short as possible, close together, and down low, such as on the floor.
- Locate welding operation 100 meters from any sensitive electronic equipment.
- Be sure this welding machine is installed and grounded according to this manual.
- If interference still occurs, the user must take extra measures such as moving the welding machine, using shielded cables, using line filters, or shielding the work area.

1-6. California Proposition 65 Warnings

- ▲ **Welding or cutting equipment produces fumes or gases which contain chemicals known to the State of California to cause birth defects and, in some cases, cancer. (California Health & Safety Code Section 25249.5 et seq.)**
- ▲ **Battery posts, terminals and related accessories contain lead and lead compounds, chemicals known to the State of California to cause cancer and birth defects or other reproductive harm. Wash hands after handling.**

For Gasoline Engines:

- ▲ **Engine exhaust contains chemicals known to the State of California to cause cancer, birth defects, or other reproductive harm.**

For Diesel Engines:

- ▲ **Diesel engine exhaust and some of its constituents are known to the State of California to cause cancer, birth defects, and other reproductive harm.**

1-7. Principal Safety Standards

Safety in Welding, Cutting, and Allied Processes, ANSI Standard Z49.1, from American Welding Society, 550 N.W. LeJeune Rd, Miami FL 33126 (phone: 305-443-9353, website: www.aws.org).

Recommended Safe Practices for the Preparation for Welding and Cutting of Containers and Piping, American Welding Society Standard AWS F4.1, from American Welding Society, 550 N.W. LeJeune Rd, Miami, FL 33126 (phone: 305-443-9353, website: www.aws.org).

National Electrical Code, NFPA Standard 70, from National Fire Protection Association, P.O. Box 9101, 1 Battery March Park, Quincy, MA 02269-9101 (phone: 617-770-3000, website: www.nfpa.org and www.sparky.org).

Safe Handling of Compressed Gases in Cylinders, CGA Pamphlet P-1, from Compressed Gas Association, 1735 Jefferson Davis Highway, Suite 1004, Arlington, VA 22202-4102 (phone: 703-412-0900, website: www.cganet.com).

Code for Safety in Welding and Cutting, CSA Standard W117.2, from Canadian Standards Association, Standards Sales, 178 Rexdale Bou-

levard, Rexdale, Ontario, Canada M9W 1R3 (phone: 800-463-6727 or in Toronto 416-747-4044, website: www.csa-international.org).

Practice For Occupational And Educational Eye And Face Protection, ANSI Standard Z87.1, from American National Standards Institute, 11 West 42nd Street, New York, NY 10036-8002 (phone: 212-642-4900, website: www.ansi.org).

Standard for Fire Prevention During Welding, Cutting, and Other Hot Work, NFPA Standard 51B, from National Fire Protection Association, P.O. Box 9101, 1 Battery March Park, Quincy, MA 02269-9101 (phone: 617-770-3000, website: www.nfpa.org and www.sparky.org).

OSHA, Occupational Safety and Health Standards for General Industry, Title 29, Code of Federal Regulations (CFR), Part 1910, Subpart Q, and Part 1926, Subpart J, from U.S. Government Printing Office, Superintendent of Documents, P.O. Box 371954, Pittsburgh, PA 15250 (there are 10 Regional Offices—phone for Region 5, Chicago, is 312-353-2220, website: www.osha.gov).

1-8. EMF Information

Considerations About Welding And The Effects Of Low Frequency Electric And Magnetic Fields

Welding current, as it flows through welding cables, will cause electromagnetic fields. There has been and still is some concern about such fields. However, after examining more than 500 studies spanning 17 years of research, a special blue ribbon committee of the National Research Council concluded that: "The body of evidence, in the committee's judgment, has not demonstrated that exposure to power-frequency electric and magnetic fields is a human-health hazard." However, studies are still going forth and evidence continues to be examined. Until the final conclusions of the research are reached, you may wish to minimize your exposure to electromagnetic fields when welding or cutting.

To reduce magnetic fields in the workplace, use the following procedures:

1. Keep cables close together by twisting or taping them.
2. Arrange cables to one side and away from the operator.
3. Do not coil or drape cables around your body.
4. Keep welding power source and cables as far away from operator as practical.
5. Connect work clamp to workpiece as close to the weld as possible.

About Pacemakers:

Pacemaker wearers consult your doctor first. If cleared by your doctor, then following the above procedures is recommended.

SECTION 2 – CONSIGNES DE SÉCURITÉ – LIRE AVANT UTILISATION

rom_fre 8/03

▲ Avertissement: Protégez vous et les autres des blessures – lisez et suivez ces précautions.

2-1. Signification des symboles



Signifie Mise en garde ! Soyez vigilant ! Cette procédure présente des risques de danger ! Ceux-ci sont identifiés par des symboles adjacents aux directives.

▲ Identifie un message de sécurité particulier.

Signifie NOTA ; n'est pas relatif à la sécurité.



Ce groupe de symboles signifie Mise en garde ! Soyez vigilant ! Il y a des risques de danger reliés aux CHOCs ÉLECTRIQUES, aux PIÈCES EN MOUVEMENT et aux PIÈCES CHAUDES. Reportez-vous aux symboles et aux directives ci-dessous afin de connaître les mesures à prendre pour éviter tout danger.

2-2. Dangers relatifs au soudage à l'arc

▲ Les symboles présentés ci-après sont utilisés tout au long du présent manuel pour attirer votre attention et identifier les risques de danger. Lorsque vous voyez un symbole, soyez vigilant et suivez les directives mentionnées afin d'éviter tout danger. Les consignes de sécurité présentées ci-après ne font que résumer l'information contenue dans les normes de sécurité énumérées à la section 2-6. Veuillez lire et respecter toutes ces normes de sécurité.

▲ L'installation, l'utilisation, l'entretien et les réparations ne doivent être confiés qu'à des personnes qualifiées.

▲ Au cours de l'utilisation, tenir toute personne à l'écart et plus particulièrement les enfants.



UN CHOC ÉLECTRIQUE peut tuer.

Un simple contact avec des pièces électriques peut provoquer une électrocution ou des blessures graves. L'électrode et le circuit de soudage sont sous tension dès que l'appareil est sur ON. Le circuit d'entrée et les circuits internes de l'appareil sont également sous tension à ce moment-là. En soudage semi-automatique ou automatique, le fil, le dévidoir, le logement des galets d'entraînement et les pièces métalliques en contact avec le fil de soudage sont sous tension. Des matériels mal installés ou mal mis à la terre présentent un danger.

- Ne jamais toucher les pièces électriques sous tension.
- Porter des gants et des vêtements de protection secs ne comportant pas de trous.
- S'isoler de la pièce et de la terre au moyen de tapis ou d'autres moyens isolants suffisamment grands pour empêcher le contact physique éventuel avec la pièce ou la terre.
- Ne pas se servir de source électrique à courant électrique dans les zones humides, dans des endroits confinés ou là où on risque de tomber.
- Se servir d'une source électrique à courant électrique UNIQUEMENT si le procédé de soudage le demande.
- Si l'utilisation d'une source électrique à courant électrique s'avère nécessaire, se servir de la fonction de télécommande si l'appareil en est équipé.
- Des précautions de sécurité supplémentaires sont requises dans des environnements à risque comme: les endroits humides ou lorsque l'on porte des vêtements mouillés; sur des structures métalliques au sol, grillages et échafaudages; dans des positions assises, à genoux et allongées; ou quand il y a un risque important de contact accidentel avec la pièce ou le sol. Dans ces cas utiliser les appareils suivants dans l'ordre de préférence: 1) un poste à souder DC semi-automatique de type CV (MIG/MAG), 2) un poste à souder manuel (électrode enrobée) DC, 3) un poste à souder manuel AC avec tension à vide réduite. Dans la plupart des cas, un poste courant continu de type CV est recommandé. Et, ne pas travailler seul!
- Couper l'alimentation ou arrêter le moteur avant de procéder à l'installation, à la réparation ou à l'entretien de l'appareil. Déverrouiller l'alimentation selon la norme OSHA 29 CFR 1910.147 (voir normes de sécurité).
- Installer et mettre à la terre correctement cet appareil conformément à son manuel d'utilisation et aux codes nationaux, provinciaux et municipaux.
- Toujours vérifier la terre du cordon d'alimentation – Vérifier et s'assurer que le fil de terre du cordon d'alimentation est bien raccordé à la borne de terre du sectionneur ou que la fiche du cordon est raccordée à une prise correctement mise à la terre.

- En effectuant les raccordements d'entrée fixer d'abord le conducteur de mise à la terre approprié et contre-vérifier les connexions.
- Vérifier fréquemment le cordon d'alimentation pour voir s'il n'est pas endommagé ou dénudé – remplacer le cordon immédiatement s'il est endommagé – un câble dénudé peut provoquer une électrocution.
- Mettre l'appareil hors tension quand on ne l'utilise pas.
- Ne pas utiliser des câbles usés, endommagés, de grosseur insuffisante ou mal épissés.
- Ne pas enrouler les câbles autour du corps.
- Si la pièce soudée doit être mise à la terre, le faire directement avec un câble distinct – ne pas utiliser le connecteur de pièce ou le câble de retour.
- Ne pas toucher l'électrode quand on est en contact avec la pièce, la terre ou une électrode provenant d'une autre machine.
- N'utiliser qu'un matériel en bon état. Réparer ou remplacer sur-le-champ les pièces endommagées. Entretien l'appareil conformément à ce manuel.
- Porter un harnais de sécurité quand on travaille en hauteur.
- Maintenir solidement en place tous les panneaux et capots.
- Fixer le câble de retour de façon à obtenir un bon contact métal-métal avec la pièce à souder ou la table de travail, le plus près possible de la soudure.
- Isoler la pince de masse quand pas mis à la pièce pour éviter le contact avec tout objet métallique.

Une tension DC importante subsiste à l'intérieur des onduleurs après avoir coupé l'alimentation.

- Couper l'alimentation du poste et décharger les condensateurs d'entrée comme indiqué dans la Section Maintenance avant de toucher des composants.

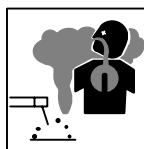

LES FUMÉES ET LES GAZ peuvent être dangereux.

Le soudage génère des fumées et des gaz. Leur inhalation peut être dangereuse pour votre santé.

- Eloigner votre tête des fumées. Ne pas respirer les fumées.
- À l'intérieur, ventiler la zone et/ou utiliser un échappement au niveau de l'arc pour l'évacuation des fumées et des gaz de soudage.
- Si la ventilation est insuffisante, utiliser un respirateur à alimentation d'air homologué.
- Lire les spécifications de sécurité des matériaux (MSDSs) et les instructions du fabricant concernant les métaux, les consommables, les revêtements, les nettoyeurs et les dégraisseurs.
- Travailler dans un espace fermé seulement s'il est bien ventilé ou en portant un respirateur à alimentation d'air. Demander toujours à un surveillant dûment formé de se tenir à proximité. Des fumées et des gaz de soudage peuvent déplacer l'air et abaisser le niveau d'oxygène provoquant des blessures ou des accidents mortels. S'assurer que l'air de respiration ne présente aucun danger.
- Ne pas souder dans des endroits situés à proximité d'opérations de dégraissage, de nettoyage ou de pulvérisation. La chaleur et les rayons de l'arc peuvent réagir en présence de vapeurs et former des gaz hautement toxiques et irritants.
- Ne pas souder des métaux munis d'un revêtement, tels que l'acier galvanisé, plaqué en plomb ou au cadmium à moins que le revêtement n'ait été enlevé dans la zone de soudure, que l'endroit soit bien ventilé, et si nécessaire, en portant un respirateur à alimentation d'air. Les revêtements et tous les métaux renfermant ces éléments peuvent dégager des fumées toxiques en cas de soudage.



LES ACCUMULATIONS DE GAZ risquent de provoquer des blessures ou même la mort.

- Fermer l'alimentation du gaz protecteur en cas de non utilisation.
- Veiller toujours à bien aérer les espaces confinés ou se servir d'un respirateur d'adduction d'air homologué.

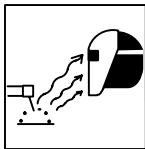

LES RAYONS DE L'ARC peuvent provoquer des brûlures dans les yeux et sur la peau.

Le rayonnement de l'arc du procédé de soudage génère des rayons visibles et invisibles intenses (ultraviolets et infrarouges) susceptibles de provoquer des brûlures dans les yeux et sur la peau. Des étincelles sont projetées pendant le soudage.

- Porter un casque de soudage muni d'un écran de filtre approprié pour protéger votre visage et vos yeux pendant le soudage ou pour regarder (voir ANSI Z49.1 et Z87.1 énuméré dans les normes de sécurité).
- Porter des protections approuvés pour les oreilles si le niveau sonore est trop élevé.
- Utiliser des écrans ou des barrières pour protéger des tiers de l'éclair et de l'éblouissement; demander aux autres personnes de ne pas regarder l'arc.
- Porter des vêtements de protection constitué dans une matière durable, résistant au feu (laine ou cuir) et une protection des pieds.



LE SOUDAGE peut provoquer un incendie ou une explosion.

Le soudage effectué sur des conteneurs fermés tels que des réservoirs, tambours ou des conduites peut provoquer leur éclatement. Des étincelles peuvent être projetées de l'arc de soudure. La projection d'étincelles, des pièces chaudes et des équipements chauds peut provoquer des incendies et des brûlures. Le contact accidentel de l'électrode avec des objets métalliques peut provoquer des étincelles, une explosion, un surchauffement ou un incendie. Avant de commencer le soudage, vérifier et s'assurer que l'endroit ne présente pas de danger.

- Se protéger et d'autres personnes de la projection d'étincelles et de métal chaud.
- Ne pas souder dans un endroit là où des étincelles peuvent tomber sur des substances inflammables.
- Déplacer toutes les substances inflammables à une distance de 10,7 m de l'arc de soudage. En cas d'impossibilité les recouvrir soigneusement avec des protections homologués.
- Des étincelles et des matériaux chauds du soudage peuvent facilement passer dans d'autres zones en traversant de petites fissures et des ouvertures.
- Surveiller tout déclenchement d'incendie et tenir un extincteur à proximité.
- Le soudage effectué sur un plafond, plancher, paroi ou séparation peut déclencher un incendie de l'autre côté.
- Ne pas effectuer le soudage sur des conteneurs fermés tels que des réservoirs, tambours, ou conduites, à moins qu'ils n'aient été préparés correctement conformément à AWS F4.1 (voir les normes de sécurité).
- Brancher le câble sur la pièce le plus près possible de la zone de soudage pour éviter le transport du courant sur une longue distance par des chemins inconnus éventuels en provoquant des risques d'électrocution et d'incendie.
- Ne pas utiliser le poste de soudage pour dégeler des conduites gelées.
- En cas de non utilisation, enlever la baguette d'électrode du porte-électrode ou couper le fil à la pointe de contact.
- Porter des vêtements de protection dépourvus d'huile tels que des gants en cuir, une chemise en matériau lourd, des pantalons sans revers, des chaussures hautes et un couvre chef.
- Avant de souder, retirer toute substance combustible de vos poches telles qu'un allumeur au butane ou des allumettes.

2-3. Dangers existant en relation avec le moteur



LES ACCUMULATIONS DE GAZ risquent de provoquer des blessures ou même la mort.

- Fermer l'alimentation du gaz protecteur en cas de non utilisation.
- Veiller toujours à bien aérer les espaces confinés ou se servir d'un respirateur d'adduction d'air homologué.

- Suivre les recommandations dans OSHA 1910.252(a)(2)(iv) et NFPA 51B pour les travaux à chaud et avoir de la surveillance et un extincteur à proximité.

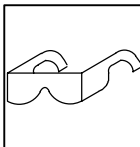

DES PARTICULES VOLANTES peuvent blesser les yeux.

- Le soudage, l'écaillage, le passage de la pièce à la brosse en fil de fer, et le meulage génèrent des étincelles et des particules métalliques volantes. Pendant la période de refroidissement des soudures, elles risquent de projeter du laitier.

- Porter des lunettes de sécurité avec écrans latéraux ou un écran facial.



DES PIÈCES CHAUDES peuvent provoquer des brûlures graves.

- Prévoir une période de refroidissement avant d'effectuer des travaux d'entretien.
- Porter des gants et des vêtements de protection pour travailler sur un moteur chaud.

- Ne pas toucher à mains nues les parties chaudes du moteur ni les pièces récemment soudées.

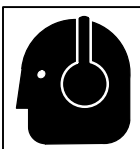

LE BRUIT peut affecter l'ouïe.

Le bruit des processus et des équipements peut affecter l'ouïe.

- Porter des protections approuvés pour les oreilles si le niveau sonore est trop élevé.



LES CHAMPS MAGNÉTIQUES peuvent affecter les stimulateurs cardiaques.

- Porteurs de stimulateur cardiaque, restez à distance.
- Les porteurs d'un stimulateur cardiaque doivent d'abord consulter leur médecin avant de s'approcher des opérations de soudage à l'arc, de gougeage ou de soudage par points.

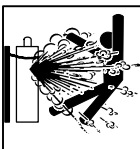

Si des BOUTEILLES sont endommagées, elles pourront exploser.

Des bouteilles de gaz protecteur contiennent du gaz sous haute pression. Si une bouteille est endommagée, elle peut exploser. Du fait que les bouteilles de gaz font normalement partie du procédé de soudage, les manipuler avec précaution.

- Protéger les bouteilles de gaz comprimé d'une chaleur excessive, des chocs mécaniques, du laitier, des flammes ouvertes, des étincelles et des arcs.
- Placer les bouteilles debout en les fixant dans un support stationnaire ou dans un porte-bouteilles pour les empêcher de tomber ou de se renverser.
- Tenir les bouteilles éloignées des circuits de soudage ou autres circuits électriques.
- Ne jamais placer une torche de soudage sur une bouteille à gaz.
- Une électrode de soudage ne doit jamais entrer en contact avec une bouteille.
- Ne jamais souder une bouteille pressurisée – risque d'explosion.
- Utiliser seulement des bouteilles de gaz protecteur, régulateurs, tuyaux et raccords convenables pour cette application spécifique; les maintenir ainsi que les éléments associés en bon état.
- Ne pas tenir la tête en face de la sortie en ouvrant la soupape de la bouteille.
- Maintenir le chapeau de protection sur la soupape, sauf en cas d'utilisation ou de branchement de la bouteille.
- Lire et suivre les instructions concernant les bouteilles de gaz comprimé, les équipements associés et les publication P-1 CGA énumérées dans les normes de sécurité.



L'ACIDE DE LA BATTERIE peut provoquer des brûlures dans les YEUX et sur la PEAU.

- Ne pas renverser la batterie.
- Remplacer une batterie endommagée.
- Rincer immédiatement les yeux et la peau à l'eau.



L'EXPLOSION DE LA BATTERIE peut RENDRE AVEUGLE.

- Toujours porter une protection faciale, des gants en caoutchouc et vêtements de protection lors d'une intervention sur la batterie.

- Arrêter le moteur avant de débrancher ou de brancher les câbles de batterie.
- Eviter de provoquer des étincelles avec les outils en travaillant sur la batterie.
- Ne pas utiliser le poste de soudage pour charger les batteries ou des véhicules de démarrage rapide.
- Observer la polarité correcte (+ et -) sur les batteries.
- Débrancher le câble négatif (-) en premier lieu. Le rebrancher en dernier lieu.



LE CARBURANT MOTEUR peut provoquer un incendie ou une explosion.

- Arrêter le moteur avant de vérifier le niveau de carburant ou de faire le plein.
- Ne pas faire le plein en fumant ou proche d'une source d'étincelles ou d'une flamme nue.

- Ne pas faire le plein de carburant à ras bord; prévoir de l'espace pour son expansion.
- Faire attention de ne pas renverser de carburant. Nettoyer tout carburant renversé avant de faire démarrer le moteur.
- Jeter les chiffons dans un récipient ignifuge.



DES ORGANES MOBILES peuvent provoquer des blessures.

- Ne pas approcher les mains des ventilateurs, courroies et autres pièces en mouvement.
- Maintenir fermés et fixement en place les portes, panneaux, recouvrements et dispositifs de protection.

- Arrêter le moteur avant d'installer ou brancher l'appareil.
- Demander seulement à un personnel qualifié d'enlever les dispositifs de sécurité ou les recouvrements pour effectuer, s'il y a lieu, des travaux d'entretien et de dépannage.

2-4. Dangers liés à l'air comprimé



RESPIRER L'AIR COMPRIMÉ peut provoquer des blessures graves ou causer la mort.

- Ne pas utiliser l'air comprimé pour respirer.
- Utiliser l'air comprimé seulement pour le coupage, gougeage et les outils pneumatiques.

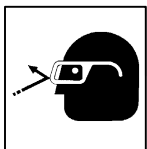

L'AIR COMPRIMÉ peut provoquer des blessures.

- Porter des lunettes de sécurité approuvées.
- Ne pas diriger le jet d'air vers d'autres ou soi-même.

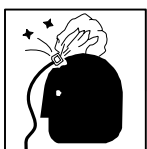

L'AIR COMPRIMÉ EMMAGASINE ET DES TUYAUX SOUS PRESSION peuvent provoquer des blessures.

- Relâcher la pression d'air de l'outillage ou du système avant d'effectuer la maintenance, avant de changer ou de rajouter des éléments ou avant d'ouvrir la purge ou le bouchon de remplissage d'huile.

- Pour empêcher tout démarrage accidentel pendant les travaux d'entretien, débrancher le câble négatif (-) de batterie de la borne.
- Ne pas approcher les mains, cheveux, vêtements lâches et outils des organes mobiles.
- Remettre en place les panneaux ou les dispositifs de protection et fermer les portes à la fin des travaux d'entretien et avant de faire démarrer le moteur.
- Avant d'intervenir, déposer les bougies ou injecteurs pour éviter la mise en route accidentelle du moteur.
- Bloquer le volant moteur pour éviter sa rotation lors d'une intervention sur le générateur.

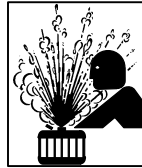

LA VAPEUR ET LE LIQUIDE DE REFROIDISSEMENT CHAUD peuvent provoquer des brûlures.

- Il est préférable de vérifier le liquide de refroidissement une fois le moteur refroidi pour éviter de se brûler.

- Toujours vérifier le niveau de liquide de refroidissement dans le vase d'expansion (si présent), et non dans le radiateur (sauf si précisé autrement dans la section maintenance du manuel du moteur).
- Si le moteur est chaud et que le liquide doit être vérifié, opérer comme suivant :
- Mettre des lunettes de sécurité et des gants, placer un torchon sur le bouchon du radiateur.
- Dévisser le bouchon légèrement et laisser la vapeur s'échapper avant d'enlever le bouchon.



LA CHALEUR DU MOTEUR peut provoquer un incendie.

- Ne pas placer l'appareil sur, au-dessus ou à proximité de surfaces inflammables.
- Tenir à distance les produits inflammables de l'échappement.



LES ÉTINCELLES À L'ÉCHAPPEMENT peuvent provoquer un incendie.

- Empêcher les étincelles d'échappement du moteur de provoquer un incendie.
- Utiliser uniquement un pare-étincelles approuvé – voir codes en vigueur.

2-5. Dangers supplémentaires en relation avec l'installation, le fonctionnement et la maintenance



LA CHUTE DE L'APPAREIL peut blesser.

- Utiliser l'anneau de levage uniquement pour soulever l'appareil lui-même ; sans chariot, de bouteilles de gaz, remorque, ou autres accessoires.

- Utiliser un équipement de levage de capacité suffisante pour lever l'appareil.
- En utilisant des fourches de levage pour déplacer l'unité, s'assurer que les fourches sont suffisamment longues pour dépasser du côté opposé de l'appareil.



LE SURCHAUFFEMENT peut endommager le moteur électrique.

- Arrêter ou déconnecter l'équipement avant de démarrer ou d'arrêter le moteur.
- Ne pas laisser tourner le moteur trop lentement sous risque d'endommager le moteur électrique à cause d'une tension et d'une fréquence trop faibles.
- Ne pas brancher de moteur de 50 ou de 60 Hz à la prise de 100 Hz, s'il y a lieu.

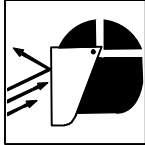

LES ÉTINCELLES VOLANTES risquent de provoquer des blessures.

- Porter un écran facial pour protéger le visage et les yeux.
- Affûter l'électrode au tungstène uniquement à la meuleuse dotée de protecteurs. Cette manoeuvre est à exécuter dans un endroit sûr lorsque l'on porte l'équipement homologué de protection du visage, des mains et du corps.
- Les étincelles risquent de causer un incendie – éloigner toute substance inflammable.

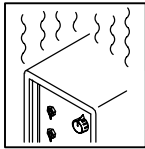

L'EMPLOI EXCESSIF peut SURCHAUFFER L'ÉQUIPEMENT.

- Laisser l'équipement refroidir ; respecter le facteur de marche nominal.
- Réduire le courant ou le facteur de marche avant de poursuivre le soudage.
- Ne pas obstruer les passages d'air du poste.

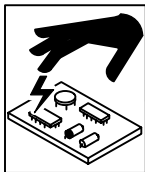

LES CHARGES ÉLECTROSTATIQUES peuvent endommager les circuits imprimés.

- Établir la connexion avec la barrette de terre avant de manipuler des cartes ou des pièces.
- Utiliser des pochettes et des boîtes antistatiques pour stocker, déplacer ou expédier des cartes de circuits imprimés.



UNE REMORQUE QUI BASCULE peut entraîner des blessures.

- Utiliser les supports de la remorque ou des blocs pour soutenir le poids.
- Installer convenablement le poste sur la remorque comme indiqué dans le manuel s'y rapportant.

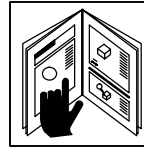

LIRE LES INSTRUCTIONS.

- Utiliser seulement les pièces de rechange d'origine.
- Effectuer la maintenance du moteur et du compresseur (si applicable) suivant ce manuel et le manuel du moteur/compresseur (si applicable).

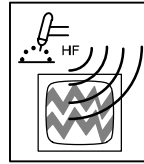

LE RAYONNEMENT HAUTE FRÉQUENCE (H.F.) risque de provoquer des interférences.

- Le rayonnement haute fréquence (H.F.) peut provoquer des interférences avec les équipements de radio-navigation et de communication, les services de sécurité et les ordinateurs.
- Demander seulement à des personnes qualifiées familiarisées avec des équipements électroniques de faire fonctionner l'installation.
- L'utilisateur est tenu de faire corriger rapidement par un électricien qualifié les interférences résultant de l'installation.
- Si le FCC signale des interférences, arrêter immédiatement l'appareil.
- Effectuer régulièrement le contrôle et l'entretien de l'installation.
- Maintenir soigneusement fermés les portes et les panneaux des sources de haute fréquence, maintenir les éclateurs à une distance correcte et utiliser une terre et un blindage pour réduire les interférences éventuelles.

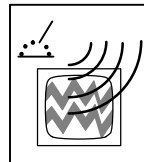

LE SOUDAGE À L'ARC risque de provoquer des interférences.

- L'énergie électromagnétique risque de provoquer des interférences pour l'équipement électronique sensible tel que les ordinateurs et l'équipement commandé par ordinateur tel que les robots.
- Veiller à ce que tout l'équipement de la zone de soudage soit compatible électromagnétiquement.
- Pour réduire la possibilité d'interférence, maintenir les câbles de soudage aussi courts que possible, les grouper, et les poser aussi bas que possible (ex. par terre).
- Veiller à souder à une distance de 100 mètres de tout équipement électronique sensible.
- Veiller à ce que ce poste de soudage soit posé et mis à la terre conformément à ce mode d'emploi.
- En cas d'interférences après avoir pris les mesures précédentes, il incombe à l'utilisateur de prendre des mesures supplémentaires telles que le déplacement du poste, l'utilisation de câbles blindés, l'utilisation de filtres de ligne ou la pose de protecteurs dans la zone de travail.

2-6. Principales normes de sécurité

Safety in Welding, Cutting, and Allied Processes, norme ANSI Z49.1, de l'American Welding Society, 550 N.W. LeJeune Rd, Miami FL 33126 (téléphone : (305) 443-9353, site Web : www.aws.org).

Recommended Safe Practices for the Preparation for Welding and Cutting of Containers and Piping, norme American Welding Society AWS F4.1, de l'American Welding Society, 550 N.W. LeJeune Rd, Miami, FL 33126 (téléphone : (305) 443-9353, site Web : www.aws.org).

National Electrical Code, norme NFPA 70, de la National Fire Protection Association, P.O. Box 9101, 1 Battery March Park, Quincy, MA 02269-9101 (téléphone : (617) 770-3000, sites Web : www.nfpa.org et www.sparky.org).

Safe Handling of Compressed Gases in Cylinders, brochure CGA P-1, de la Compressed Gas Association, 1735 Jefferson Davis Highway, Suite 1004, Arlington, VA 22202-4102 (téléphone : (703) 412-0900, site Web : www.cganet.com).

Code for Safety in Welding and Cutting, norme CSA W117.2, de la Canadian Standards Association, Standards Sales, 178 boulevard Rexdale,

Rexdale (Ontario) Canada M9W 1R3 (téléphone : (800) 463-6727 ou à Toronto : (416) 747-4044, site Web : www.csa-international.org).

Practice For Occupational And Educational Eye And Face Protection, norme ANSI Z87.1, de l'American National Standards Institute, 11 West 42nd Street, New York, NY 10036-8002 (téléphone : (212) 642-4900, site Web : www.ansi.org).

Standard for Fire Prevention During Welding, Cutting, and Other Hot Work, norme NFPA 51B, de la National Fire Protection Association, P.O. Box 9101, 1 Battery March Park, Quincy, MA 02269-9101 (téléphone : (617) 770-3000, site Web : www.nfpa.org et www.sparky.org).

OSHA, Occupational Safety and Health Standards for General Industry, Title 29, Code of Federal Regulations (CFR), Part 1910, Subpart Q, and Part 1926, Subpart J, de l'U.S. Government Printing Office, Superintendent of Documents, P.O. Box 371954, Pittsburgh, PA 15250 (il y a 10 bureaux régionaux – Téléphone pour la Région 5, Chicago : (312) 353-2220, site Web : www.osha.gov).

2-7. Information sur les champs électromagnétiques

Données sur le soudage électrique et les effets des champs magnétiques basse fréquence sur l'organisme

En parcourant les câbles de soudage, le courant crée des champs électromagnétiques. Les effets potentiels de tels champs restent préoccupants. Cependant, après avoir examiné plus de 500 études qui ont été faites pendant une période de recherche de 17 ans, un comité de spécialistes du National Research Council a conclu : « L'accumulation de preuves n'a pas démontré que l'exposition aux champs magnétiques et aux champs électriques à haute fréquence constitue un risque pour la santé humaine ». Toutefois, les études et l'examen des preuves se poursuivent. En attendant les conclusions finales de la recherche, il serait souhaitable de réduire l'exposition aux champs électromagnétiques pendant le soudage ou le coupage.

Afin de réduire les champs électromagnétiques en milieu de travail, respecter les consignes suivantes :

























1. Garder les câbles ensemble en les torsadant ou en les fixant avec du ruban adhésif.
2. Mettre tous les câbles du côté opposé à l'opérateur.
3. Ne pas s'enrouler les câbles autour du corps.
4. Garder le poste de soudage et les câbles le plus loin possible de soi.
5. Placer la pince de masse le plus près possible de la zone de soudage.

Consignes relatives aux stimulateurs cardiaques :

Les personnes qui portent un stimulateur cardiaque doivent avant tout consulter leur médecin. Si ce dernier les déclare aptes, il leur est recommandé de respecter les consignes ci-dessus.

SECTION 3 – DEFINITIONS

3-1. Symbol Definitions

	Stop Engine		Fast (Run, Weld/Power)		Fast/Slow (Run/Idle)		Slow (Idle)
	Start Engine		Read Operator's Manual	A	Amperes	V	Volts
	Engine Oil		Fuel		Battery (Engine)		Engine
	Engine Choke		Check Valve Clearance		Do not switch while welding		Work Connection
+	Positive	—	Negative		Alternating Current (AC)		Output
	Welding Arc (Electrode)		MIG (GMAW), Wire		Stick (SMAW)		TIG (GTAW)
h	Hours	s	Seconds		Time		Protective Earth (Ground)
	Circuit Breaker		Temperature				

SECTION 4 – SPECIFICATIONS

4-1. Weld, Power, and Engine Specifications

Note

This unit uses either a Robin EH-65 or a Kohler CH-20 engine. Differences between models are noted throughout this manual.

Welding Mode	Weld Output Range	Rated Welding Output	Maximum Open Circuit Voltage	Generator Power Rating	Fuel Capacity	Engine
CC/AC	40 – 250 A	250 A, 25 V, 100% Duty Cycle	80	Peak: 10 kVA/kW Continuous: 9.5 kVA/kW, Single-Phase, 84/42 A, 120/240 V AC, 60 Hz (while not welding)	12 gal (45 L) Tank	Robin EH-65 Air-Cooled, Two-Cylinder, Four-Cycle, 22 HP Gasoline Engine or Kohler CH-20 Air-Cooled, Two-Cylinder, Four-Cycle, 20 HP Gasoline Engine
CC/DC	40 – 250 A	250 A, 25 V, 100% Duty Cycle	72			
CV/DC	17 – 28 V	275 A, 25 V, 60% Duty Cycle 250 A, 28 V, 100% Duty Cycle	41			

4-2. Dimensions, Weights, and Operating Angles

Dimensions	
Height	33-1/2 in (851 mm) (To Top Of Exhaust)
Width	20 in (508 mm)
Depth	45-3/8 in (1153 mm)
A	20 in (508 mm)
B	16-1/2 in (419 mm)
C	1-3/4 in (44 mm)
D	6-1/16 in (154 mm)
E	32-3/4 in (832 mm)
F	45-3/8 in (1153 mm)
G	13/32 in (10 mm) Dia.
Weight	
Robin-Powered Unit:	560 lb (254 kg)
Kohler-Powered Unit:	562 lb (254 kg)

▲ Do not exceed tilt angles or engine could be damaged or unit could tip.

▲ Do not move or operate unit where it could tip.

4-3. Generator Power Curve

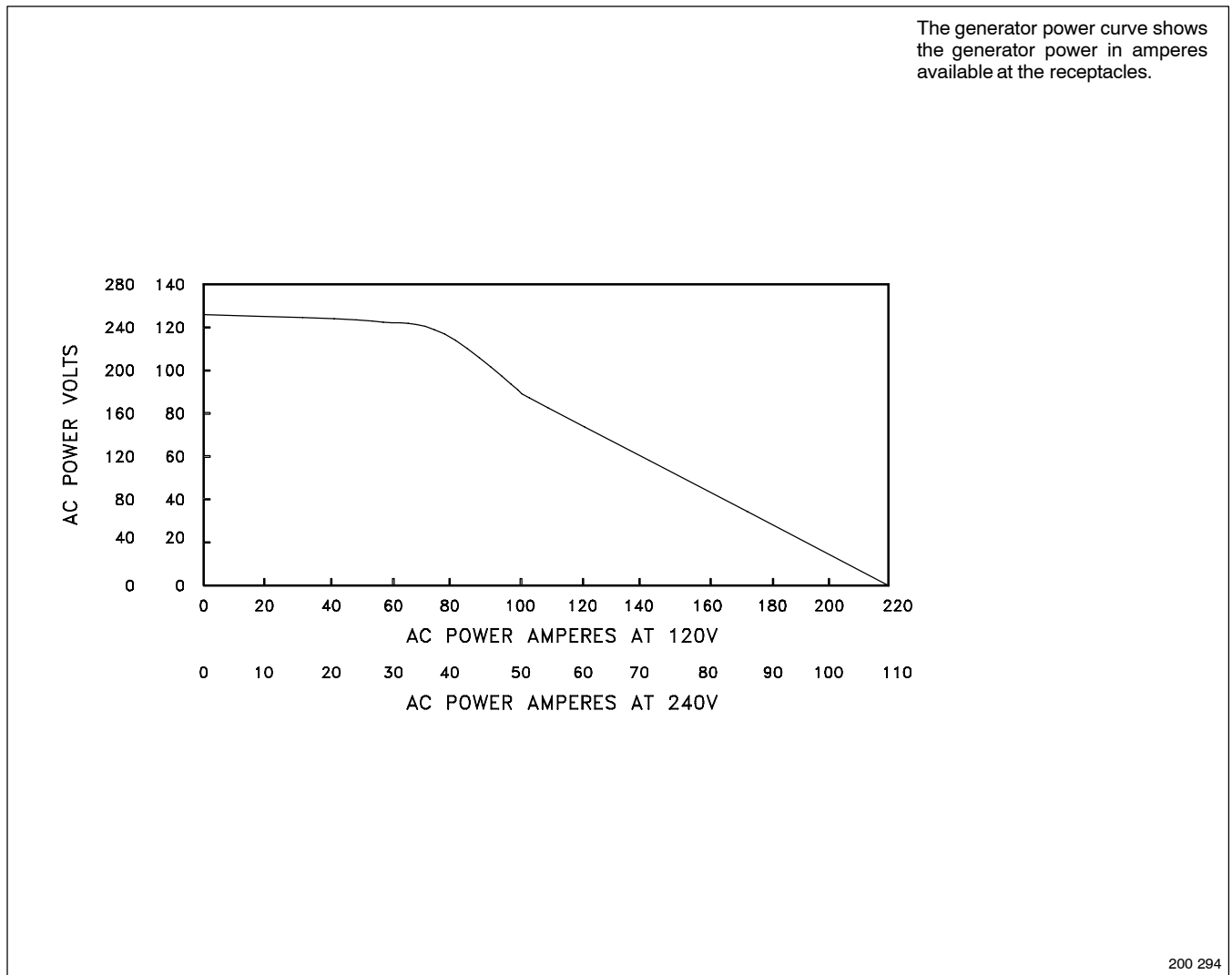

200 294

4-4. Fuel Consumption (Robin-Powered Units)

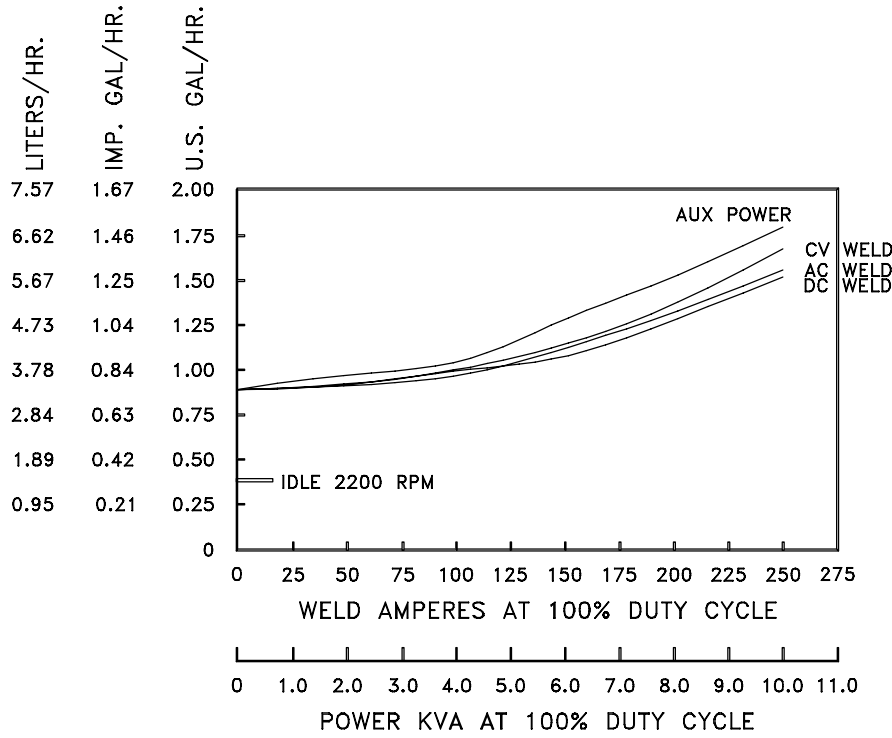

220 571

4-5. Fuel Consumption (Kohler-Powered Units)

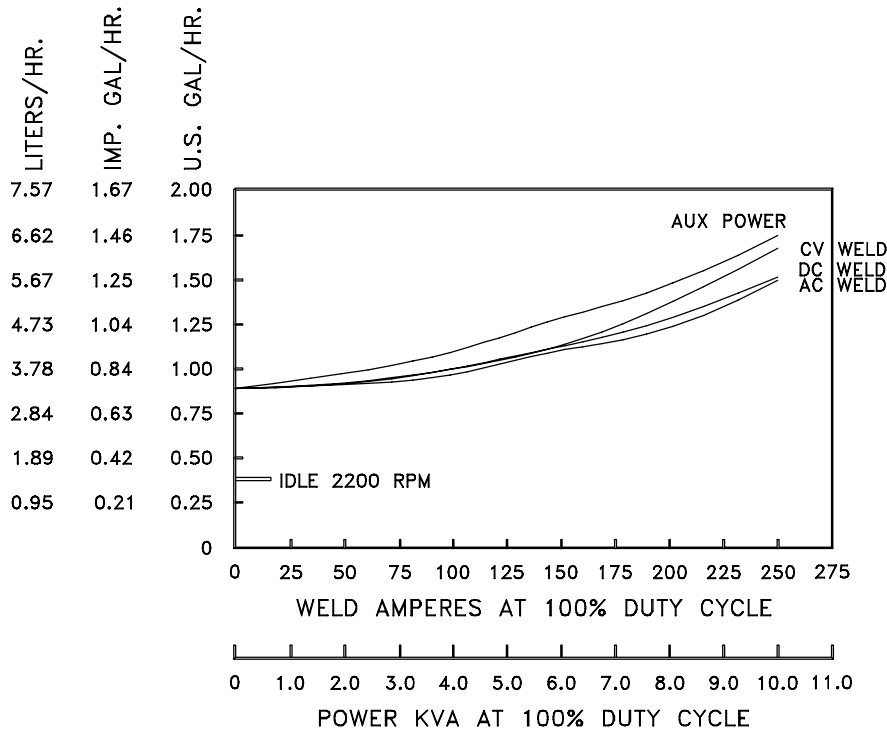

220 181

4-6. Volt-Ampere Curves

A. For CC/AC Mode

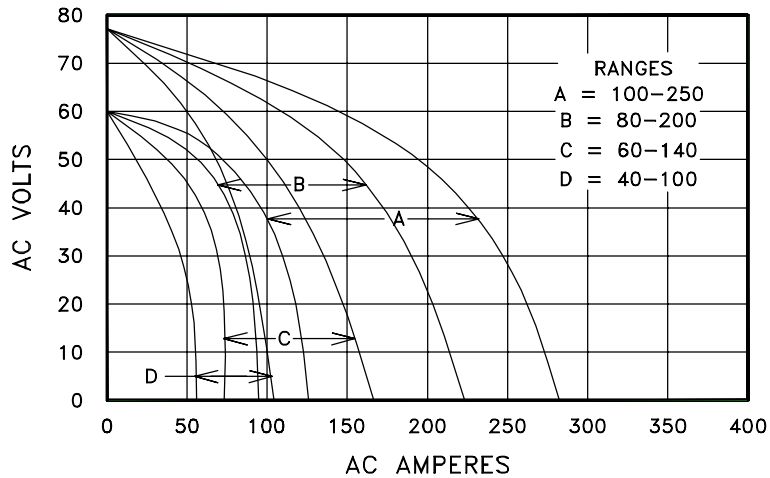

The volt-ampere curve shows the minimum and maximum voltage and amperage output capabilities of the welding generator. Curves of all other settings fall between the curves shown.

B. For CC/DC Mode

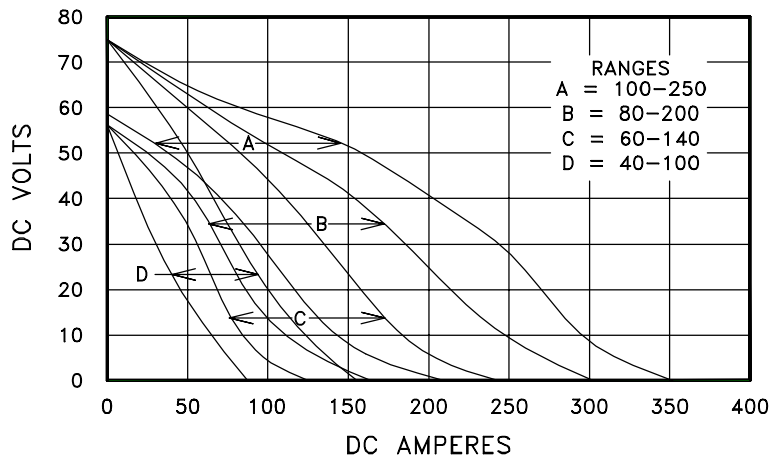

C. For CV/DC Mode

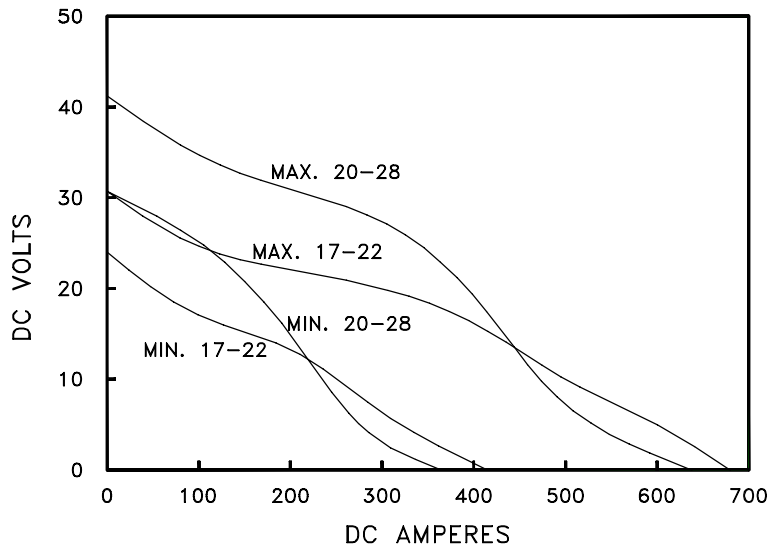

SECTION 5 – INSTALLATION

5-1. Installing Welding Generator



Movement

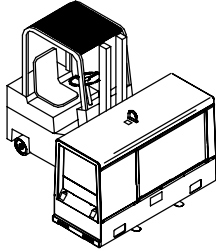

▲ Do not lift unit from end.

OR

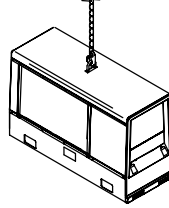

Location

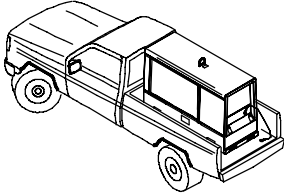

OR

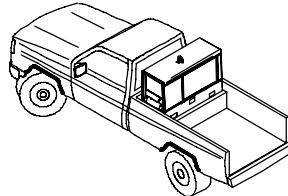

OR

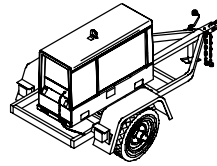

Mounting

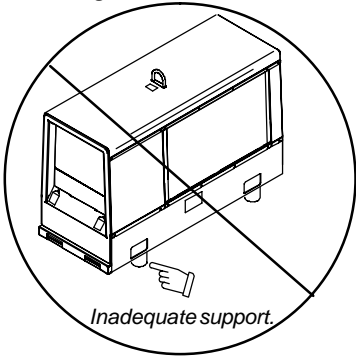

▲ Do not use flexible mounts.

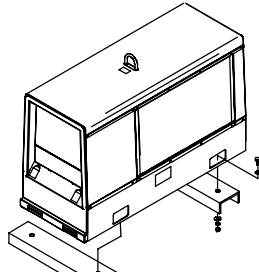

OR

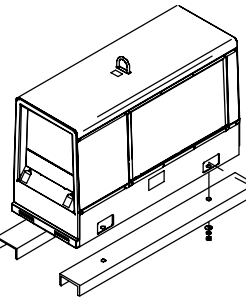

▲ Do not weld on base. Welding on base can cause fuel tank fire or explosion. Bolt unit down using holes provided in base.

▲ Always securely fasten welding generator onto transport vehicle or trailer and comply with all DOT and other applicable codes.

▲ Do not mount unit by supporting the base only at the four mounting holes. Use cross-supports to adequately support unit and prevent damage to base.

▲ Always ground generator frame to vehicle frame to prevent electric shock and static electricity hazards.

▲ If unit does not have GFCI receptacles, use GFCI-protected extension cord.

Mounting:

- 1 Cross-Supports

Mount unit on flat surface or use cross-supports to support base.

Grounding:

- 2 Equipment Grounding Terminal (On Front Panel)
- 3 Grounding Cable (Not Supplied)
- 4 Metal Vehicle Frame

Connect cable from equipment ground terminal to metal vehicle frame. Use #10 AWG or larger insulated copper wire.

Grounding

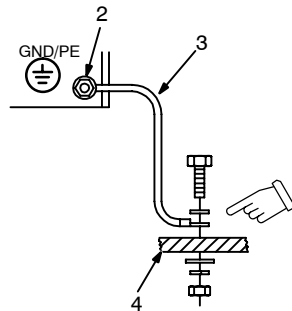

Electrically bond generator frame to vehicle frame by metal-to-metal contact.

▲ Bed liners, shipping skids, and some running gears insulate the welding generator from the vehicle frame. Always connect a ground wire from the generator equipment grounding terminal to bare metal on the vehicle frame as shown.

Airflow Clearance

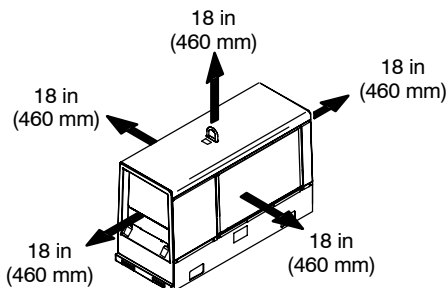

5-2. Engine Prestart Checks (Robin-Powered Units)

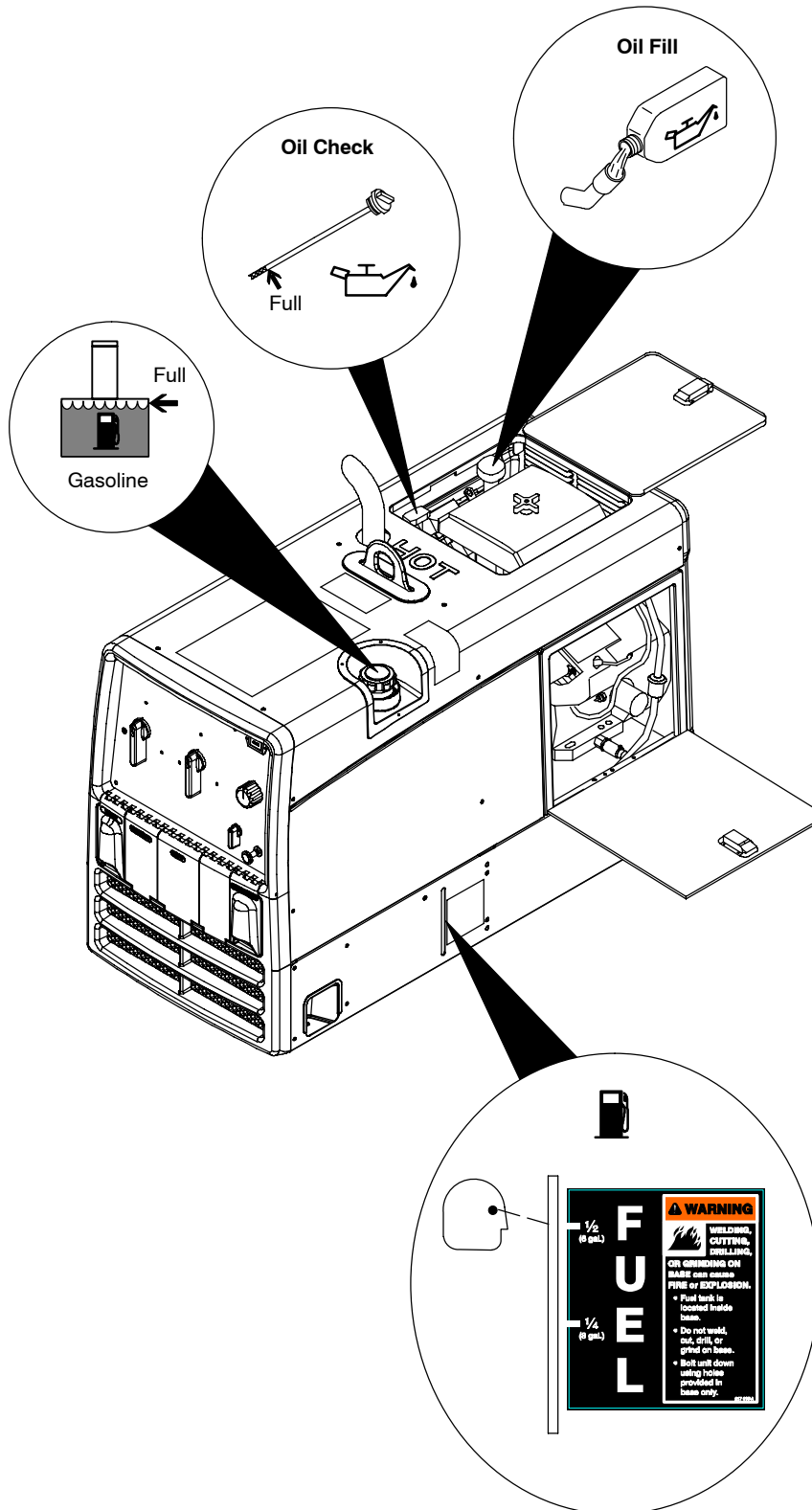

Check all fluids daily. Engine must be cold and on a level surface. Unit is shipped with 10W30 engine oil.

☞ Follow run-in procedure in engine manual.

☞ This unit has a low oil pressure shutdown switch. However, some conditions may cause engine damage before the engine shuts down. Check oil level often and do not use the oil pressure shutdown system to monitor oil level.

Open top service door.

Fuel

To help prime the fuel system at initial start-up, fill tank with fresh fuel (see maintenance label for specifications). Always leave filler neck empty to allow room for expansion. Check fuel level on a cold engine before use each day.

Oil

☞ Do not exceed the "Full" mark on the oil level dipstick. The fuel pump may operate erratically if crankcase is overfilled.

After fueling, check oil with unit on level surface. If oil is not up to full mark on dipstick, add oil (see maintenance label).

☞ To improve cold weather starting:

Keep battery in good condition. Store battery in warm area.

Use correct grade oil for cold weather.

Close top service door.

5-3. Engine Prestart Checks (Kohler-Powered Units)

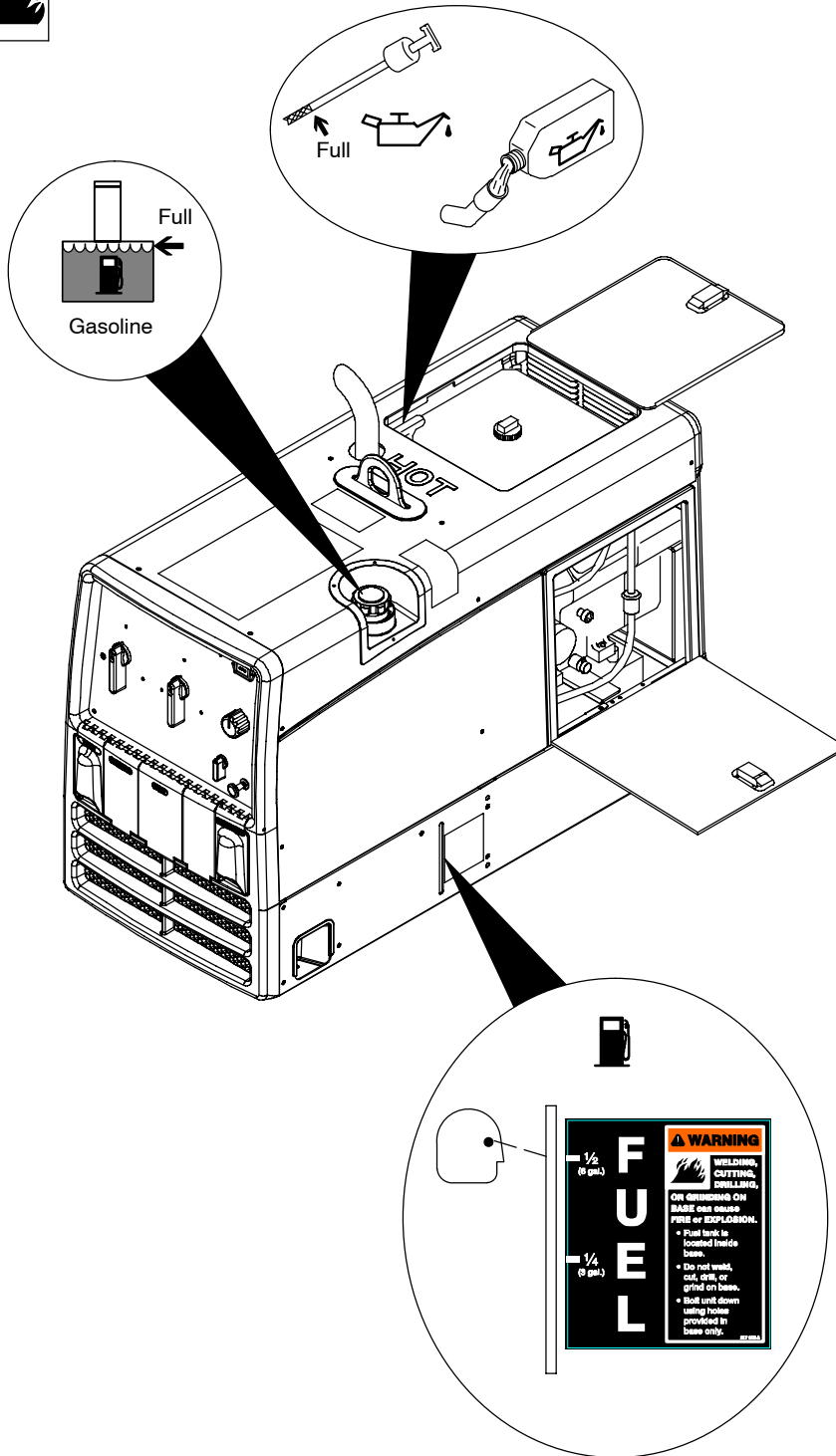

Check all fluids daily. Engine must be cold and on a level surface. Unit is shipped with 10W30 engine oil.

☞ Follow run-in procedure in engine manual.

☞ This unit has a low oil pressure shutdown switch. However, some conditions may cause engine damage before the engine shuts down. Check oil level often and do not use the oil pressure shutdown system to monitor oil level.

Open top service door.

Fuel

To help prime the fuel system at initial start-up, fill tank with fresh fuel (see maintenance label for specifications). Always leave filler neck empty to allow room for expansion. Check fuel level on a cold engine before use each day.

Oil

☞ Do not exceed the "Full" mark on the oil level dipstick. The fuel pump may operate erratically if crankcase is overfilled.

After fueling, check oil with unit on level surface. If oil is not up to full mark on dipstick, add oil (see maintenance label).

☞ To improve cold weather starting:

Keep battery in good condition. Store battery in warm area.

Use correct grade oil for cold weather.

Close top service door.

5-4. Activating The Dry Charge Battery (If Applicable)

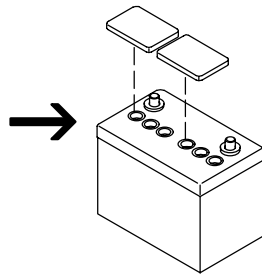
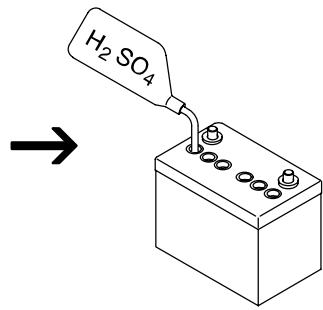
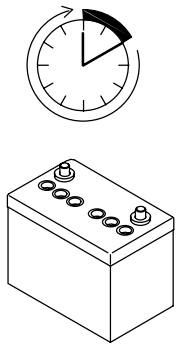
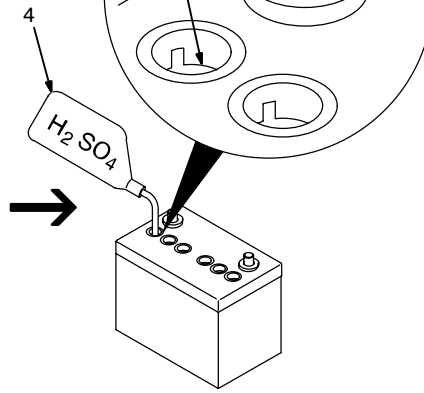
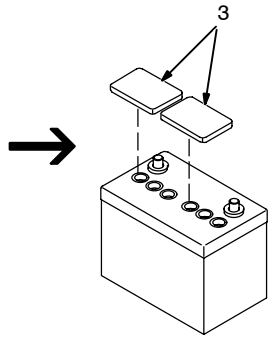
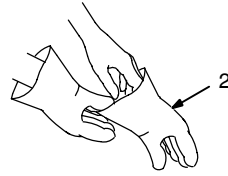
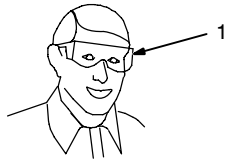
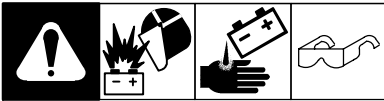

5 A For 30 Minutes

OR



30 A For 12 Minutes

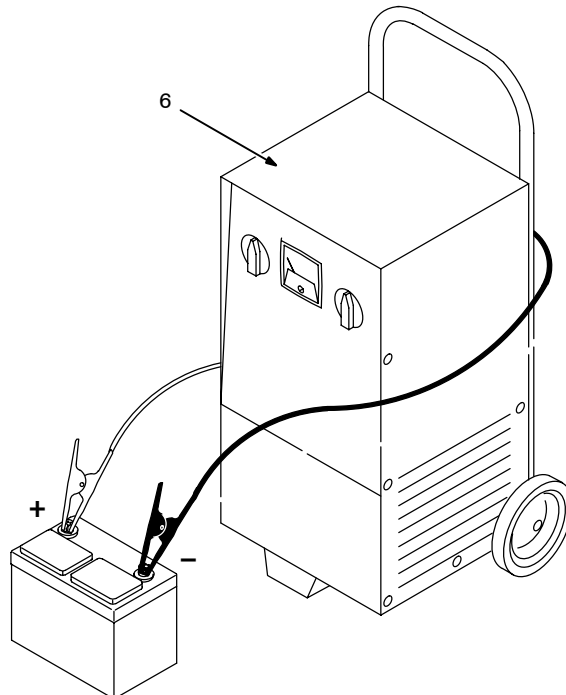

Remove battery from unit.

- 1 Eye Protection – Safety Glasses Or Face Shield
- 2 Rubber Gloves
- 3 Vent Caps
- 4 Sulfuric Acid Electrolyte (1.265 Specific Gravity)
- 5 Well

Fill each cell with electrolyte to **bottom** of well (maximum).

▲ **Do not overfill battery cells.**

Wait ten minutes and check electrolyte level. If necessary, add electrolyte to raise to proper level. Reinstall vent caps.

- 6 Battery Charger

▲ **Read and follow all instructions supplied with battery charger.**

Charge battery for 12 minutes at 30 amperes or 30 minutes at 5 amperes. Disconnect charging cables and install battery.

☞ *When electrolyte is low, add only distilled water to cells to maintain proper level.*

Tools Needed:

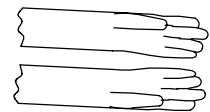
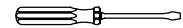

rubbergloves

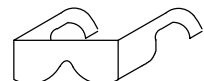

glasses

drybatt1 1/98 – S-0886

5-5. Connecting Or Replacing the Battery



Connecting The Battery

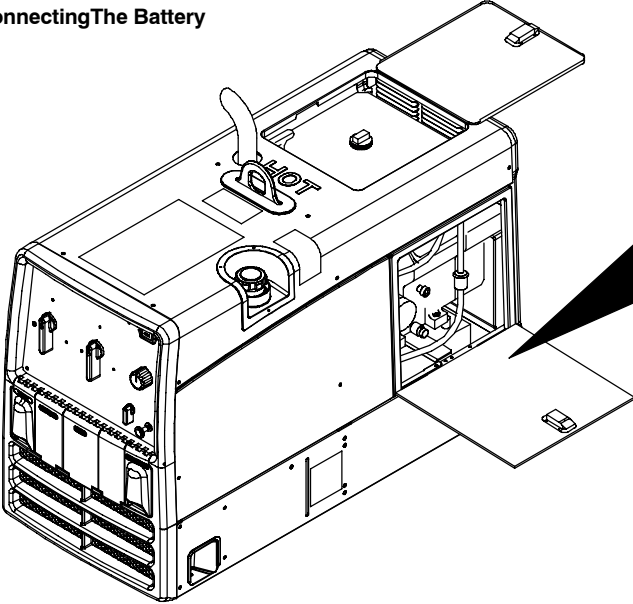

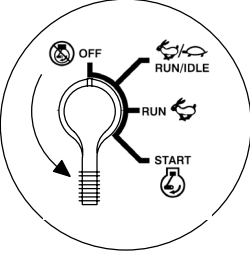

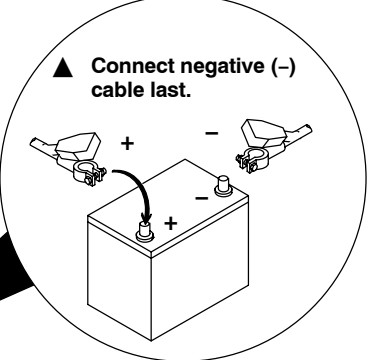

▲ Connect negative (-) cable last.

Replacing The Battery

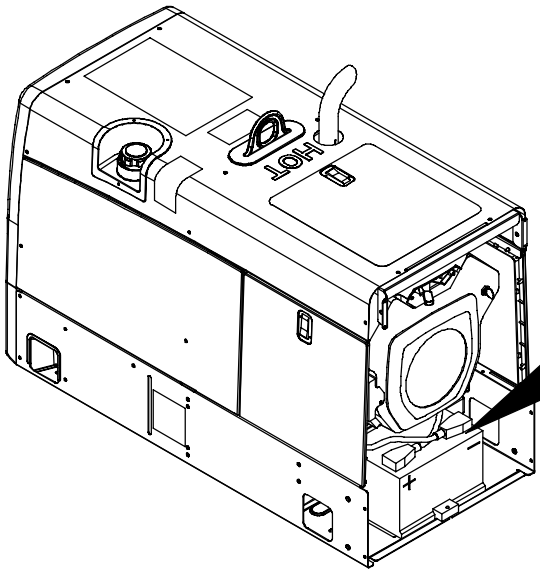

☞ Remove end panel to replace battery.

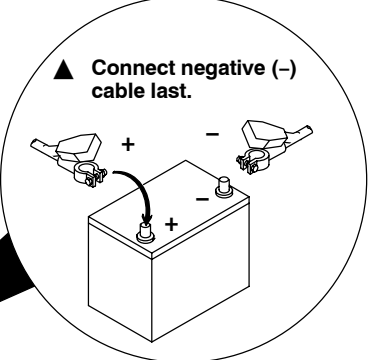

▲ Connect negative (-) cable last.

Tools Needed:

☞ 3/8, 1/2 in

803 754 / Ref. S-0756-D

5-6. Installing Exhaust Pipe



Installing Exhaust Pipe

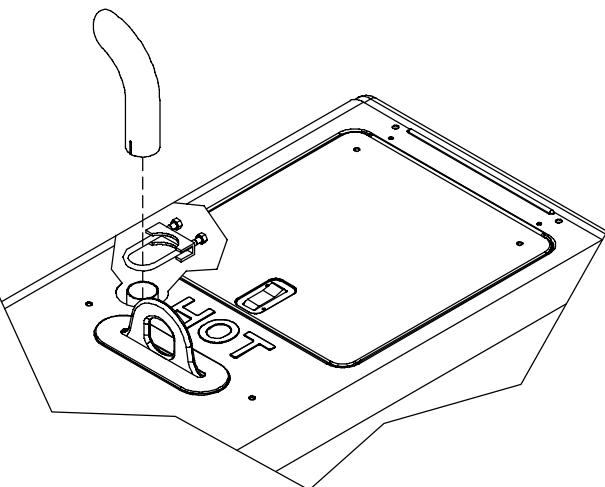

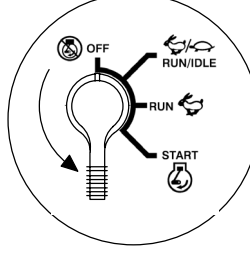

▲ Engine backfire can cause severe burns or other injuries. Do not point exhaust pipe toward control panel. Keep away from exhaust outlet.

☞ Point exhaust pipe in desired direction but always away from front panel and direction of travel.

☞ Be sure to tighten exhaust clamp nuts. Exhaust clamp supplied with muffler.

Tools Needed:

☞ 1/2 in

803 751 / Ref. 211 362-A-A

5-7. Connecting to Weld Output Terminals

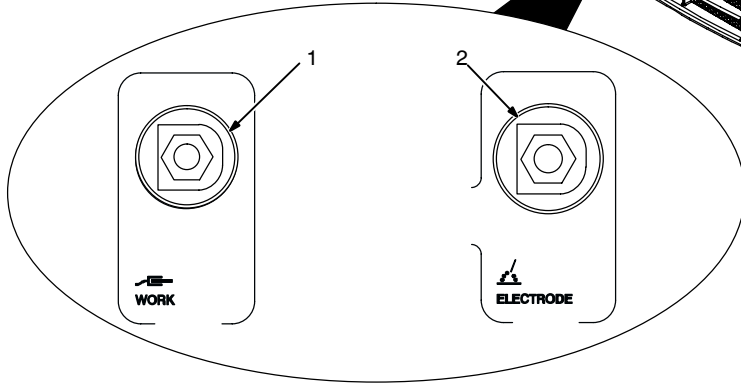
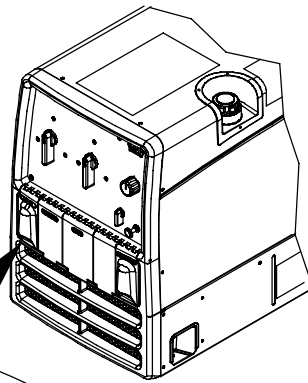

☞ See Section 6 for examples of typical weld connections and control settings.

- 1 Work Weld Output Terminal
- 2 Electrode Weld Output Terminal

Connect work cable to Work terminal. Connect electrode holder cable or electrode weld cable to Electrode terminal for Stick and MIG welding.

Connect torch cable to Electrode terminal for TIG welding.

Use Process Selector switch to select type of weld output (see Section 6-1).

☞ See Sections 6-2 thru 6-4 for typical process connections and control settings.

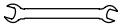
Tools Needed:
 3/4 in

803 750 / Ref. 211 362-A-A

5-8. Selecting Weld Cable Sizes*

 Weld Output Terminals ▲ Turn off power before connecting to weld output terminals. ▲ Do not use worn, damaged, undersized, or poorly spliced cables.	Welding Amperes	Weld Cable Size** and Total Cable (Copper) Length in Weld Circuit Not Exceeding***							
		100 ft (30 m) or Less		150 ft (45 m)	200 ft (60 m)	250 ft (70 m)	300 ft (90 m)	350 ft (105 m)	400 ft (120 m)
		10 – 60% Duty Cycle	60 – 100% Duty Cycle	10 – 100% Duty Cycle					
	100	4 (20)	4 (20)	4 (20)	3 (30)	2 (35)	1 (50)	1/0 (60)	1/0 (60)
	150	3 (30)	3 (30)	2 (35)	1 (50)	1/0 (60)	2/0 (70)	3/0 (95)	3/0 (95)
	200	3 (30)	2 (35)	1 (50)	1/0 (60)	2/0 (70)	3/0 (95)	4/0 (120)	4/0 (120)
	250	2 (35)	1 (50)	1/0 (60)	2/0 (70)	3/0 (95)	4/0 (120)	2 ea. 2/0 (2x70)	2 ea. 2/0 (2x70)
	300	1 (50)	1/0 (60)	2/0 (70)	3/0 (95)	4/0 (120)	2 ea. 2/0 (2x70)	2 ea. 3/0 (2x95)	2 ea. 3/0 (2x95)
	350	1/0 (60)	2/0 (70)	3/0 (95)	4/0 (120)	2 ea. 2/0 (2x70)	2 ea. 3/0 (2x95)	2 ea. 3/0 (2x95)	2 ea. 4/0 (2x120)
	400	1/0 (60)	2/0 (70)	3/0 (95)	4/0 (120)	2 ea. 2/0 (2x70)	2 ea. 3/0 (2x95)	2 ea. 4/0 (2x120)	2 ea. 4/0 (2x120)
	500	2/0 (70)	3/0 (95)	4/0 (120)	2 ea. 2/0 (2x70)	2 ea. 3/0 (2x95)	2 ea. 4/0 (2x120)	3 ea. 3/0 (3x95)	3 ea. 3/0 (3x95)

* This chart is a general guideline and may not suit all applications. If cables overheat, use next size larger cable.

**Weld cable size (AWG) is based on either a 4 volts or less drop or a current density of at least 300 circular mils per ampere. () = mm² for metric use

S-0007-F

***For distances longer than those shown in this guide, call a factory applications representative at 920-735-4505.

SECTION 6 – OPERATING THE WELDING GENERATOR

6-1. Front Panel Controls

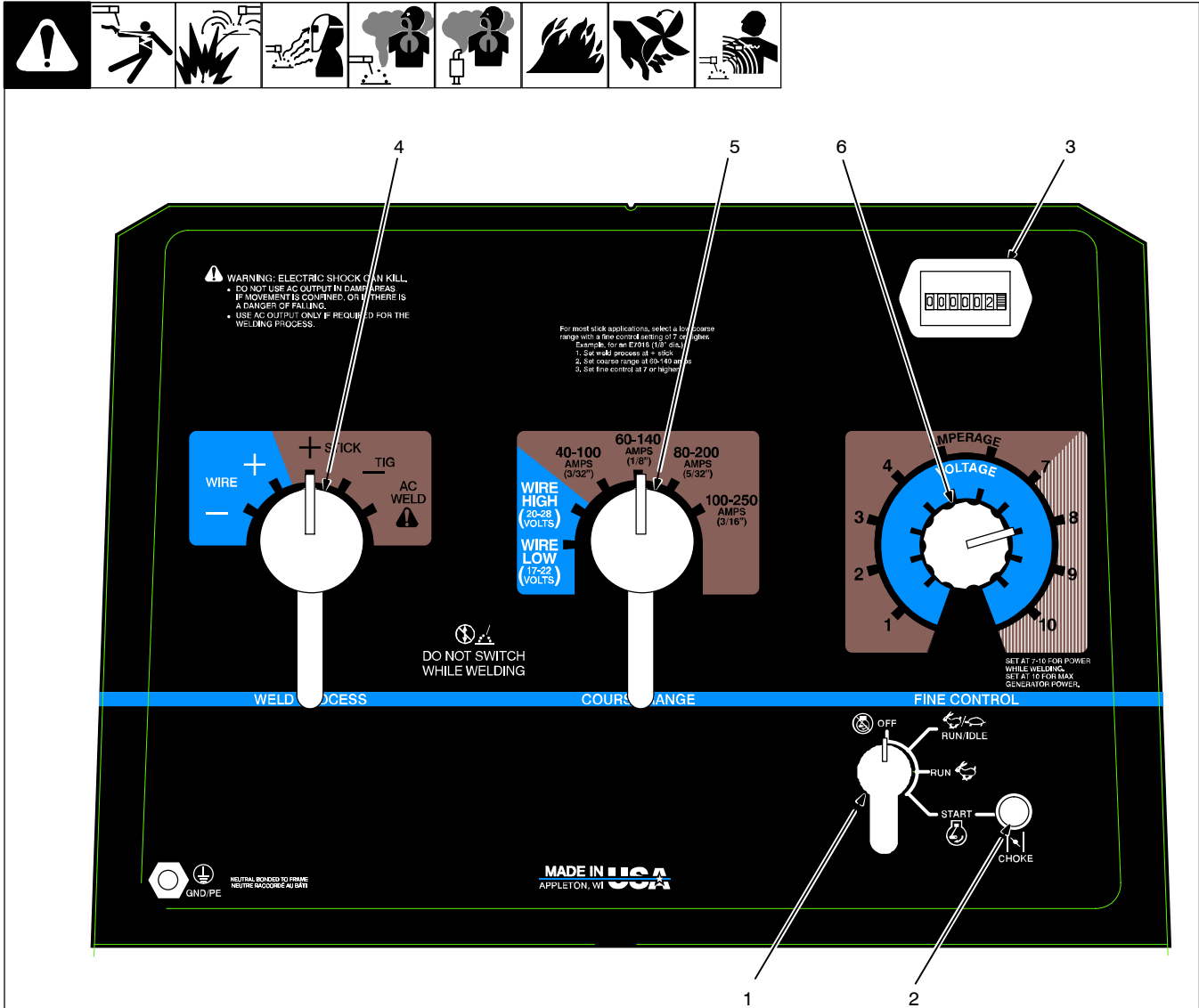

Ref. 211 362-A

1 Engine Control Switch

Use switch to start engine, select speed, and stop engine. In Run/Idle position, engine runs at idle speed at no load, and weld/power speed under load. In Run position, engine runs at weld/power speed.

☞ Place switch in Run position to operate most MIG equipment.

2 Engine Choke Control

Use control to change engine air-fuel mix.

To Start: pull out choke and turn Engine Control switch to Start position. Release switch and slowly push choke in when engine starts.

☞ If the engine does not start, let engine come to a complete stop before attempting restart.

To Stop: turn Engine Control switch to Off position.

3 Engine Hour Meter

4 Weld Process Selector Switch

▲ **Do not switch under load.**

Use switch to select type of weld output.

Wire (GMAW) Welding: Use a positive (+) position for Direct Current Electrode Positive (DCEP) and a negative (-) position for Direct Current Electrode Negative.

Stick (SMAW) and TIG (GTAW Welding): Use a positive (+) position for Direct Current Electrode Positive (DCEP) and a negative (-) position for Direct Current Electrode Negative. Use AC position for alternating current.

5 Coarse Range Switch

▲ **Do not switch under load.**

Use switch to select weld amperage range when Weld Process Selector switch is in Stick/

Tig position, or voltage range when switch is in Wire position.

☞ For best arc starts and when using weld and generator power together, use a low Coarse Range setting with the Fine control set at 7 or higher.

6 Fine Control

Use control to select weld amperage (Stick/Tig) or voltage (Wire) within the range selected by the Coarse Range switch. Control may be adjusted while welding.

Set control at 10 for maximum generator power.

Weld output would be about 124 A DC based on control settings shown (80% of 60 to 140 A). Settings shown are typical for welding with a 7018 (1/8) electrode.

☞ See Sections 6-2 thru 6-4 for typical process connections and control settings.

6-2. Typical Stick Welding Connections And Control Settings

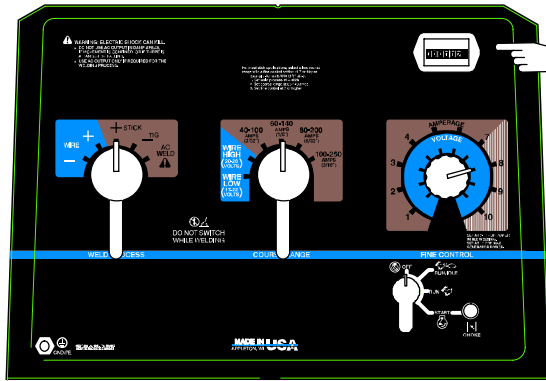

For best arc starts and best results using weld and generator power together, use a low Coarse Range setting and the Fine control set at 7 or higher.

Typical Settings For 7018 (1/8 in) Electrode

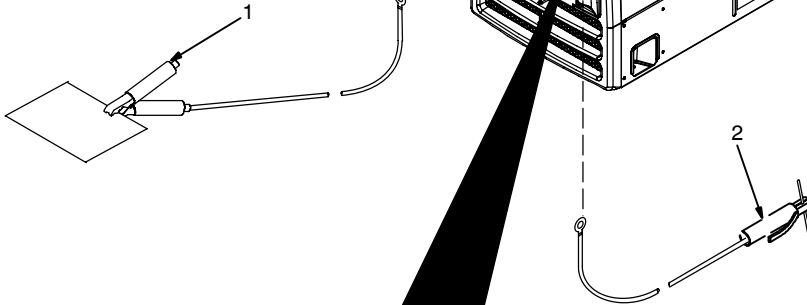

▲ Stop engine.

This section provides general guidelines and may not suit all applications.

The control panel shows the typical settings for welding with a 7018 (1/8 in) electrode. Consult the amperage selection tables below if welding with other electrodes.

- 1 Work Clamp
- 2 Electrode Holder

Connect Work cable to Work terminal and Electrode holder cable to Electrode terminal on welding generator.

Be sure to use the correct size weld cables (see Section 5-8).

For best performance, set the Coarse Range switch to the **lowest** range that covers the desired weld amperage. Use the Fine control to select the desired amperage within the range selected. When properly set, the Fine control is normally set at 7 or higher.

Typical Settings For 7018 (1/8 in) Electrode:

- > Set Weld Process Selector switch to + Stick position.
- > Set Coarse Range switch to 60-140 (1/8") position.
- > Set Fine control at 7 or higher for best results.

Electrode Selection Table (Beneath Cover)

ELECTRODE	DIAMETER	AMPERAGE RANGE								
		50	100	150	200	250	300	350	400	450
6010 & 6011	3/32									
	1/8									
	5/32									
	3/16									
	7/32									
6013	1/4									
	5/64									
	3/32									
	1/8									
	5/32									
7014	3/16									
	7/32									
	1/4									
	3/32									
	1/8									
7018	5/32									
	3/16									
	7/32									
	1/4									
	3/32									
7024	1/8									
	5/32									
	3/16									
	7/32									
	1/4									
Ni-Cl	3/32									
	1/8									
	5/32									
308L	3/16									
	1/8									
	5/32									

ELECTRODE	DC*	AC	POSITION	PENETRATION	USAGE
6010	EP		ALL	DEEP	MIN. PREP, ROUGH HIGH SPATTER
6011	EP	✓	ALL	DEEP	
6013	EP,EN	✓	ALL	LOW	GENERAL
7014	EP,EN	✓	ALL	MED	SMOOTH, EASY, FAST
7018	EP	✓	ALL	LOW	LOW HYDROGEN, STRONG
7024	EP,EN	✓	FLAT HORIZ FILLET	LOW	SMOOTH, EASY, FASTER
NI-CL	EP	✓	ALL	LOW	CAST IRON
308L	EP	✓	ALL	LOW	STAINLESS

*EP = ELECTRODE POSITIVE (REVERSE POLARITY)
EN = ELECTRODE NEGATIVE (STRAIGHT POLARITY)

Tools Needed:

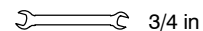

6-3. Typical MIG Welding Connections And Settings

A. Solid Wire Applications



Typical Control Settings For .035 (ER70S-3) Solid Wire – Short Circuit Transfer

Note Coarse Range, Fine Control, and Weld Process switch settings.

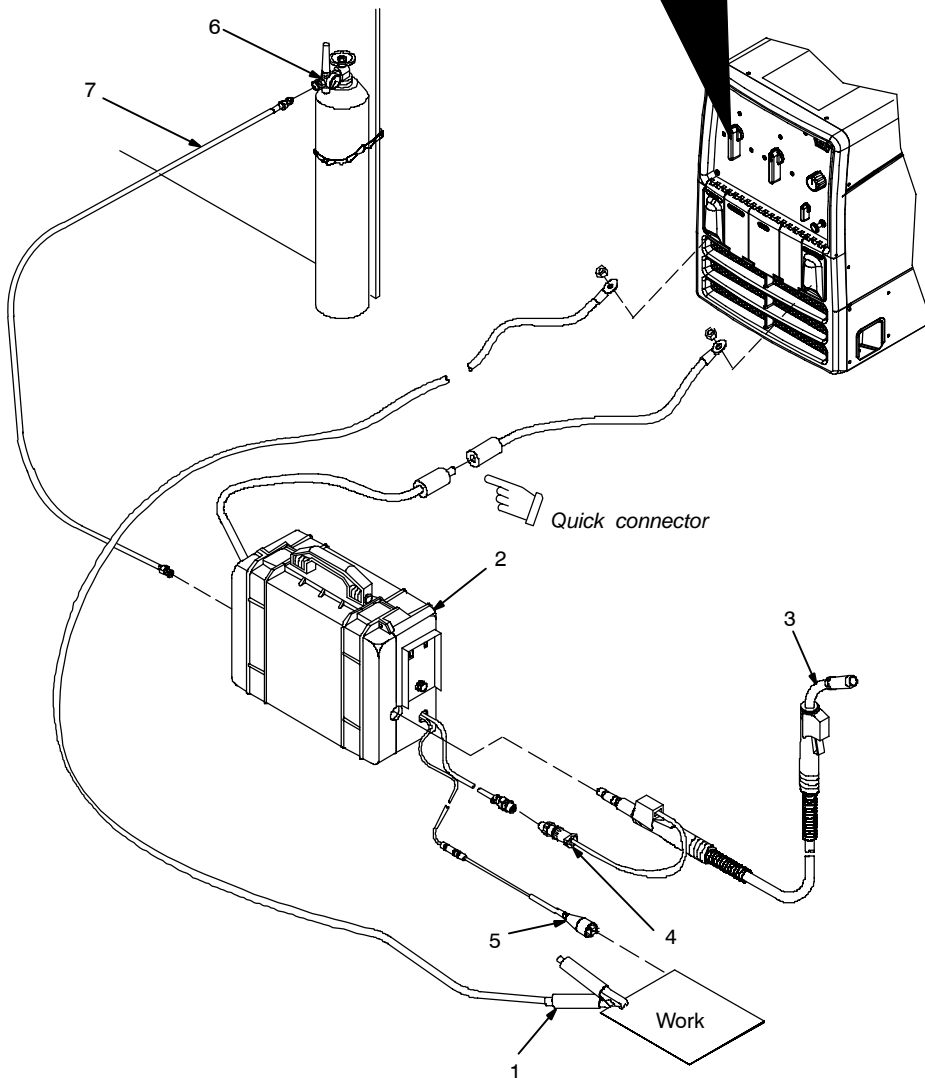
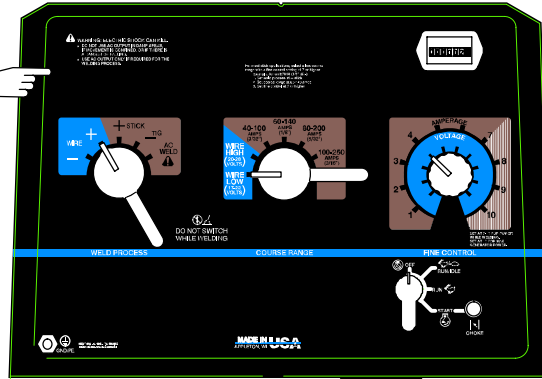

Tools Needed:
 3/4 in

▲ Stop engine.

This section provides general guidelines and may not suit all applications.

The control panel shows the typical settings for welding with .035 (ER70S-3) solid wire. Use Argon-based shielding gas.

- 1 Work Clamp
- 2 Wire Feeder
- 3 MIG Gun
- 4 Gun Trigger Plug
- 5 Voltage Sensing Clamp
- 6 Gas Cylinder:

75/25 Argon-Based Gas for Short Circuit Transfer

80% Argon (Or Higher) For Spray Transfer

- 7 Gas Hose

Connect work cable to welding generator Work terminal. Connect cable from wire feeder to cable from welding generator Electrode terminal.

Be sure to use the correct size weld cables (see Section 5-8).

Loosen MIG gun securing knob. Insert gun end through opening in feeder and position as close as possible to drive rolls without touching. Tighten knob.

See wire feeder manual for wire threading procedure.

Insert gun trigger plug (item 4) into matching receptacle and tighten threaded collar.

Connect gas hose from feeder to regulator on cylinder.

Typical Control Settings For Short Circuit Transfer Using .035 (ER70S-3) Solid Wire And 75/25 Argon-Based Gas:

- > Set Weld Process Selector switch to Wire + (DCEP) position.
- > Set Coarse Range switch to Wire/Low Range (17-22 volts) position.
- > Set Fine Control to obtain minimum spatter.
- > Set wire feed speed between 150-300 ipm.

Typical Control Settings For Spray Transfer Using .035 (ER70S-3) Solid Wire And 80% Or Higher Argon-Based Gas:

- > Set Weld Process Selector switch to Wire + position.
- > Set Coarse Range switch to Wire/High Range (20-28 volts) position.
- > Set wire feed speed between 320-500 ipm.
- > Set Fine control to 3 and increase for longer arc length.

B. Self-Shielded Flux Core Wire Applications



Typical Control Settings For .045 (71T-11) Self-Shielded Flux Core Wire

Note Coarse Range, Fine Control, and Weld Process switch settings.

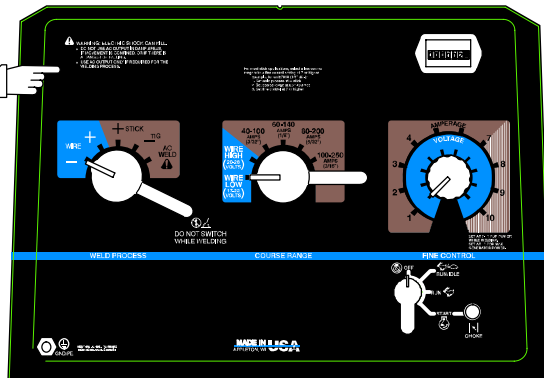

▲ Stop engine.

This section provides general guidelines and may not suit all applications.

The control panel shows the typical settings for welding with .045 (71T-11) self-shielded flux core wire.

- 1 Work Clamp
- 2 Wire Feeder
- 3 MIG Gun
- 4 Gun Trigger Plug
- 5 Voltage Sensing Clamp

Connect work cable to welding generator Work terminal. Connect cable from wire feeder to cable from welding generator Electrode terminal.

Be sure to use the correct size weld cables (see Section 5-8).

Loosen MIG gun securing knob. Insert gun end through opening in feeder and position as close as possible to drive rolls without touching. Tighten knob.

See wire feeder manual for wire threading procedure.

Insert gun trigger plug (item 4) into matching receptacle and tighten threaded collar.

Typical Control Settings Using .045 (71T-11) Self-Shielded Flux Core Wire :

- > Set Weld Process Selector switch to Wire – position (DCEN).
- > Set Coarse Range switch to Wire/Low Range (17-22 volts) position.
- > Set Fine Control near minimum setting.
- > Set wire feed speed between 125-200 ipm.
- > Do a test weld. To increase arc length, increase Fine Control setting. To shorten arc length, reduce fine control setting or increase wire feed speed.

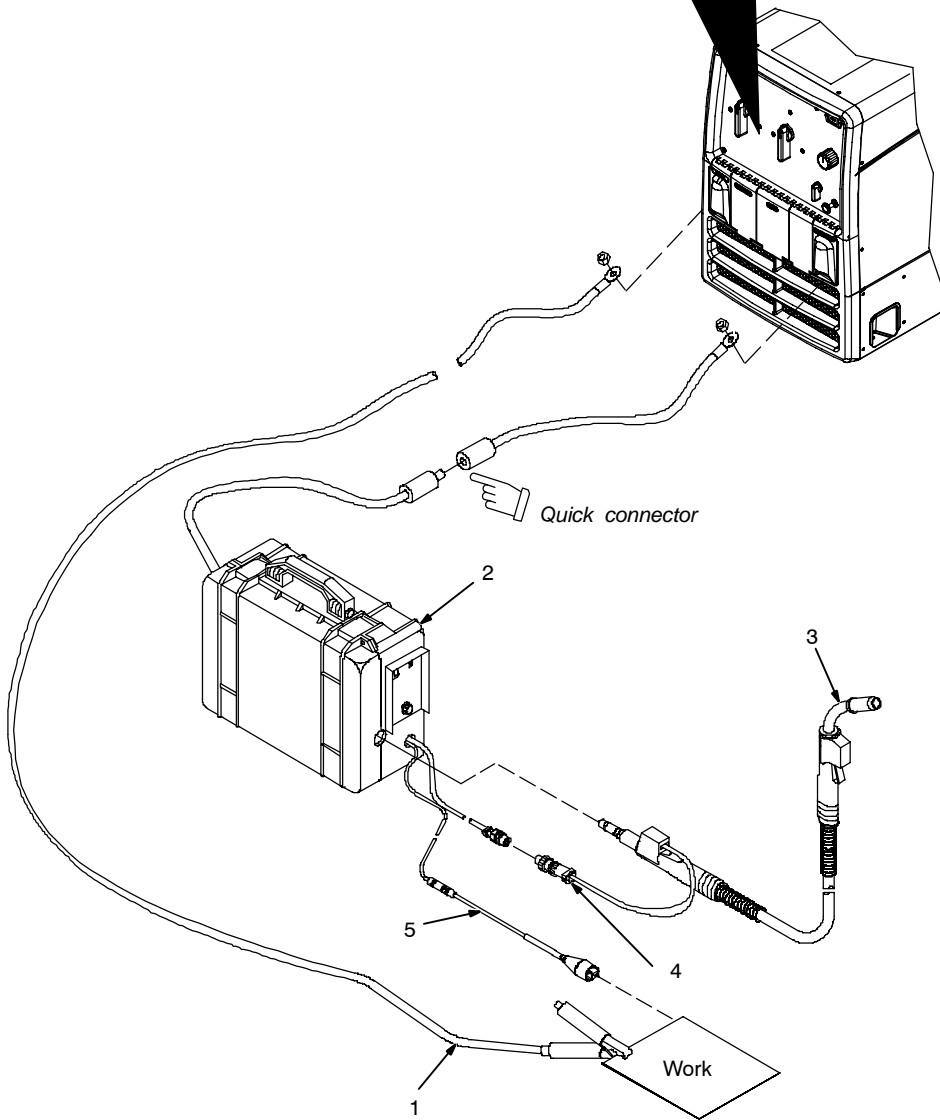

Tools Needed:

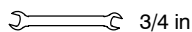

6-4. Typical MIG Connections And Settings Using Weld Control And Spoolgun



Tools Needed:

3/4 in

Typical Settings For 4043 (.035) Aluminum On 1/8 in Material:

Note Coarse Range and Weld Process switch settings.

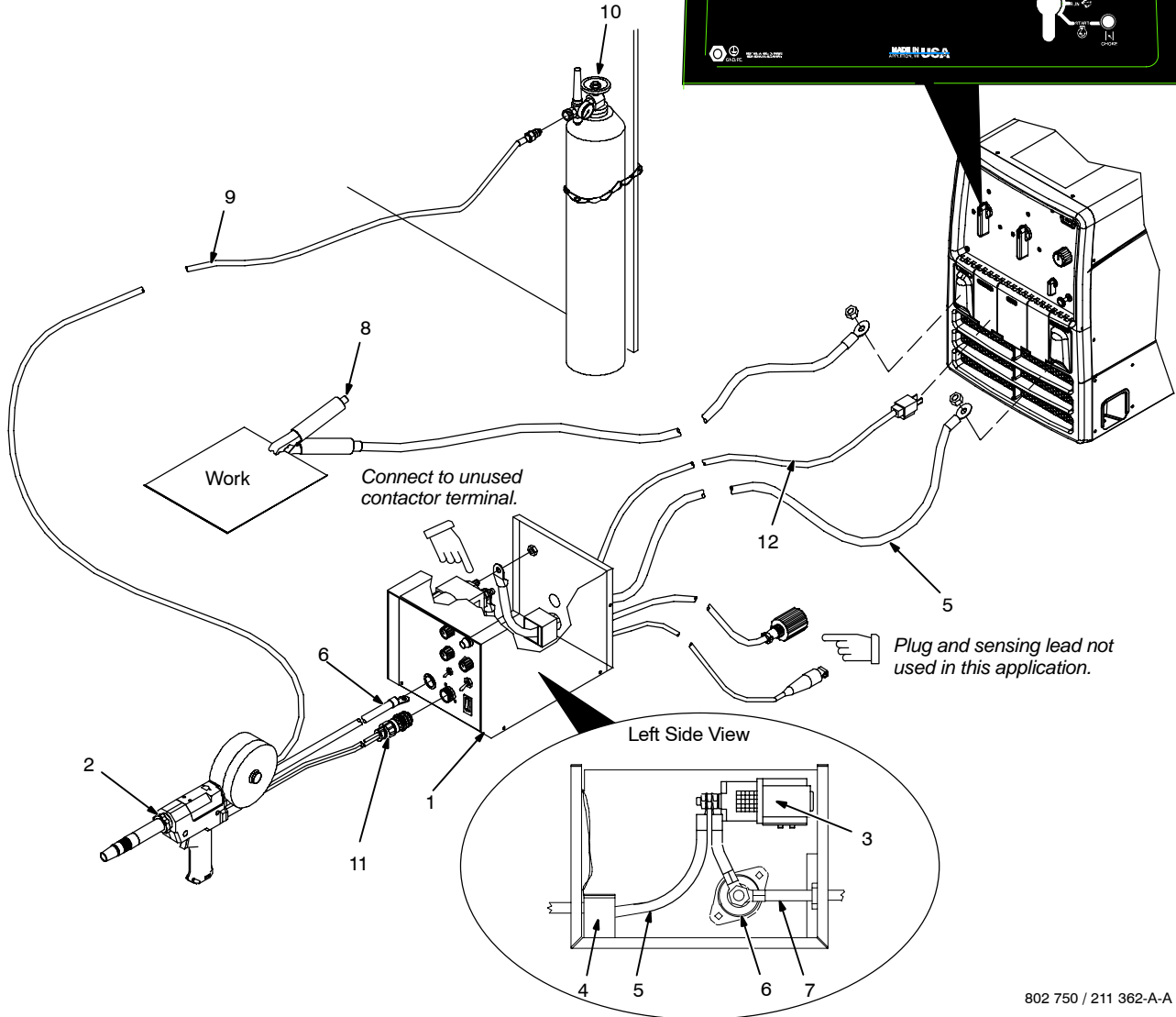
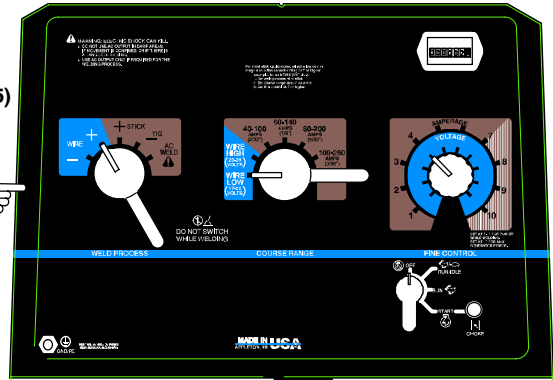

802 750 / 211 362-A-A

This section provides general guidelines and may not suit all applications.

- 1 Weld Control
- 2 Spoolgun
- 3 Optional Contactor (Recommended)
- 4 Reed Switch
- 5 Weld Cable (Customer-Supplied)
- 6 Weld Control Weld Terminal
- 7 Weld Power Cable From Spoolgun
- 8 Work Clamp
- 9 Gas Hose
- 10 Argon Cylinder
- 11 Trigger Control Cord
- 12 Input Power Cord

Be sure to use the correct size weld cables (see Section 5-8).

- Route weld cable from welding generator Electrode terminal through reed switch to unused contactor terminal. Connect weld cable from spoolgun to weld control weld terminal (item 6).
- Connect work cable to welding generator Work terminal.
- Insert trigger control plug (item 11) into weld control receptacle. Tighten threaded collar.
- Connect ac power cord (item 12) to 120 volt ac receptacle on welding generator.
- Connect gas hose from spoolgun to regulator on Argon bottle.
- Reinstall weld control wrapper.

Typical Settings For 4043 (.035) Aluminum On 1/8 in Material:

- > Set Weld Process Selector switch to Wire + (DCEP) position.
- > Set Coarse Range switch to Wire/Low (17-22 volts) position.
- > Set Fine Control to desired voltage (arc length). Start with a low voltage setting (about 4) to prevent burnback.
- > Set wire feed speed between 240-270 ipm. For 1/4 in. and thicker materials, set Coarse Range switch to Wire/High and Fine Control to 6. Increase/decrease Fine Control setting to increase/decrease arc length.

SECTION 7 – OPERATING AUXILIARY EQUIPMENT

7-1. Standard Receptacles

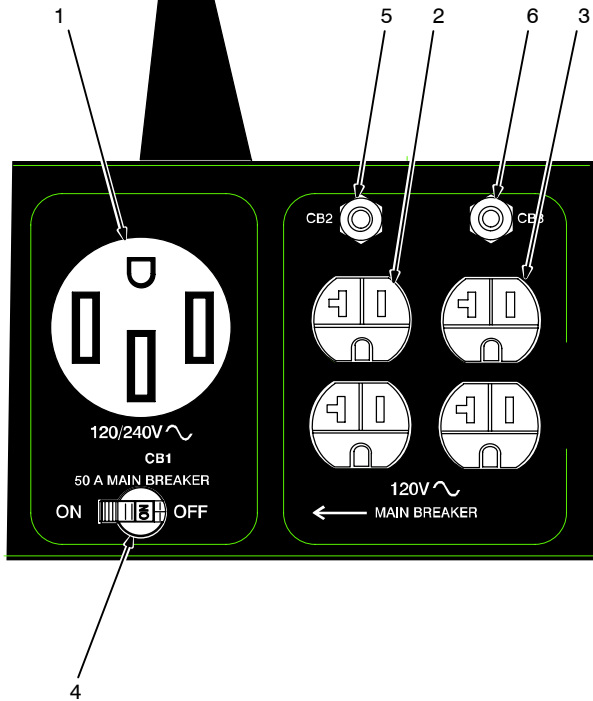
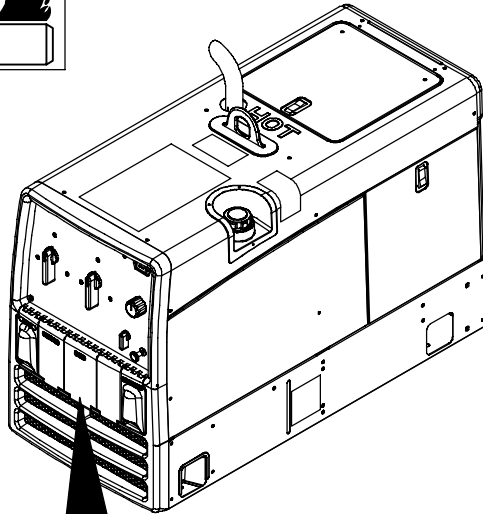

▲ If unit does not have GFCI receptacles, use GFCI-protected extension cord.

☞ Generator power decreases as weld current increases.

Set Fine Control R1 at 10 for full generator power.

- 1 240 V 50 A AC Receptacle RC1
RC1 supplies 60 Hz single-phase power at weld/power speed. Maximum output is 10 kVA/kW.
- 2 120 V 20 A AC Duplex Receptacle RC2
- 3 120 V 20 A AC Duplex Receptacle RC3

RC2 and RC3 supply 60 Hz single-phase power at weld/power speed. Maximum output from RC2 or RC3 is 2.4 kVA/kW.

4 Circuit Breaker CB1
CB1 protects receptacles RC1, RC2, and RC3 from overload. If CB1 opens, the receptacles do not work. Place switch in On position to reset breaker.

- 5 Circuit Breaker CB2
- 6 Circuit Breaker CB3

CB2 protects RC2 and CB3 protects RC3 from overload. If a circuit breaker opens, the receptacle does not work.

☞ Press button to reset circuit breaker. If breaker continues to open, contact Factory Authorized Service Agent.

Combined output of all receptacles limited to 10 kVA/kW rating of the generator.

EXAMPLE: If 20 A is drawn from each 120 V duplex receptacle, only 21 A is available at the 240V receptacle:

$$2 \times (120 \text{ V} \times 20 \text{ A}) + (240 \text{ V} \times 21 \text{ A}) = 10 \text{ kVA/kW}$$

7-2. Optional Generator Power Receptacles

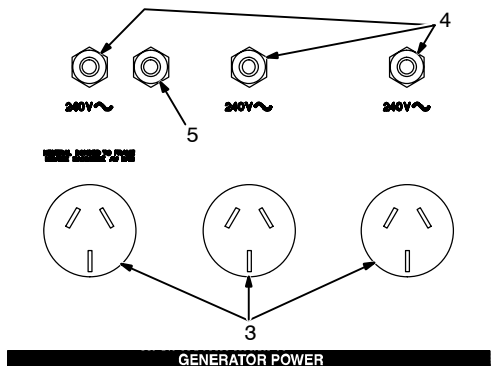
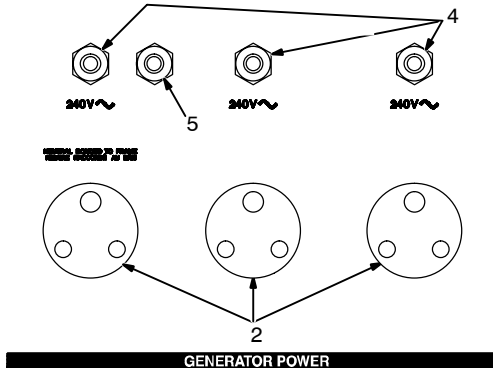
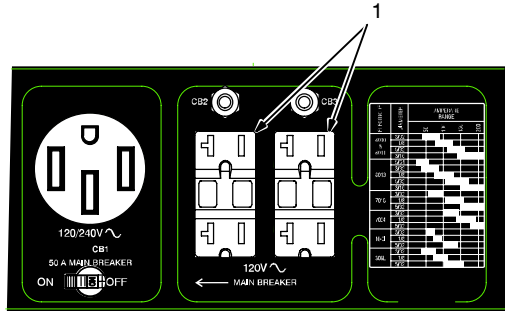

▲ If unit does not have GFCI receptacles, use GFCI-protected extension cord.

☞ Generator power decreases as weld current increases.

Set Fine Control R1 at 10 for full generator power.

Combined output of all receptacles limited to 10 kVA/kW rating of the generator.

CSA/GFCI Receptacle Option

- 1 120 V 20 A AC GFCI Receptacles GFCI-2 and GFCI-3

GFCI2 and GFCI3 supply 60 Hz single-phase power at weld/power speed. Maximum output from GFCI-2 or GFCI-3 is 2.4 kVA/kW. Circuit breaker protection is the same as standard receptacles.

If a ground fault is detected, the GFCI Reset button pops out and the circuit opens to disconnect the faulty equipment. Check for damaged tools, cords, plugs, etc. connected to the receptacle. Press button to reset receptacle and resume operation.

▲ Power is still present at the 240 V receptacle when only one circuit breaker trips.

Unplug power cord before attempting to service accessories or tools.

☞ At least once a month, run engine at weld/power speed and press Test button to verify GFCI is working properly.

South African And Australian Receptacle Options

- 2 240 V 16 A AC South African Receptacles RC1, RC2, and RC3
- 3 240 V 15 A AC Australian Receptacles RC1, RC2, and RC3

Receptacles supply 60 Hz single-phase power at weld/power speed. Maximum output from each receptacle is 3.6 kVA/kW.

- 4 Circuit Breakers CB1, CB2, CB3

CB1, CB2, and CB3 protect RC1, RC2, and RC3 from overload. If a circuit breaker opens, the receptacle does not work.

- 5 Circuit Breaker CB4

CB4 protects all the receptacles from overload. If CB4 opens, none of the receptacles work.

☞ Press button to reset circuit breaker. If breaker continues to open, contact Factory Authorized Service Agent.

7-3. Wiring Optional 240 Volt Plug



Current Available in Amperes	
240 V Receptacle*	Each 120 V Duplex Receptacle
0	20
5	20
10	20
15	20
20	20
25	15
30	10
35	5
40	0

V x A = Watts

*One 240 V load or two 120 V loads.

The plug can be wired for a 240 V, 2-wire load or a 120/240V, 3-wire load. See circuit diagram.

1 Plug Wired for 120/240 V, 3-Wire Load

When wired for 120 V loads, each duplex receptacle shares a load with one half of 240 V receptacle.

2 Plug Wired for 240 V, 2-Wire Load

3 Neutral (Silver) Terminal

4 Load 1 (Brass) Terminal

5 Load 2 (Brass) Terminal

6 Ground (Green) Terminal

7 Amperes Available using 120/240 V Plug

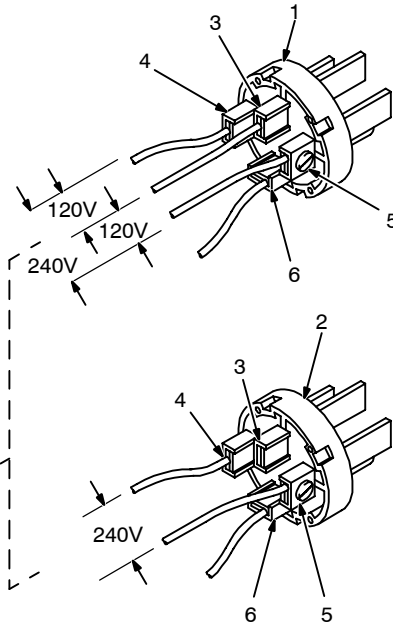



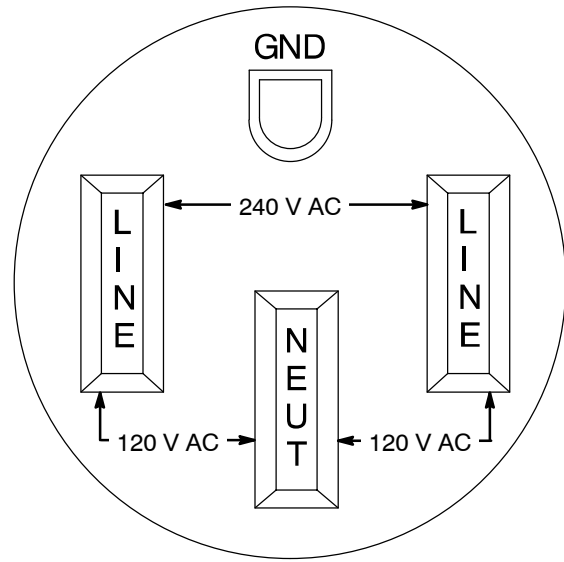
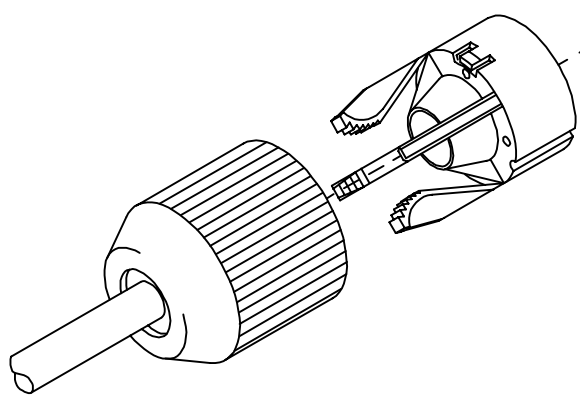
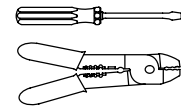





















Tools Needed:

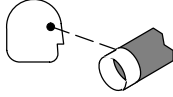

SECTION 8 – MAINTENANCE (Robin-POWERED UNITS)

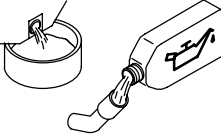
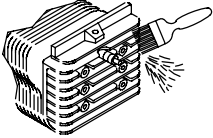
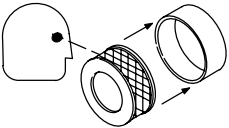
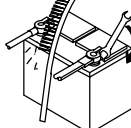
8-1. Routine Maintenance (Robin-Powered Units)

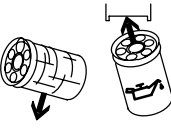
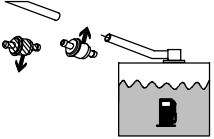
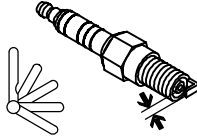
Note  Follow the storage procedure in the engine owner's manual if the unit will not be used for an extended period.

      		 <p>Recycle engine fluids.</p>	<p>▲ Stop engine before maintaining.</p> <p> See Engine Manual and Maintenance Label for important start-up, service, and storage information. Service engine more often if used in severe conditions.</p> <p>* To be done by Factory Authorized Service Agent.</p>
 Every 8 h			
<p>Check fluid levels. See Section 5-2.</p>	 	<p>Wipe up spills.</p>	
 Every 20 h		 Every 25 h	
<p>Check and clean spark arrestor screen. See Section 5-2.</p>		<p>Service air cleaner wrapper (foam element). See Section 8-3.</p>	
 Every 50 h			
<p>Clean and tighten weld terminals.</p>			
 Every 100 h			
<p>Change oil. See Section 8-5 and maintenance label.</p>		<p>Clean cooling system. See Engine Manual.</p>	
<p>Service air cleaner element. See Section 8-3.</p>		<p>Clean and tighten battery connections.</p>	
 Every 200 h			
<p>Change oil filter. See Section 8-5 and maintenance label.</p>		<p>Replace fuel filter. See Section 8-5.</p>	
<p>Check spark plugs.</p>			
<p>Replace unreadable labels.</p>			

 **Every 500 h**

Repair or replace cracked cables.

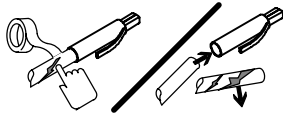

Service welding generator brushes and slip rings. Service more often in dirty conditions.*

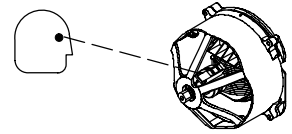

Check valve clearance.*

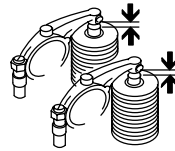

 **Every 1000 h**

Blow out or vacuum inside. During heavy service, clean monthly.

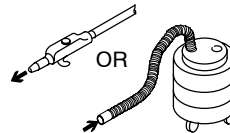

8-2. Maintenance Label (Robin-Powered Units)

KOHLER CH20, ROBIN EH64/EH65 GAS ENGINES

 See Engine Manual for complete engine care. Give Engine Specification and Serial Number when ordering parts.

 **Check Daily.**

Recommended Oil
API Service Classification . . . SG or higher
(If using LP fuel, use synthetic oil.)

Oil Change 100 hours
Oil Filter Change 200 hours
Oil Filter **KOHLER:** MILLER 066 698, Kohler 1205001
ROBIN: MILLER 198 754, Robin 248-65801-00

Oil Capacity w/filter change . . Approximately 1.5 quarts

DO NOT OVERFILL . . **KOHLER:** Keep oil level between L & F marks on dipstick.
ROBIN: Keep oil level between 2 holes on dipstick.

To Drain Oil:
Push And Turn CCW

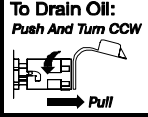



		KOHLER	ROBIN
°C	+38	↑ 10W-30	↑ 30
	+27		
°F	+80	↓ 5W-20, 5W-30	↓ 10W-30, 10W-40
	+50		
	0		
	+32		
	-18		
	-29		

 **Fuel Grade** Unleaded, 87 Octane min.
Fuel Filter **KOHLER:** MILLER 215 984, Kohler 2505008
ROBIN: MILLER 215 984, Robin 263-65012-A3

 **Air Filter Service** 100 hours – see Owner's Manual
Air Filter **KOHLER:** MILLER 067 272, Kohler 4708303
Air Filter Wrapper **KOHLER:** MILLER 067 273, Kohler 2408302
Air Filter **ROBIN:** MILLER 198 755, Robin 263-32610-A1
(Includes Air Filter Wrapper)

 **12 Volt Battery** BCI Group 58
Cranking Performance at 0°F (-18°C) . . . 430 Amps min.

 **Engine Speed**
No Load
High Speed . . . 3675-3750 RPM
Idle 2200-2300 RPM
Miller Legend . . See Owner's Manual

 **Spark Plug** **KOHLER:** MILLER 067 007, Kohler 1213202,
Champion RC-12YC
ROBIN: MILLER 198 777, Robin X65-01407-30,
NGK BPR4EY
Use only resistor spark plugs and wires.

Tune-up and Filter Kit . . (Includes Air, Oil and Fuel Filters, and 2 Spark Plugs)
KOHLER: MILLER 180 096
ROBIN: MILLER 199 062

215 938-C

8-3. Servicing Air Cleaner (Robin-Powered Units)

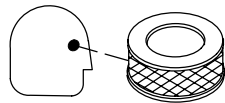
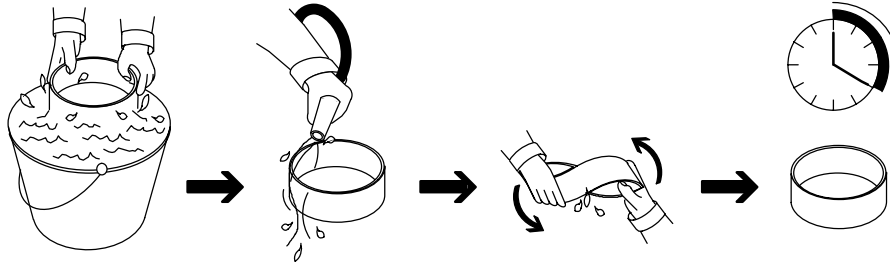
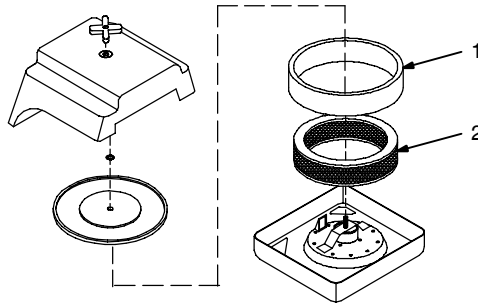
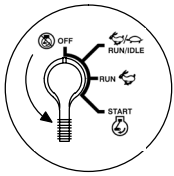

- ▲ **Stop engine.**
- ▲ **Do not run engine without air cleaner or with dirty element.**

- 1 Wrapper (Foam Element)
Wash wrapper with soap and water solution. Allow wrapper to air dry completely.
Spread 1 tablespoon SAE 30 oil evenly into wrapper. Squeeze out excess oil.
- 2 Element
Replace element if dirty, oily, or damaged.

aircleaner5 1/97 - 803 070 / Ref. 211 362-A-A / S-0759

8-4. Overload Protection (Robin-Powered Units)

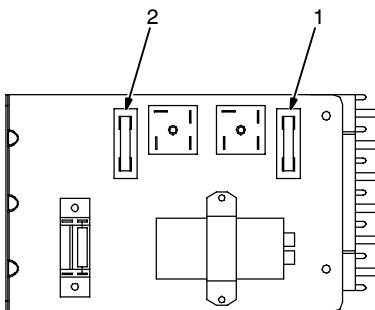
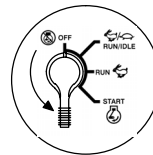

☞ Fuses located on bracket behind left side panel.

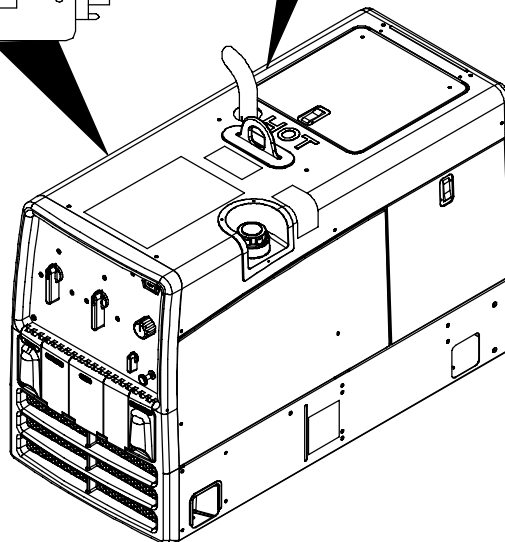
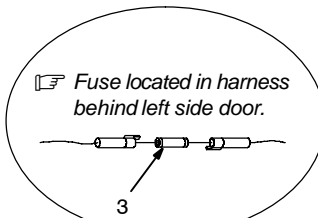

- ▲ **Stop engine. Disconnect negative (-) battery cable.**

- 1 Fuse F1 (See Parts List)
F1 protects the weld excitation winding from overload. If F1 opens, weld output stops or is low.
- 2 Fuse F2 (See Parts List)
F2 protects the generator power excitation winding from overload. If F2 opens, generator power output stops or is low.
- 3 Fuse F6 (See Parts List)
F6 protects the engine wiring system from overload. If F6 opens, engine will not crank.

Replace any open fuses. Reinstall cover before operating.

☞ *If a fuse opens, it usually indicates a more serious problem exists. Contact a Factory Authorized Service Agent.*

Tools Needed:

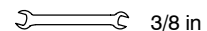
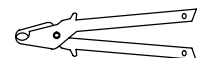

803 753

8-5. Changing Engine Oil, Oil Filter, and Fuel Filter (Robin-Powered Units)

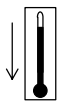
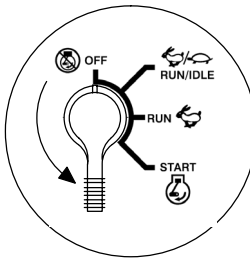

▲ Stop engine and let cool.

- 1 Oil Drain Valve
- 2 1/2 ID x 12 in Hose
- 3 Oil Filter

Change engine oil and filter according to engine owner's manual.

▲ Close valve and valve cap before adding oil and running engine.

Fill crankcase with new oil to full mark on dipstick (see Section 8-2).

- 4 Fuel Filter
- 5 Fuel Line

Replace line if cracked or worn. Install new filter. Wipe up any spilled fuel.

Start engine, and check for fuel leaks.

▲ Stop engine, tighten connections as necessary, and wipe up fuel.

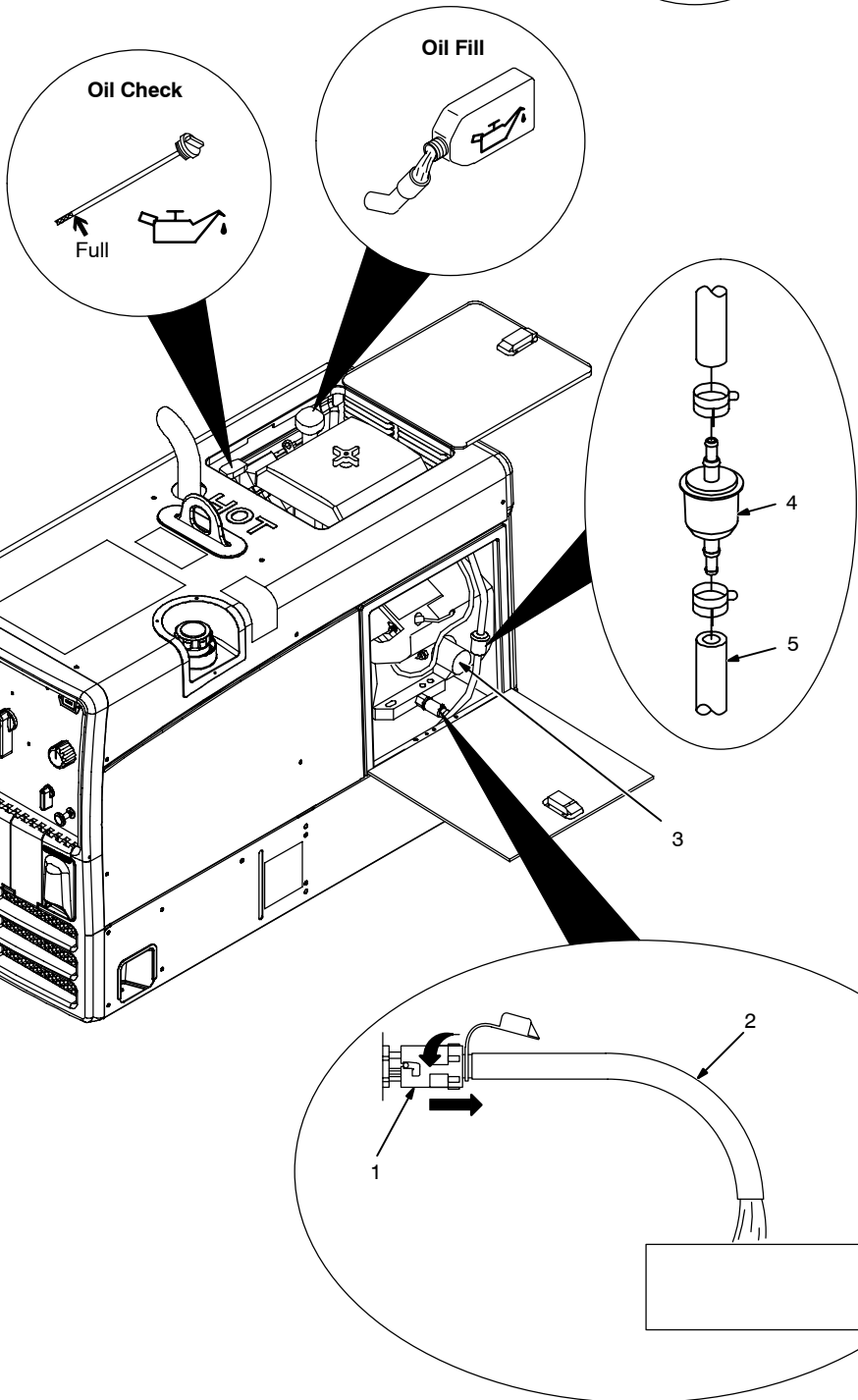

Tools Needed:

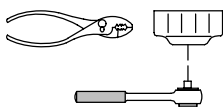

8-6. Adjusting Engine Speed (Robin-Powered Units)



	2200 - 2300 rpm (36.6 - 38.3 Hz)
	3675 - 3750 rpm (61.3 - 62.5 Hz)

After tuning engine, check engine speeds with a tachometer (see table). If necessary, adjust speeds as follows:

Start engine and run until warm.

Remove rear panel to access idle speed adjustments. Open top cover to access weld/power speed adjustments.

Idle Speed Adjustment

Move Engine Control switch to Run/Idle position.

- 1 Throttle Solenoid
- 2 Mounting Screws
- 3 Idle Speed Screw

Loosen mounting screws. Adjust solenoid position so engine runs at idle speed. If necessary, back out idle speed screw so solenoid can be moved to correct position. Tighten mounting screws. Be sure solenoid linkage works smoothly.

Turn idle speed screw for fine adjustments.

Weld/Power Speed Adjustment

Move Engine Control switch to Run position.

- 4 Jam Nut
- 5 Lock Nut
- 6 Weld/Power Speed Adjustment Screw

Loosen jam nut and lock nut. Turn adjustment screw until engine runs at weld/power speed. Tighten jam nut, and then tighten lock nut.

▲ Stop engine.

Reinstall end panel and/or close top cover.

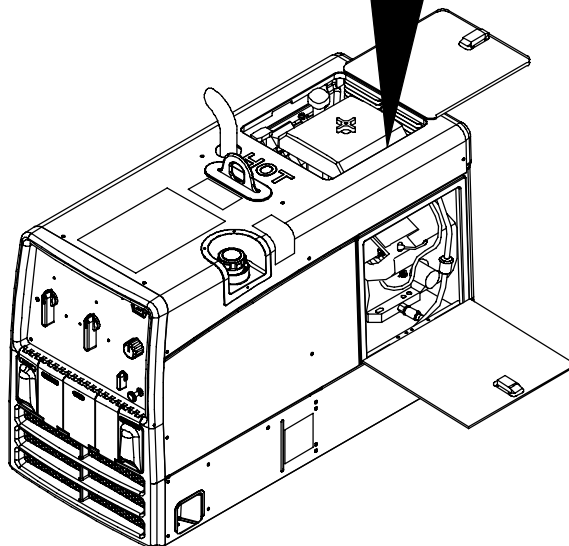
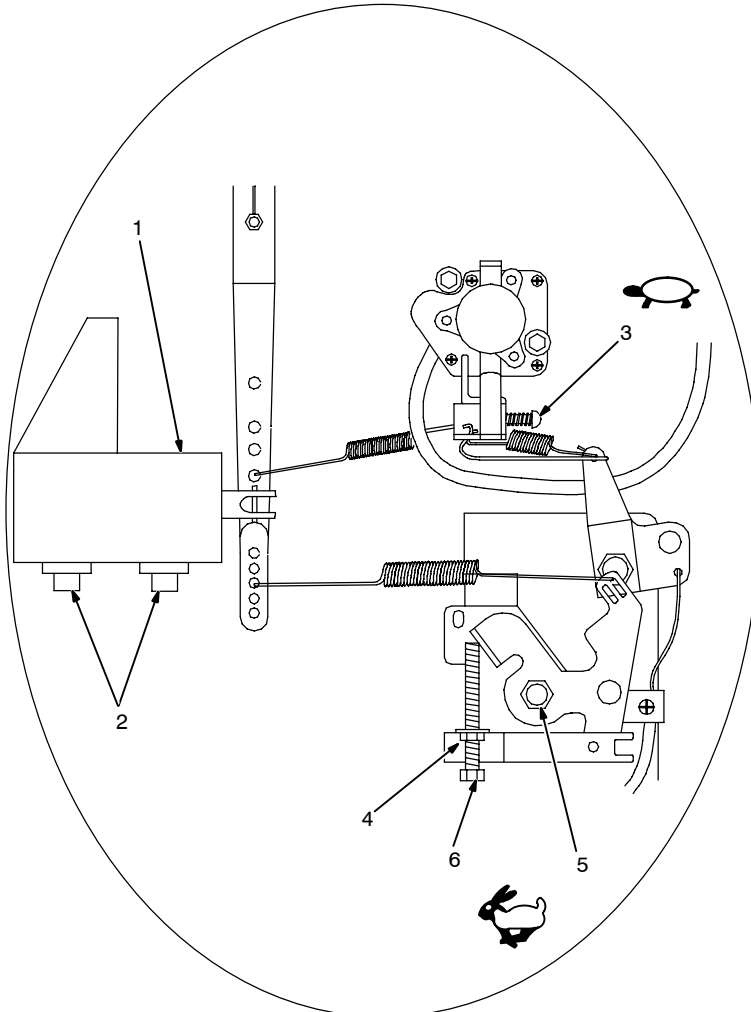

Tools Needed:

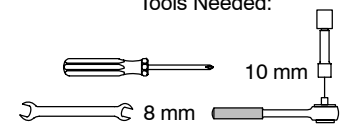

8-7. Servicing Optional Spark Arrestor (Robin-Powered Units)

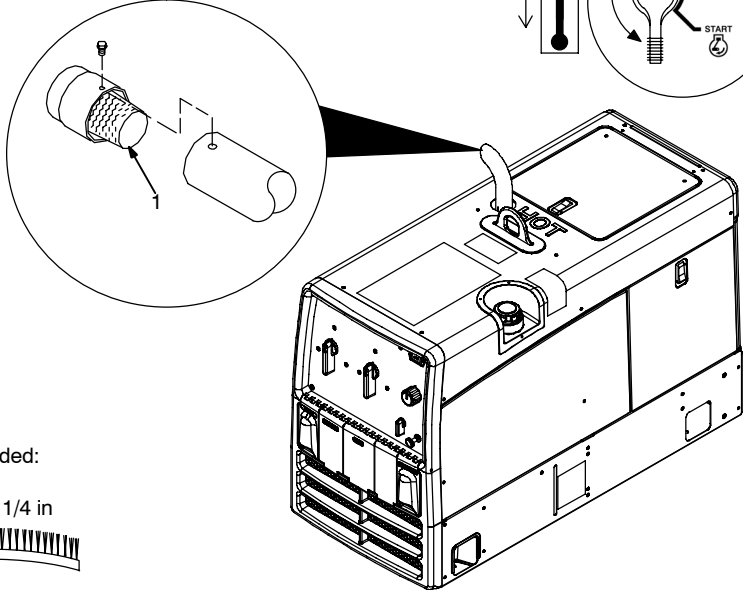



▲ Stop engine and let cool.

1 Spark Arrestor Screen

Clean and inspect screen. Replace spark arrestor if screen wires are broken or missing.

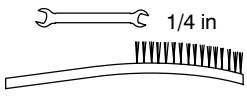
Tools Needed:



1/4 in

Ref. 801 682-A / Ref. 183 175-A

SECTION 9 – MAINTENANCE – (KOHLER-POWERED UNITS)

9-1. Maintenance Label (Kohler-Powered Units)

KOHLER CH20, ROBIN EH64/EH65 GAS ENGINES

See Engine Manual for complete engine care. Give Engine Specification and Serial Number when ordering parts.

 **Check Daily.**

Recommended Oil
API Service Classification . . . SG or higher
(If using LP fuel, use synthetic oil.)

Oil Change 100 hours
Oil Filter Change 200 hours
Oil Filter KOHLER: MILLER 066 698, Kohler 1205001
ROBIN: MILLER 198 754, Robin 248-85801-00

Oil Capacity w/filter change . . . Approximately 1.5 quarts

**DO NOT OVERFILL . . . KOHLER: Keep oil level between L & F marks on dipstick.
ROBIN: Keep oil level between 2 holes on dipstick.**

To Drain Oil:
Push And Turn CCW

Pull

		KOHLER		ROBIN	
°C	°F				
+38	+100				
+27	+80				
+10	+50				
0	+32				
-18	0				
-29	-20				
		10W-50	10W-50	30	30
		5W-50, 5W-50		10W-50, 10W-40	5W-50

 **Fuel Grade Unleaded, 87 Octane min.**
**Fuel Filter KOHLER: MILLER 215 984, Kohler 2505008
ROBIN: MILLER 215 984, Robin 283-85012-A3**

 **Air Filter Service 100 hours – see Owner's Manual**
Air Filter KOHLER: MILLER 067 272, Kohler 4708303
Air Filter Wrapper KOHLER: MILLER 067 273, Kohler 240B302
**Air Filter ROBIN: MILLER 198 755, Robin 283-32810-A1
(Includes Air Filter Wrapper)**

 **12 Volt Battery BCI Group 58**
Cranking Performance at 0°F (-18°C) . . . 430 Amps min.

 **Engine Speed**
No Load High Speed . . . 3675-3750 RPM
Idle 2200-2300 RPM
Miller Legend . . See Owner's Manual

 **Spark Plug KOHLER: MILLER 067 007, Kohler 1213202,
Champion RC-12YC**
**Gap: 0.030 in. ROBIN: MILLER 198 777, Robin X85-01407-30,
NGK BPR4EY**
Use only resistor spark plugs and wires.















Tune-up and Filter Kit . . (Includes Air, Oil and Fuel Filters, and 2 Spark Plugs)
KOHLER: MILLER 180 096
ROBIN: MILLER 199 082

215 938-C

OM-4419 Page 33

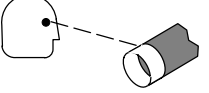
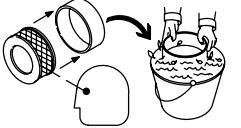
9-2. Routine Maintenance (Kohler-Powered Units)

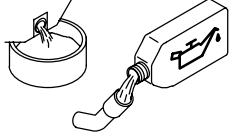
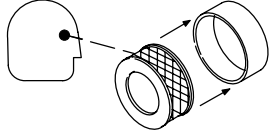
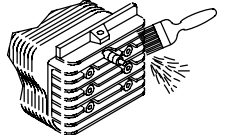
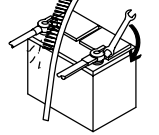
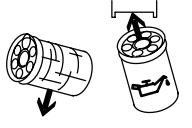
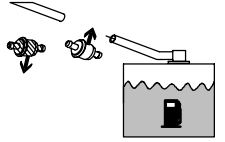
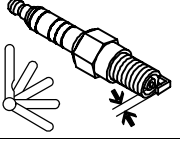
Note  Follow the storage procedure in the engine owner's manual if the unit will not be used for an extended period.

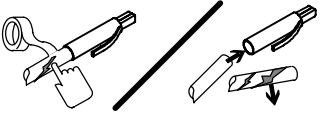
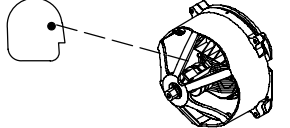
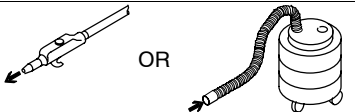
     		 <p>Recycle engine fluids.</p>	<p>▲ Stop engine before maintaining.</p> <p> See Engine Manual and Maintenance Label for important start-up, service, and storage information. Service engine more often if used in severe conditions.</p> <p>* To be done by Factory Authorized Service Agent.</p>
🕒 Every 8 h			
Wipe up spills.		Check fluid levels. See Section 5-3.	
🕒 Every 20 h		🕒 Every 25 h	
Check and clean optional spark arrestor screen. See Section 9-7.		Service air cleaner wrapper (foam element). See Section 9-3.	
🕒 Every 50 h			
Clean and tighten weld terminals.			
🕒 Every 100 h			
Change oil. See Section 9-4 and maintenance label.		Check air cleaner element. See Section 9-3.	
Clean cooling system. See Engine Manual.		Clean and tighten battery connections.	
🕒 Every 200 h			
Change oil filter. See Section 9-4 and maintenance label.		Replace fuel filter. See Section 9-4.	
Check spark plugs.		Replace unreadable labels.	
🕒 Every 500 h			
Repair or replace cracked cables.		Service welding generator brushes and slip rings. Service more often in dirty conditions.*	
🕒 Every 1000 h			
Blow out or vacuum inside. During heavy service, clean monthly.			

9-4. Changing Engine Oil, Oil Filter, and Fuel Filter (Kohler-Powered Units)

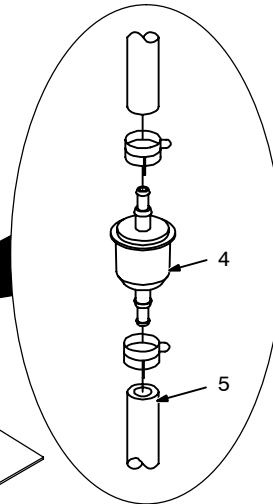
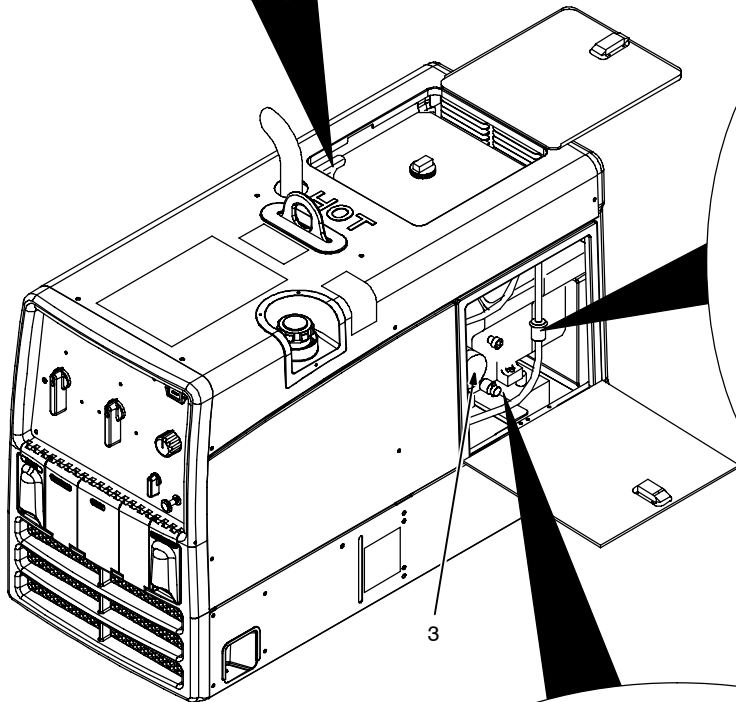
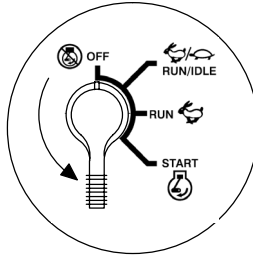
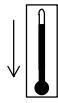
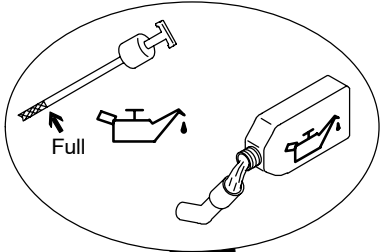

▲ **Stop engine and let cool.**

- 1 Oil Drain Valve
- 2 1/2 ID x 12 in Hose
- 3 Oil Filter

Change engine oil and filter according to engine owner's manual.

▲ **Close valve and valve cap before adding oil and running engine.**

Fill crankcase with new oil to full mark on dipstick (see Section 9-1).

- 4 Fuel Filter
- 5 Fuel Line

Replace line if cracked or worn. Install new filter. Wipe up any spilled fuel.

Start engine, and check for fuel leaks.

▲ **Stop engine, tighten connections as necessary, and wipe up fuel.**

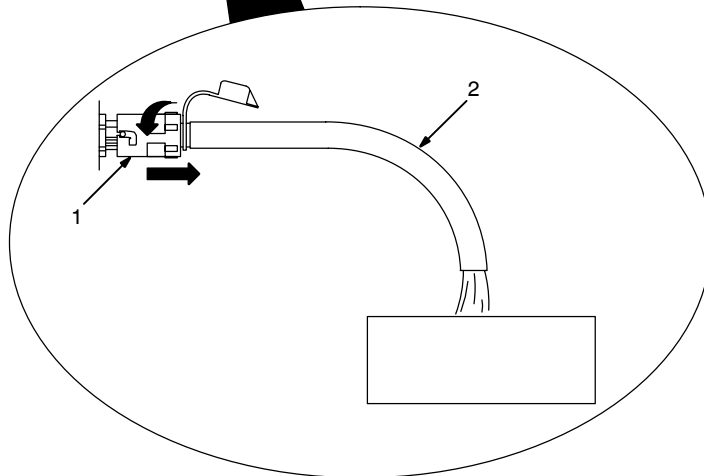

Tools Needed:

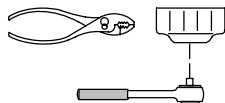

9-5. Adjusting Engine Speed (Kohler-Powered Units)



	2200 - 2300 rpm (36.6 - 38.3 Hz)
	3675 - 3750 rpm (61.3 - 62.5 Hz)

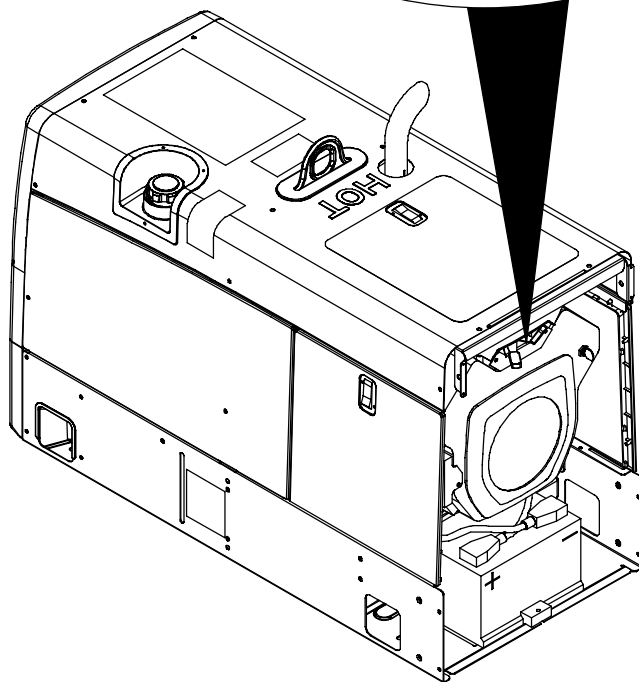
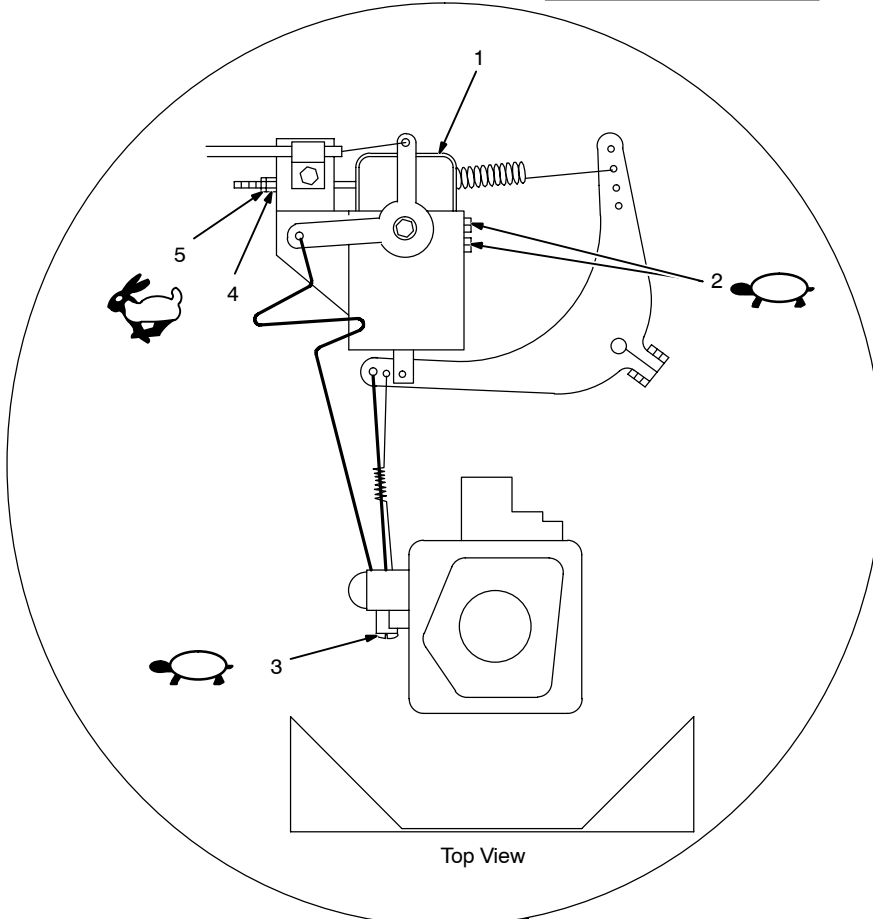

After tuning engine, check engine speeds with a tachometer (see table). If necessary, adjust speeds as follows:

Start engine and run until warm. Turn Fine Control to 10.

Remove rear panel to access idle speed adjustments. Open top cover to access weld/power speed adjustments.

Idle Speed Adjustment

Move Engine Control switch to Run/Idle position.

- 1 Throttle Solenoid
- 2 Mounting Screws
- 3 Idle Speed Screw

Loosen mounting screws. Adjust solenoid position so engine runs at idle speed. If necessary, back out idle speed screw so solenoid can be moved to correct position. Tighten mounting screws. Be sure solenoid linkage works smoothly.

Turn idle speed screw for fine adjustments.

Weld/Power Speed Adjustment

Move Engine Control switch to Run position.

- 4 Weld/Power Speed Adjustment Nut
- 5 Lock Nut

Loosen lock nut. Turn adjustment nut until engine runs at weld/power speed. Tighten lock nut.

Reinstall end panel and/or close top cover.

▲ Stop engine.

Tools Needed:

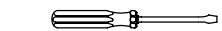

1/4, 3/8 in

9-6. Overload Protection (Kohler-Powered Units)

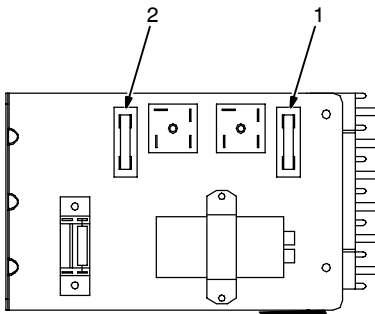
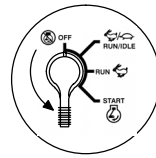

Fuses located on bracket behind left side panel.

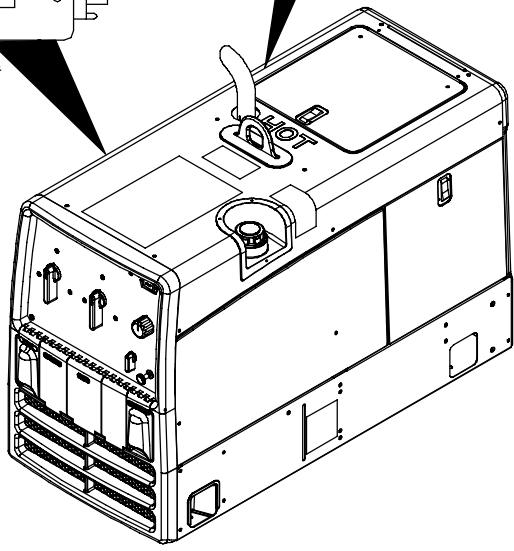
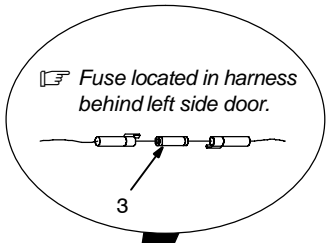

▲ **Stop engine. Disconnect negative (-) battery cable.**

1 Fuse F1 (See Parts List)

F1 protects the weld excitation winding from overload. If F1 opens, weld output stops or is low.

2 Fuse F2 (See Parts List)

F2 protects the generator power excitation winding from overload. If F2 opens, generator power output stops or is low.

3 Fuse F6 (See Parts List)

F6 protects the engine wiring system from overload. If F6 opens, engine will not crank.

Replace any open fuses. Reinstall cover before operating.

If a fuse opens, it usually indicates a more serious problem exists. Contact a Factory Authorized Service Agent.

Tools Needed:

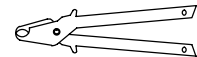

3/8 in

803 753

9-7. Servicing Optional Spark Arrestor (Kohler-Powered Units)

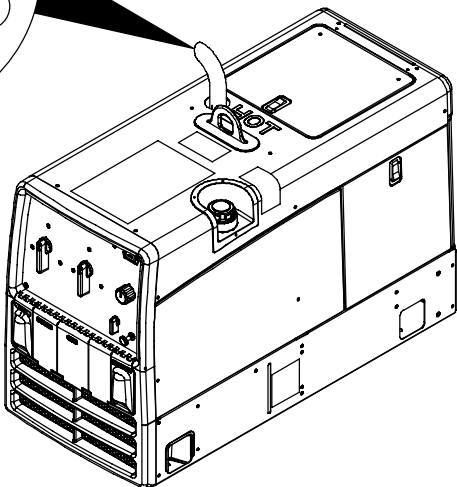
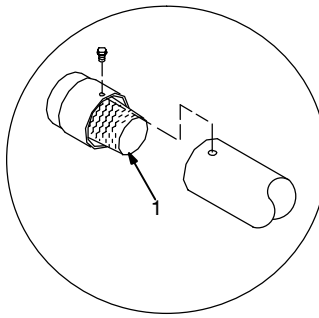
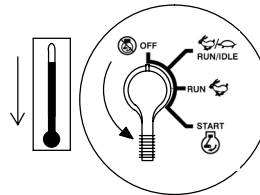
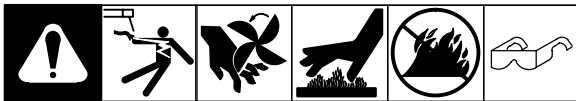

▲ **Stop engine and let cool.**

1 Spark Arrestor Screen

Clean and inspect screen. Replace spark arrestor if screen wires are broken or missing.

Tools Needed:

1/4 in



803 755 / Ref. 801 682-A

SECTION 10 – TROUBLESHOOTING

10-1. Welding Troubleshooting

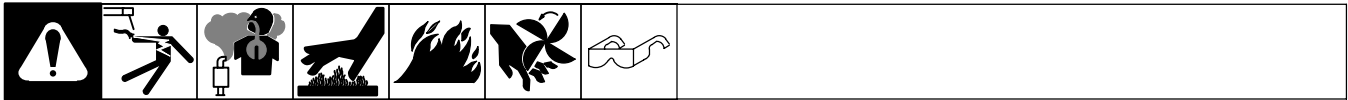

Trouble	Remedy
Low or no weld output; generator power output okay at ac receptacles.	Check control settings.
	Check weld connections.
	Check fuse F1, and replace if open (see Section 8-4 or 9-6).
	Have Factory Authorized Service Agent check brushes, slip rings, and integrated rectifiers SR2 and SR3.
No weld output or generator power output at ac receptacles.	Be sure all equipment is disconnected from receptacles when starting unit.
	Check fuses F1 and F2, and replace if open (see Section 8-4 or 9-6).
	Check plug PLG6 connection.
	Have Factory Authorized Service Agent check brushes, slip rings, and integrated rectifiers SR2, SR3.
Low weld output.	Check fuse F1, and replace if open (see Section 8-4 or 9-6).
	Check control settings.
	Check engine speed, and adjust if necessary (see Section 8-6 or 9-5).
	Service air cleaner according to engine manual.
	Have Factory Authorized Service Agent check brushes, slip rings, and integrated rectifiers SR2, SR3.
High weld output.	Check control settings.
	Check engine speed, and adjust if necessary (see Section 8-6 or 9-5).
Erratic weld output.	Check control settings.
	Tighten and clean connections to electrode and workpiece.
	Use dry, properly-stored electrodes for Stick and TIG welding.
	Remove excessive coils from weld cables.
	Clean and tighten connections both inside and outside welding generator.
	Check engine speed, and adjust if necessary (see Section 8-6 or 9-5).
	Have Factory Authorized Service Agent check brushes, slip rings, and integrated rectifiers SR2, SR3.

10-2. Generator Power Troubleshooting

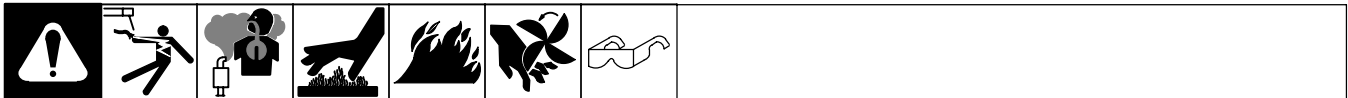

Trouble	Remedy
No or low generator power output at ac receptacles; weld output okay.	Reset circuit breakers (see Section 7-1 or 7-2).
	Press optional GFCI receptacle Reset button (see Section 7-2).
	Check fuse F2, and replace if open (see Section 8-4 or 9-6).
	Check plug PLG6 connection.
	Have Factory Authorized Service Agent check brushes, slip rings, and integrated rectifier SR3.
No generator power or weld output.	Be sure all equipment is disconnected from receptacles when starting unit.
	Check fuses F1 and F2, and replace if open (see Section 8-4 or 9-6).
	Check plug PLG6 connection.
	Have Factory Authorized Service Agent check brushes, slip rings, and integrated rectifiers SR2 and SR3.

Trouble	Remedy
Low power output at ac receptacles.	Check fuse F2, and replace if open (see Section 8-4 or 9-6).
	Increase Fine control R1 setting to max.
High power output at ac receptacles.	Check engine speed, and adjust if necessary (see Section 8-6 or 9-5).
Erratic power output at ac receptacles.	Check fuel level.
	Check engine speed, and adjust if necessary (see Section 8-6 or 9-5).
	Check receptacle wiring and connections.
	Have Factory Authorized Service Agent check brushes and slip rings.

10-3. Engine Troubleshooting

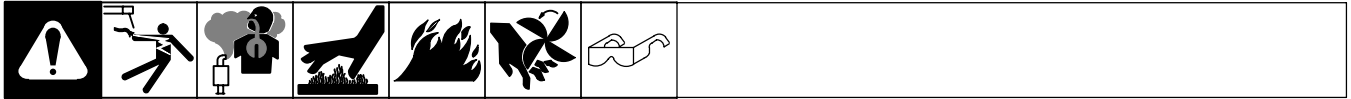

Trouble	Remedy
Engine will not crank.	Check fuse F6, and replace if open (see Section 8-4 or 9-6).
	Check battery voltage.
	Check battery connections and tighten if necessary.
	Check plug PLG4 and plug PLG8 connections.
	Have Factory Authorized Service Agent check Engine Control switch S2.
Engine will not start.	Check fuel level.
	Check battery voltage.
	Check battery connections and tighten if necessary.
	Check oil level (see Section 5-2 or 5-3).
	Check low oil pressure shutdown switch (see Parts List for location).
	Have Factory Authorized Service Agent check fuel shutoff solenoid FS1 (FS1 optional on Robin-powered units).
Engine starts but stops when Engine Control switch returns to Run position.	Check oil level.
	Check and refill crankcase with proper viscosity oil for operating temperature, if necessary.
	Check low oil pressure shutdown switch (see Parts List for location).
Engine stopped during normal operation.	Check fuel level.
	Check oil level (see Section 5-2 or 5-3).
	Check low oil pressure shutdown switch (see Parts List for location)
	Periodically recharge battery (approximately every 3 months).
	Replace battery.
	Check voltage regulator and connections according to engine manual.
	Have Factory Authorized Service Agent check fuel shutoff solenoid FS1 (FS1 optional on Robin-powered units).
Battery Discharges between uses.	Clean battery, terminals, and posts with baking soda and water solution; rinse with clear water.
	Periodically recharge battery (approximately every 3 months).
	Replace battery.
	Check voltage regulator and connections according to engine manual.
Engine idles but does not come up to weld speed.	Have Factory Authorized Service Agent check auto idle module PC1, and current transformer CT1.

SECTION 11 – ELECTRICAL DIAGRAMS

	WARNING	<ul style="list-style-type: none"> Do not touch live electrical parts. Disconnect input power or stop engine before servicing. Do not operate with covers removed. Have only qualified persons install, use, or service this unit.
	ELECTRIC SHOCK HAZARD	

(POSITION)		A	B	C	D	E	F
(TERMINAL)	S2	OFF	IDLE	RUN	START		
	RUN/IDLE	O	X				
	RUN		X	X	X		
	START					X	
	GROUND	O					

A	B	C	D	E	F
1T O	O	O	O	O	O
42	82	80	90	81	
42	82	80	90	81	
42		42			
42					

X = CLOSED TO "B" TERMINAL
 O = CLOSED TO BASE GROUND

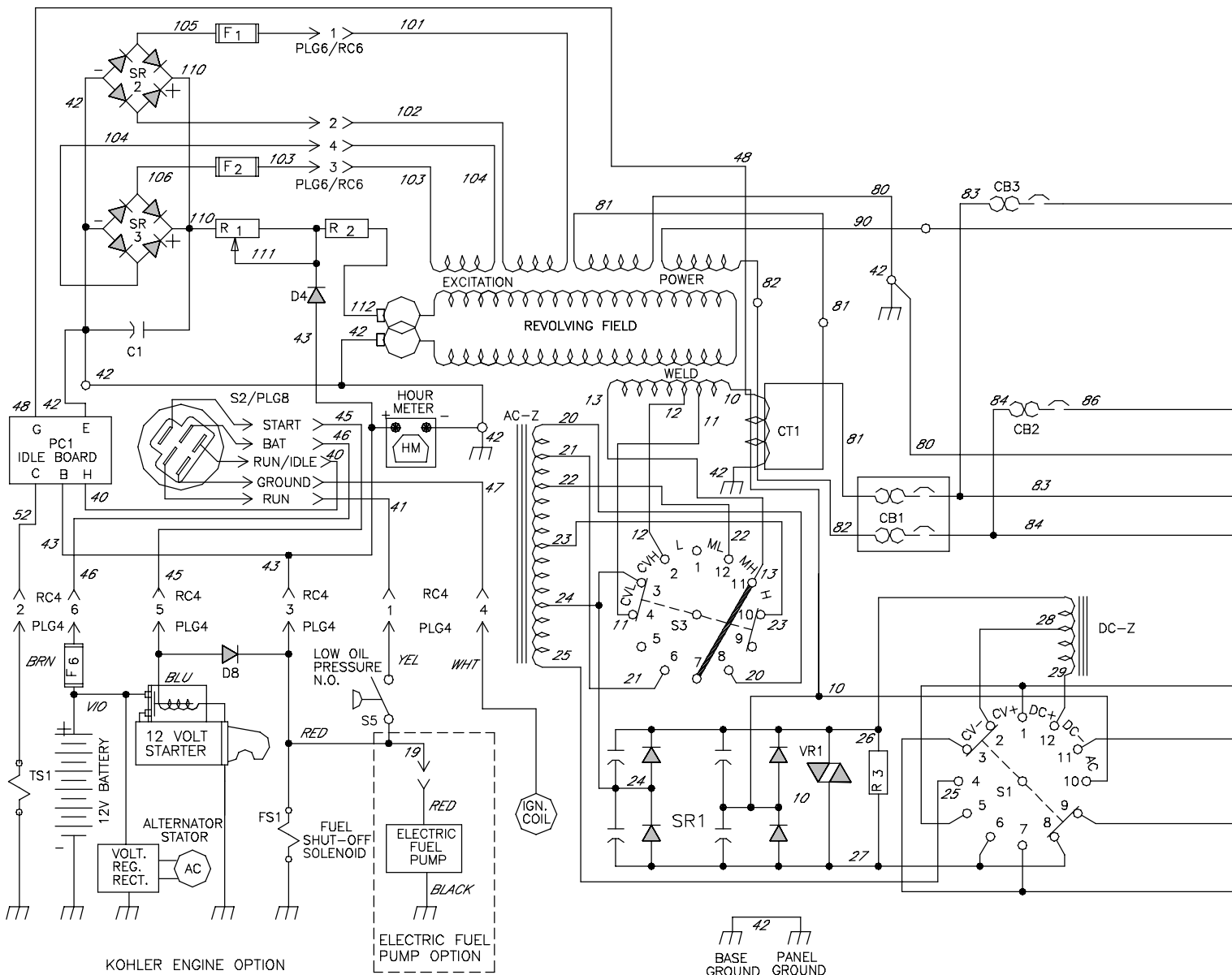
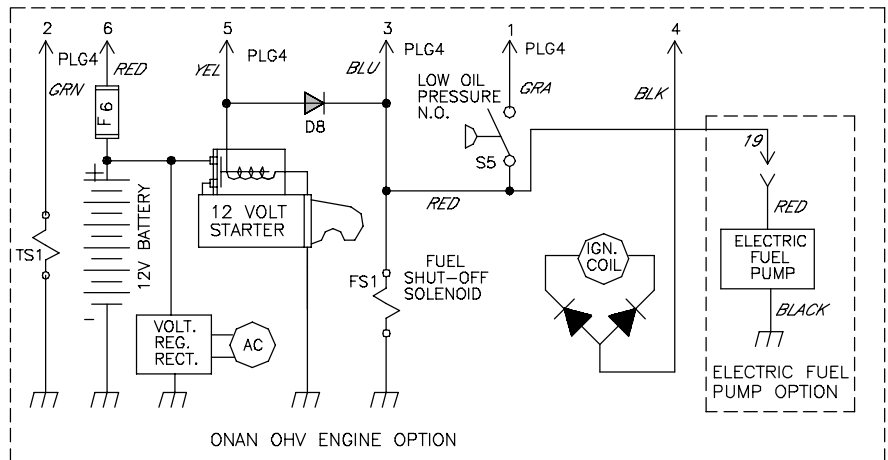
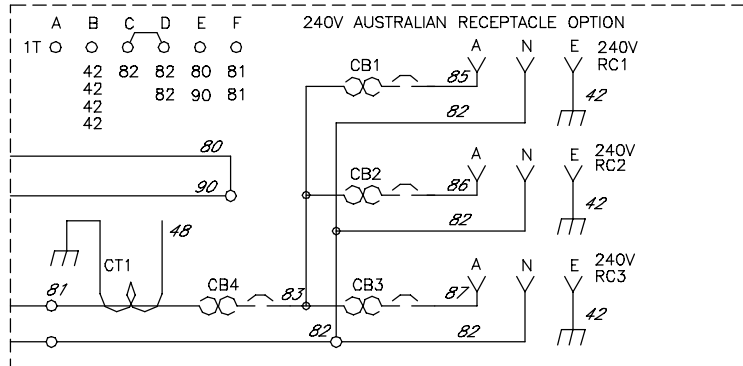
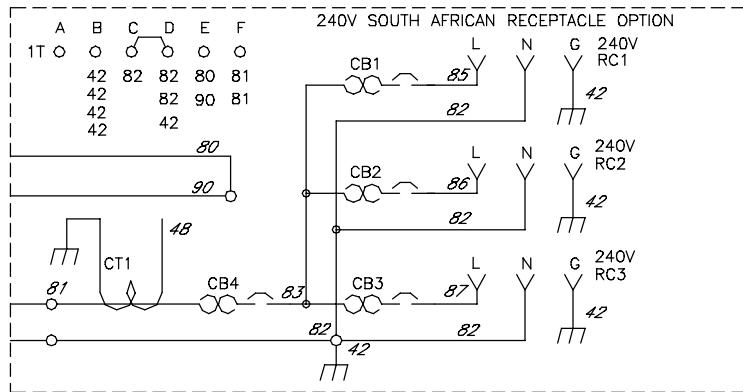
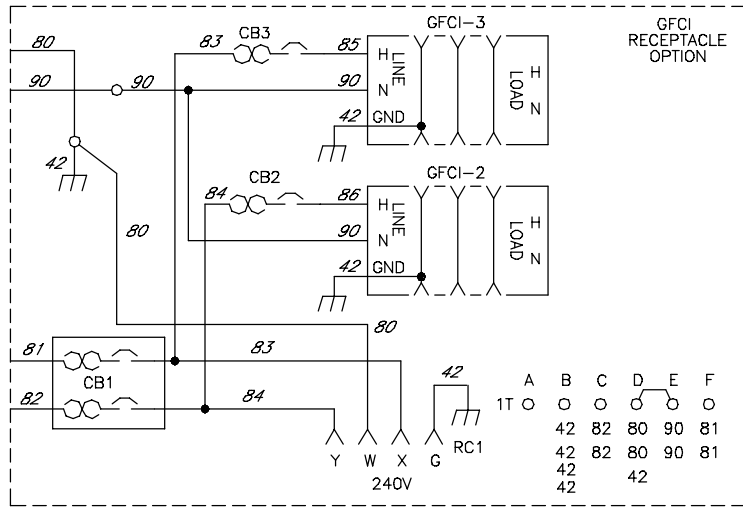
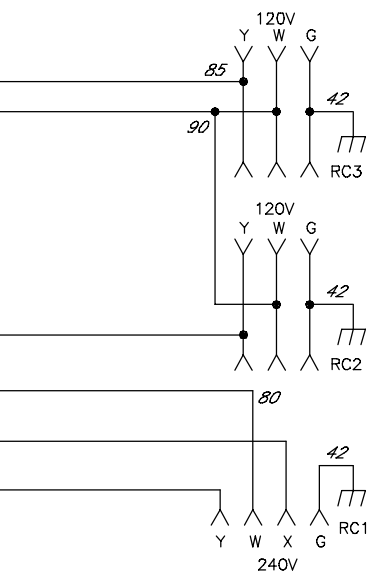

Figure 11-1. Circuit Diagram For Welding Generator





SECTION 12 – GENERATOR POWER GUIDELINES

NOTE

The views in this section are intended to be representative of all engine-driven welding generators. Your unit may differ from those shown.

12-1. Selecting Equipment



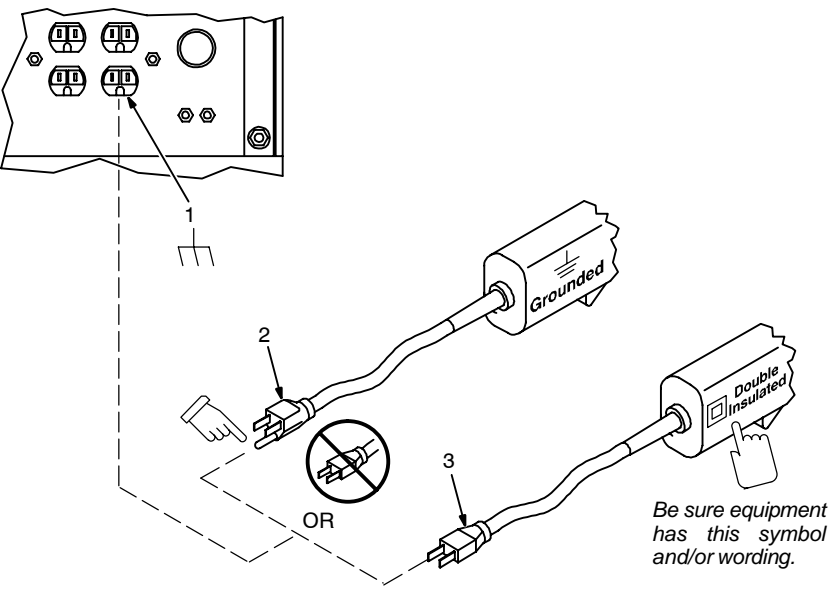

- 1 Generator Power Receptacles – Neutral Bonded To Frame
- 2 3-Prong Plug From Case Grounded Equipment
- 3 2-Prong Plug From Double Insulated Equipment

▲ **Do not use 2-prong plug unless equipment is double insulated.**

gen_pwr 11/02 – Ref. ST-159 730 / ST-800 577

12-2. Grounding Generator To Truck Or Trailer Frame

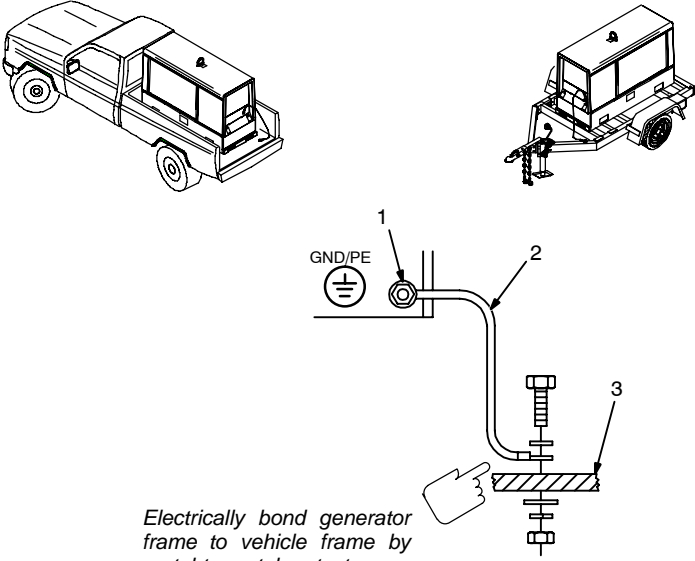

Electrically bond generator frame to vehicle frame by metal-to-metal contact.

▲ **Always ground generator frame to vehicle frame to prevent electric shock and static electricity hazards.**

- 1 Equipment Grounding Terminal (On Front Panel)
- 2 Grounding Cable (Not Supplied)
- 3 Metal Vehicle Frame

Connect cable from equipment ground terminal to metal vehicle frame. Use #10 AWG or larger insulated copper wire.

▲ **If unit does not have GFCI receptacles, use GFCI-protected extension cord.**

▲ **Bed liners, shipping skids, and some running gear insulate the welding generator from the vehicle frame. Always connect a ground wire from the generator equipment grounding terminal to bare metal on the vehicle frame as shown.**

S-0854

12-3. Grounding When Supplying Building Systems

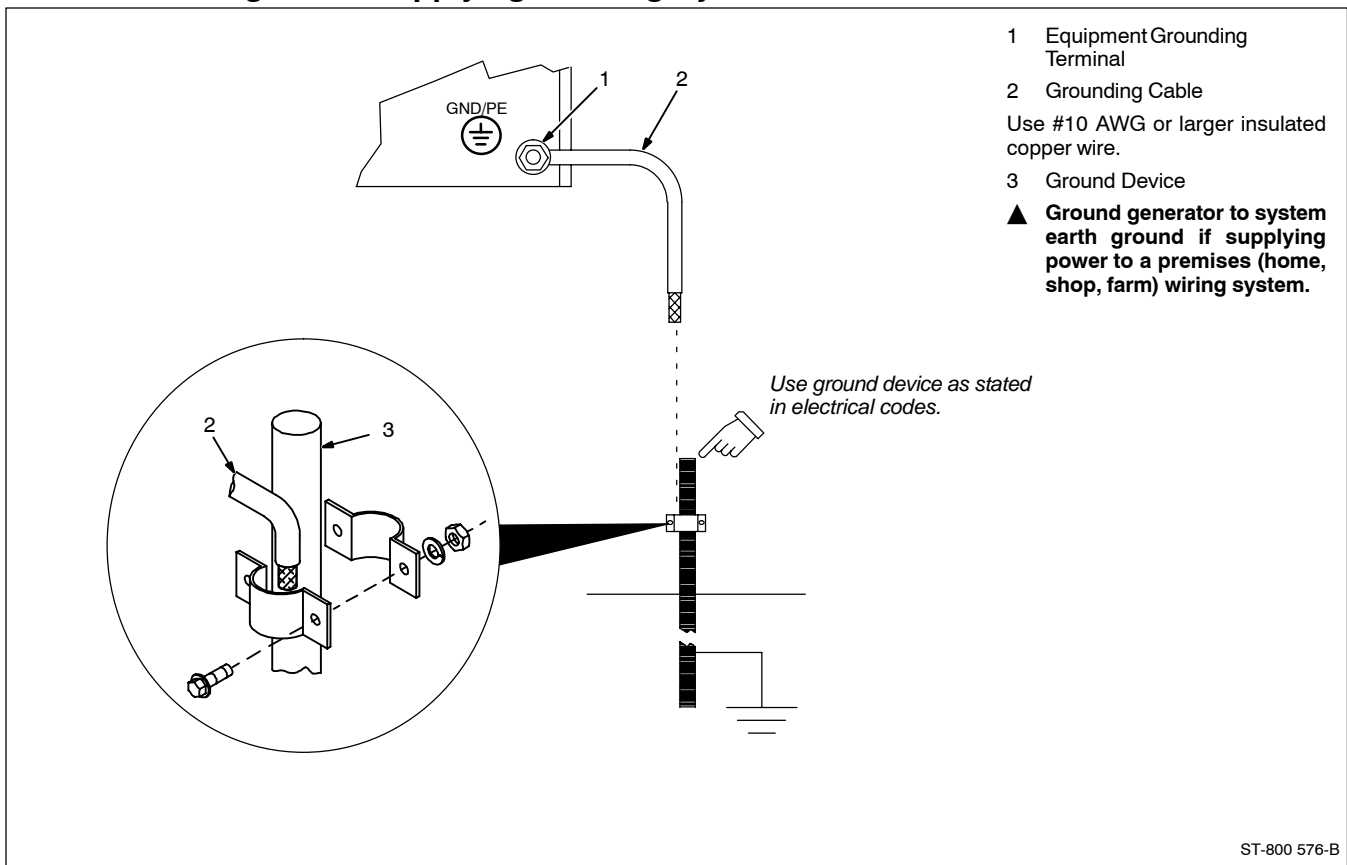

12-4. How Much Power Does Equipment Require?

1 Resistive Load
 A light bulb is a resistive load and requires a constant amount of power.

2 Non-Resistive Load
 Equipment with a motor is a non-resistive load and requires approximately six times more power while starting the motor than when running (see Section 12-8).

3 Rating Data
 Rating shows volts and amperes, or watts required to run equipment.

AMPERES x VOLTS = WATTS

EXAMPLE 1: If a drill uses 4.5 amperes at 115 volts, calculate its running power requirement in watts.

$$4.5 \text{ A} \times 115 \text{ V} = 520 \text{ W}$$

The load applied by the drill is 520 watts.

EXAMPLE 2: If three 200 watt flood lamps are used with the drill from Example 1, add the individual loads to calculate total load.

$$(200 \text{ W} + 200 \text{ W} + 200 \text{ W}) + 520 \text{ W} = 1120 \text{ W}$$

The total load applied by the three flood lamps and drill is 1120 watts.

S-0623

12-5. Approximate Power Requirements For Industrial Motors

Industrial Motors	Rating	Starting Watts	Running Watts
Split Phase	1/8 HP	800	300
	1/6 HP	1225	500
	1/4 HP	1600	600
	1/3 HP	2100	700
	1/2 HP	3175	875
Capacitor Start-Induction Run	1/3 HP	2020	720
	1/2 HP	3075	975
	3/4 HP	4500	1400
	1 HP	6100	1600
	1-1/2 HP	8200	2200
	2 HP	10550	2850
	3 HP	15900	3900
Capacitor Start-Capacitor Run	5 HP	23300	6800
	1-1/2 HP	8100	2000
	5 HP	23300	6000
	7-1/2 HP	35000	8000
Fan Duty	10 HP	46700	10700
	1/8 HP	1000	400
	1/6 HP	1400	550
	1/4 HP	1850	650
	1/3 HP	2400	800
	1/2 HP	3500	1100

12-6. Approximate Power Requirements For Farm/Home Equipment

Farm/Home Equipment	Rating	Starting Watts	Running Watts
Stock Tank De-Icer		1000	1000
Grain Cleaner	1/4 HP	1650	650
Portable Conveyor	1/2 HP	3400	1000
Grain Elevator	3/4 HP	4400	1400
Milk Cooler		2900	1100
Milker (Vacuum Pump)	2 HP	10500	2800
FARM DUTY MOTORS	1/3 HP	1720	720
Std. (e.g. Conveyors,	1/2 HP	2575	975
Feed Augers, Air	3/4 HP	4500	1400
Compressors)	1 HP	6100	1600
	1-1/2 HP	8200	2200
	2 HP	10550	2850
	3 HP	15900	3900
	5 HP	23300	6800
High Torque (e.g. Barn	1-1/2 HP	8100	2000
Cleaners, Silo Unloaders,	5 HP	23300	6000
Silo Hoists, Bunk Feeders)	7-1/2 HP	35000	8000
	10 HP	46700	10700
3-1/2 cu. ft. Mixer	1/2 HP	3300	1000
High Pressure 1.8 Gal/Min	500 PSI	3150	950
Washer 2 gal/min	550 PSI	4500	1400
2 gal/min	700 PSI	6100	1600
Refrigerator or Freezer		3100	800
Shallow Well Pump	1/3 HP	2150	750
	1/2 HP	3100	1000
Sump Pump	1/3 HP	2100	800
	1/2 HP	3200	1050

12-7. Approximate Power Requirements For Contractor Equipment

Contractor	Rating	Starting Watts	Running Watts
Hand Drill	1/4 in	350	350
	3/8 in	400	400
	1/2 in	600	600
Circular Saw	6-1/2 in	500	500
	7-1/4 in	900	900
	8-1/4 in	1400	1400
Table Saw	9 in	4500	1500
	10 in	6300	1800
Band Saw	14 in	2500	1100
Bench Grinder	6 in	1720	720
	8 in	3900	1400
	10 in	5200	1600
Air Compressor	1/2 HP	3000	1000
	1 HP	6000	1500
	1-1/2 HP	8200	2200
	2 HP	10500	2800
Electric Chain Saw	1-1/2 HP, 12 in	1100	1100
	2 HP, 14 in	1100	1100
Electric Trimmer	Standard 9 in	350	350
	Heavy Duty 12 in	500	500
Electric Cultivator	1/3 HP	2100	700
Elec. Hedge Trimmer	18 in	400	400
Flood Lights	HID	125	100
	Metal Halide	313	250
	Mercury	1000	
	Sodium Vapor	1400	1000
Submersible Pump	400 gph	600	200
Centrifugal Pump	900 gph	900	500
Floor Polisher	3/4 HP, 16 in	4500	1400
	1 HP, 20 in	6100	1600
High Pressure Washer	1/2 HP	3150	950
	3/4 HP	4500	1400
	1 HP	6100	1600
55 gal Drum Mixer	1/4 HP	1900	700
Wet & Dry Vac	1.7 HP	900	900
	2-1/2 HP	1300	1300

12-8. Power Required To Start Motor

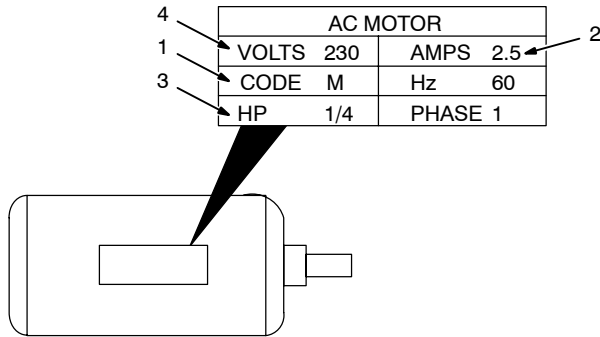

- 1 Motor Start Code
- 2 Running Amperage
- 3 Motor HP
- 4 Motor Voltage

To find starting amperage:

Step 1: Find code and use table to find kVA/HP. If code is not listed, multiply running amperage by six to find starting amperage.

Step 2: Find Motor HP and Volts.

Step 3: Determine starting amperage (see example).

Welding generator amperage output must be at least twice the motor's running amperage.

Single-Phase Induction Motor Starting Requirements

Motor Start Code	G	H	J	K	L	M	N	P
KVA/HP	6.3	7.1	8.0	9.0	10.0	11.2	12.5	14.0

$$\frac{\text{kVA/HP} \times \text{HP} \times 1000}{\text{VOLTS}} = \text{STARTING AMPERAGE}$$

EXAMPLE: Calculate the starting amperage required for a 230 V, 1/4 HP motor with a motor start code of M.

Volts = 230 HP = 1/4 Using Table, Code M results in kVA/HP = 11.2

$$\frac{11.2 \times 1/4 \times 1000}{230} = 12.2 \text{ A} \quad \text{Starting the motor requires 12.2 amperes.}$$

S-0624

12-9. How Much Power Can Generator Supply?

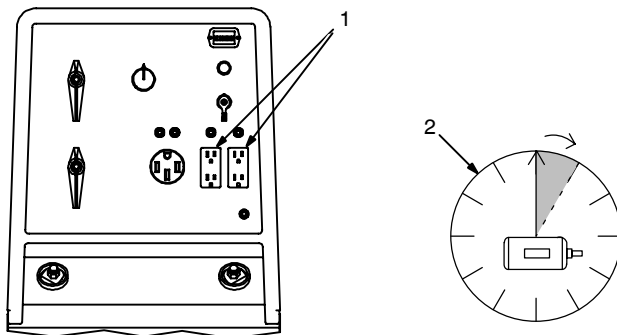

- 1 Limit Load To 90% Of Generator Output

Always start non-resistive (motor) loads in order from largest to smallest, and add resistive loads last.

- 2 5 Second Rule

If motor does not start within 5 seconds, turn off power to prevent motor damage. Motor requires more power than generator can supply.

Ref. ST-800 396-A / S-0625

12-11. Selecting Extension Cord (Use Shortest Cord Possible)



Cord Lengths for 120 Volt Loads

▲ If unit does not have GFCI receptacles, use GFCI-protected extension cord.

Current (Amperes)	Load (Watts)	Maximum Allowable Cord Length in ft (m) for Conductor Size (AWG)*					
		4	6	8	10	12	14
5	600			350 (106)	225 (68)	137 (42)	100 (30)
7	840		400 (122)	250 (76)	150 (46)	100 (30)	62 (19)
10	1200	400 (122)	275 (84)	175 (53)	112 (34)	62 (19)	50 (15)
15	1800	300 (91)	175 (53)	112 (34)	75 (23)	37 (11)	30 (9)
20	2400	225 (68)	137 (42)	87 (26)	50 (15)	30 (9)	
25	3000	175 (53)	112 (34)	62 (19)	37 (11)		
30	3600	150 (46)	87 (26)	50 (15)	37 (11)		
35	4200	125 (38)	75 (23)	50 (15)			
40	4800	112 (34)	62 (19)	37 (11)			
45	5400	100 (30)	62 (19)				
50	6000	87 (26)	50 (15)				

*Conductor size is based on maximum 2% voltage drop

Cord Lengths for 240 Volt Loads

▲ If unit does not have GFCI receptacles, use GFCI-protected extension cord.

Current (Amperes)	Load (Watts)	Maximum Allowable Cord Length in ft (m) for Conductor Size (AWG)*					
		4	6	8	10	12	14
5	1200			700 (213)	450 (137)	225 (68)	200 (61)
7	1680		800 (244)	500 (152)	300 (91)	200 (61)	125 (38)
10	2400	800 (244)	550 (168)	350 (107)	225 (69)	125 (38)	100 (31)
15	3600	600 (183)	350 (107)	225 (69)	150 (46)	75 (23)	60 (18)
20	4800	450 (137)	275 (84)	175 (53)	100 (31)	60 (18)	
25	6000	350 (107)	225 (69)	125 (38)	75 (23)		
30	7000	300 (91)	175 (53)	100 (31)	75 (23)		
35	8400	250 (76)	150 (46)	100 (31)			
40	9600	225 (69)	125 (38)	75 (23)			
45	10,800	200 (61)	125 (38)				
50	12,000	175 (53)	100 (31)				

*Conductor size is based on maximum 2% voltage drop

SECTION 13 – STICK WELDING (SMAW) GUIDELINES



13-1. Stick Welding Procedure

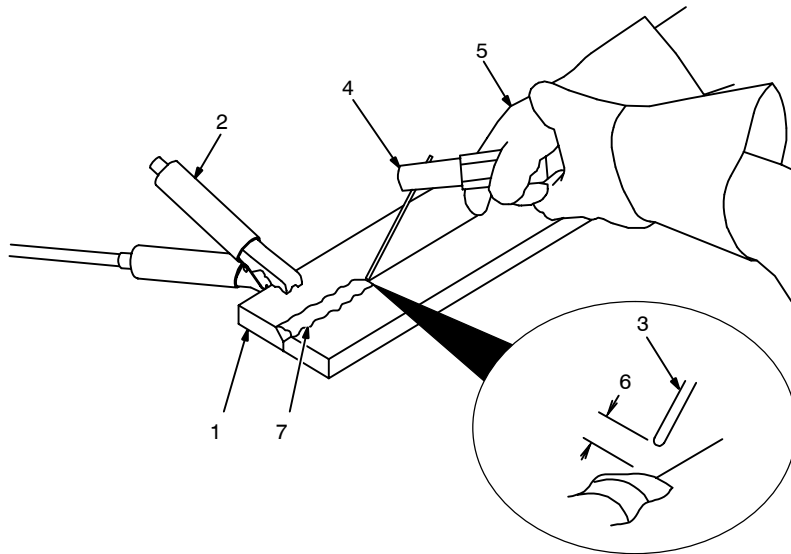

▲ Weld current starts when electrode touches workpiece.

▲ Weld current can damage electronic parts in vehicles. Disconnect both battery cables before welding on a vehicle. Place work clamp as close to the weld as possible.

1 Workpiece

Make sure workpiece is clean before welding.

2 Work Clamp

3 Electrode

A small diameter electrode requires less current than a large one. Follow electrode manufacturer's instructions when setting weld amperage (see Section 13-2).

4 Insulated Electrode Holder

5 Electrode Holder Position

6 Arc Length

Arc length is the distance from the electrode to the workpiece. A short arc with correct amperage will give a sharp, crackling sound.

7 Slag

Use a chipping hammer and wire brush to remove slag. Remove slag and check weld bead before making another weld pass.

Tools Needed:

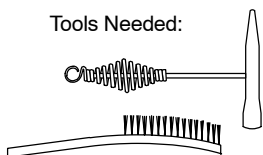

13-2. Electrode and Amperage Selection Chart

ELECTRODE	DIAMETER	AMPERAGE RANGE								
		50	100	150	200	250	300	350	400	450
6010 & 6011	3/32									
	1/8									
	5/32									
	3/16									
	7/32									
6013	1/4									
	1/16									
	5/64									
	3/32									
	1/8									
	5/32									
	3/16									
7014	7/32									
	1/4									
	3/32									
	1/8									
	5/32									
7018	3/16									
	7/32									
	1/4									
	3/32									
	1/8									
7024	5/32									
	3/16									
	7/32									
	1/4									
	3/32									
Ni-CI	1/8									
	5/32									
	3/16									
308L	3/32									
	1/8									
	5/32									

ELECTRODE	DC*	AC	POSITION	PENETRATION	USAGE
6010	EP		ALL	DEEP	MIN. PREP, ROUGH
6011	EP	✓	ALL	DEEP	HIGH SPATTER
6013	EP,EN	✓	ALL	LOW	GENERAL
7014	EP,EN	✓	ALL	MED	SMOOTH, EASY, FAST
7018	EP	✓	ALL	LOW	LOW HYDROGEN, STRONG
7024	EP,EN	✓	FLAT HORIZ FILLET	LOW	SMOOTH, EASY, FASTER
NI-CL	EP	✓	ALL	LOW	CAST IRON
308L	EP	✓	ALL	LOW	STAINLESS

*EP = ELECTRODE POSITIVE (REVERSE POLARITY)
EN = ELECTRODE NEGATIVE (STRAIGHT POLARITY)

Ref. S-087 985-A

13-3. Striking an Arc – Scratch Start Technique

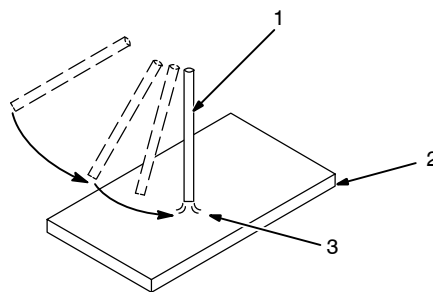

- 1 Electrode
- 2 Workpiece
- 3 Arc

Drag electrode across workpiece like striking a match; lift electrode slightly after touching work. If arc goes out electrode was lifted too high. If electrode sticks to workpiece, use a quick twist to free it.

S-0049

13-4. Striking an Arc – Tapping Technique

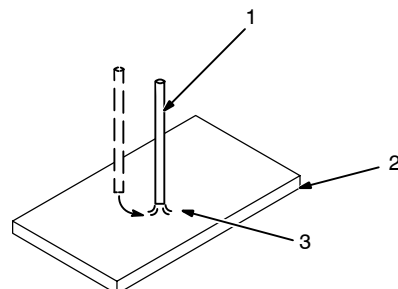

- 1 Electrode
- 2 Workpiece
- 3 Arc

Bring electrode straight down to workpiece; then lift slightly to start arc. If arc goes out, electrode was lifted too high. If electrode sticks to workpiece, use a quick twist to free it.

S-0050

13-5. Positioning Electrode Holder

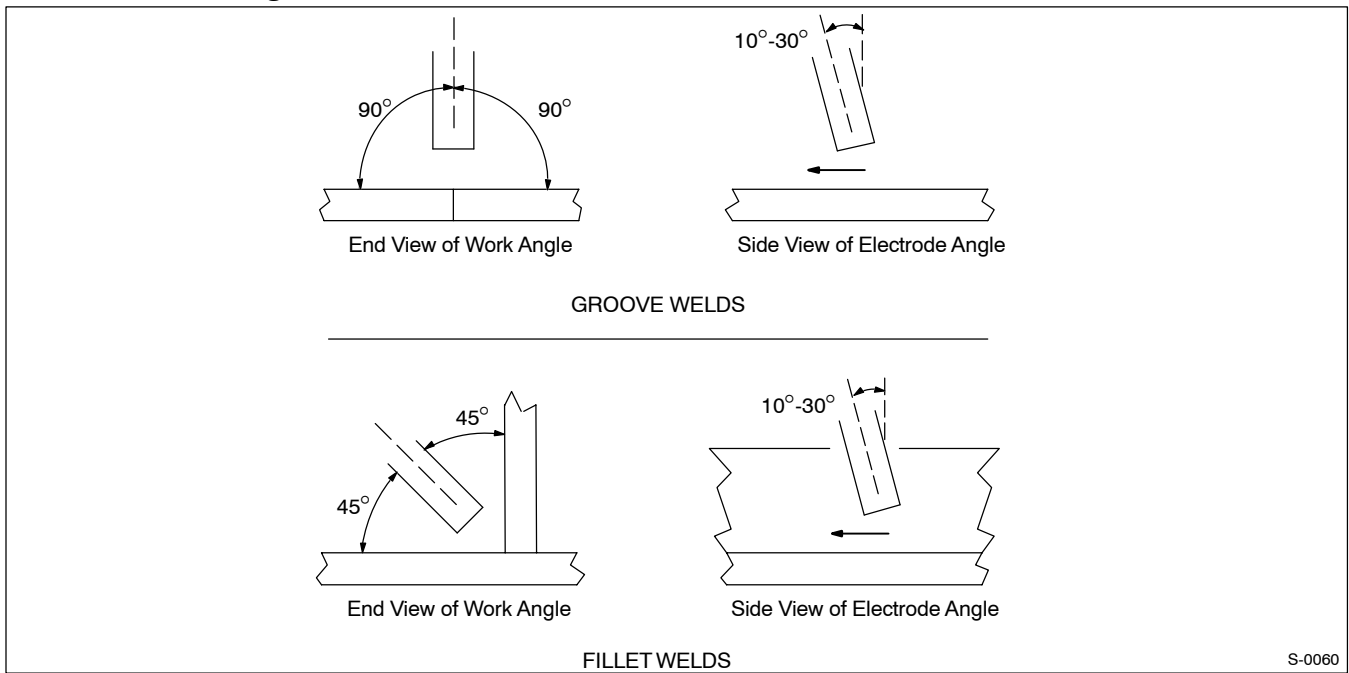

13-6. Poor Weld Bead Characteristics

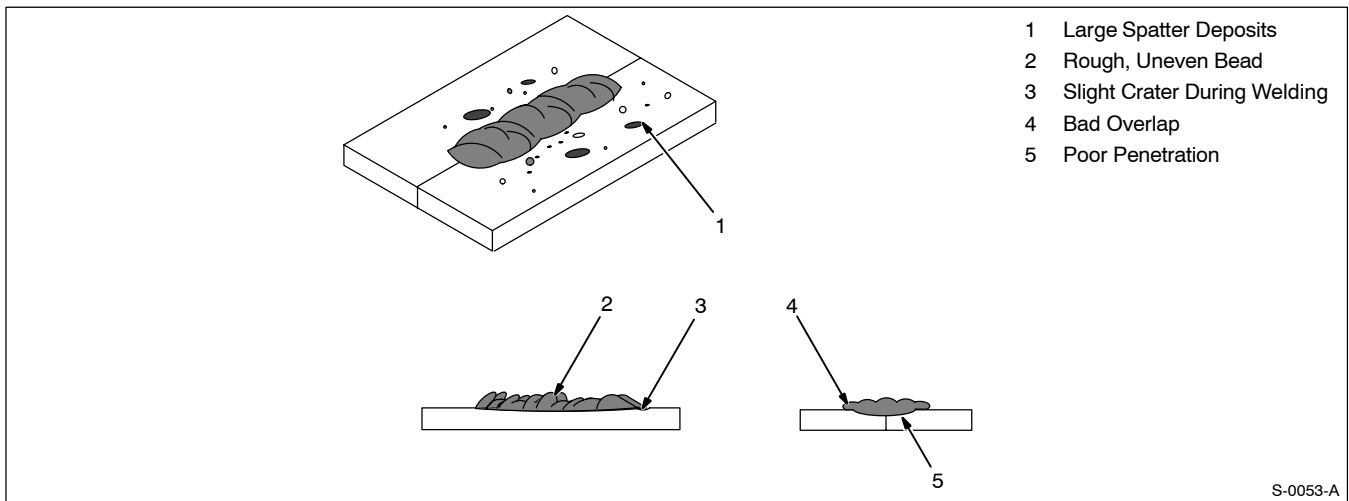

13-7. Good Weld Bead Characteristics

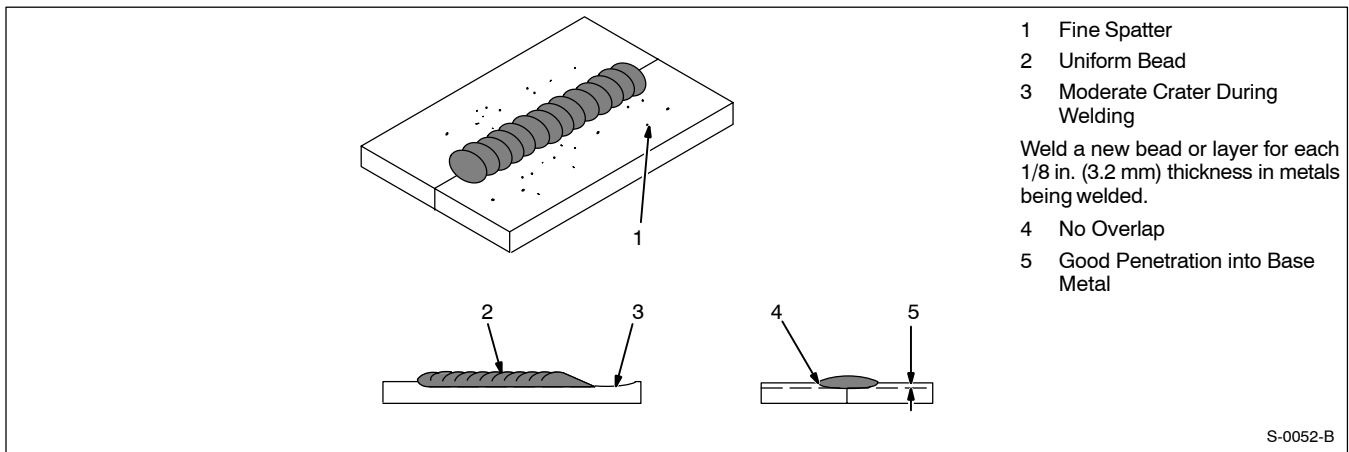

13-8. Conditions That Affect Weld Bead Shape

NOTE 

Weld bead shape is affected by electrode angle, arc length, travel speed, and thickness of base metal.

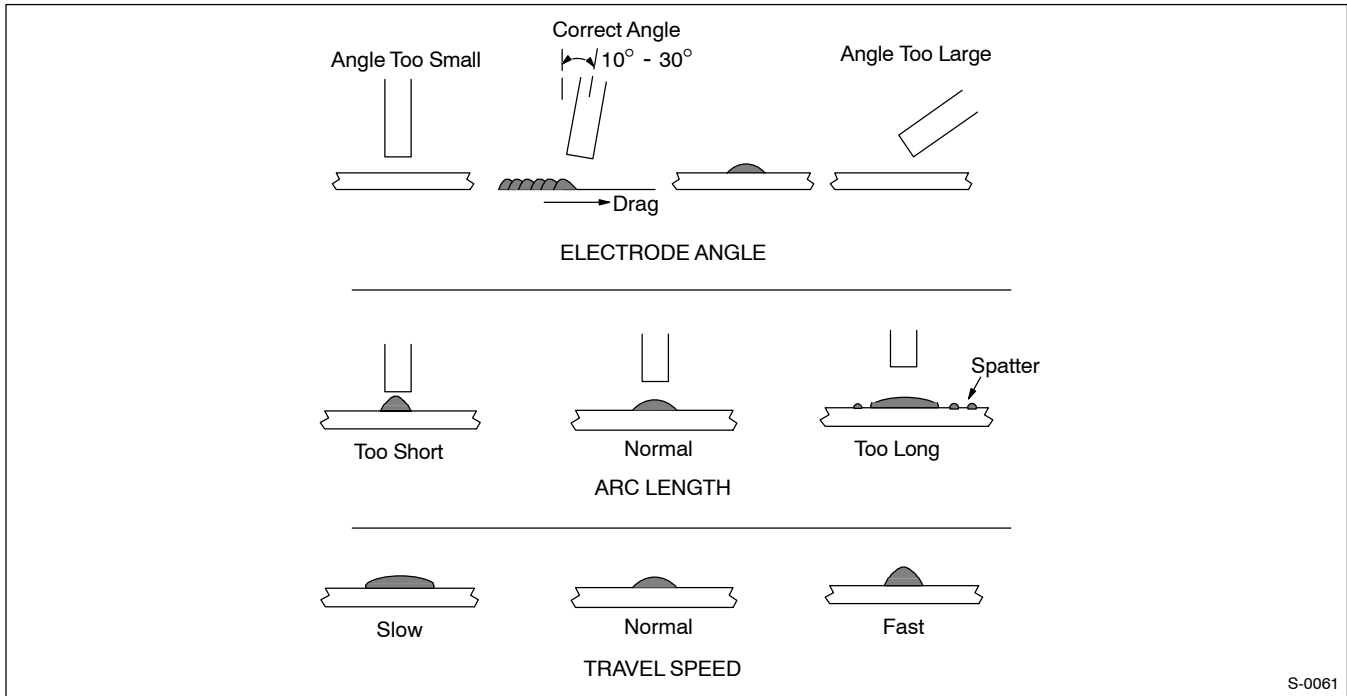

13-9. Electrode Movement During Welding

NOTE 

Normally, a single stringer bead is satisfactory for most narrow groove weld joints; however, for wide groove weld joints or bridging across gaps, a weave bead or multiple stringer beads work better.

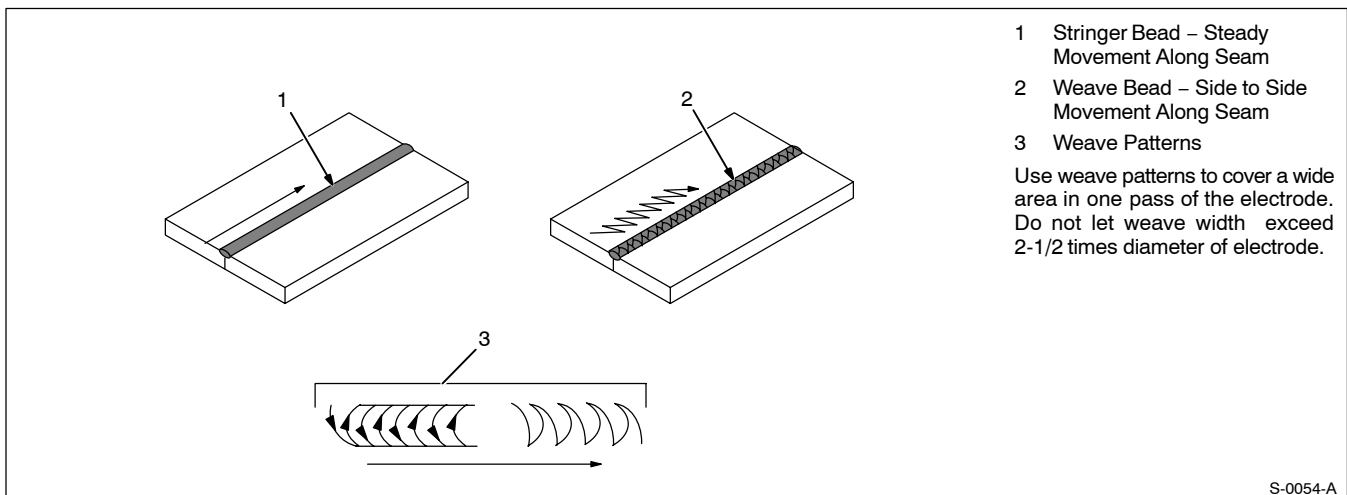

13-10. Butt Joints

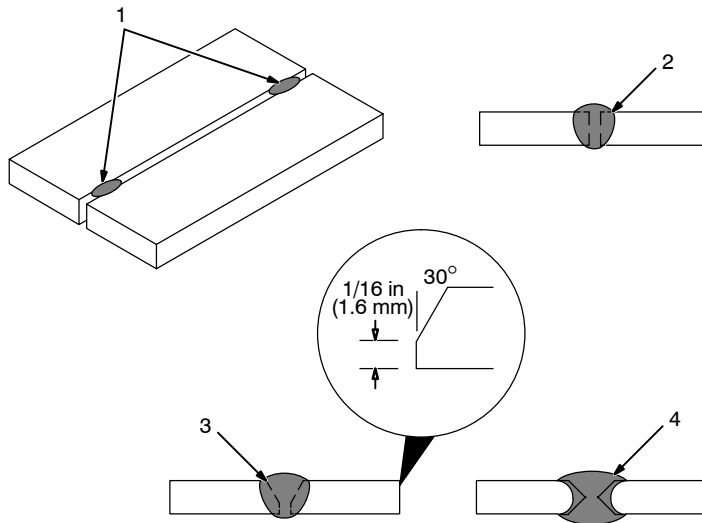

1 Tack Welds

Prevent edges of joint from drawing together ahead of electrode by tack welding the materials in position before final weld.

2 Square Groove Weld

Good for materials up to $3/16$ in (5 mm) thick.

3 Single V-Groove Weld

Good for materials $3/16$ – $3/4$ in (5-19 mm) thick. Cut bevel with oxy-acetylene or plasma cutting equipment. Remove scale from material after cutting. A grinder can also be used to prepare bevels.

Create 30 degree angle of bevel on materials in V-groove welding.

4 Double V-Groove Weld

Good for materials thicker than $3/16$ in (5 mm).

S-0662

13-11. Lap Joint

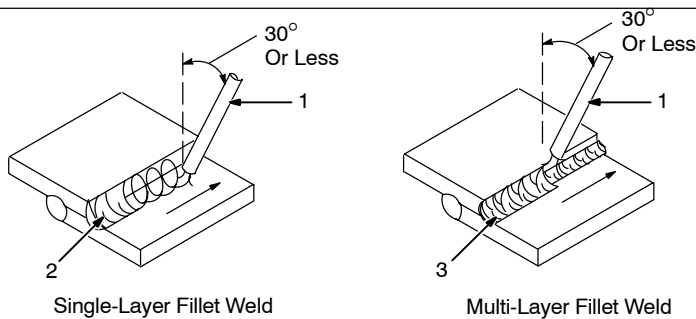

1 Electrode

2 Single-Layer Fillet Weld

Move electrode in circular motion.

3 Multi-Layer Fillet Weld

Weld a second layer when a heavier fillet is needed. Remove slag before making another weld pass. Weld both sides of joint for maximum strength.

S-0063 / S-0064

13-12. Tee Joint

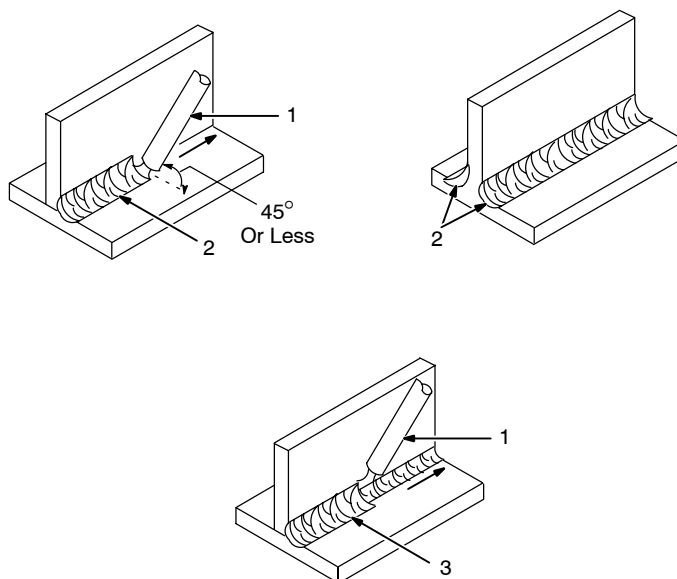

1 Electrode

2 Fillet Weld

Keep arc short and move at definite rate of speed. Hold electrode as shown to provide fusion into the corner. Square edge of the weld surface.

For maximum strength weld both sides of upright section.

3 Multi-Layer Deposits

Weld a second layer when a heavier fillet is needed. Use any of the weaving patterns shown in Section 13-9. Remove slag before making another weld pass.

S-0060 / S-0058-A / S-0061

13-13. Weld Test

1 Vise
2 Weld Joint
3 Hammer

Strike weld joint in direction shown. A good weld bends over but does not break.

S-0057-B

13-14. Troubleshooting – Porosity

Porosity – small cavities or holes resulting from gas pockets in weld metal.

Possible Causes	Corrective Actions
Arc length too long.	Reduce arc length.
Damp electrode.	Use dry electrode.
Workpiece dirty.	Remove all grease, oil, moisture, rust, paint, coatings, slag, and dirt from work surface before welding.

13-15. Troubleshooting – Excessive Spatter

Excessive Spatter – scattering of molten metal particles that cool to solid form near weld bead.

Possible Causes	Corrective Actions
Amperage too high for electrode.	Decrease amperage or select larger electrode.
Arc length too long or voltage too high.	Reduce arc length or voltage.

13-16. Troubleshooting – Incomplete Fusion

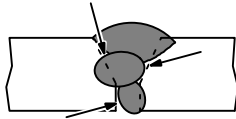
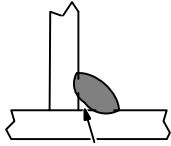

Incomplete Fusion – failure of weld metal to fuse completely with base metal or a preceding weld bead.

Possible Causes	Corrective Actions
Insufficient heat input.	Increase amperage. Select larger electrode and increase amperage.
Improper welding technique.	Place stringer bead in proper location(s) at joint during welding.
	Adjust work angle or widen groove to access bottom during welding.
	Momentarily hold arc on groove side walls when using weaving technique.
	Keep arc on leading edge of weld puddle.
Workpiece dirty.	Remove all grease, oil, moisture, rust, paint, coatings, slag, and dirt from work surface before welding.

13-17. Troubleshooting – Lack Of Penetration

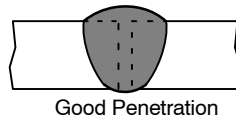
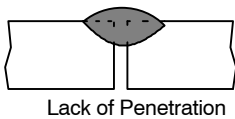

Lack Of Penetration – shallow fusion between weld metal and base metal.

Possible Causes	Corrective Actions
Improper joint preparation.	Material too thick. Joint preparation and design must provide access to bottom of groove.
Improper weld technique.	Keep arc on leading edge of weld puddle.
Insufficient heat input.	Increase amperage. Select larger electrode and increase amperage.
	Reduce travel speed.

13-18. Troubleshooting – Excessive Penetration

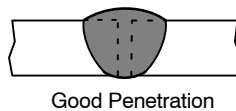
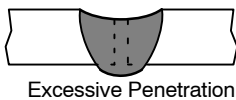

Excessive Penetration – weld metal melting through base metal and hanging underneath weld.

Possible Causes	Corrective Actions
Excessive heat input.	Select lower amperage. Use smaller electrode.
	Increase and/or maintain steady travel speed.

13-19. Troubleshooting – Burn-Through

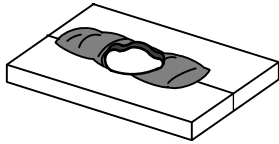

Burn-Through – weld metal melting completely through base metal resulting in holes where no metal remains.

Possible Causes	Corrective Actions
Excessive heat input.	Select lower amperage. Use smaller electrode.
	Increase and/or maintain steady travel speed.

13-20. Troubleshooting – Waviness Of Bead

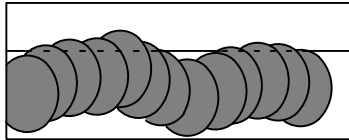

Waviness Of Bead – weld metal that is not parallel and does not cover joint formed by base metal.

Possible Causes	Corrective Actions
Unsteady hand.	Use two hands. Practice technique.

13-21. Troubleshooting – Distortion

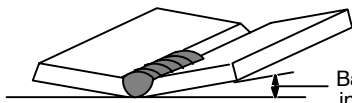

Base metal moves in the direction of the weld bead.

Distortion – contraction of weld metal during welding that forces base metal to move.

Possible Causes	Corrective Actions
Excessive heat input.	Use restraint (clamp) to hold base metal in position.
	Make tack welds along joint before starting welding operation.
	Select lower amperage for electrode.
	Increase travel speed.
	Weld in small segments and allow cooling between welds.

SECTION 14 – MIG WELDING (GMAW) GUIDELINES



14-1. Typical MIG Process Connections Using A Voltage-Sensing Wire Feeder

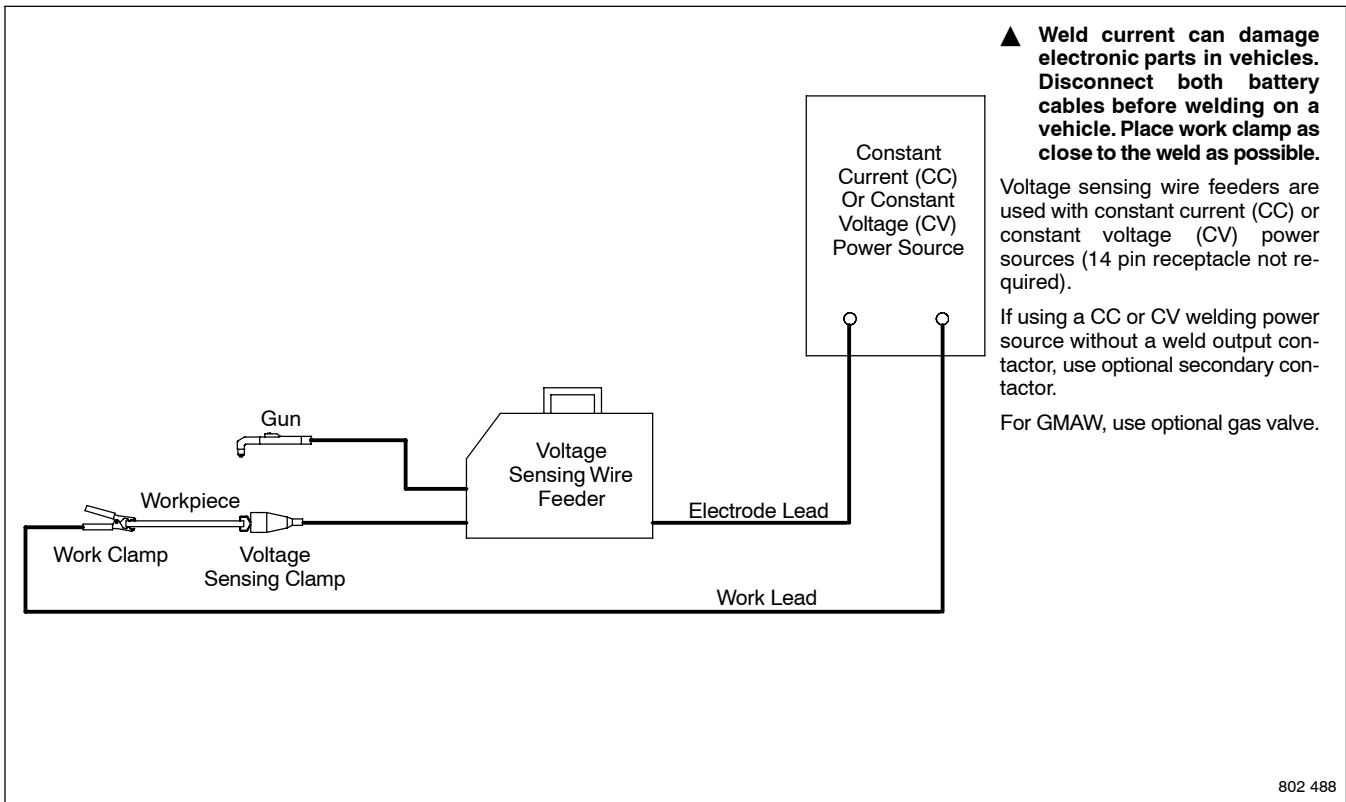

14-2. Typical MIG Process Connections Using A Constant Speed Wire Feeder

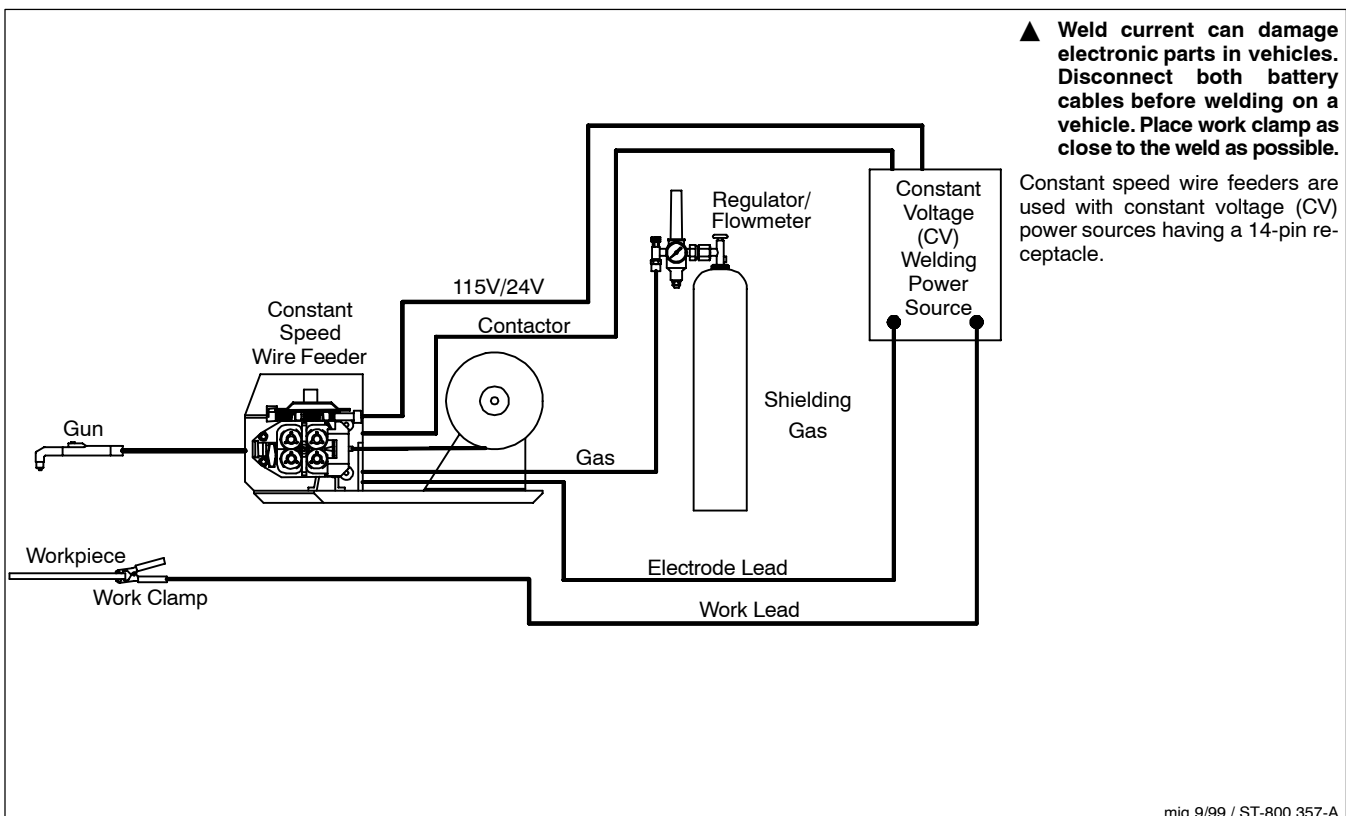

14-3. Typical MIG Process Control Settings

NOTE

These settings are guidelines only. Material and wire type, joint design, fitup, position, shielding gas, etc. affect settings. Test welds to be sure they comply to specifications.

Material thickness determines weld parameters.

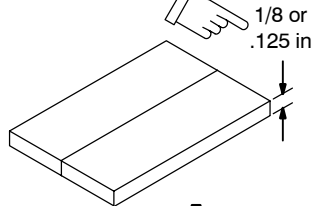

Convert Material Thickness to Amperage (A)

(.001 in = 1 ampere)

.125 in = 125 A

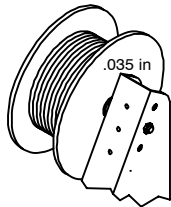

Wire Size	Amperage Range
.030 in	40 – 145 A
.035 in	50 – 180 A
.045 in	75 – 250 A

Select Wire Size

Wire Size	Recommendation	Wire Speed (Approx.)
.030 in	2 in per ampere	2 x 125 A = 250 ipm
.035 in	1.6 in per ampere	1.6 x 125 A = 200 ipm
.045 in	1 in per ampere	1 x 125 A = 125 ipm

Select Wire Speed (Amperage)

125 A based on 1/8 in material thickness

ipm = inch per minute

Low voltage: wire stubs into work
 High voltage: arc is unstable (spatter)
 Set voltage midway between high/low voltage.

Select Voltage

Wire speed (amperage) controls weld penetration (wire speed = burn-off rate)

Voltage controls height and width of weld bead.

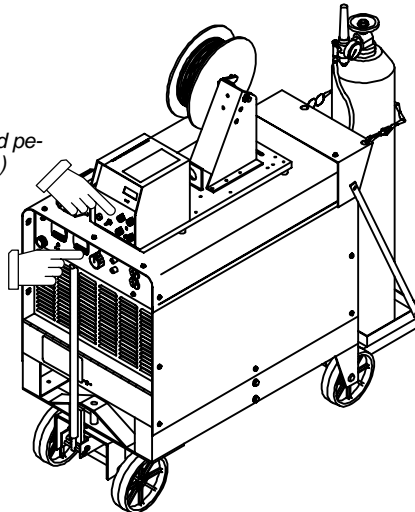

14-4. Holding And Positioning Welding Gun

NOTE

Welding wire is energized when gun trigger is pressed. Before lowering helmet and pressing trigger, be sure wire is no more than 1/2 in (13 mm) past end of nozzle, and tip of wire is positioned correctly on seam.

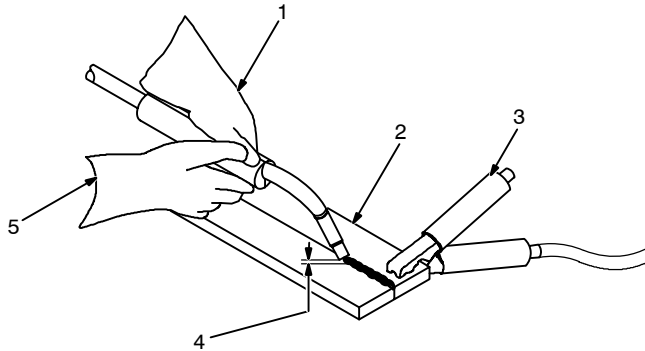

- 1 Hold Gun and Control Gun Trigger
- 2 Workpiece
- 3 Work Clamp
- 4 Electrode Extension (Stickout) 1/4 to 1/2 in (6 To 13 mm)
- 5 Cradle Gun and Rest Hand on Workpiece

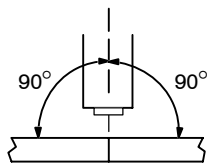

End View Of Work Angle

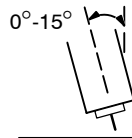

Side View Of Gun Angle

GROOVE WELDS

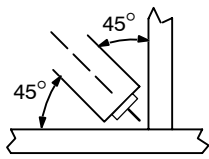

End View Of Work Angle

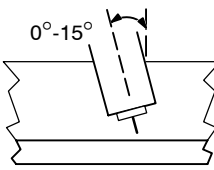

Side View Of Gun Angle

FILLET WELDS

S-0421-A

14-5. Conditions That Affect Weld Bead Shape

NOTE

Weld bead shape depends on gun angle, direction of travel, electrode extension (stickout), travel speed, thickness of base metal, wire feed speed (weld current), and voltage.

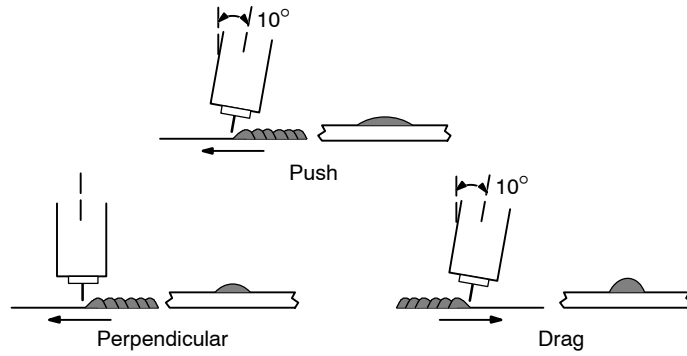

GUN ANGLES AND WELD BEAD PROFILES

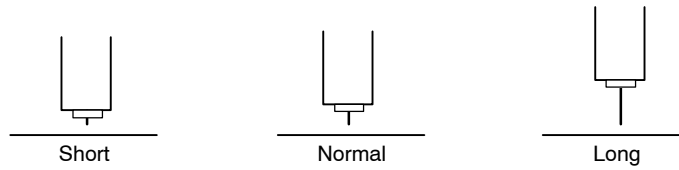

ELECTRODE EXTENSIONS (STICKOUT)

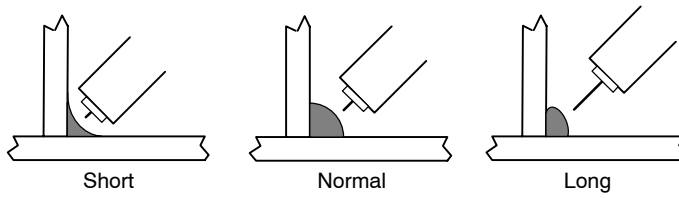

FILLET WELD ELECTRODE EXTENSIONS (STICKOUT)

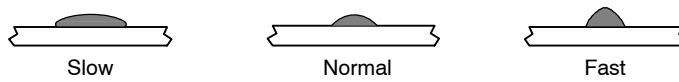

GUN TRAVEL SPEED

S-0634

14-6. Gun Movement During Welding

NOTE

Normally, a single stringer bead is satisfactory for most narrow groove weld joints; however, for wide groove weld joints or bridging across gaps, a weave bead or multiple stringer beads works better.

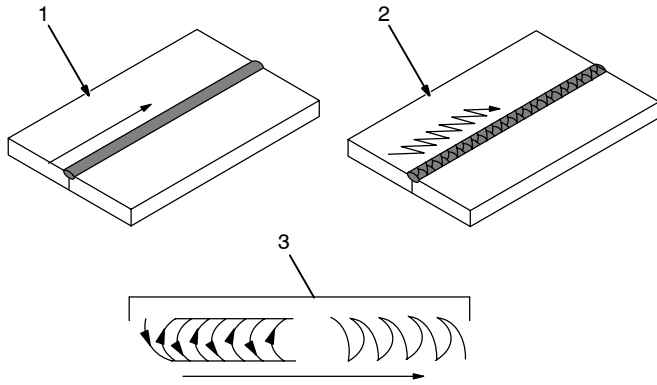

- 1 Stringer Bead – Steady Movement Along Seam
- 2 Weave Bead – Side To Side Movement Along Seam
- 3 Weave Patterns

Use weave patterns to cover a wide area in one pass of the electrode.

S-0054-A

14-7. Poor Weld Bead Characteristics

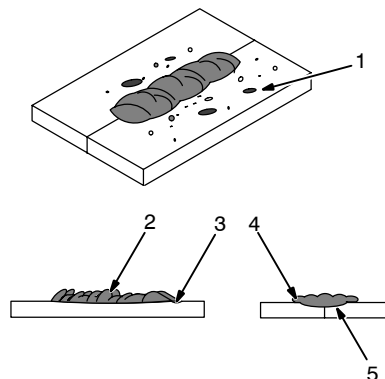

- 1 Large Spatter Deposits
- 2 Rough, Uneven Bead
- 3 Slight Crater During Welding
- 4 Bad Overlap
- 5 Poor Penetration

S-0053-A

14-8. Good Weld Bead Characteristics

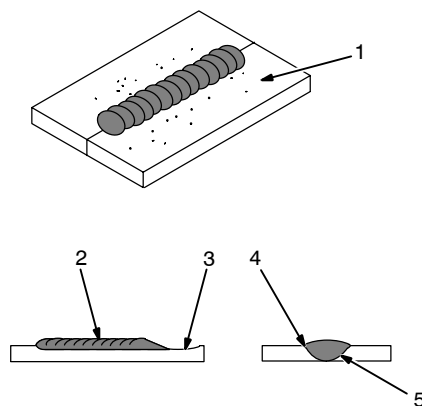

- 1 Fine Spatter
- 2 Uniform Bead
- 3 Moderate Crater During Welding

Weld a new bead or layer for each 1/8 in (3.2 mm) thickness in metals being welded.

- 4 No Overlap
- 5 Good Penetration into Base Metal

S-0052-B

14-9. Troubleshooting – Excessive Spatter

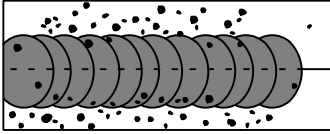

Excessive Spatter – scattering of molten metal particles that cool to solid form near weld bead.

S-0636

Possible Causes	Corrective Actions
Wire feed speed too high.	Select lower wire feed speed.
Voltage too high.	Select lower voltage range.
Electrode extension (stickout) too long.	Use shorter electrode extension (stickout).
Workpiece dirty.	Remove all grease, oil, moisture, rust, paint, undercoating, and dirt from work surface before welding.
Insufficient shielding gas at welding arc.	Increase flow of shielding gas at regulator/flowmeter and/or prevent drafts near welding arc.
Dirty welding wire.	Use clean, dry welding wire.
	Eliminate pickup of oil or lubricant on welding wire from feeder or liner.

14-10. Troubleshooting – Porosity

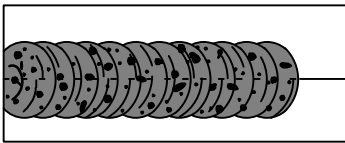

Porosity – small cavities or holes resulting from gas pockets in weld metal.

S-0635

Possible Causes	Corrective Actions
Insufficient shielding gas at welding arc.	Increase flow of shielding gas at regulator/flowmeter and/or prevent drafts near welding arc.
	Remove spatter from gun nozzle.
	Check gas hoses for leaks.
	Place nozzle 1/4 to 1/2 in (6-13 mm) from workpiece.
	Hold gun near bead at end of weld until molten metal solidifies.
Wrong gas.	Use welding grade shielding gas; change to different gas.
Dirty welding wire.	Use clean, dry welding wire.
	Eliminate pick up of oil or lubricant on welding wire from feeder or liner.
Workpiece dirty.	Remove all grease, oil, moisture, rust, paint, coatings, and dirt from work surface before welding.
	Use a more highly deoxidizing welding wire (contact supplier).
Welding wire extends too far out of nozzle.	Be sure welding wire extends not more than 1/2 in (13 mm) beyond nozzle.

14-11. Troubleshooting – Excessive Penetration

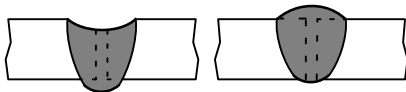

Excessive Penetration Good Penetration

Excessive Penetration – weld metal melting through base metal and hanging underneath weld.

S-0639

Possible Causes	Corrective Actions
Excessive heat input.	Select lower voltage range and reduce wire feed speed.
	Increase travel speed.

14-12. Troubleshooting – Lack Of Penetration

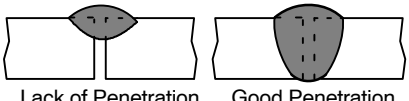
 <p>Lack of Penetration Good Penetration</p>		<p>Lack Of Penetration – shallow fusion between weld metal and base metal.</p>	S-0638
Possible Causes	Corrective Actions		
Improper joint preparation.	Material too thick. Joint preparation and design must provide access to bottom of groove while maintaining proper welding wire extension and arc characteristics.		
Improper weld technique.	Maintain normal gun angle of 0 to 15 degrees to achieve maximum penetration.		
	Keep arc on leading edge of weld puddle.		
	Be sure welding wire extends not more than 1/2 in (13 mm) beyond nozzle.		
Insufficient heat input.	Select higher wire feed speed and/or select higher voltage range.		
	Reduce travel speed.		

14-13. Troubleshooting – Incomplete Fusion

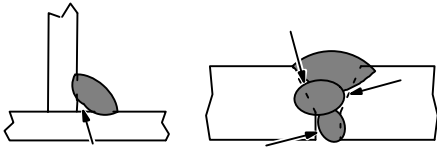
		<p>Incomplete Fusion – failure of weld metal to fuse completely with base metal or a preceding weld bead.</p>	S-0637
Possible Causes	Corrective Actions		
Workpiece dirty.	Remove all grease, oil, moisture, rust, paint, undercoating, and dirt from work surface before welding.		
Insufficient heat input.	Select higher voltage range and/or adjust wire feed speed.		
Improper welding technique.	Place stringer bead in proper location(s) at joint during welding.		
	Adjust work angle or widen groove to access bottom during welding.		
	Momentarily hold arc on groove side walls when using weaving technique.		
	Keep arc on leading edge of weld puddle.		
	Use correct gun angle of 0 to 15 degrees.		

14-14. Troubleshooting – Burn-Through

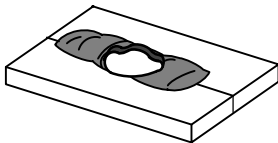
		<p>Burn-Through – weld metal melting completely through base metal resulting in holes where no metal remains.</p>	S-0640
Possible Causes	Corrective Actions		
Excessive heat input.	Select lower voltage range and reduce wire feed speed.		
	Increase and/or maintain steady travel speed.		

14-15. Troubleshooting – Waviness Of Bead

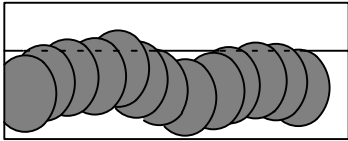

Waviness Of Bead – weld metal that is not parallel and does not cover joint formed by base metal.

S-0641

Possible Causes	Corrective Actions
Welding wire extends too far out of nozzle.	Be sure welding wire extends not more than 1/2 in (13 mm) beyond nozzle.
Unsteady hand.	Support hand on solid surface or use two hands.

14-16. Troubleshooting – Distortion

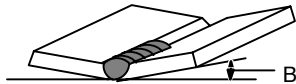

Base metal moves in the direction of the weld bead.

Distortion – contraction of weld metal during welding that forces base metal to move.

S-0642

Possible Causes	Corrective Actions
Excessive heat input.	Use restraint (clamp) to hold base metal in position.
	Make tack welds along joint before starting welding operation.
	Select lower voltage range and/or reduce wire feed speed.
	Increase travel speed.
	Weld in small segments and allow cooling between welds.

14-17. Common MIG Shielding Gases

This is a general chart for common gases and where they are used. Many different combinations (mixtures) of shielding gases have been developed over the years. The most commonly used shielding gases are listed in the following table.

Gas	Application					
	Spray Arc Steel	Short Circuiting Steel	Spray Arc Stainless Steel	Short Circuiting Stainless Steel	Spray Arc Aluminum	Short Circuiting Aluminum
Argon					All Positions ⁵	All Positions
Argon + 1% O₂	Flat & Horizontal ⁵ Fillet		Flat & Horizontal ⁵ Fillet			
Argon + 2% O₂	Flat & Horizontal ⁵ Fillet		Flat & Horizontal ⁵ Fillet			
Argon + 5% O₂	Flat & Horizontal ⁵ Fillet					
Argon + 8% CO₂	Flat & Horizontal ⁵ Fillet	All Positions				
Argon + 25% CO₂	Flat & Horizontal ¹ Fillet	All Positions		All Positions ³		
Argon + 50% CO₂		All Positions				
CO₂	Flat & Horizontal ¹ Fillet	All Positions				
Helium					All Positions ²	
Argon + Helium					All Positions ²	
Tri-Mix⁴				All Positions		

- 1 Globular Transfer
- 2 Heavy Thicknesses
- 3 Single Pass Welding Only
- 4 90% HE + 7-1/2% AR + 2-1/2% CO₂
- 5 Also for GMAW-P, All Positions

SECTION 15 – PARTS LIST

 Hardware is common and not available unless listed.

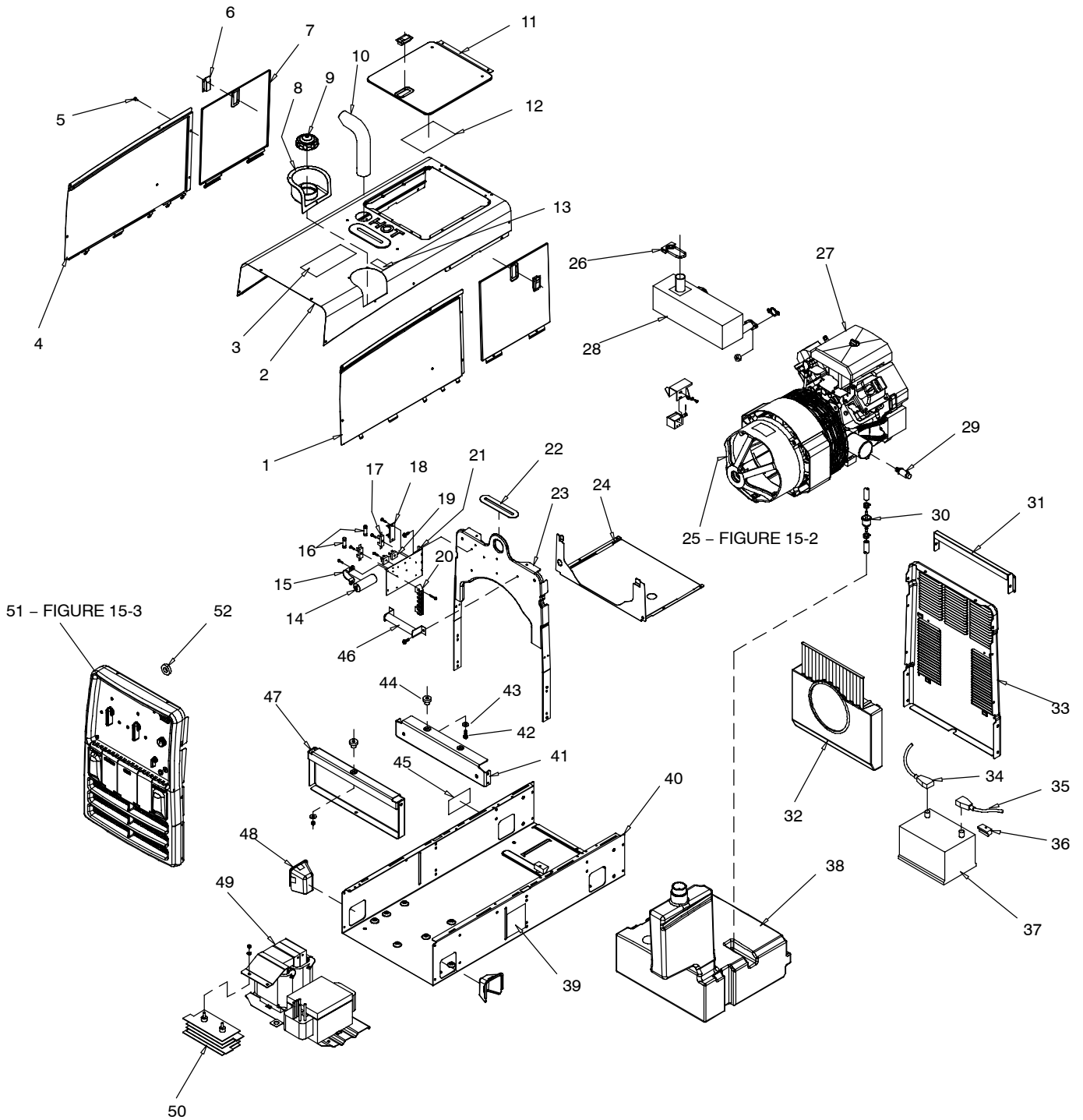

Figure 15-1. Main Assembly (Kohler Engine Shown)

Item No.	Dia. Mkgs.	Part No.	Description	Quantity
Figure 15-1. Main Assembly				
1		+211366	Panel, Side Rh	1
2		+211367	Cover, Top	1
3		200795	Label, Warning General Precautionary Csa	1
4		+211365	Panel, Side Lh	1
5		217395	Bumper, Rubber Press-in	10
6		211370	Latch, Door	3
7		+211368	Door, Access Engine Side	2
		220371	Seal, Rubber W/Adhesive .370 X .750 X 14.500	2
8		211398	Grommet, Plastic Neck Filler Fuel	1
9		166608	Cap, Tank Screw-on W/Vent	1
10		211527	Pipe, Exhaust Elbow	1
11		+211369	Door Assy, Access Engine Top	1
12		215939	Label, Engine Maintenance Robin & Kohler	1
13		219329	Label, Use Gasoline Fuel Only	1
14	C1	210639	Capacitor, Elctlt 1500 Uf 75 Vdc Can 1.40 Dia	1
15		177136	Clamp, Capacitor 1.375 Dia	1
16	F1, F2	169296	Fuse, Mintr Gl 25. Amp 125 Volt	2
17		172731	Holder, Fuse Mintr .250 X 1.250 Clip Anti-pivot	2
18	D4	135184	Diode Board	1
19	SR2, SR3	035704	Rectifier, Integ Bridge 40. Amp 800 Volt	2
20	1T	172661	Block, Stud Connection 6 Position	1
		173734	Link, Jumper	1
21		211376	Bracket, Mtg Component	1
22		205734	Seal, Weather Lift Eye	1
23		211360	Upright, Base	1
24		211359	Cover, Tank Fuel	1
25		Figure15-2	Generator Assembly	1
26		209057	Clamp, Muffler 1.625 Dia U Pld	1
27		211401	Engine, Gas Elec Start Kohler (Includes)	1
28		211402	Muffler, Exhaust Engine	1
29		165271	Valve, Oil Drain 3/8-18 Nptf	1
30		*215984	Filter, Fuel In-line .250	1
	F6	*021718	Fuse, Mintr Gl 30. Amp 32 Volt	1
		*180096	Tune-up & Filter Kit, Kohler (Includes)	1
		067272	Air Filter Element, Kohler	1
		066698	Oil Filter, Kohler	1
		215985	Filter, Fuel w/Clamps & 1/4 in Fuel Line	1
		067007	Spark Plug	2
		*067273	Air Filter Wrapper	1
27		211403	Engine, Gas Elect Start Robin (Includes)	1
28		211404	Muffler, Exhaust Engine	1
29		165271	Valve, Oil Drain 3/8-18 Nptf	1
30		*066113	Filter, Fuel In-line .250	1
	F6	*021718	Fuse, Mintr Gl 30. Amp 32 Volt	1
		*199062	Tune-up & Filter Kit, Robin (Includes)	1
		198755	Element, Air Filter	1
		198754	Filter, Oil	1
		215985	Filter, Fuel w/Clamps & 1/4 Fuel Line	1
		198777	Spark Plug	1
31		217067	Stiffener, Rear Panel	1
32		213952	Baffle, Engine Air Assy	1
33		+211364	Panel, Rear	1
34		217848	Cable, Bat Neg 15.000 No 4 Awg W/Clamp & .343 Rng	1
34		217847	Cable, Bat Neg 8.000 6ga W/.250 Rng & .375 Rng	1
35		219811	Cable, Bat Pos 25.000 No 4 Awg W/Clamp & .312 Rng	1
36		182935	Hold Down, Battery	2
37	BATT	168037	Battery, Stor 12 Volt 430 Crk 75 Rsv Gp 58 Dry	1

Item No.	Dia. Mkgs.	Part No.	Description	Quantity
Figure 15-1. Main Assembly (Continued)				
... 38		199052	Tank, Fuel 12.0 Gal	1
		214843	Hose, Sae .250 Id X .500 Od X 10.250 Kohler	1
		161860	Hose, Sae .250 Id X .500 X 8.000 Robin	1
... 39		217015	Label, Warning Do Not Weld On Base/Fuel Level	2
... 40		+211356	Pan, Base	1
... 41		211210	Bracket, Mtg Engine Kohler	1
... 41		211213	Bracket, Mtg Engine Robin	1
... 42		127595	Screw, 375-16x2.50 Hex Hd-pln Gr5 Pld	2
... 43		010954	Washer, Flat .406idx1.250odx.125t Stl Pld	3
... 44		214556	Mount, Vibration	3
		167788	Nut, 375-16 .56hex .34h Stl Pld Sem Cone Wshr.88d	3
... 45		219654	Label, Warning Battery Explosion Can Blind	1
... 46	R2	200518	Resistor, WW Fxd 225 W 3.15 Ohm W/2.85 Ta	1
... 47		211358	Bracket, Mtg Generator	1
... 48		211355	Cover, Base	2
... 49	DC-Z	219012	Reactor, Stabilizer	1
... 50	SR1	192682	Rectifier, Si 1 Ph, 240 Amp, 400 Piv 60% Duty Cycle	1
... 51		Figure15-3	Front Panel Assembly	1
... 52	CT1	218664	Xfmr, Current Sensing	1
		147551	Tool, Puller Rotor (Service Item)	1
		177126	Tool, Puller Rotor (Service Item)	1
		167640	Housing Plug Pins+Skts, (Service Kit)	1
		219008	Kit, Label Robin	1
		218198	Kit, Label Kohler	1

+When ordering a component originally displaying a precautionary label, the label should also be ordered. Labels available separately or as part of label kit 219008 (Robin) or 218198 (Kohler).

◆ Optional

* Recommended Spare Parts.

To maintain the factory original performance of your equipment, use only Manufacturer's Suggested Replacement Parts. Model and serial number required when ordering parts from your local distributor.

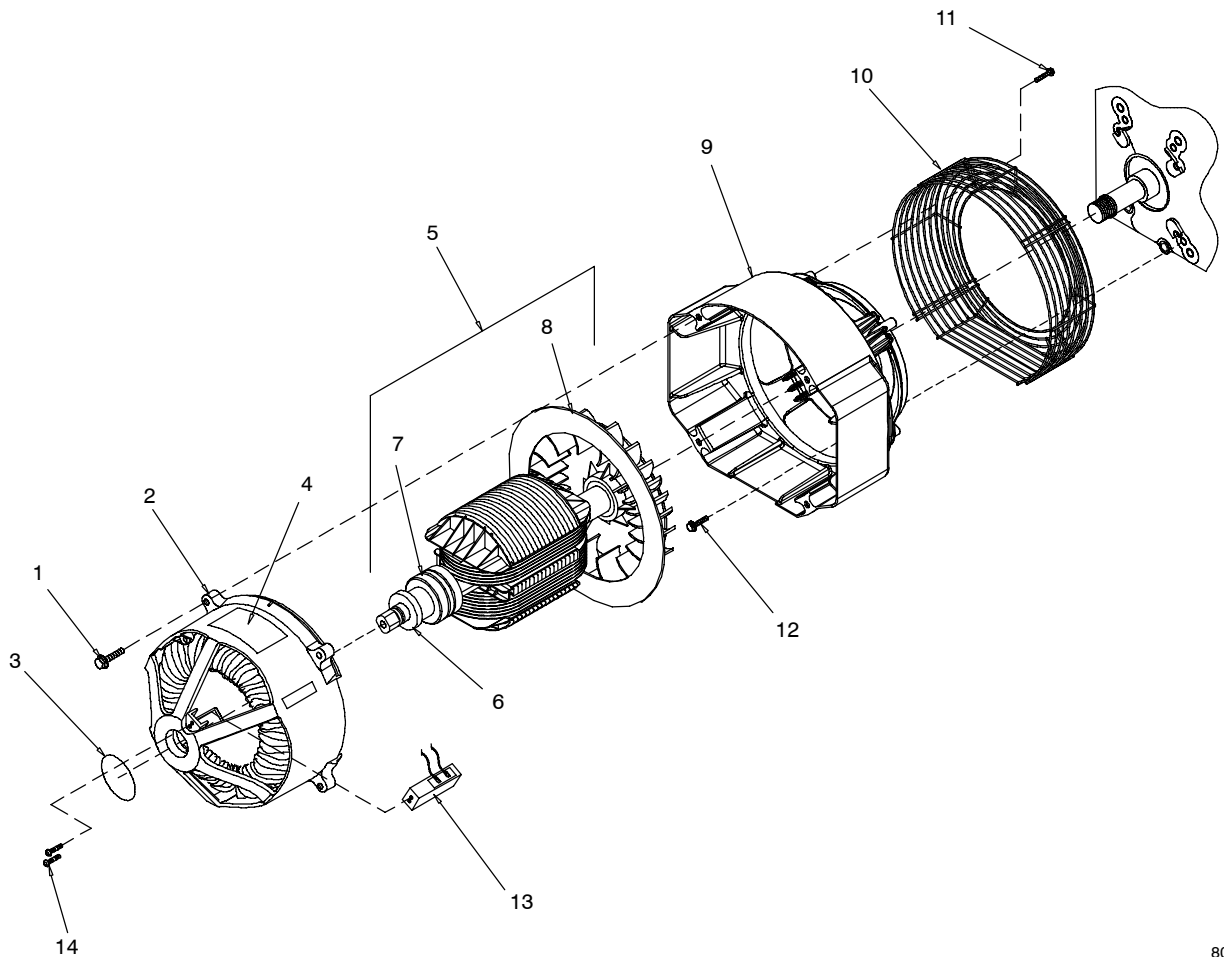

803 882

Figure 15-2. Generator

Item No.	Part No.	Description	Quantity
Figure15-2. Generator (Figure 15-1 Item 25)			
...	1	142156 .. Screw, 375-16x1.75 Hexwhd.81d Gr8 Pld	4
...	2	+219010 .. Generator Assy, Front	1
...	3	183419 O-Ring 1.984 Id X .139 cs 70 Duro Viton	1
...	4	013367 .. Label, Warning Moving Parts Can Cause Serious Etc	1
...	5	217681 .. Rotor, Generator (Includes)	1
...	6	181143 Bearing, Ball Rdl Sgl Row .984 X 2.047 X .591	1
...	7	181135 Ring, Collector Rotor	1
...	8	216444 Fan, Rotor Gen	1
...	9	211357 .. Housing, Generator Rear	1
...	10	213979 .. Guard, Fan	1
...	11	602224 .. Screw, 250-20x .75 Hexwhd.50d Stl Pld Slffmg Tap-rw	4
...	12	186083 .. Screw, 437-14x1.75 Hexwhd.93d Gr8 Pld	4
...	13	205725 .. Brushholder Assy, Generator	1
...	14	136343 .. Screw, K50x 20 Pan Hd-phl Stl Pld Pt Thread Forming	2

+When ordering a component originally displaying a precautionary label, the label should also be ordered. Labels available separately or as part of label kit 219008 (Robin) or 218198 (Kohler).

To maintain the factory original performance of your equipment, use only Manufacturer's Suggested Replacement Parts. Model and serial number required when ordering parts from your local distributor.

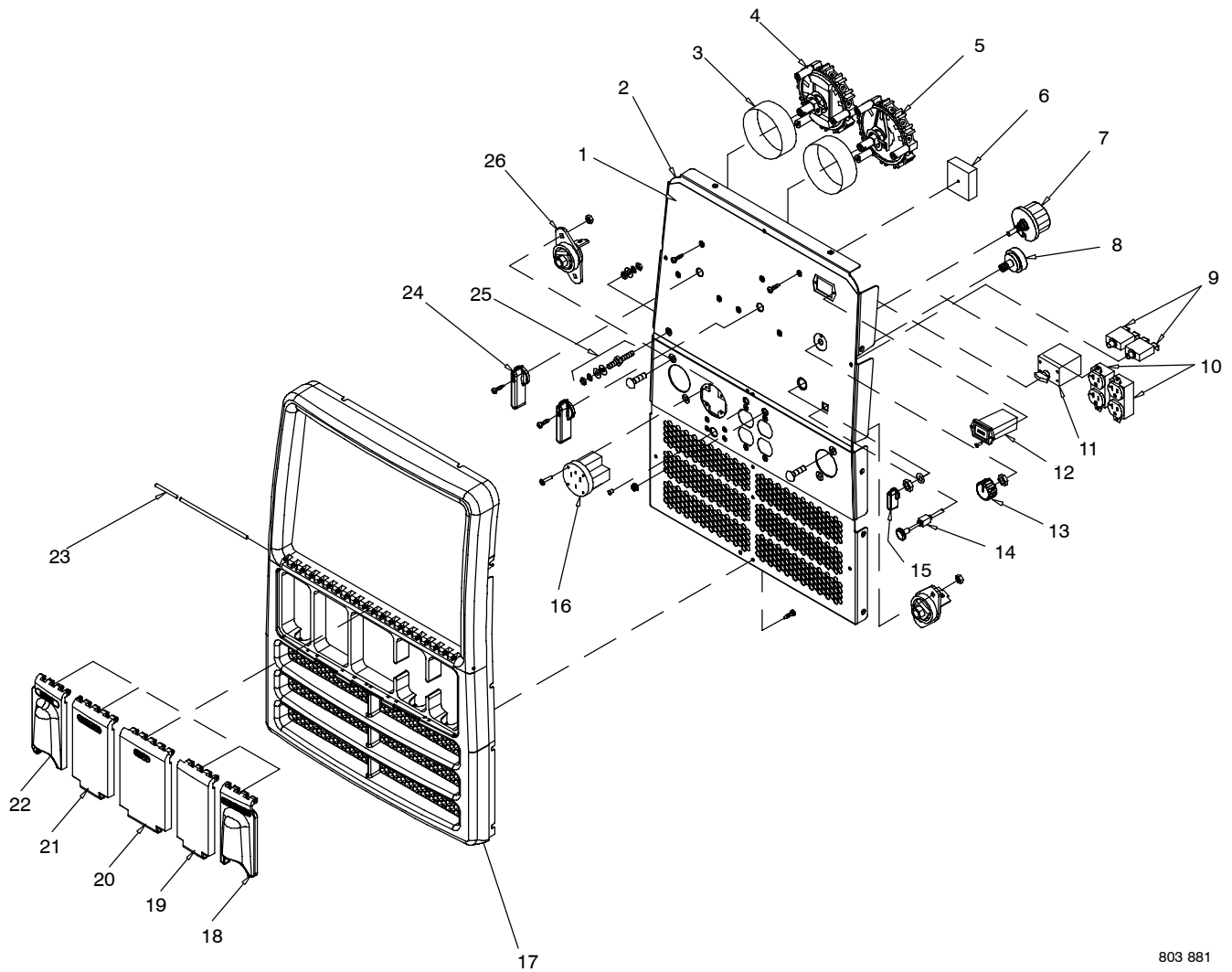

803 881

Figure 15-3. Panel, Front w/Components

Item No.	Dia. Mkgs.	Part No.	Description	Quantity
----------	------------	----------	-------------	----------

Figure 15-3. Panel, Front w/Components (Figure 15-1 Item 51)

...	1		Nameplate (Order By Model And Serial No.)	1
...	2	211361	Panel, Front	1
...	3	186058	Cover, Dust	2
...	4	S1 219530	Switch, Polarity 5 Position W/Leads & Jumpers	1
...	5	S3 219757	Switch, Range 6 Position	1
...	6	PC1 201936	Module, Pull To Idle 5 Pin	1
...	7	R1 207177	Rheostat, WW 150. W 14. Ohm Frict Term	1
...	8	S2 217680	Switch, Ignition 4 Position W/Out Handle	1
...	9	CB2, CB3 093996	Circuit Breaker, Man Reset 1p 20a 250vac Frict	2
...	10	RC2, RC3 141432	Rcpt, Str Dx Grd 2p3w 20a 125v *5-20r	2
...	11	CB1 200929	Circuit Breaker, Man Reset 2p 50a 240vac Screw-90	1
...	12	HM 145247	Meter, Hour 12-24vdc 1.25 X 2.12 Rect	1
...	13	207077	Knob, Pointer 1.625 Dia. Push On	1
...	14	217887	Control, Push/Pull Snap-in 45.000 W/1.750 Extension Kohler	1
...	14	217888	Control, Push/Pull Snap-in 48.000 w/1.750 Extension Robin	1
...	15	207073	Lever, Ignition Switch	1
...	16	RC1 182954	Rcpt, Str 3p4w 50a 125/250v Flush Mtg *14-50	1

Item No.	Dia. Mkgs.	Part No.	Description	Quantity
Figure 15-3. Panel, Front w/Components (Continued)				
.....		217346	.. Bezel Assy (Includes)	1
... 17		211416 Bezel	1
... 18		216776 Cover, Output Stud Electrode	1
... 19		213637 Cover, Output Stud	1
... 20		216773 Cover, Receptacle Duplex 120v	1
... 21		216774 Cover, Receptacle Full Kva 120/240v	1
... 22		216772 Cover, Output Stud Work	1
... 23		211405 Pin, Hinge	1
... 24		207074	.. Handle, Switch	2
... 25	GRD	197203	.. Grounding Stud Assy, Brass	1
... 26	ELECT, WORK	099255	.. Terminal, Pwr Output Neutral	2

◆ Optional

To maintain the factory original performance of your equipment, use only Manufacturer's Suggested Replacement Parts. Model and serial number required when ordering parts from your local distributor.

Note  *Some wiring harness components (switches, relays, circuit breakers) are also referenced elsewhere in this parts list. Purchase components separately or as part of the associated wiring harness.*

Item No.	Dia. Mkgs.	Part No.	Description	Quantity
Wiring Harnesses				
.....		219016	.. Harness, Wrg Unit (Includes)	1
.....	PLG8	177859 Conn, Body 5 Terminal	1
.....	RC4/PLG4	116045 Conn, Rect Univ 084 6p/S 3row Rcpt Cable/Pane (Service Kit)	1
.....	RC6/PLG6	136810 Conn, Rect Univ 084 4p/S 1row Plug Cable Lkg (Service Kit)	1

TRUE BLUE[®]

WARRANTY

Effective January 1, 2004

(Equipment with a serial number preface of "LE" or newer)

This limited warranty supersedes all previous Miller warranties and is exclusive with no other guarantees or warranties expressed or implied.

Warranty Questions?

Call
1-800-4-A-MILLER
for your local
Miller distributor.

Your distributor also gives
you ...

Service

You always get the fast,
reliable response you
need. Most replacement
parts can be in your
hands in 24 hours.

Support

Need fast answers to the
tough welding questions?
Contact your distributor.
The expertise of the
distributor and Miller is
there to help you, every
step of the way.

LIMITED WARRANTY - Subject to the terms and conditions below, Miller Electric Mfg. Co., Appleton, Wisconsin, warrants to its original retail purchaser that new Miller equipment sold after the effective date of this limited warranty is free of defects in material and workmanship at the time it is shipped by Miller. THIS WARRANTY IS EXPRESSLY IN LIEU OF ALL OTHER WARRANTIES, EXPRESS OR IMPLIED, INCLUDING THE WARRANTIES OF MERCHANTABILITY AND FITNESS.

Within the warranty periods listed below, Miller will repair or replace any warranted parts or components that fail due to such defects in material or workmanship. Miller must be notified in writing within thirty (30) days of such defect or failure, at which time Miller will provide instructions on the warranty claim procedures to be followed.

Miller shall honor warranty claims on warranted equipment listed below in the event of such a failure within the warranty time periods. All warranty time periods start on the date that the equipment was delivered to the original retail purchaser, or one year after the equipment is sent to a North American distributor or eighteen months after the equipment is sent to an International distributor.

- 5 Years Parts — 3 Years Labor
 - * Original main power rectifiers
 - * Inverters (input and output rectifiers only)
- 3 Years — Parts and Labor
 - * Transformer/Rectifier Power Sources
 - * Plasma Arc Cutting Power Sources
 - * Semi-Automatic and Automatic Wire Feeders
 - * Inverter Power Sources (Unless Otherwise Stated)
 - * Water Coolant Systems (Integrated)
 - * Intelligig
 - * Maxstar 150
 - * Engine Driven Welding Generators
(NOTE: Engines are warranted separately by the engine manufacturer.)
- 1 Year — Parts and Labor Unless Specified
 - * DS-2 Wire Feeder
 - * Motor Driven Guns (w/exception of Spoolmate Spoolguns)
 - * Process Controllers
 - * Positioners and Controllers
 - * Automatic Motion Devices
 - * RFCS Foot Controls
 - * Induction Heating Power Sources and Coolers
 - * Water Coolant Systems (Non-Integrated)
 - * Flowgauge and Flowmeter Regulators (No Labor)
 - * HF Units
 - * Grids
 - * Maxstar 85, 140
 - * Spot Welders
 - * Load Banks
 - * Arc Stud Power Sources & Arc Stud Guns
 - * Racks
 - * Running Gear/Trailers
 - * Plasma Cutting Torches (except APT & SAF Models)
 - * Field Options
(NOTE: Field options are covered under True Blue[®] for the remaining warranty period of the product they are installed in, or for a minimum of one year — whichever is greater.)
- 6 Months — Batteries
- 90 Days — Parts
 - * MIG Guns/TIG Torches

- * Induction Heating Coils and Blankets
- * APT & SAF Model Plasma Cutting Torches
- * Remote Controls
- * Accessory Kits
- * Replacement Parts (No labor)
- * Spoolmate Spoolguns
- * Canvas Covers

Miller's True Blue[®] Limited Warranty shall not apply to:

- Consumable components; such as contact tips, cutting nozzles, contactors, brushes, slip rings, relays or parts that fail due to normal wear. (Exception: brushes, slip rings, and relays are covered on Bobcat, Trailblazer, and Legend models.)**
- Items furnished by Miller, but manufactured by others, such as engines or trade accessories. These items are covered by the manufacturer's warranty, if any.
- Equipment that has been modified by any party other than Miller, or equipment that has been improperly installed, improperly operated or misused based upon industry standards, or equipment which has not had reasonable and necessary maintenance, or equipment which has been used for operation outside of the specifications for the equipment.

MILLER PRODUCTS ARE INTENDED FOR PURCHASE AND USE BY COMMERCIAL/INDUSTRIAL USERS AND PERSONS TRAINED AND EXPERIENCED IN THE USE AND MAINTENANCE OF WELDING EQUIPMENT.

In the event of a warranty claim covered by this warranty, the exclusive remedies shall be, at Miller's option: (1) repair; or (2) replacement; or, where authorized in writing by Miller in appropriate cases, (3) the reasonable cost of repair or replacement at an authorized Miller service station; or (4) payment of or credit for the purchase price (less reasonable depreciation based upon actual use) upon return of the goods at customer's risk and expense. Miller's option of repair or replacement will be F.O.B., Factory at Appleton, Wisconsin, or F.O.B. at a Miller authorized service facility as determined by Miller. Therefore no compensation or reimbursement for transportation costs of any kind will be allowed.

TO THE EXTENT PERMITTED BY LAW, THE REMEDIES PROVIDED HEREIN ARE THE SOLE AND EXCLUSIVE REMEDIES. IN NO EVENT SHALL MILLER BE LIABLE FOR DIRECT, INDIRECT, SPECIAL, INCIDENTAL OR CONSEQUENTIAL DAMAGES (INCLUDING LOSS OF PROFIT), WHETHER BASED ON CONTRACT, TORT OR ANY OTHER LEGAL THEORY.

ANY EXPRESS WARRANTY NOT PROVIDED HEREIN AND ANY IMPLIED WARRANTY, GUARANTY OR REPRESENTATION AS TO PERFORMANCE, AND ANY REMEDY FOR BREACH OF CONTRACT TORT OR ANY OTHER LEGAL THEORY WHICH, BUT FOR THIS PROVISION, MIGHT ARISE BY IMPLICATION, OPERATION OF LAW, CUSTOM OF TRADE OR COURSE OF DEALING, INCLUDING ANY IMPLIED WARRANTY OF MERCHANTABILITY OR FITNESS FOR PARTICULAR PURPOSE, WITH RESPECT TO ANY AND ALL EQUIPMENT FURNISHED BY MILLER IS EXCLUDED AND DISCLAIMED BY MILLER.

Some states in the U.S.A. do not allow limitations of how long an implied warranty lasts, or the exclusion of incidental, indirect, special or consequential damages, so the above limitation or exclusion may not apply to you. This warranty provides specific legal rights, and other rights may be available, but may vary from state to state.

In Canada, legislation in some provinces provides for certain additional warranties or remedies other than as stated herein, and to the extent that they may not be waived, the limitations and exclusions set out above may not apply. This Limited Warranty provides specific legal rights, and other rights may be available, but may vary from province to province.





Owner's Record

Please complete and retain with your personal records.

Model Name

Serial/Style Number

Purchase Date

(Date which equipment was delivered to original customer.)

Distributor

Address

City

State

Zip



For Service

Call 1-800-4-A-Miller or see our website at www.MillerWelds.com to locate a DISTRIBUTOR or SERVICE AGENCY near you.

Always provide Model Name and Serial/Style Number.

Contact your Distributor for:

Welding Supplies and Consumables

Options and Accessories

Personal Safety Equipment

Service and Repair

Replacement Parts

Training (Schools, Videos, Books)

Technical Manuals (Servicing Information and Parts)

Circuit Diagrams

Welding Process Handbooks

Contact the Delivering Carrier to:

File a claim for loss or damage during shipment.

For assistance in filing or settling claims, contact your distributor and/or equipment manufacturer's Transportation Department.

Miller Electric Mfg. Co.

An Illinois Tool Works Company
1635 West Spencer Street
Appleton, WI 54914 USA

International Headquarters—USA

USA Phone: 920-735-4505 Auto-Attended
USA & Canada FAX: 920-735-4134
International FAX: 920-735-4125

European Headquarters – United Kingdom

Phone: 44 (0) 1204-593493
FAX: 44 (0) 1204-598066

www.MillerWelds.com

