



OM-291052C

2024-06

Processes



Multiprocess Welding

Description



Arc Welding Power Source

# XMT<sup>®</sup> 650

## ArcReach Polarity Reversing 380V/460V

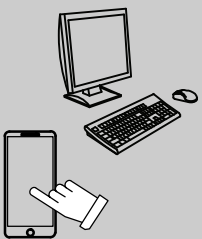
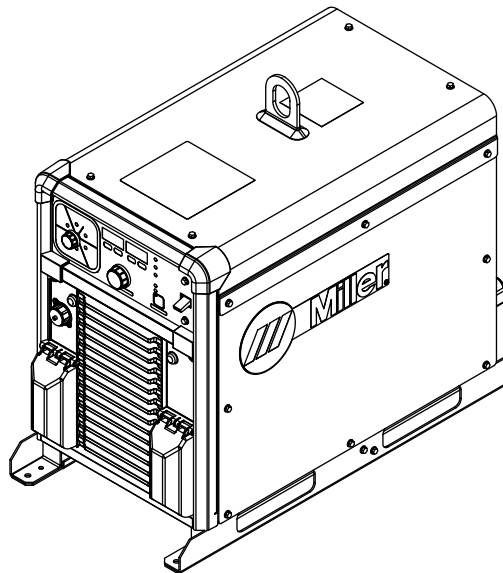

For product information,  
Owner's Manual translations,  
and more, visit

[www.MillerWelds.com](http://www.MillerWelds.com)

# OWNER'S MANUAL

# From Miller to You

---

*Thank you and congratulations* on choosing Miller. Now you can get the job done and get it done right. We know you don't have time to do it any other way.

That's why when Niels Miller first started building arc welders in 1929, he made sure his products offered long-lasting value and superior quality. Like you, his customers couldn't afford anything less. Miller products had to be more than the best they could be. They had to be the best you could buy.

Today, the people that build and sell Miller products continue the tradition. They're just as committed to providing equipment and service that meets the high standards of quality and value established in 1929.

This Owner's Manual is designed to help you get the most out of your Miller products. Please take time to read the Safety Precautions. They will help you protect yourself against potential hazards on the worksite. We've made installation and operation quick and easy. With Miller, you can count on years of reliable service with proper maintenance. And if for some reason the unit needs repair, there's a Troubleshooting section that will help you figure out what the problem is, and our extensive service network is there to help fix the problem. Warranty and maintenance information for your particular model are also provided.

Miller Electric manufactures a full line of welders and welding-related equipment. For information on other quality Miller products, contact your local Miller distributor to receive the latest full line catalog or individual specification sheets. **To locate your nearest distributor or service agency call**

**1-800-4-A-Miller, or visit us at [www.MillerWelds.com](http://www.MillerWelds.com) on the web.**



Working as hard as you do – every power source from Miller is backed by the most hassle-free warranty in the business.



ISO 9001  
Quality

Miller is the first welding equipment manufacturer in the U.S.A. to be registered to the ISO 9001 Quality System Standard.



# TABLE OF CONTENTS

<b>SECTION 1 – SAFETY PRECAUTIONS – READ BEFORE USING</b>	<b>1</b>
1-1 Symbol Usage	1
1-2 Arc Welding Hazards	1
1-3 Additional Hazards For Installation, Operation, And Maintenance	3
1-4 California Proposition 65 Warnings	4
1-5 Principal Safety Standards	4
1-6 EMF Information	4
<b>SECTION 2 – CONSIGNES DE SÉCURITÉ - LIRE AVANT UTILISATION</b>	<b>5</b>
2-1 Symboles utilisés	5
2-2 Dangers relatifs au soudage à l'arc	5
2-3 Symboles de dangers supplémentaires en relation avec l'installation, le fonctionnement et la maintenance	7
2-4 Proposition californienne 65 Avertissements	8
2-5 Principales normes de sécurité	8
2-6 Informations relatives aux CEM	9
<b>SECTION 3 – DEFINITIONS</b>	<b>10</b>
3-1 Additional Safety Symbol Definitions	10
3-2 Miscellaneous Symbols And Definitions	10
<b>SECTION 4 – SPECIFICATIONS</b>	<b>12</b>
4-1 Features And Benefits	12
4-2 Arc Controls	12
4-3 Serial Number And Rating Label Location	12
4-4 Software Licensing Agreement	12
4-5 Information About Default Weld Parameters And Settings	12
4-6 Unit Specifications	12
4-7 Dimensions And Weight	13
4-8 Environmental Specifications	13
4-9 Duty Cycle And Overheating	14
4-10 Static Output Characteristics	14
<b>SECTION 5 – INSTALLATION</b>	<b>15</b>
5-1 Selecting A Location	15
5-2 Selecting Cable Sizes*	16
5-3 Selecting Input Voltage	17
5-4 Weld Output Terminals	18
5-5 Connecting Weld Output Cables	18
5-6 Remote 14 Receptacle Information	19
5-7 Electrical Service Guide	20
5-8 Connecting 3-Phase Input Power	21
<b>SECTION 6 – GENERAL OPERATION</b>	<b>22</b>
6-1 Front Panel	22
6-2 Mode Switch Settings	23
6-3 Associating ArcReach Device To ArcReach Power Source	23
6-4 Optional — Voltage Reducing Device (VRD) Mode	24
6-5 Activating Optional Voltage Reducing Device (VRD) with DIP Switch	25
6-6 Alternate Configuration Functions	26
6-7 Updating Software	26
6-8 Obtaining Service.TXT file	26
<b>SECTION 7 – GMAW/FCAW OPERATION</b>	<b>27</b>
7-1 Typical Connection For Voltage-Sensing Feeder GMAW/FCAW Process	27
7-2 GMAW/FCAW - (Gas) Or FCAW-S (No Gas) Output-On Welding Modes	28
<b>SECTION 8 – SMAW/CAC-A OPERATION</b>	<b>29</b>
8-1 Typical Connection For SMAW And CAC-A Process	29
8-2 SMAW—Stick Output On Welding Mode	30
8-3 CAC-A—Gouge Output On Mode	31
<b>SECTION 9 – MAINTENANCE AND TROUBLESHOOTING</b>	<b>32</b>
9-1 Routine Maintenance	32
9-2 Blowing Out Inside Of Unit	32
9-3 Fault Code Diagnostics	33
9-4 Troubleshooting	34
<b>SECTION 10 – ELECTRICAL DIAGRAMS</b>	<b>35</b>

# SECTION 1 – SAFETY PRECAUTIONS – READ BEFORE USING

 Protect yourself and others from injury—read, follow, and save these important safety precautions and operating instructions.

## 1-1. Symbol Usage

 **DANGER!** – Indicates a hazardous situation which, if not avoided, will result in death or serious injury. The possible hazards are shown in the adjoining symbols or explained in the text.

 Indicates a hazardous situation which, if not avoided, could result in death or serious injury. The possible hazards are shown in the adjoining symbols or explained in the text.

**NOTICE** – Indicates statements not related to personal injury.

 Indicates special instructions.



This group of symbols means Warning! Watch Out! ELECTRIC SHOCK, MOVING PARTS, and HOT PARTS hazards. Consult symbols and related instructions below for necessary actions to avoid these hazards.

## 1-2. Arc Welding Hazards

 The symbols shown below are used throughout this manual to call attention to and identify possible hazards. When you see the symbol, watch out, and follow the related instructions to avoid the hazard. The safety information given below is only a summary of the more complete safety information found in the Principal Safety Standards. Read and follow all Safety Standards.

 Only qualified persons should install, operate, maintain, and repair this equipment. A qualified person is defined as one who, by possession of a recognized degree, certificate, or professional standing, or who by extensive knowledge, training and experience, has successfully demonstrated the ability to solve or resolve problems relating to the subject matter, the work, or the project and has received safety training to recognize and avoid the hazards involved.

 During operation, keep everybody, especially children, away.



### ELECTRIC SHOCK can kill.

Touching live electrical parts can cause fatal shocks or severe burns. The electrode and work circuit is electrically live whenever the output is on.

The input power circuit and machine internal circuits are also live when power is on. In semiautomatic or automatic wire welding, the wire, wire reel, drive roll housing, and all metal parts touching the welding wire are electrically live. Incorrectly installed or improperly grounded equipment is a hazard.

- Do not touch live electrical parts.
- Wear dry, hole-free insulating gloves and body protection.
- Insulate yourself from work and ground using dry insulating mats or covers big enough to prevent any physical contact with the work or ground.
- Do not use AC weld output in damp, wet, or confined spaces, or if there is a danger of falling.
- Do not store or use equipment in standing water.
- Use AC output ONLY if required for the welding process.
- If AC output is required, use remote output control if present on unit.
- Additional safety precautions are required when any of the following electrically hazardous conditions are present: in damp locations or while wearing wet clothing; on metal structures such as floors, gratings, or scaffolds; when in cramped positions such as sitting, kneeling, or lying; or when there is a high risk of unavoidable or accidental contact with the workpiece or ground. For these conditions, use the following equipment in order presented: 1) a semiautomatic DC constant voltage (wire) welder, 2) a DC manual

(stick) welder, or 3) an AC welder with reduced open-circuit voltage. In most situations, use of a DC, constant voltage wire welder is recommended. And, do not work alone!

- Disconnect input power or stop engine before installing or servicing this equipment. Lockout/tagout input power according to OSHA 29 CFR 1910.147 (see Safety Standards).
- Properly install, ground, and operate this equipment according to its Owner's Manual and national, state, and local codes.
- Always verify the supply ground—check and be sure that input power cord ground wire is properly connected to ground terminal in disconnect box or that cord plug is connected to a properly grounded receptacle outlet.
- When making input connections, attach proper grounding conductor first—double-check connections.
- Keep cords dry, free of oil and grease, and protected from hot metal and sparks.
- Frequently inspect input power cord and ground conductor for damage or bare wiring—replace immediately if damaged—bare wiring can kill.
- Turn off all equipment when not in use.
- Do not use worn, damaged, undersized, or repaired cables.
- Do not drape cables over your body.
- If earth grounding of the workpiece is required, ground it directly with a separate cable.
- Do not touch electrode if you are in contact with the work, ground, or another electrode from a different machine.
- Use only well-maintained equipment. Repair or replace damaged parts at once. Maintain unit according to manual.
- Do not touch electrode holders connected to two welding machines at the same time since double open-circuit voltage will be present.
- Wear a safety harness if working above floor level.
- Keep all panels and covers securely in place.
- Clamp work cable with good metal-to-metal contact to workpiece or worktable as near the weld as practical.
- Insulate work clamp when not connected to workpiece to prevent contact with any metal object.
- Do not connect more than one electrode or work cable to any single weld output terminal. Disconnect cable for process not in use.
- Use GFCI protection when operating auxiliary equipment in damp or wet locations.



### HOT PARTS can burn.

- Do not touch hot parts bare handed.
- Allow cooling period before working on equipment.
- To handle hot parts, use proper tools and/or wear heavy, insulated welding gloves and clothing to prevent burns.

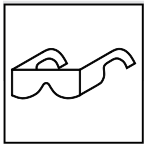

### FLYING METAL OR DIRT can injure eyes.

- Welding, chipping, wire brushing, and grinding cause sparks and flying metal. As welds cool, they can throw off slag.
- Wear approved safety glasses with side shields even under your welding helmet.



### FUMES AND GASES can be hazardous.

Welding produces fumes and gases. Breathing these fumes and gases can be hazardous to your health.

- Keep your head out of the fumes. Do not breathe the fumes.
- Ventilate the work area and/or use local forced ventilation at the arc to remove welding fumes and gases. The recommended way to determine adequate ventilation is to sample for the composition and quantity of fumes and gases to which personnel are exposed.
- If ventilation is poor, wear an approved air-supplied respirator.
- Read and understand the Safety Data Sheets (SDSs) and the manufacturer's instructions for adhesives, coatings, cleaners, consumables, coolants, degreasers, fluxes, and metals.
- Work in a confined space only if it is well ventilated, or while wearing an air-supplied respirator. Always have a trained watchperson nearby. Welding fumes and gases can displace air and lower the oxygen level causing injury or death. Be sure the breathing air is safe.
- Do not weld in locations near degreasing, cleaning, or spraying operations. The heat and rays of the arc can react with vapors to form highly toxic and irritating gases.
- Do not weld on coated metals, such as galvanized, lead, or cadmium plated steel, unless the coating is removed from the weld area, the area is well ventilated, and while wearing an air-supplied respirator. The coatings and any metals containing these elements can give off toxic fumes if welded.



### BUILDUP OF GAS can injure or kill.

- Shut off compressed gas supply when not in use.
- Always ventilate confined spaces or use approved air-supplied respirator.



### ARC RAYS can burn eyes and skin.

Arc rays from the welding process produce intense visible and invisible (ultraviolet and infrared) rays that can burn eyes and skin. Sparks fly off from the weld.

- Wear an approved welding helmet fitted with a proper shade of filter lenses to protect your face and eyes from arc rays and sparks when welding or watching (see ANSI Z49.1 and Z87.1 listed in Safety Standards).
- Wear approved safety glasses with side shields under your helmet.
- Use protective screens or barriers to protect others from flash, glare, and sparks; warn others not to watch the arc.
- Wear body protection made from leather or flame-resistant clothing (FRC). Body protection includes oil-free clothing such as leather gloves, heavy shirt, cuffless trousers, high shoes, and a cap.



### WELDING can cause fire or explosion.

Welding on closed containers, such as tanks, drums, or pipes, can cause them to blow up. Sparks can fly off from the welding arc. The flying sparks, hot workpiece, and hot equipment can cause fires and burns. Accidental contact of electrode to metal objects can cause sparks, explosion, overheating, or fire. Check and be sure the area is safe before doing any welding.

- Remove all flammables within 35 ft (10.7 m) of the welding arc. If this is not possible, tightly cover them with approved covers.
- Do not weld where flying sparks can strike flammable material.
- Protect yourself and others from flying sparks and hot metal.
- Be alert that welding sparks and hot materials from welding can easily go through small cracks and openings to adjacent areas.
- Watch for fire, and keep a fire extinguisher nearby.
- Be aware that welding on a ceiling, floor, bulkhead, or partition can cause fire on the hidden side.
- Do not cut or weld on tire rims or wheels. Tires can explode if heated. Repaired rims and wheels can fail. See OSHA 29 CFR 1910.177 listed in Safety Standards.
- Do not weld on containers that have held combustibles, or on closed containers such as tanks, drums, or pipes unless they are properly prepared according to AWS F4.1 (see Safety Standards).
- Do not weld where the atmosphere can contain flammable dust, gas, or liquid vapors (such as gasoline).
- Connect work cable to the work as close to the welding area as practical to prevent welding current from traveling long, possibly unknown paths and causing electric shock, sparks, and fire hazards.
- Do not use welder to thaw frozen pipes.
- Remove stick electrode from holder or cut off welding wire at contact tip when not in use.
- Wear body protection made from leather or flame-resistant clothing (FRC). Body protection includes oil-free clothing such as leather gloves, heavy shirt, cuffless trousers, high shoes, and a cap.
- Remove any combustibles, such as a butane lighter or matches, from your person before doing any welding.
- After completion of work, inspect area to ensure it is free of sparks, glowing embers, and flames.
- Use only correct fuses or circuit breakers. Do not oversize or bypass them.
- Follow requirements in OSHA 1910.252 (a) (2) (iv) and NFPA 51B for hot work and have a fire watcher and extinguisher nearby.
- Read and understand the Safety Data Sheets (SDSs) and the manufacturer's instructions for adhesives, coatings, cleaners, consumables, coolants, degreasers, fluxes, and metals.

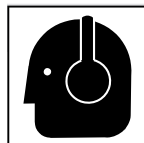

### NOISE can damage hearing.

Noise from some processes or equipment can damage hearing.

- Wear approved ear protection if noise level is high.



### ELECTRIC AND MAGNETIC FIELDS (EMF) can affect Implanted Medical Devices.

- Wearers of Pacemakers and other Implanted Medical Devices should keep away.
- Implanted Medical Device wearers should consult their doctor and the device manufacturer before going near arc welding, spot welding, gouging, plasma arc cutting, or induction heating operations.



### CYLINDERS can explode if damaged.

Compressed gas cylinders contain gas under high pressure. If damaged, a cylinder can explode. Since gas cylinders are normally part of the welding process, be sure to treat them carefully.

- Protect compressed gas cylinders from excessive heat, mechanical shocks, physical damage, slag, open flames, sparks, and arcs.
- Install cylinders in an upright position by securing to a stationary support or cylinder rack to prevent falling or tipping.
- Keep cylinders away from any welding or other electrical circuits.
- Never drape a welding torch over a gas cylinder.
- Never allow a welding electrode to touch any cylinder.

- Never weld on a pressurized cylinder—explosion will result.
- Use only correct compressed gas cylinders, regulators, hoses, and fittings designed for the specific application; maintain them and associated parts in good condition.
- Turn face away from valve outlet when opening cylinder valve. Do not stand in front of or behind the regulator when opening the valve.
- Keep protective cap in place over valve except when cylinder is in use or connected for use.
- Use the proper equipment, correct procedures, and sufficient number of persons to lift, move, and transport cylinders.
- Read and follow instructions on compressed gas cylinders, associated equipment, and Compressed Gas Association (CGA) publication P-1 listed in Safety Standards.

## 1-3. Additional Hazards For Installation, Operation, And Maintenance



### FIRE OR EXPLOSION hazard.

- Do not install or place unit on, over, or near combustible surfaces.
- Do not install unit near flammables.
- Do not overload building wiring—be sure power supply system is properly sized, rated, and protected to handle this unit.



### WELDING WIRE can injure.

- Do not press gun trigger until instructed to do so.
- Do not point gun toward any part of the body, other people, or any metal when threading welding wire.



### FALLING EQUIPMENT can injure.

- Use lifting eye to lift unit only, NOT running gear, gas cylinders, or any other accessories.
- Use correct procedures and equipment of adequate capacity to lift and support unit.
- If using lift forks to move unit, be sure forks are long enough to extend beyond opposite side of unit.
- Keep equipment (cables and cords) away from moving vehicles when working from an aerial location.
- Follow the guidelines in the Applications Manual for the Revised NIOSH Lifting Equation (Publication No. 94-110) when manually lifting heavy parts or equipment.

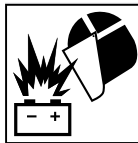

### BATTERY EXPLOSION can injure.

- Do not use welder to charge batteries or jump start vehicles unless it has a battery charging feature designed for this purpose.



### MOVING PARTS can injure.

- Keep away from moving parts such as fans.
- Keep all doors, panels, covers, and guards closed and securely in place.
- Have only qualified persons remove doors, panels, covers, or guards for maintenance and troubleshooting as necessary.
- Reinstall doors, panels, covers, or guards when maintenance is finished and before reconnecting input power.

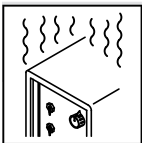

### OVERUSE can cause OVERHEATING.

- Allow cooling period; follow rated duty cycle.
- Reduce current or reduce duty cycle before starting to weld again.
- Do not block or filter airflow to unit.

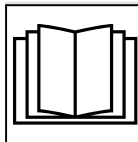

### READ INSTRUCTIONS.

- Read and follow all labels and the Owner's Manual carefully before installing, operating, or servicing unit. Read the safety information at the beginning of the manual and in each section.
- Use only genuine replacement parts from the manufacturer.
- Perform installation, maintenance, and service according to the Owner's Manuals, industry standards, and national, state, and local codes.

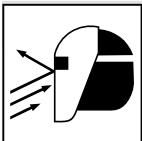

### FLYING SPARKS can injure.

- Wear a face shield to protect eyes and face.
- Shape tungsten electrode only on grinder with proper guards in a safe location wearing proper face, hand, and body protection.
- Sparks can cause fires—keep flammables away.



### H.F. RADIATION can cause interference.



### STATIC (ESD) can damage PC boards.

- Put on grounded wrist strap BEFORE handling boards or parts.
- Use proper static-proof bags and boxes to store, move, or ship PC boards.

- High-frequency (H.F.) can interfere with radio navigation, safety services, computers, and communications equipment.



### MOVING PARTS can injure.

- Keep away from moving parts.
- Keep away from pinch points such as drive rolls.

- Have only qualified persons familiar with electronic equipment perform this installation.
- The user is responsible for having a qualified electrician promptly correct any interference problem resulting from the installation.
- If notified by the FCC about interference, stop using the equipment at once.
- Have the installation regularly checked and maintained.
- Keep high-frequency source doors and panels tightly shut, keep spark gaps at correct setting, and use grounding and shielding to minimize the possibility of interference.



### ARC WELDING can cause interference.

- Electromagnetic energy can interfere with sensitive electronic equipment such as microprocessors, computers, and computer-driven equipment such

as robots.

- Be sure all equipment in the welding area is electromagnetically compatible.

- To reduce possible interference, keep weld cables as short as possible, close together, and down low, such as on the floor.
- Locate welding operation 100 meters from any sensitive electronic equipment.
- Be sure this welding machine is installed and grounded according to this manual.
- If interference still occurs, the user must take extra measures such as moving the welding machine, using shielded cables, using line filters, or shielding the work area.

## 1-4. California Proposition 65 Warnings

**⚠ WARNING – This product can expose you to chemicals including lead, which are known to the state of California to cause cancer and birth defects or other reproductive harm.**

For more information, go to [www.P65Warnings.ca.gov](http://www.P65Warnings.ca.gov).

## 1-5. Principal Safety Standards

*Safety in Welding, Cutting, and Allied Processes*, American Welding Society standard ANSI Standard Z49.1. Website: [www.aws.org](http://www.aws.org).

*Safe Practice For Occupational And Educational Eye And Face Protection*, ANSI Standard Z87.1, from American National Standards Institute. Website: [safetysupply.com](http://safetysupply.com).

*Safe Practices for the Preparation of Containers and Piping for Welding and Cutting*, American Welding Society Standard AWS F4.1. Website: [www.aws.org](http://www.aws.org).

*National Electrical Code*, NFPA Standard 70 from National Fire Protection Association. Website: [www.nfpa.org](http://www.nfpa.org).

*Safe Handling of Compressed Gases in Cylinders*, CGA Pamphlet P-1 from Compressed Gas Association. Website: [www.cganet.com](http://www.cganet.com).

*Safety in Welding, Cutting, and Allied Processes*, CSA Standard W117.2 from Canadian Standards Association. Website: [www.csagroup.org](http://www.csagroup.org).

*Standard for Fire Prevention During Welding, Cutting, and Other Hot Work*, NFPA Standard 51B from National Fire Protection Association. Website: [www.nfpa.org](http://www.nfpa.org).

OSHA, Occupational Safety and Health Standards for General Industry, Title 29, Code of Federal Regulations (CFR), Part 1910.177 Subpart N, Part 1910 Subpart Q, and Part 1926, Subpart J. Website: [www.osha.gov](http://www.osha.gov).

*OSHA Important Note Regarding the ACGIH TLV, Policy Statement on the Uses of TLVs and BEIs*. Website: [www.osha.gov](http://www.osha.gov).

*Applications Manual for the Revised NIOSH Lifting Equation* from the National Institute for Occupational Safety and Health (NIOSH). Website: [www.cdc.gov/NIOSH](http://www.cdc.gov/NIOSH).

SOM 2024–01

## 1-6. EMF Information

Electric current flowing through any conductor causes localized electric and magnetic fields (EMF). The current from arc welding (and allied processes including spot welding, gouging, plasma arc cutting, and induction heating operations) creates an EMF field around the welding circuit. EMF fields can interfere with some medical implants, e.g. pacemakers. Protective measures for persons wearing medical implants have to be taken. For example, restrict access for passers –by or conduct individual risk assessment for welders. All welders should use the following procedures in order to minimize exposure to EMF fields from the welding circuit:

1. Keep cables close together by twisting or taping them, or using a cable cover.
2. Do not place your body between welding cables. Arrange cables to one side and away from the operator.
3. Do not coil or drape cables around your body.

4. Keep head and trunk as far away from the equipment in the welding circuit as possible.
5. Connect work clamp to workpiece as close to the weld as possible.
6. Do not work next to, sit or lean on the welding power source.
7. Do not weld whilst carrying the welding power source or wire feeder.

### About Implanted Medical Devices:

Implanted Medical Device wearers should consult their doctor and the device manufacturer before performing or going near arc welding, spot welding, gouging, plasma arc cutting, or induction heating operations. If cleared by your doctor, then following the above procedures is recommended.

# SECTION 2 – CONSIGNES DE SÉCURITÉ - LIRE AVANT UTILISATION

 Pour écarter les risques de blessure pour vous-même et pour autrui — lire, appliquer et ranger en lieu sûr ces consignes relatives aux précautions de sécurité et au mode opératoire.

## 2-1. Symboles utilisés

 **DANGER!** – Indique une situation dangereuse qui si on l'évite pas peut donner la mort ou des blessures graves. Les dangers possibles sont montrés par les symboles joints ou sont expliqués dans le texte.

 Indique une situation dangereuse qui si on l'évite pas peut donner la mort ou des blessures graves. Les dangers possibles sont montrés par les symboles joints ou sont expliqués dans le texte.

**AVIS** – Indique des déclarations pas en relation avec des blessures personnelles.

 Indique des instructions spécifiques.



Ce groupe de symboles veut dire Avertissement! Attention! DANGER DE CHOC ELECTRIQUE, PIECES EN MOUVEMENT, et PIECES CHAUDES. Reportez-vous aux symboles et aux directives ci-dessous afin de connaître les mesures à prendre pour éviter tout danger.

## 2-2. Dangers relatifs au soudage à l'arc

 Les symboles représentés ci-dessous sont utilisés dans ce manuel pour attirer l'attention et identifier les dangers possibles. En présence de ce symbole, prendre garde et suivre les instructions afférentes pour éviter tout risque. Les consignes de sécurité présentées ci-après ne font que résumer l'information contenue dans les Normes de sécurité principales. Lire et suivre toutes les Normes de sécurité.

 L'installation, l'utilisation, l'entretien et les réparations ne doivent être confiés qu'à des personnes qualifiées. Une personne qualifiée est définie comme celle qui, par la possession d'un diplôme reconnu, d'un certificat ou d'un statut professionnel, ou qui, par une connaissance, une formation et une expérience approfondies, a démontré avec succès sa capacité à résoudre les problèmes liés à la tâche, le travail ou le projet et a reçu une formation en sécurité afin de reconnaître et d'éviter les risques inhérents.

 Au cours de l'utilisation, tenir toute personne à l'écart et plus particulièrement les enfants.



### UNE DÉCHARGE ÉLECTRIQUE peut entraîner la mort.

Le contact d'organes électriques sous tension peut provoquer des accidents mortels ou des brûlures graves. Le circuit de l'électrode et de la pièce est sous tension lorsque le courant est délivré à la sortie. Le circuit d'alimentation et les circuits internes de la machine sont également sous tension lorsque l'alimentation est sur Marche. Dans le mode de soudage avec du fil, le fil, le dérouleur, le bloc de commande du rouleau et toutes les parties métalliques en contact avec le fil sont sous tension électrique. Un équipement installé ou mis à la terre de manière incorrecte ou impropre constitue un danger.

- Ne pas toucher aux pièces électriques sous tension.
- Porter des gants isolants et des vêtements de protection secs et sans trous.
- S'isoler de la pièce à couper et du sol en utilisant des housses ou des tapis assez grands afin d'éviter tout contact physique avec la pièce à couper ou le sol.
- Ne pas utiliser de sortie de soudage CA dans des zones humides ou confinées ou s'il y a un risque de chute.
- Ne stockez pas et n'utilisez pas l'équipement dans de l'eau stagnante.
- Se servir d'une source électrique à courant électrique UNIQUEMENT si le procédé de soudage le demande.
- Si l'utilisation d'une source électrique à courant électrique s'avère nécessaire, se servir de la fonction de télécommande si l'appareil en est équipé.

- D'autres consignes de sécurité sont nécessaires dans les conditions suivantes : risques électriques dans un environnement humide ou si l'on porte des vêtements mouillés ; sur des structures métalliques telles que sols, grilles ou échafaudages ; en position coincée comme assise, à genoux ou couchée ; ou s'il y a un risque élevé de contact inévitable ou accidentel avec la pièce à souder ou le sol. Dans ces conditions, utiliser les équipements suivants, dans l'ordre indiqué : 1) un poste à souder DC à tension constante (à fil), 2) un poste à souder DC manuel (électrode) ou 3) un poste à souder AC à tension à vide réduite. Dans la plupart des situations, l'utilisation d'un poste à souder DC à fil à tension constante est recommandée. En outre, ne pas travailler seul !
- Couper l'alimentation ou arrêter le moteur avant de procéder à l'installation, à la réparation ou à l'entretien de l'appareil. Déverrouiller l'alimentation selon la norme OSHA 29 CFR 1910.147 (voir normes de sécurité).
- Brancher correctement la mise à la terre et utiliser cet appareil conformément à son manuel d'utilisateur et aux codes nationaux, provinciaux et municipaux.
- Toujours vérifier la mise à la terre — vérifier et assurez-vous que le conducteur de mise à la terre du cordon d'alimentation est bien raccordé à la borne de mise à la terre dans le boîtier de déconnexion ou que la fiche du cordon est raccordée à une prise correctement mise à la terre.
- En effectuant les raccordements d'entrée, fixer d'abord le conducteur de mise à la terre approprié et contre-vérifier les connexions.
- Les câbles doivent être exempts d'humidité, d'huile et de graisse; protégez-les contre les étincelles et les pièces métalliques chaudes.
- Vérifier fréquemment le cordon d'alimentation et le conducteur de mise à la terre afin de s'assurer qu'il n'est pas altéré ou dénudé -, le remplacer immédiatement s'il l'est -. Un fil dénudé peut entraîner la mort.
- L'équipement doit être hors tension lorsqu'il n'est pas utilisé.
- Ne pas utiliser des câbles usés, endommagés, de grosseur insuffisante ou mal épiés.
- Ne pas enrouler les câbles autour du corps.
- Si la pièce soudée doit être mise à la terre, le faire directement avec un câble distinct.
- Ne pas toucher l'électrode quand on est en contact avec la pièce, la terre ou une électrode provenant d'une autre machine.
- Ne pas toucher des porte électrodes connectés à deux machines en même temps à cause de la présence d'une tension à vide doublée.
- N'utiliser qu'un matériel en bon état. Réparer ou remplacer sur-le-champ les pièces endommagées. Entretien l'appareil conformément à ce manuel.

- Porter un harnais de sécurité si l'on doit travailler au-dessus du sol.
- S'assurer que tous les panneaux et couvercles sont correctement en place.
- Fixer le câble de retour de façon à obtenir un bon contact métal-métal avec la pièce à souder ou la table de travail, le plus près possible de la soudure.
- Isoler la pince de masse quand pas mis à la pièce pour éviter le contact avec tout objet métallique.
- Ne pas raccorder plus d'une électrode ou plus d'un câble de masse à une même borne de sortie de soudage. Débrancher le câble pour le procédé non utilisé.
- Utiliser une protection différentielle lors de l'utilisation d'un équipement auxiliaire dans des endroits humides ou mouillés.



### LES PIÈCES CHAUDES peuvent provoquer des brûlures.

- Ne pas toucher des parties chaudes à mains nues.
- Prévoir une période de refroidissement avant de travailler à l'équipement.
- Ne pas toucher aux pièces chaudes, utiliser les outils recommandés et porter des gants de soudage et des vêtements épais pour éviter les brûlures.

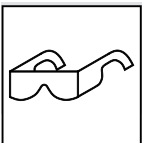

### DES PIÈCES DE METAL ou DES SALETES peuvent provoquer des blessures dans les yeux.

- Le soudage, l'écaillage, le passage de la pièce à la brosse en fil de fer, et le meulage génèrent des étincelles et des particules métalliques volantes. Pendant la période de refroidissement des soudures, elles risquent de projeter du laitier.
- Porter des lunettes de sécurité avec écrans latéraux ou un écran facial.



### LES FUMÉES ET LES GAZ peuvent être dangereux.

Le soudage génère des fumées et des gaz. Leur inhalation peut être dangereux pour votre santé.

- Eloigner votre tête des fumées. Ne pas respirer les fumées.
- À l'intérieur, ventiler la zone et/ou utiliser une ventilation forcée au niveau de l'arc pour l'évacuation des fumées et des gaz de soudage. Pour déterminer la bonne ventilation, il est recommandé de procéder à un prélèvement pour la composition et la quantité de fumées et de gaz auxquelles est exposé le personnel.
- Si la ventilation est médiocre, porter un respirateur anti-vapeurs approuvé.
- Lire et comprendre les fiches de données de sécurité et les instructions du fabricant concernant les adhésifs, les revêtements, les nettoyants, les consommables, les produits de refroidissement, les dégraissateurs, les flux et les métaux.
- Travailler dans un espace fermé seulement s'il est bien ventilé ou en portant un respirateur à alimentation d'air. Demander toujours à un surveillant dûment formé de se tenir à proximité. Des fumées et des gaz de soudage peuvent déplacer l'air et abaisser le niveau d'oxygène provoquant des blessures ou des accidents mortels. S'assurer que l'air de respiration ne présente aucun danger.
- Ne pas souder dans des endroits situés à proximité d'opérations de dégraissage, de nettoyage ou de pulvérisation. La chaleur et les rayons de l'arc peuvent réagir en présence de vapeurs et former des gaz hautement toxiques et irritants.
- Ne pas souder des métaux munis d'un revêtement, tels que l'acier galvanisé, plaqué en plomb ou au cadmium à moins que le revêtement n'ait été enlevé dans la zone de soudure, que l'endroit soit bien ventilé, et en portant un respirateur à alimentation d'air. Les revêtements et tous les métaux renfermant ces éléments peuvent dégager des fumées toxiques en cas de soudage.



### LES ACCUMULATIONS DE GAZ risquent de provoquer des blessures ou même la mort.

- Fermer l'alimentation du gaz comprimé en cas de non utilisation.
- Veiller toujours à bien aérer les espaces confinés ou se servir d'un respirateur d'adduction d'air homologué.



### LES RAYONS DE L'ARC peuvent provoquer des brûlures dans les yeux et sur la peau.

Le rayonnement de l'arc du procédé de soudage génère des rayons visibles et invisibles intenses (ultraviolets et infrarouges) susceptibles de provoquer des brûlures dans les yeux et sur la peau. Des étincelles sont projetées pendant le soudage.

- Porter un casque de soudage approuvé muni de verres filtrants approprié pour protéger visage et yeux pendant le soudage (voir ANSI Z49.1 et Z87.1 énuméré dans les normes de sécurité).
- Porter des lunettes de sécurité avec écrans latéraux même sous votre casque.
- Avoir recours à des écrans protecteurs ou à des rideaux pour protéger les autres contre les rayonnements les éblouissements et les étincelles ; prévenir toute personne sur les lieux de ne pas regarder l'arc.
- Porter une protection corporelle en cuir ou des vêtements ignifuges (FRC). La protection du corps comporte des vêtements sans huile, comme des gants de cuir, une chemise solide, des pantalons sans revers, des chaussures hautes et une casquette.



### LE SOUDAGE peut provoquer un incendie ou une explosion.

Le soudage effectué sur des conteneurs fermés tels que des réservoirs, tambours ou des conduites peut provoquer leur éclatement. Des étincelles peuvent être projetées de l'arc de soudure. La projection d'étincelles, des pièces chaudes et des équipements chauds peut provoquer des incendies et des brûlures. Le contact accidentel de l'électrode avec des objets métalliques peut provoquer des étincelles, une explosion, un surchauffement ou un incendie. Avant de commencer le soudage, vérifier et s'assurer que l'endroit ne présente pas de danger.

- Déplacer toutes les substances inflammables à une distance de 10,7 m de l'arc de soudage. En cas d'impossibilité les recouvrir soigneusement avec des protections homologuées.
- Ne pas souder dans un endroit où des étincelles peuvent tomber sur des substances inflammables.
- Se protéger et d'autres personnes de la projection d'étincelles et de métal chaud.
- Des étincelles et des matériaux chauds du soudage peuvent facilement passer dans d'autres zones en traversant de petites fissures et des ouvertures.
- Surveiller tout déclenchement d'incendie et tenir un extincteur à proximité.
- Le soudage effectué sur un plafond, plancher, paroi ou séparation peut déclencher un incendie de l'autre côté.
- Ne pas couper ou souder des jantes ou des roues. Les pneus peuvent exploser s'ils sont chauffés. Les jantes et les roues réparées peuvent défaillir. Voir OSHA 29 CFR 1910.177 énuméré dans les normes de sécurité.
- Ne pas effectuer le soudage sur des conteneurs fermés tels que des réservoirs, tambours, ou conduites, à moins qu'ils n'aient été préparés correctement conformément à AWS F4.1 (voir les Normes de Sécurité).
- Ne pas souder là où l'air ambiant pourrait contenir des poussières, gaz ou émanations inflammables (vapeur d'essence, par exemple).

- Brancher le câble de masse sur la pièce le plus près possible de la zone de soudage pour éviter le transport du courant sur une longue distance par des chemins inconnus éventuels en provoquant des risques d'électrocution, d'étincelles et d'incendie.
- Ne pas utiliser le poste de soudage pour dégeler des conduites gelées.
- En cas de non utilisation, enlever la bague d'électrode du porte-électrode ou couper le fil à la pointe de contact.
- Porter une protection corporelle en cuir ou des vêtements ignifuges (FRC). La protection du corps comporte des vêtements sans huile, comme des gants de cuir, une chemise solide, des pantalons sans revers, des chaussures hautes et une casquette.
- Avant de souder, retirer toute substance combustible de vos poches telles qu'un allumeur au butane ou des allumettes.
- Une fois le travail achevé, assurez-vous qu'il ne reste aucune trace d'étincelles incandescentes ni de flammes.
- Utiliser exclusivement des fusibles ou coupe-circuits appropriés. Ne pas augmenter leur puissance; ne pas les ponter.
- Suivre les recommandations dans OSHA 1910.252 (a) (2) (iv) et NFPA 51B pour les travaux à chaud et avoir de la surveillance et un extincteur à proximité.
- Lire et comprendre les fiches de données de sécurité et les instructions du fabricant concernant les adhésifs, les revêtements, les nettoyants, les consommables, les produits de refroidissement, les dégraissants, les flux et les métaux.

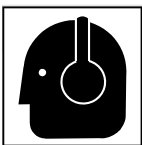

### Le BRUIT peut endommager l'ouïe.

Le bruit des processus et des équipements peut affecter l'ouïe.

- Porter des protections approuvées pour les oreilles si le niveau sonore est trop élevé.



### Les CHAMPS ÉLECTROMAGNÉTIQUES (CEM) peuvent affecter les implants médicaux.

- Les porteurs de stimulateurs cardiaques et autres implants médicaux doivent rester à distance.

- Les porteurs d'implants médicaux doivent consulter leur médecin et le fabricant du dispositif avant de s'approcher de la zone où se déroule du soudage à l'arc, du soudage par points, du gougeage, de la découpe plasma ou une opération de chauffage par induction.

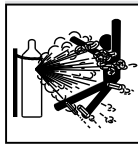

### Si des BOUTEILLES sont endommagées, elles pourront exploser.

Des bouteilles de gaz comprimé protecteur contiennent du gaz sous haute pression. Si une bouteille est endommagée, elle peut exploser. Du fait que les bouteilles de gaz font normalement partie du procédé de soudage, les manipuler avec précaution.

- Protéger les bouteilles de gaz comprimé d'une chaleur excessive, des chocs mécaniques, des dommages physiques, du laitier, des flammes ouvertes, des étincelles et des arcs.
- Placer les bouteilles debout en les fixant dans un support stationnaire ou dans un porte-bouteilles pour les empêcher de tomber ou de se renverser.
- Tenir les bouteilles éloignées des circuits de soudage ou autres circuits électriques.
- Ne jamais placer une torche de soudage sur une bouteille à gaz.
- Une électrode de soudage ne doit jamais entrer en contact avec une bouteille.
- Ne jamais souder une bouteille pressurisée - risque d'explosion.
- Utiliser seulement des bouteilles de gaz comprimé, régulateurs, tuyaux et raccords convenables pour cette application spécifique; les maintenir ainsi que les éléments associés en bon état.
- Tourner le dos à la sortie de vanne lors de l'ouverture de la vanne de la bouteille. Ne pas se tenir devant ou derrière le régulateur lors de l'ouverture de la vanne.
- Maintenir le chapeau de protection sur la soupape, sauf en cas d'utilisation ou de branchement de la bouteille.
- Utilisez les équipements corrects, les bonnes procédures et suffisamment de personnes pour soulever, déplacer et transporter les bouteilles.
- Lire et suivre les instructions sur les bouteilles de gaz comprimé, l'équipement connexe et le dépliant P-1 de la CGA (Compressed Gas Association) mentionné dans les principales normes de sécurité.

## 2-3. Symboles de dangers supplémentaires en relation avec l'installation, le fonctionnement et la maintenance



### Risque D'INCENDIE OU D'EXPLOSION.

- Ne pas placer l'appareil sur, au-dessus ou à proximité de surfaces inflammables.
- Ne pas installer l'appareil à proximité de produits inflammables
- Ne pas surcharger l'installation électrique – s'assurer que l'alimentation est correctement dimensionnée et protégée avant de mettre l'appareil en service.



### LA CHUTE DE L'ÉQUIPEMENT peut provoquer des blessures.

- Utiliser l'anneau de levage uniquement pour soulever l'appareil, NON PAS les organes de roulement, les bouteilles de gaz ou tout autre accessoire.
- Utilisez les procédures correctes et des équipements d'une capacité appropriée pour soulever et supporter l'appareil.
- En utilisant des fourches de levage pour déplacer l'unité, s'assurer que les fourches sont suffisamment longues pour dépasser du côté opposé de l'appareil.

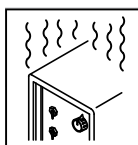

### L'EMPLOI EXCESSIF peut SURCHAUFFER L'ÉQUIPEMENT.

- Laisser l'équipement refroidir ; respecter le facteur de marche nominal.
- Réduire le courant ou le cycle opératoire avant de recommencer le soudage.
- Ne pas obstruer les passages d'air du poste.

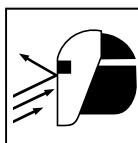

### LES ÉTINCELLES PROJÉTÉES peuvent provoquer des blessures.

- Porter un écran facial pour protéger le visage et les yeux.

- Affûter l'électrode au tungstène uniquement à la meuleuse dotée de protecteurs. Cette manœuvre est à exécuter dans un endroit sûr lorsque l'on porte l'équipement homologué de protection du visage, des mains et du corps.
- Les étincelles risquent de causer un incendie - éloigner toute substance inflammable.



### LES CHARGES ÉLECTROSTATIQUES peuvent endommager les circuits imprimés.

- Établir la connexion avec la barrette de terre AVANT de manipuler des cartes ou des pièces.
- Utiliser des pochettes et des boîtes antistatiques pour stocker, déplacer ou expédier des cartes de circuits imprimés.



### Les PIÈCES MOBILES peuvent causer des blessures.

- Ne pas s'approcher des organes mobiles.
- Ne pas s'approcher des points de coincement tels que des rouleaux de commande.



### LES FILS DE SOUDAGE peuvent provoquer des blessures.

- Ne pas appuyer sur la gachette avant d'en avoir reçu l'instruction.
- Ne pas diriger le pistolet vers soi, d'autres personnes ou toute pièce mécanique en engageant le fil de soudage.



### L'EXPLOSION DE LA BATTERIE peut provoquer des blessures.

- Ne pas utiliser l'appareil de soudage pour charger des batteries ou faire démarrer des véhicules à l'aide de câbles de démarrage, sauf si l'appareil

dispose d'une fonctionnalité de charge de batterie destinée à cet usage.



### Les PIÈCES MOBILES peuvent causer des blessures.

- S'abstenir de toucher des organes mobiles tels que des ventilateurs.
- Maintenir fermés et verrouillés les portes, panneaux, recouvrements et dispositifs de protection.
- Lorsque cela est nécessaire pour des travaux d'entretien et de dépannage, faire retirer les portes, panneaux, recouvrements ou dispositifs de protection uniquement par du personnel qualifié.
- Remettre les portes, panneaux, recouvrements ou dispositifs de protection quand l'entretien est terminé et avant de rebrancher l'alimentation électrique.

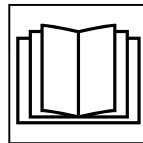

### LIRE LES INSTRUCTIONS.

- Lire et appliquer les instructions sur les étiquettes et le Mode d'emploi avant l'installation, l'utilisation ou l'entretien de l'appareil. Lire les informations de sécurité au début du manuel et dans chaque section.
- N'utiliser que des pièces de remplacement provenant du fabricant.
- Effectuer l'installation, l'entretien et toute intervention selon les manuels d'utilisateurs, les normes nationales, provinciales et de l'industrie, ainsi que les codes municipaux.

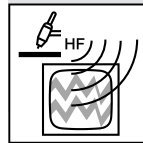

### LE RAYONNEMENT HAUTE FRÉQUENCE (H.F.) risque de provoquer des interférences.

- Le rayonnement haute fréquence (H.F.) peut provoquer des interférences avec les équipements de radio-navigation et de communication, les services de sécurité et les ordinateurs.
- Demander seulement à des personnes qualifiées familiarisées avec des équipements électroniques de faire fonctionner l'installation.
- L'utilisateur est tenu de faire corriger rapidement par un électricien qualifié les interférences résultant de l'installation.
- Si le FCC signale des interférences, arrêter immédiatement l'appareil.
- Effectuer régulièrement le contrôle et l'entretien de l'installation.
- Maintenir soigneusement fermés les portes et les panneaux des sources de haute fréquence, maintenir les éclateurs à une distance correcte et utiliser une terre et un blindage pour réduire les interférences éventuelles.

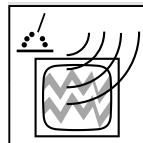

### LE SOUDAGE À L'ARC risque de provoquer des interférences.

- L'énergie électromagnétique risque de provoquer des interférences pour l'équipement électronique sensible tel que les ordinateurs et l'équipement commandé par ordinateur tel que les robots.
- Veiller à ce que tout l'équipement de la zone de soudage soit compatible électromagnétiquement.
- Pour réduire la possibilité d'interférence, maintenir les câbles de soudage aussi courts que possible, les grouper, et les poser aussi bas que possible (ex. par terre).
- Veiller à souder à une distance de 100 mètres de tout équipement électronique sensible.
- Veiller à ce que ce poste de soudage soit posé et mis à la terre conformément à ce mode d'emploi.
- En cas d'interférences après avoir pris les mesures précédentes, il incombe à l'utilisateur de prendre des mesures supplémentaires telles que le déplacement du poste, l'utilisation de câbles blindés, l'utilisation de filtres de ligne ou la pose de protecteurs dans la zone de travail.

## 2-4. Proposition californienne 65 Avertissements

**AVERTISSEMENT – Ce produit peut vous exposer à des produits chimiques tels que le plomb, reconnus par l'État de Californie comme cancérigènes et sources de malformations ou d'autres troubles de la reproduction.**

Pour plus d'informations, consulter [www.P65Warnings.ca.gov](http://www.P65Warnings.ca.gov).

## 2-5. Principales normes de sécurité

*Safety in Welding, Cutting, and Allied Processes*, American Welding Society standard ANSI Standard Z49.1. Website: [www.aws.org](http://www.aws.org).

*Safe Practice For Occupational And Educational Eye And Face Protection*, ANSI Standard Z87.1, from American National Standards Institute. Website: [safetyequipment.org](http://safetyequipment.org).

*Safe Practices for the Preparation of Containers and Piping for Welding and Cutting*, American Welding Society Standard AWS F4.1. Website: [www.aws.org](http://www.aws.org).

*National Electrical Code*, NFPA Standard 70 from National Fire Protection Association. Website: [www.nfpa.org](http://www.nfpa.org).

*Safe Handling of Compressed Gases in Cylinders*, CGA Pamphlet P-1 from Compressed Gas Association. Website: [www.cganet.com](http://www.cganet.com).

*Safety in Welding, Cutting, and Allied Processes*, CSA Standard W117.2 from Canadian Standards Association. Website: [www.csa-group.org](http://www.csa-group.org).

*Standard for Fire Prevention During Welding, Cutting, and Other Hot Work*, NFPA Standard 51B from National Fire Protection Association. Website: [www.nfpa.org](http://www.nfpa.org).

OSHA, Occupational Safety and Health Standards for General Industry, Title 29, Code of Federal Regulations (CFR), Part 1910.177

Subpart N, Part 1910 Subpart Q, and Part 1926, Subpart J. Website: [www.osha.gov](http://www.osha.gov).

*OSHA Important Note Regarding the ACGIH TLV, Policy Statement on the Uses of TLVs and BEIs*. Website: [www.osha.gov](http://www.osha.gov).

*Applications Manual for the Revised NIOSH Lifting Equation* from the National Institute for Occupational Safety and Health (NIOSH). Website: [www.cdc.gov/NIOSH](http://www.cdc.gov/NIOSH).

SOM\_fre 2024-01

## 2-6. Informations relatives aux CEM

Le courant électrique qui traverse tout conducteur génère des champs électromagnétiques (CEM) à certains endroits. Le courant issu d'un soudage à l'arc (et de procédés connexes, y compris le soudage par points, le gougeage, le découpage plasma et les opérations de chauffage par induction) crée un champ électromagnétique (CEM) autour du circuit de soudage. Les champs électromagnétiques produits peuvent causer interférence à certains implants médicaux, p. ex. les stimulateurs cardiaques. Des mesures de protection pour les porteurs d'implants médicaux doivent être prises: par exemple, des restrictions d'accès pour les passants ou une évaluation individuelle des risques pour les soudeurs. Tous les soudeurs doivent appliquer les procédures suivantes pour minimiser l'exposition aux CEM provenant du circuit de soudage:

1. Rassembler les câbles en les torsadant ou en les attachant avec du ruban adhésif ou avec une housse.
2. Ne pas se tenir au milieu des câbles de soudage. Disposer les câbles d'un côté et à distance de l'opérateur.

3. Ne pas courber et ne pas entourer les câbles autour de votre corps.
4. Maintenir la tête et le torse aussi loin que possible du matériel du circuit de soudage.
5. Connecter la pince sur la pièce aussi près que possible de la soudure.
6. Ne pas travailler à proximité d'une source de soudage, ni s'asseoir ou se pencher dessus.
7. Ne pas souder tout en portant la source de soudage ou le dévidoir.



### En ce qui concerne les implants médicaux :

Les porteurs d'implants doivent d'abord consulter leur médecin avant de s'approcher des opérations de soudage à l'arc, de soudage par points, de gougeage, du coupage plasma ou de chauffage par induction. Si le médecin approuve, il est recommandé de suivre les procédures précédentes.























# SECTION 3 – DEFINITIONS



## 3-1. Additional Safety Symbol Definitions

Some symbols are found only on CE products.

	Warning! Watch Out! There are possible hazards as shown by the symbols.
	When power is applied failed parts can explode or cause other parts to explode.

## 3-2. Miscellaneous Symbols And Definitions

<b>A</b>	Amperage		Air Carbon Arc Cutting (CAC-A)	<b>+</b>	Positive
~	Alternating Current (AC)		Frame or Chassis		Constant Voltage
<b>V</b>	Voltage		Remote		Shielded Metal Arc Welding (SMAW)
	On		Negative	<b>U<sub>1</sub></b>	Primary Voltage
	Input Voltage		Gas Output	<b>IP</b>	Degree of Protection
	Protective Earth (Ground)		Foot Control	<b>I<sub>1eff</sub></b>	Maximum Effective Supply Current
	Line Connection		Gas Metal Arc Welding (GMAW)		Variable Inductance
	Three Phase Static Frequency Converter-Transformer-Rectifier	<b>U<sub>2</sub></b>	Conventional Load Voltage		Output
<b>X</b>	Duty Cycle		Panel		Off
%	Percent	<b>I<sub>2</sub></b>	Rated Welding Current		Direct Current (DC)
3~	Three Phase		Increase		Constant Current
	Lift-Arc Operation (GTAW)		Circuit Breaker		Arc Force

	Flux Cored Arc Welding (FCAW)
	Suitable For Welding In An Environment With Increased Risk Of Electric Shock
$U_0$	Rated No Load Voltage (OCV)

$Hz$	Hertz
$I_{1max}$	Rated Maximum Supply Current

	Gas Tungsten Arc Welding (GTAW)
$U_r$	Reduced Rated No-Load Voltage

# SECTION 4 – SPECIFICATIONS

## 4-1. Features And Benefits

**LVC<sup>™</sup> Line Voltage Compensation** is circuitry that keeps the power source output constant regardless of input power fluctuation.

**Wind Tunnel Technology<sup>™</sup>** circulates air over components that require cooling, not over electronic circuitry, which reduces contaminants and improves reliability in harsh welding environments.

**Fan-On-Demand<sup>™</sup>** cooling system operates only when needed, reducing noise, energy use and the amount of contaminants pulled through the machine.

**Thermal Overload Protection** automatically shuts down the unit, only when necessary to prevent damage to internal components if the duty cycle is exceeded or air flow and cooling are restricted (see Section 4-9).

**Auto Remote Sense** enables the unit to automatically sense the connection of a remote control. Operation of the remote control is dependent on the Mode Switch Setting (see Section 6-2).

**Adaptive Hot Start<sup>™</sup>** for Stick increases the output amperage at the start of a weld to eliminate electrode sticking (see Section 8-2).

**ArcReach<sup>™</sup> Remote Control** allows remote control of various functions of the power source by an ArcReach compatible wire feeder or remote control device, without the use of a control cable (see Section 6-3). Operation of the ArcReach feature is dependent on the Mode Switch Setting (see section pertaining to process being used).

## 4-2. Arc Controls

**Arc Control in Stick Modes** allows arc characteristics, soft versus stiff, to be changed for specific applications and electrodes (see Section 8-2).

**Arc Control in Wire Modes** influences the arc stiffness, bead width and appearance, and puddle fluidity (see Section 7-2).

## 4-3. Serial Number And Rating Label Location

The serial number and rating information for this product is located on the rear panel. Use rating label to determine input power requirements and/or rated output. For future reference, write serial number in space provided on back cover of this manual.

## 4-4. Software Licensing Agreement

The End User License Agreement and any third-party notices and terms and conditions pertaining to third-party software can be found at <https://www.millerwelds.com/eula> and are incorporated by reference herein.

## 4-5. Information About Default Weld Parameters And Settings

**NOTICE** – Each welding application is unique. Although certain Miller Electric products are designed to determine and default to certain typical welding parameters and settings based upon specific and relatively limited application variables input by the end user, such default settings are for reference purposes only; and final weld results can be affected by other variables and application-specific circumstances. The appropriateness of all parameters and settings should be evaluated and modified by the end user as necessary based upon application-specific requirements. The end user is solely responsible for selection and coordination of appropriate equipment, adoption or adjustment of default weld parameters and settings, and ultimate quality and durability of all resultant welds. Miller Electric expressly disclaims any and all implied warranties including any implied warranty of fitness for a particular purpose.

## 4-6. Unit Specifications

 Do not use information in unit specifications table to determine electrical service requirements. See Sections 5-7 and 5-8 for information on connecting input power.

 This equipment will deliver rated output at an ambient air temperature up to 104°F (40°C).

### A. Input Voltage And Current At Rated Output (380V 50Hz)

Process	Output Ratings			Amperes Input At Rated Output	Input Power (380V 50 Hz Three Phase)	
	Current (Amperes)	Voltage (DC)	Duty Cycle (%)	380 VAC (50 Hz)	KW	KVA
SMAW EXX10 (Stick)	650	44	100	50.9	31.5	33.5
	750	44	60	59.2	36.6	38.9
SMAW EXX18 (Stick) GMAW/FCAW (Gas) FCAW-S (+) / (-) (No Gas) CAC-A (Gouge)	650	44	100	50.9	31.5	33.5
	750	44	60	59.2	36.6	38.6
	815	44	25	64.5	39.8	42.4
Idle (Fan Off)	N/A			0.28	0.057	0.22

Process	Output Ratings			Amperes Input At Rated Output	Input Power (380V 50 Hz Three Phase)	
	Current (Amperes)	Voltage (DC)	Duty Cycle (%)	380 VAC (50 Hz)	KW	KVA
Idle (Fan On)				0.37	0.142	0.3

### B. Input Voltage And Current At Rated Output (460V 60Hz)

Process	Output Ratings			Amperes Input At Rated Output	Input Power (460V 60 Hz Three Phase)	
	Current (Amperes)	Voltage (DC)	Duty Cycle (%)	460 VAC (60 Hz)	KW	KVA
SMAW EXX10 (Stick)	650	44	100	43.1	31	34.4
	750	44	60	49.4	35.9	39.4
SMAW EXX18 (Stick) GMAW/FCAW (Gas) FCAW-S (+) / (-) (No Gas) CAC-A (Gouge)	650	44	100	43.1	31	34.4
	750	44	60	49.4	35.9	39.4
	815	44	25	53.8	39.1	42.8
Idle (Fan Off)	N/A			0.28	0.057	0.22
Idle (Fan On)	N/A			0.37	0.142	0.3

### C. Output Range

Process		Output Range	Rated No-Load Voltage			
			380 VAC (U <sub>0</sub> )	460 VAC (U <sub>0</sub> )	380 VAC (U <sub>r</sub> )	460 VAC (U <sub>r</sub> )
SMAW EXX10/ EXX18 (Stick)	Output On	35A-815A	67 V	82 V	12 V	12 V
CAC-A (Gouge)	Output On	125A-815A	67 V	82 V	12 V	12 V
GMAW/FCAW (Gas) FCAW-S (+) / (-) (No Gas)	Output On	15V-44V	67 V	82 V	24 V	24 V

\*Rated No-Load Voltage can be reduced (U<sub>r</sub>) by enabling VRD mode. See Section 6-4 for more information.

## 4-7. Dimensions And Weight

Hole Layout Dimensions	
A	14-1/4 in. (362 mm)
B	30-1/4 in. (768 mm)
C	11/16 in. (17 mm)
Weight	
182 lb (82.5 kg)	

269320-A

291148-A

## 4-8. Environmental Specifications

### A. IP Rating

IP Rating
IP23
This equipment is designed for outdoor use.

## B. Temperature Specifications

Operating Temperature Range*	Storage/Transportation Temperature Range
14 to 104°F (-10 to 40°C)	-4 to 131°F (-20 to 55°C)

\*Output is derated at temperatures above 104°F (40°C).

### 4-9. Duty Cycle And Overheating



Duty Cycle is percentage of 10 minutes that unit can weld at rated load without overheating.

If unit overheats, output stops, error message is displayed (see Section 12-3), and cooling fan runs. Wait for unit to cool and error message to clear. Reduce amperage or duty cycle before welding.

**NOTICE** – Exceeding duty cycle can damage unit and void warranty.

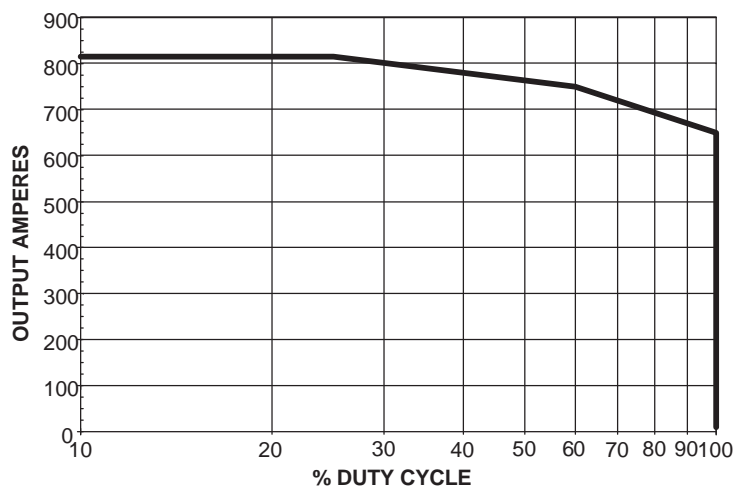

% Duty Cycle	Output Amperes
10	820
20	820
30	820
40	800
50	780
60	750
70	700
80	650
90	600
100	600

**100% Duty Cycle At 650 Amperes**

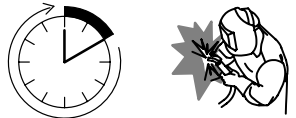

Continuous Welding

**60% Duty Cycle At 750 Amperes**

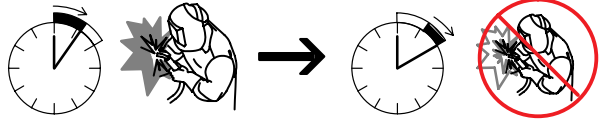

6 Minutes Welding      4 Minutes Resting

**25% Duty Cycle At 815 Amperes**



2 1/2 Minutes Welding      7 1/2 Minutes Resting

**Overheating**

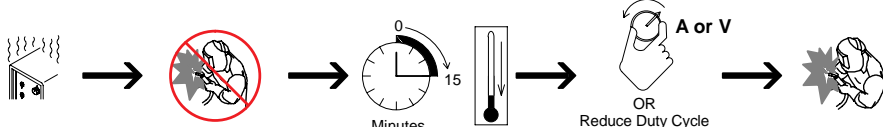

Minutes      OR      Reduce Duty Cycle

### 4-10. Static Output Characteristics

The static (output) characteristics of the welding power source can be described as *flat* during the GMAW and FCAW processes and *drooping* during the SMAW and CAC-A processes. Static characteristics are also affected by control settings (including software), electrode, shielding gas, weldment material, and other factors. Contact the factory for specific information on the static characteristics of the welding power source.

# SECTION 5 – INSTALLATION

## 5-1. Selecting A Location



### Movement

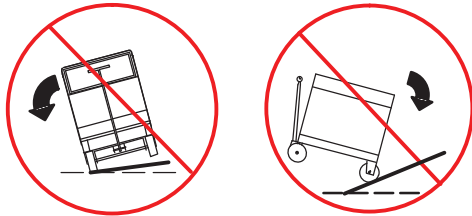
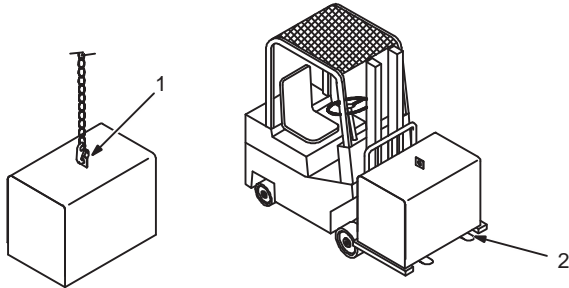

### Location And Airflow

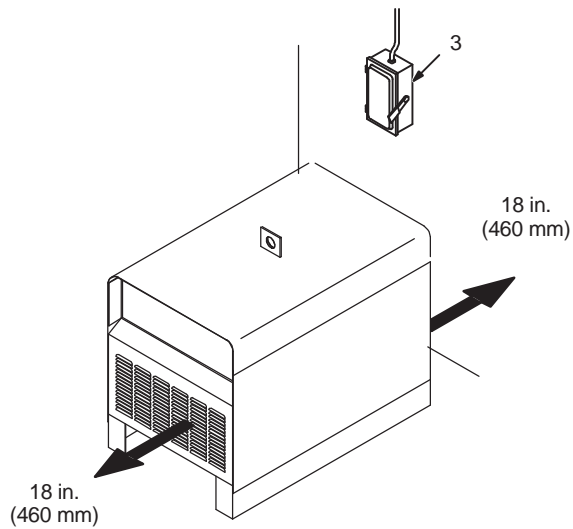

 Do not move or operate unit where it could tip.

 Special installation may be required where gasoline or volatile liquids are present - see NEC Article 511 or CEC Section 20.

1 Lifting Eye

2 Lifting Forks

Use lifting eye or lifting forks to move unit.

If using lifting forks, extend forks beyond opposite side of unit.

3 Line Disconnect Device

Locate unit near correct input power supply.

## 5-2. Selecting Cable Sizes\*

**NOTICE** – The Total Cable Length in Weld Circuit (see table below) is the combined length of both weld cables. For example, if the power source is 100 ft (30 m) from the workpiece, the total cable length in the weld circuit is 200 ft (2 cables x 100 ft). Use the 200 ft (60 m) column to determine cable size.

	Weld Cable Size** and Total Cable (Copper) Length in Weld Circuit Not Exceeding***							
	100 ft (30 m) or Less		150 ft (45 m)	200 ft (60 m)	250 ft (70 m)	300 ft (90 m)	350 ft (105 m)	400 ft (120 m)
Welding Amperes	10 - 60% Duty Cycle AWG (mm <sup>2</sup> )	60 - 100% Duty Cycle AWG (mm <sup>2</sup> )	10 - 100% Duty Cycle AWG (mm <sup>2</sup> )					
100	4 (20)	4 (20)	4 (20)	3 (30)	2 (35)	1 (50)	1/0 (60)	1/0 (60)
150	3 (30)	3 (30)	2 (35)	1 (50)	1/0 (60)	2/0 (70)	3/0 (95)	3/0 (95)
200	3 (30)	2 (35)	1 (50)	1/0 (60)	2/0 (70)	3/0 (95)	4/0 (120)	4/0 (120)
250	2 (35)	1 (50)	1/0 (60)	2/0 (70)	3/0 (95)	4/0 (120)	2x2/0 (2x70)	2x2/0 (2x70)
300	1 (50)	1/0 (60)	2/0 (70)	3/0 (95)	4/0 (120)	2x2/0 (2x70)	2x3/0 (2x95)	2x3/0 (2x95)
350	1/0 (60)	2/0 (70)	3/0 (95)	4/0 (120)	2x2/0 (2x70)	2x3/0 (2x95)	2x3/0 (2x95)	2x4/0 (2x120)
400	1/0 (60)	2/0 (70)	3/0 (95)	4/0 (120)	2x2/0 (2x70)	2x3/0 (2x95)	2x4/0 (2x120)	2x4/0 (2x120)
500	2/0 (70)	3/0 (95)	4/0 (120)	2x2/0 (2x70)	2x3/0 (2x95)	2x4/0 (2x120)	3x3/0 (3x95)	3x3/0 (3x95)
600	3/0 (95)	4/0 (120)	2x2/0 (2x70)	2x3/0 (2x95)	2x4/0 (2x120)	3x3/0 (3x95)	3x4/0 (3x120)	3x4/0 (3x120)
700	4/0 (120)	2x2/0 (2x70)	2x3/0 (2x95)	2x4/0 (2x120)	3x3/0 (3x95)	3x4/0 (3x120)	3x4/0 (3x120)	4x4/0 (4x120)
800	4/0 (120)	2x2/0 (2x70)	2x3/0 (2x95)	2x4/0 (2x120)	3x4/0 (3x120)	3x4/0 (3x120)	4x4/0 (4x120)	4x4/0 (4x120)



\* This chart is a general guideline and may not suit all applications. If cable overheats, use next size larger cable.

\*\*Weld cable size (AWG) is based on either a 4 volts or less drop or a current density of at least 300 circular mils per ampere. ( ) = mm<sup>2</sup> for metric use.

\*\*\*For distances longer than those shown in this guide, see AWS Fact Sheet No. 39, Welding Cables, available from the American Welding Society at <http://www.aws.org>.

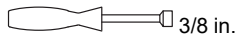
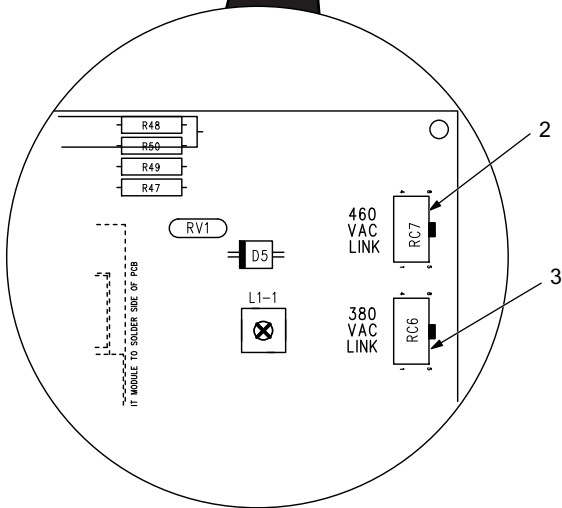
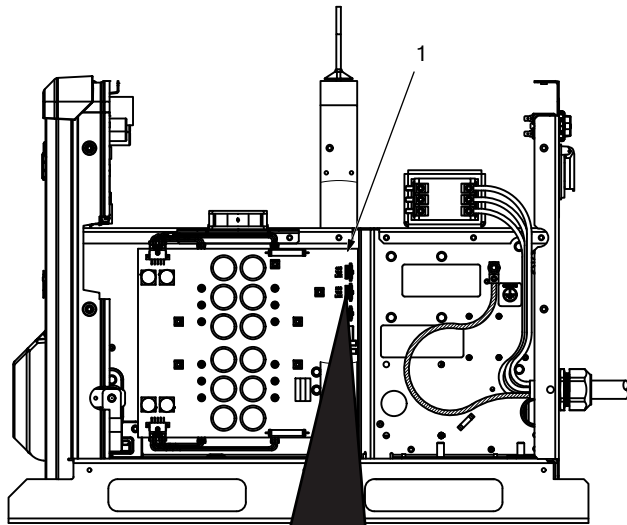
### 5-3. Selecting Input Voltage



-  Turn Off welding power source, and disconnect input power.
-  Significant DC voltage can remain on capacitors after unit is Off. Wait 5 minutes after input power has been disconnected to allow capacitors to discharge.

Check input voltage available at site.

Check voltage selected in unit. Changing selection is only necessary if selected value does not match input voltage.

- 1 Interconnect Board PC2
- 2 Receptacle RC7 (Connection For 460 VAC Input Power) (460 VAC Link)
- 3 Receptacle RC6 (Connection For 380 VAC Input Power) (380 VAC Link)

To change voltage selection, move relinking plug PLG7 on PC2 to match input power voltage.

## 5-4. Weld Output Terminals

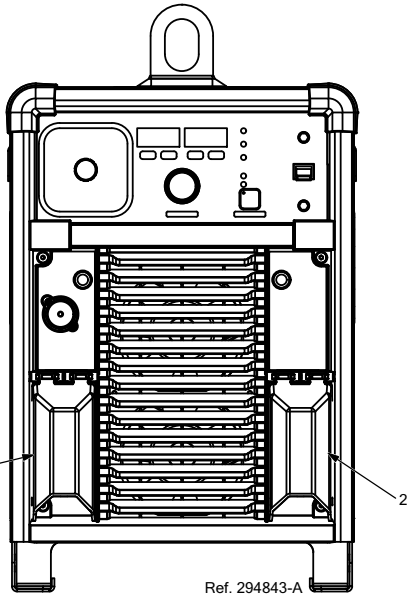

**⚠ Turn off power before connecting to weld output terminals.**

**⚠ Do not use worn, damaged, undersized, or repaired cables.**

1 Electrode - Weld Output Terminal

2 Work - Weld Output Terminal

☞ See Section 5-5 for information on connecting to weld output terminals, and Sections 7-1 thru 8-3 for standard connection diagrams.

## 5-5. Connecting Weld Output Cables

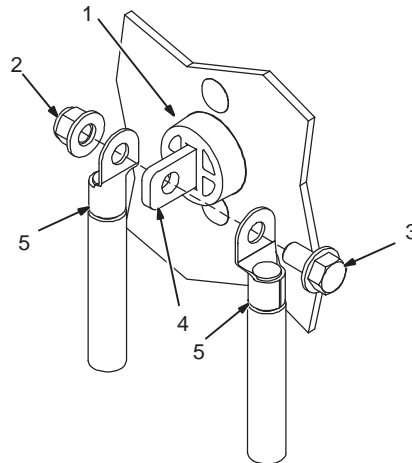

269322-A

**⚠ Turn off power before connecting to weld output terminals.**

**⚠ Failure to properly connect weld cables may cause excessive heat and start a fire, or damage your machine.**

**⚠ Use correct size weld cables (see Section 5-2).**

1 Weld Output Terminal

2 Supplied Weld Output Terminal Nut

3 Supplied Weld Output Terminal Bolt

4 Copper Bar

5 Weld Cable Terminal

Remove supplied bolt and nut from weld output terminal. Secure weld cable terminals to weld output terminal with nut and bolt as

shown, so that weld cable terminal is tight against copper bar.

**⚠ Do not place anything between weld cable terminal and copper bar. Make sure that the surfaces of the weld cable terminal and copper bar are clean.**

## 5-6. Remote 14 Receptacle Information

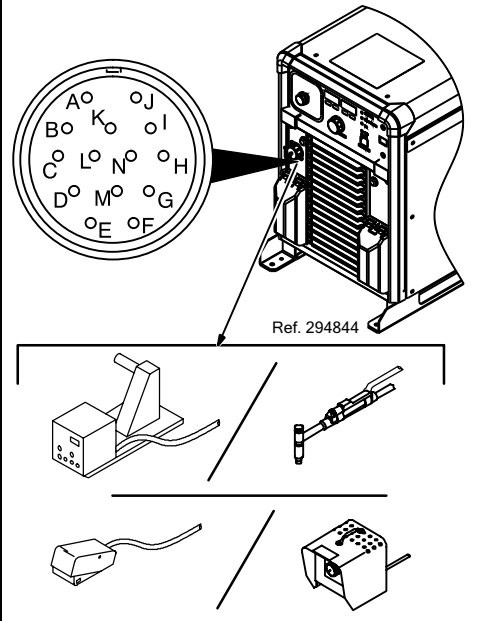
Remote 14	Socket*	Socket Information	
	A	Contactor control +15 volts DC.	
	Output (Contactor)	B	Contact closure to A completes 15 volts DC contactor control circuit and enables weld output.
	Remote Control	C	Output to remote control; +10 volts DC.
		D	Remote control circuit common.
		E	0 to +10 volts DC input command signal from remote control.
*The remaining sockets are not used.			

## 5-7. Electrical Service Guide

**⚠** Failure to follow these electrical service guide recommendations could create an electric shock or fire hazard. These recommendations are for an individual branch circuit sized for the rated output and duty cycle of one welding power source. In individual branch circuit installations, the National Electrical Code (NEC) allows the receptacle or conductor rating to be less than the rating of the circuit protection device. All components of the circuit must be physically compatible. See NEC articles 210.21, 630.11, and 630.12.

**NOTICE** – *INCORRECT INPUT POWER can damage this welding power source. This welding power source requires a CONTINUOUS supply of input power at rated frequency  $\pm 10\%$  and voltage  $\pm 10\%$ . Phase to ground voltage shall not exceed +10% of rated input voltage. Do not use a generator with automatic idle device (that idles engine when no load is sensed) to supply input power to this welding power source.*

**NOTICE** – *Actual input voltage should not be 10% less than minimum and/or 10% more than maximum input voltages listed in table. If actual input voltage is outside this range, output may not be available.*

	50 Hz 3-Phase	60 Hz 3-Phase
<b>Rated Supply Voltage (V)</b>	380	460
<b>Rated Maximum Supply Current <math>I_{1max}</math> (A)</b>	66.4	55.1
<b>Rated Effective Supply Current <math>I_{1eff}</math> (A)</b>	51	43
<b>Maximum Recommended Standard Fuse Rating In Amperes<sup>1</sup></b>		
<b>Time Delay Fuses<sup>2</sup></b>	80	60
<b>Normal Operating Fuses<sup>3</sup></b>	90	80
<b>Maximum Recommended Supply Conductor Length In Feet (Meters)<sup>4</sup></b>	206 (63)	191 (58)
<b>Raceway Installation</b>		
<b>Minimum Supply Conductor Size In AWG (mm<sup>2</sup>)<sup>5</sup></b>	6 (16)	8 (10)
<b>Minimum Grounding Conductor Size In AWG (mm<sup>2</sup>)<sup>5</sup></b>	8 (10)	8 (10)
<b>Flexible Cord Installation</b>		
<b>Minimum Supply Conductor Size In AWG (mm<sup>2</sup>)<sup>6</sup></b>	4 (25)	6 (16)
<b>Minimum Outside Diameter Of Cord In Inches (mm)</b>	0.865	0.865
<b>Maximum Outside Diameter Of Cord In Inches (mm)</b>	1.260	1.260
<b>Recommended Strain Relief<sup>7</sup></b>	See Parts List	See Parts List

Reference: 2023 National Electrical Code (NEC) (including article 630)

1 If a circuit breaker is used in place of a fuse, choose a circuit breaker with time-current curves comparable to the recommended fuse.

2 "Time-Delay" fuses are UL class "RK5" . See UL 248.

3 "Normal Operating" (general purpose - no intentional delay) fuses are UL class "K5" (up to and including 60 amps), and UL class "H" ( 65 amps and above). See UL 248.

4 Maximum total length of copper supply conductors in entire installation, raceway and/or flexible cord.

5 Raceway conductor data in this section specifies conductor size (excluding flexible cord or cable) between the panelboard and the equipment per NEC Table 310.16 and is based on allowable ampacities of insulated copper conductors having a temperature rating of 75°C (167°F) with not more than three single current-carrying conductors in a raceway.

6 Flexible cord conductor size is based on NEC Table 400.5(A)(1) for SOOW 600V 90°C (194°F) jacketed cable in a 30°C (86°F) ambient temperature. See NEC Table 310.15(B)(1)(1) for ambient temperature correction factors. Flexible cord used for connection to the power supply system shall comply with the requirements of UL 62.

7 If necessary, have a qualified person enlarge access hole in machine panel to accommodate strain relief.

## 5-8. Connecting 3-Phase Input Power

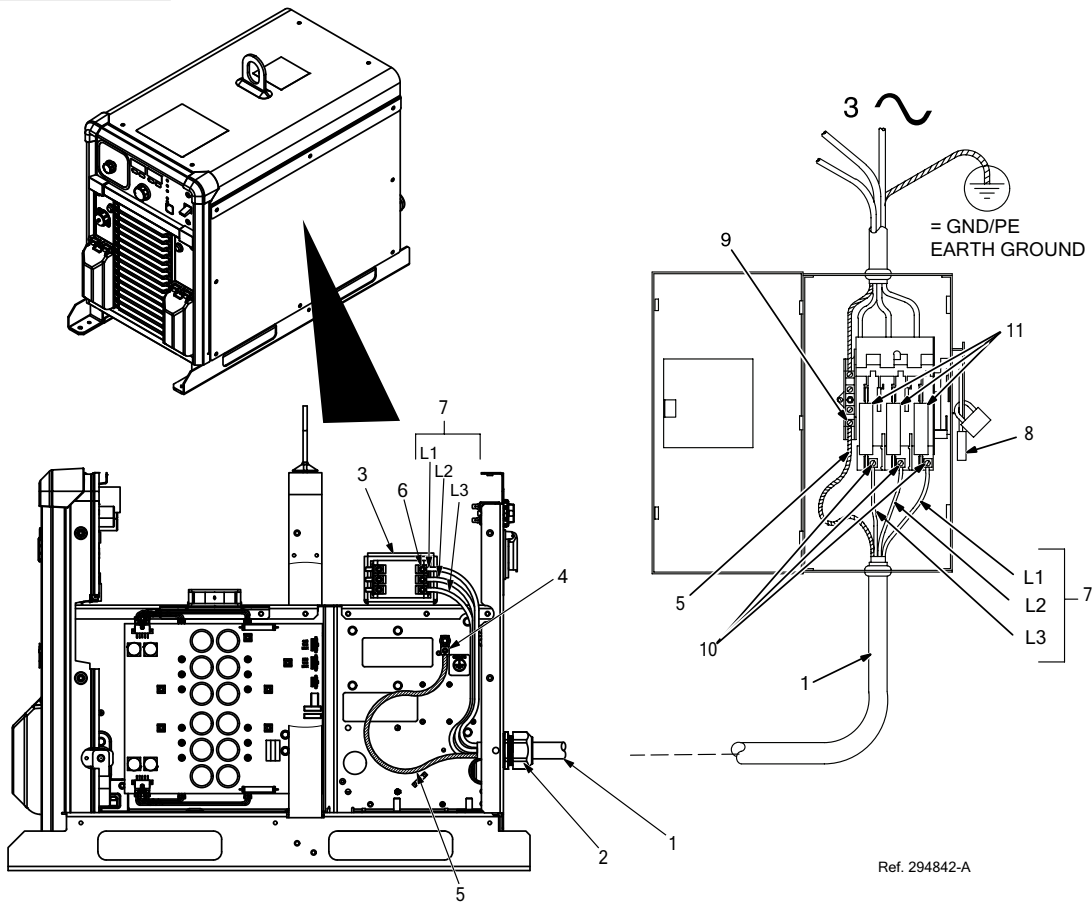

Ref. 294842-A



**⚠ Significant DC voltage can remain on capacitors after unit is Off. Always check the voltage as shown to be sure the input capacitors have discharged before working on unit.**

**⚠ Installation must meet all National and Local Codes—have only qualified persons make this installation.**

**⚠ Disconnect and lockout/tagout input power before connecting input conductors from unit. Follow established procedures regarding the installation and removal of lockout/tagout devices.**

**⚠ Make input power connections to the welding power source first.**

**⚠ Always connect green or green/yellow conductor to supply grounding terminal first, and never to a line terminal.**

See rating label on unit and check input voltage available at site.

1 Input Power Conductors (Customer Supplied Cord)

Select size and length of conductors using Electrical Service Guide. Conductors must

comply with national, state, and local electrical codes. If applicable, use lugs of proper amperage capacity and correct hole size.

### Welding Power Source Input Power Connections

2 Strain Relief Kit (Supplied With Machine)

Install strain relief as explained in instructions supplied with kit.

3 Contactor W1

4 Welding Power Source Grounding Terminal

5 Green Or Green/Yellow Grounding Conductor

Connect green or green/yellow grounding conductor to machine grounding terminal first.

6 Welding Power Source Line Terminals

7 Input Conductors (L1, L2, And L3)

Connect input conductors L1, L2, and L3 to welding power source line terminals.

Reinstall side panel on welding power source.

### Disconnect Device Input Power Connections

8 Disconnect Device (switch shown in the OFF position)

9 Disconnect Device Grounding Terminal

10 Disconnect Device Line Terminals

Connect green or green/yellow grounding conductor to disconnect device grounding terminal first.

Connect input conductors L1, L2, and L3 to disconnect device line terminals.

11 Over-Current Protection

Select type and size of over-current protection using Electrical Service Guide (fused disconnect switch shown).

Close and secure door on disconnect device. Follow established lockout/tagout procedures to put unit in service.

# SECTION 6 – GENERAL OPERATION

## 6-1. Front Panel

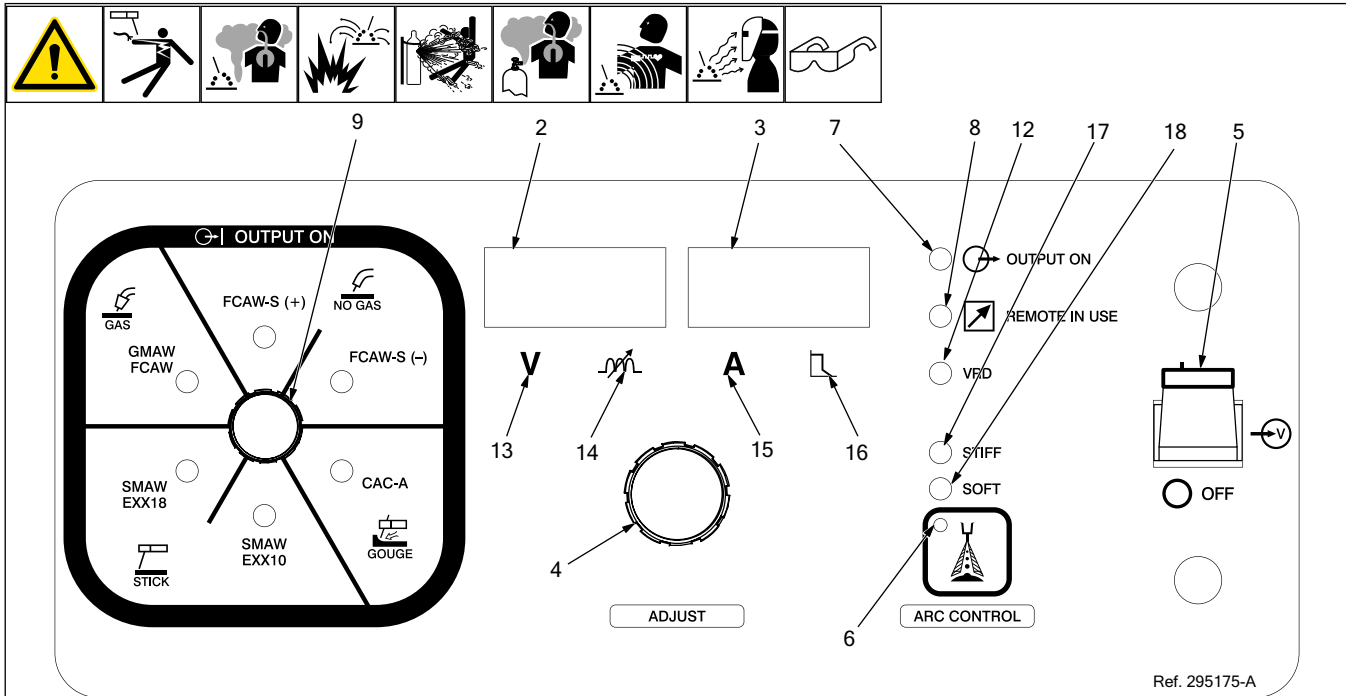

Ref. 295175-A

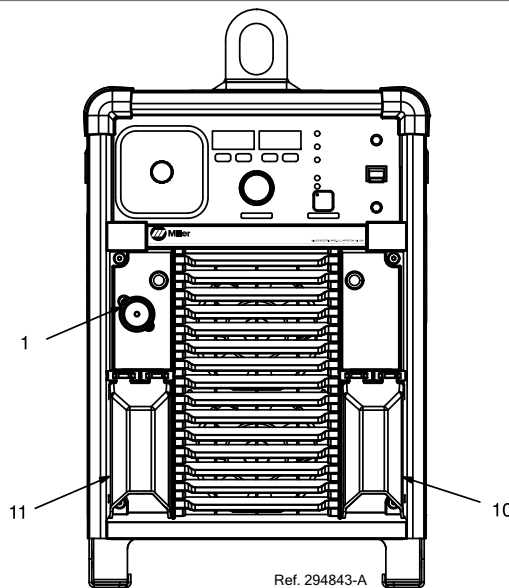

Ref. 294843-A





☞ Weld process operation sections describe functionality of the identified items (See Sections 7-1 thru 8-3).

- 1 Remote 14 Receptacle
- 2 Left Display
- 3 Right Display

☞ The meters display the actual weld output values after arc initiation and remains displayed for approximately three seconds after the arc is broken.

- 4 Adjust Control
- 5 Power Switch
- 6 Arc Control Button
- 7 Output On Indicator
- 8 Remote In Use Indicator
- 9 Mode Switch
- 10 Weld Output Terminal (-)
- 11 Weld Output Terminal (+)
- 12 VRD Indicator
- 13 Volt Indicator
- 14 Arc Control Indicator For Wire Modes
- 15 Amp Indicator
- 16 Arc Control Indicator For Stick Modes
- 17 Arc Control Stiff Indicator
- 18 Arc Control Soft Indicator

## 6-2. Mode Switch Settings

Switch Position	Process	Output Control	Panel Adjust	Remote Adjust <sup>1</sup>	Weld Terminal Polarity		
					Configura-tion <sup>2</sup>	Electrode	Work
	GMAW/FCAW Gas	Output On	Volts	No Remote Adjust	DCEP	Positive	Negative
	FCAW-S (+) No-Gas	Output On	Volts	No Remote Adjust	DCEP	Positive	Negative
	FCAW-S (-) No-Gas	Output On	Volts	No Remote Adjust	DCEN	Negative	Positive
	SMAW EXX10 Stick	Output On	Amps	% of Panel Amps	DCEP	Positive	Negative
	SMAW EXX18 Stick	Output On	Amps	% of Panel Amps	DCEP	Positive	Negative
	CAC-A Gouge	Output On	Amps	% of Panel Amps	DCEP	Positive	Negative

<sup>1</sup> An ArcReach device will override any remote control connected to remote 14 receptacle.

<sup>2</sup> The unit automatically configures the weld terminal polarity. DCEP = Direct Current Electrode Positive. Reverse Polarity; DCEN = Direct Current Electrode Negative — Straight Polarity.

## 6-3. Associating ArcReach Device To ArcReach Power Source

### Quick Setup Guide:

**Step 1.** Make connections between power source and ArcReach device. (See section pertaining to mode being used for typical connection diagrams).

**Step 2.** This power source has the ability to associate with an ArcReach device at power up. The Mode Switch on this power source must be set to an "OUTPUT ON" mode to associate with another ArcReach device.

**Step 3.** See instructions in the owner's manual for the specific ArcReach device to associate the device to this power source.

**Step 4.** During the association process the Remote In Use indicator will blink.

**Step 5.** When the association process is complete, the Remote In Use indicator will be lit and ACC will be displayed. Dependent on the capabilities of the ArcReach device; the mode switch, voltage/amperage adjustment, and Arc Control adjustment may be overridden by the ArcReach device.

**Step 6.** The association ends approximately 10 seconds after the ArcReach device is disconnected or turned off and the power source is not welding. After association has ended the Remote in Use indicator will turn off and control will revert back to panel operation.

## 6-4. Optional — Voltage Reducing Device (VRD) Mode

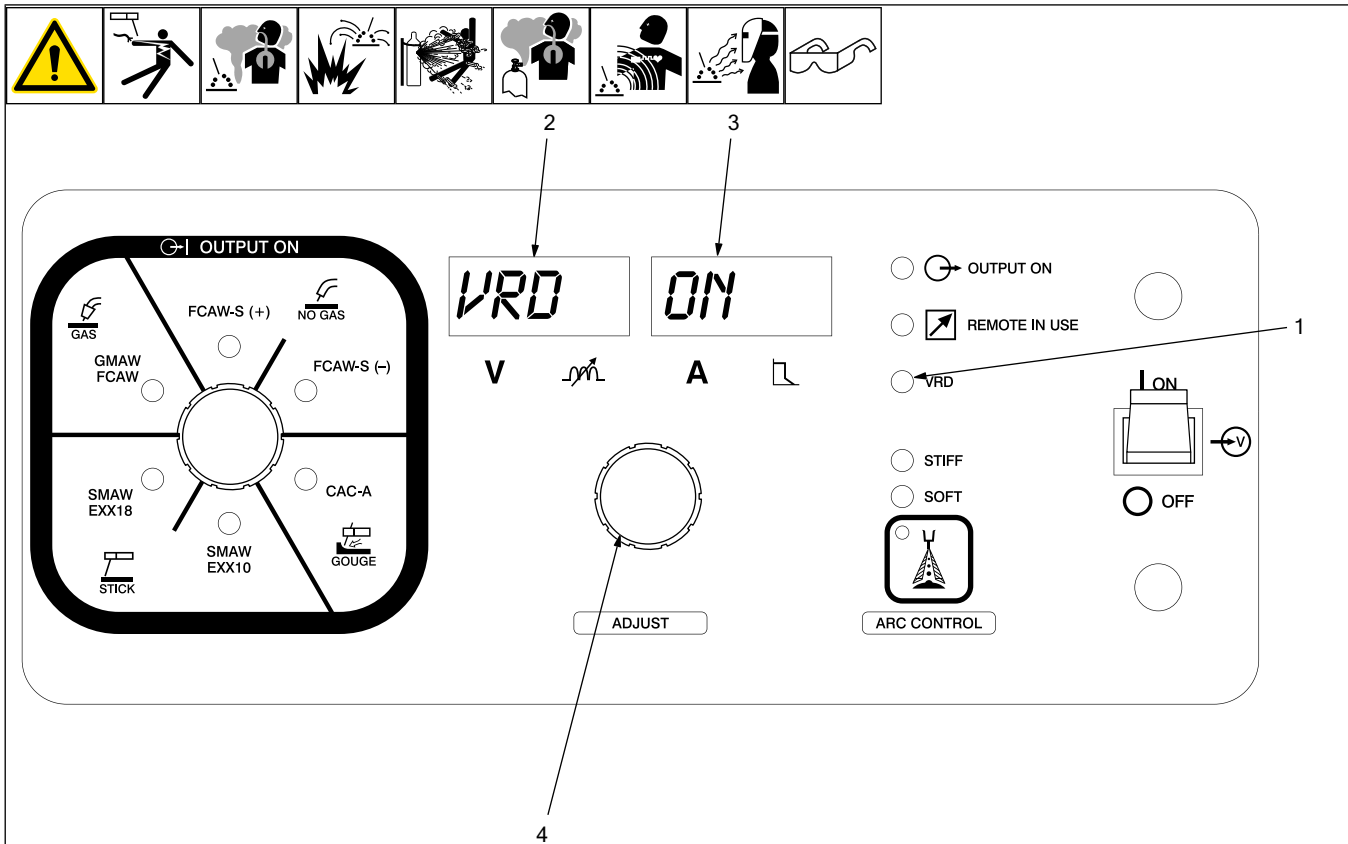

VRD can only be turned ON and OFF with USB when DIP SW1 is in the UP position. See 6-5 for more information.

Enabling Voltage-Reducing Device (VRD) mode configures the XMT 650 to operate in VRD mode using low Open Circuit Voltage (Low-OCV).

To enable the VRD Mode, visit [www.millerwelds.com/support/software](http://www.millerwelds.com/support/software) and select XMT 650 to download the software to a USB drive.

- 1 VRD Indicator
- 2 Left Display
- 3 Right Display
- 4 Adjust Control

**Step 1.** Insert flash drive into the USB port on rear panel.

**Step 2.** Power unit ON.

**Step 3.** When machine displays 'VRD' move the Adjust Knob to select option 'ON' or 'OFF'.

**Step 4.** Remove the flash drive and machine resumes starting up.

**The VRD feature is now configured for use.**

## 6-5. Activating Optional Voltage Reducing Device (VRD) with DIP Switch

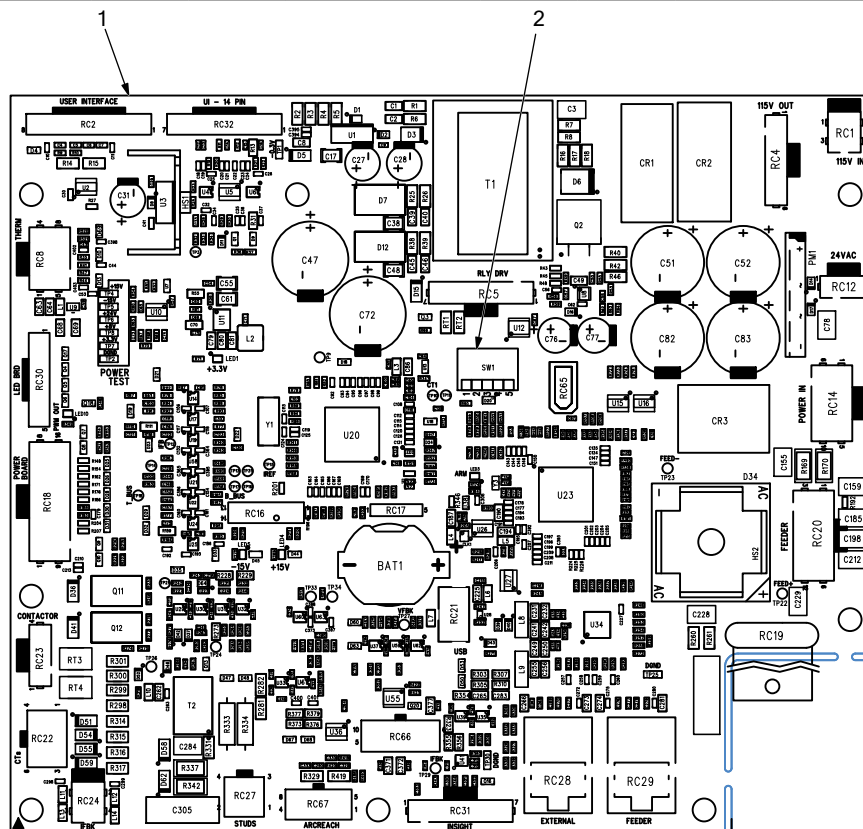

**⚠** Turn Off welding power source, and disconnect input power.

**⚠** Significant DC voltage can remain on capacitors after unit is Off. Wait 5 minutes after input power has been disconnected to allow capacitors to discharge.

VRD can be activated with SW1 when activation with a USB is not possible. Once VRD is activated using SW1 it can no longer be configured ON or OFF using the USB. See table below for more details.

VRD Table		
DIP SW	USB VRD	VRD
Up	Off	Off
Down	Off	On
Up	On	On
Down	On	On

- 1 Control Board PC1
- 2 Dip Switch

Remove power source cover.

Set Dip Switch SW1 Pin 1 to the down position to turn VRD ON or set Dip Switch SW1 to the up position to turn VRD OFF (Default Position).

Reinstall power source cover.

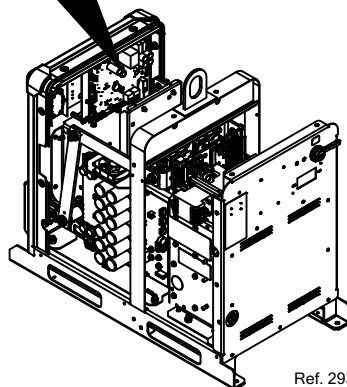

Ref. 293014-A/288852-D

## 6-6. Alternate Configuration Functions

The Function of the remote control and panel meters can be changed on this machine.

To view or change the active configuration:

- Place the process selection switch into SMAW (Stick) Output-on mode.
- Quickly tap (press and release) the wire feeder gun trigger or remote output on–off switch 3 to 5 times within a few seconds to view the active configuration.
- Repeat the tapping sequence to switch to the next configuration. The right meter will briefly display the new configuration before returning to the preset display.

☞ *Do not turn power off for at least 5 seconds to ensure the new configuration is saved. If supported, Preflow must be disabled on the wire feeder to recognize gun trigger taps.*

Alternate configurations are explained below. See section 8-1 for default configuration operation.

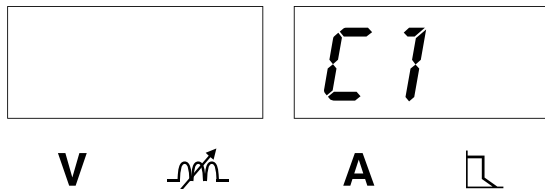

C1 mode is the factory default setting. If a Remote device is plugged in, Auto Remote detect will give the remote control in all processes.

A remote can be a wire feeder, foot pedal, or hand control.

**SMAW EXX18 (Stick), SMAW EXX10 (Stick) and CAC-A (Gouge):**  
The right meter displays the preset amperage set with the panel Adjust Control. When connected, the remote control sets the percentage of preset amperage. The Remote In Use indicator is lit while the remote control is connected.

## 6-7. Updating Software

**Step 1.** Visit [www.millerwelds.com/support/software](http://www.millerwelds.com/support/software) and select XMT 650.

**Step 2.** Open Installation Instructions and follow

**Step 3.** The latest software updates can be found in Download Software Updates.

**NOTICE** – A power cycle must be performed after every software update.

## 6-8. Obtaining Service.TXT file

☞ *SERVICE.TXT file is a text file containing all current part numbers of the system and diagnostic information.*

### Service File Instructions

**Step 1.** With power source OFF, plug in USB flash drive to the USB port of the power source.

**Step 2.** Turn power source ON

**Step 3.** A SERVICE.TXT file is automatically generated on the USB flash drive when the power source is turned ON.

**Step 4.** Remove USB flash drive from the power source.

**Step 5.** System and diagnostic information are now available for viewing when opening SERVICE.TXT file on a computer.

# SECTION 7 – GMAW/FCAW OPERATION

## 7-1. Typical Connection For Voltage-Sensing Feeder GMAW/FCAW Process

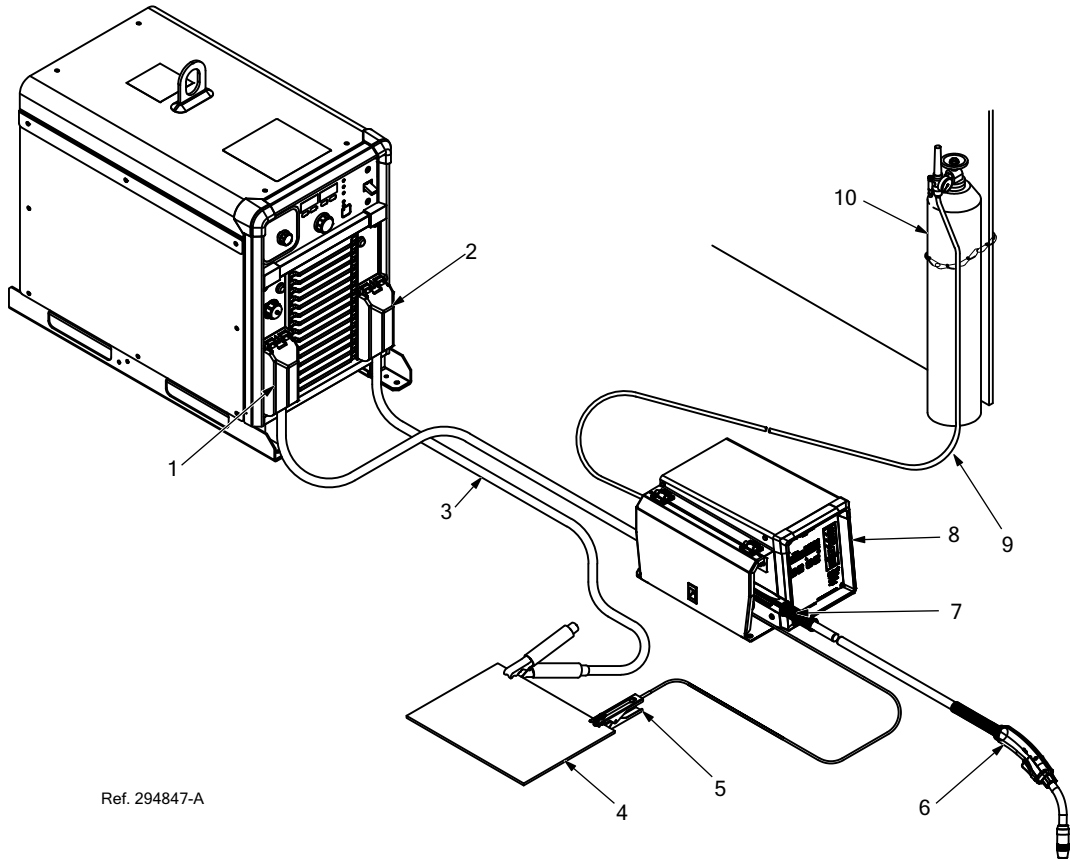
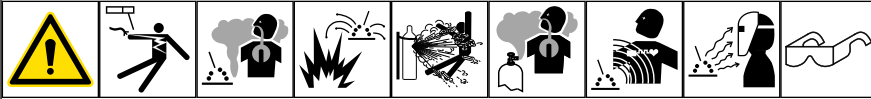

Ref. 294847-A

**⚠ Turn off power before making connections.**

- 1 Positive (+) Weld Output Terminal
- 2 Negative (-) Weld Output Terminal
- 3 Ground Cable to Workpiece
- 4 Workpiece
- 5 Voltage Sensing Clamp

- 6 Gun
- 7 Gun Trigger Receptacle
- 8 Wire Feeder
- 9 Gas Hose
- 10 Gas Cylinder

Use of shielding gas is dependant on Wire Type.

*☞ The connection diagram illustrates DCEP (reverse polarity) suitable for all wires except self-shielded FCAW. The majority of self-shielded FCAW wires require DCEN (straight polarity).*

## 7-2. GMAW/FCAW - (Gas) Or FCAW-S (No Gas) Output-On Welding Modes

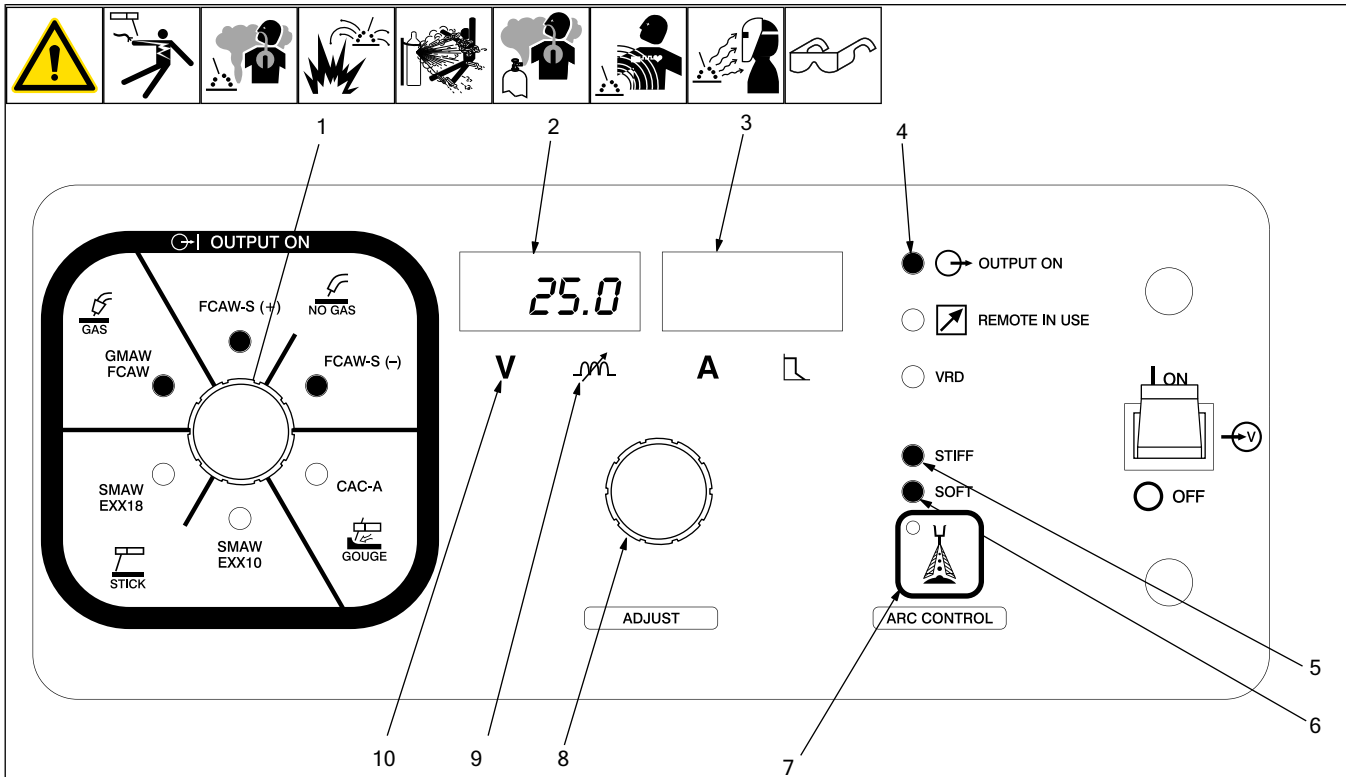

**⚠** Weld terminals are energized at all times in GMAW/FCAW (Gas) and FCAW-S (No Gas) Output On welding modes.

- 1 Mode Select
- 2 Left Meter Display
- 3 Right Display
- 4 Output On Indicator
- 5 Arc Control Stiff Indicator
- 6 Arc Control Soft Indicator
- 7 Arc Control Button
- 8 Adjust Control
- 9 Arc Control Indicator For Wire Modes
- 10 Volts Indicator

### Setup

For typical system setup connections refer to Section 7-1.

Rotate Mode switch to GMAW/FCAW (Gas) or FCAW-S (No Gas) Output On position as shown.

The Left display toggles between actual voltage and preset arc voltage with the Volts indicator lit. The Output On indicator will be lit.

*☞ If associated to an ArcReach feeder with Cable Length Compensation the voltage display on the power source will show ACC.*

### Operation

While the Volts indicator is lit under the Left display, the Adjust control is used to set desired preset voltage.

*☞ The Left display toggling momentarily pauses while the preset voltage is adjusted.*

*☞ If an ArcReach device is used for voltage adjustment, it will have the full range of the preset voltage. Dependent on the capabilities of the device, it may have the ability to override parameter adjustments and mode switch setting. The Remote In Use indicator will be lit. An ArcReach device will override a remote control connected to the Remote 14 Receptacle.*

*☞ If using an ArcReach feeder capable of communication while welding, the voltage can be adjusted while welding.*

### Arc Control

Pressing the Arc Control button allows adjustment of Arc Control settings.

Pressing the Arc Control button will cause the Arc Control indicator to light. Dependent on the setting: the STIFF or SOFT indicator will light and STIF or SOFT will appear on the Left display. 0 to 25 will appear on the Right display. If set to 0 neither STIF or SOFT will appear.

Rotate Adjust control to select desired Arc Control setting from 0 to 25 Soft and 0 to 25 Stiff. Minimum Arc Control setting is Soft 25. Maximum Arc Control setting is Stiff 25. Mid-range adjustment of 0 is good for most applications. Use lower Arc Control settings to stiffen the arc and reduce puddle fluidity. Use higher Arc Control settings to soften the arc and increase puddle fluidity.

After three seconds of inactivity the Adjust Control will revert back to adjusting preset voltage.

# SECTION 8 – SMAW/CAC-A OPERATION

## 8-1. Typical Connection For SMAW And CAC-A Process

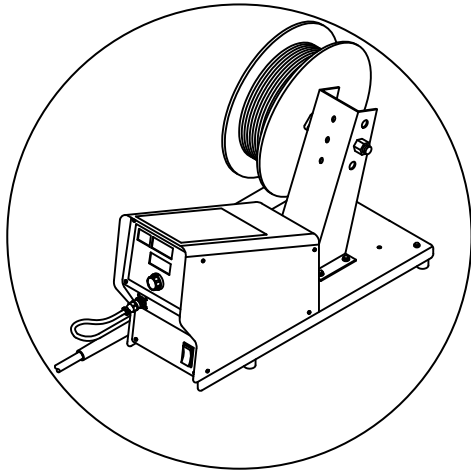

If a wire feeder is plugged into the remote, it may require a configuration change to achieve desired functionality. See Section 6-6.

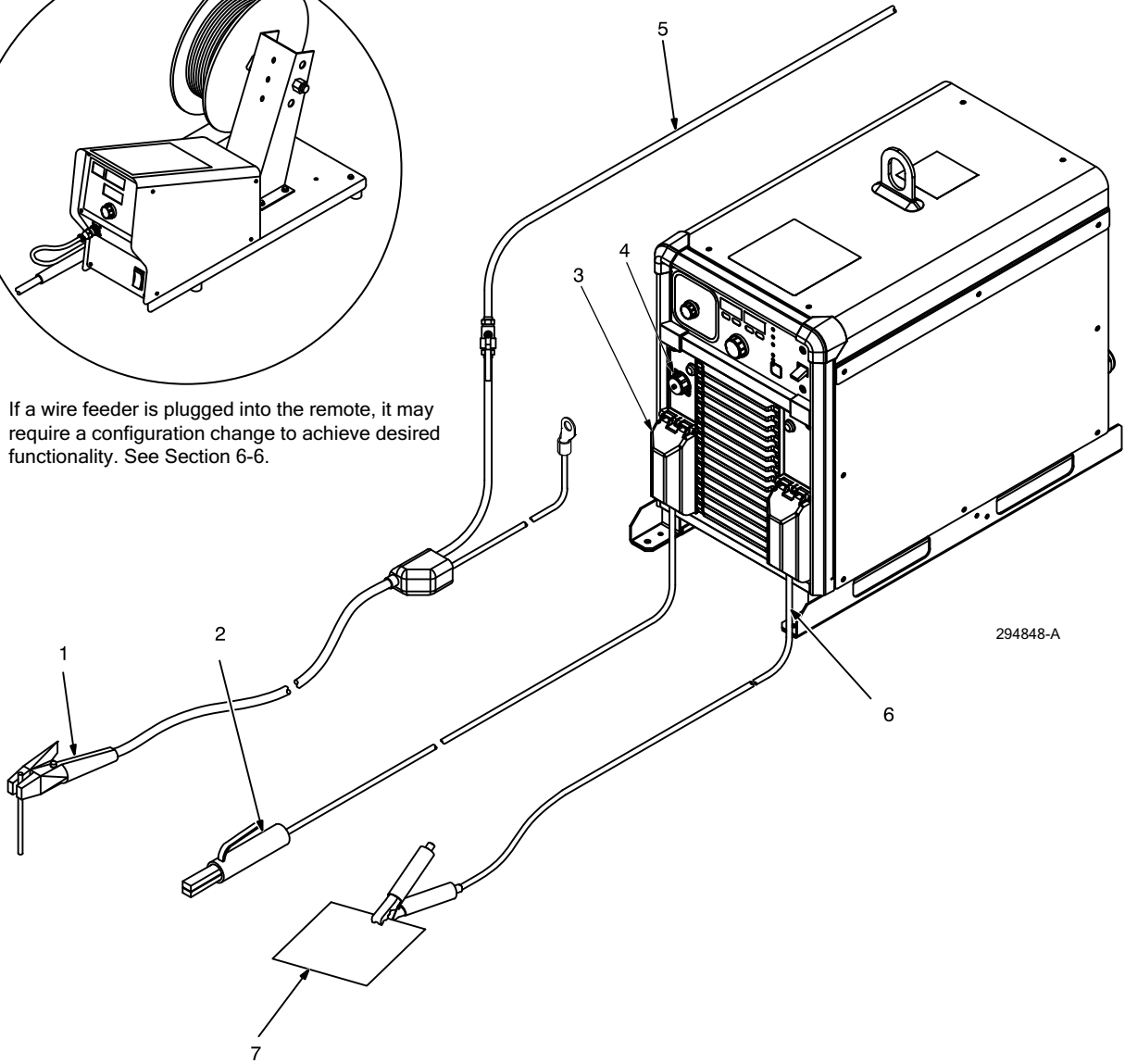

**⚠ Turn off power before making connections.**

1 Electrode Holder (Carbon Arc)

For CAC-A process connect carbon arc cutting torch to positive weld output terminal.

2 Electrode Holder

3 Positive (+) Weld Output Terminal

4 Remote 14 Receptacle

Connect desired remote control to remote 14 receptacle as required.

5 Compressed Air Line

6 Negative (-) Weld Output Terminal

7 Workpiece

294848-A

## 8-2. SMAW—Stick Output On Welding Mode

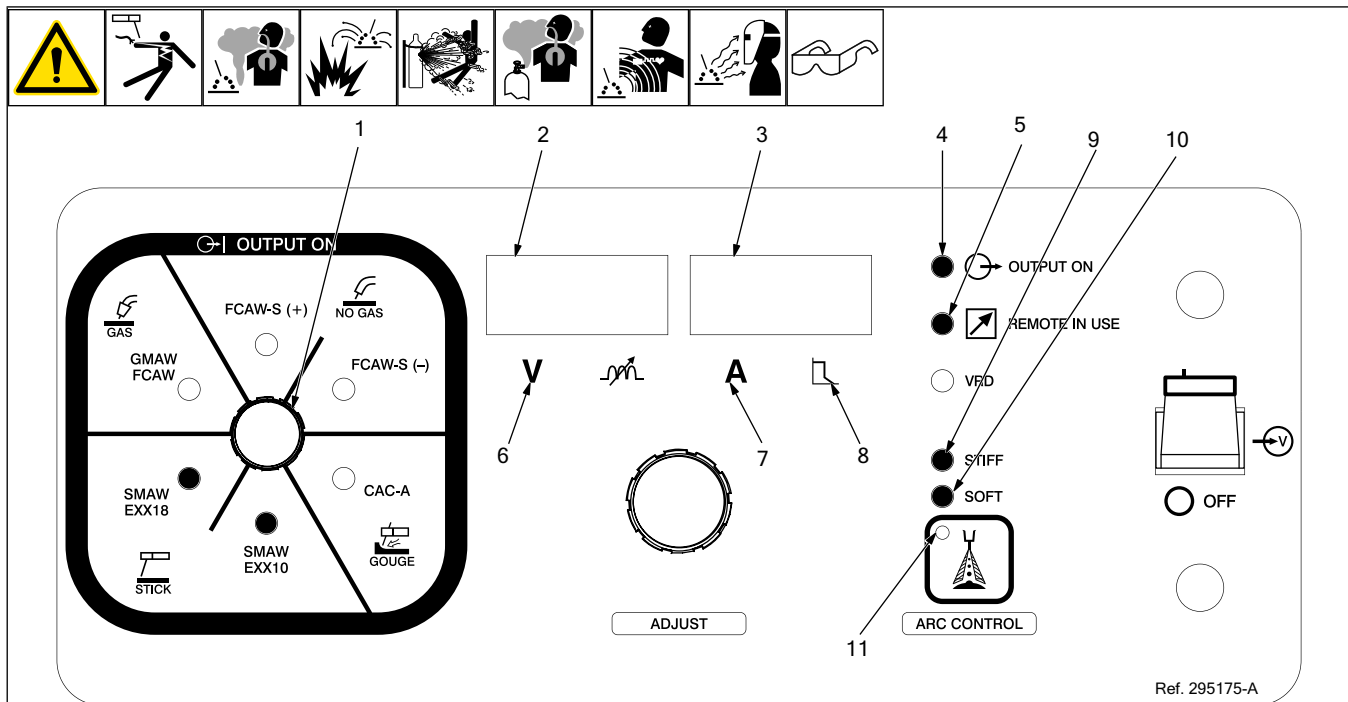

Ref. 295175-A

**⚠ Weld terminals are energized at all times in SMAW - Stick Output-On welding mode.**

- 1 Mode Select
- 2 Left Meter Display
- 3 Right Meter Display
- 4 Output On Indicator
- 5 Remote In Use Indicator
- 6 Volt Indicator
- 7 Amp Indicator
- 8 Arc Control Indicator For Stick Modes
- 9 Arc Control Stiff Indicator
- 10 Arc Control Soft Indicator
- 11 Arc Control Button

### Setup

For typical system connections refer to Section 8-1.

Rotate Mode Switch to SMAW EXX18 or SMAW EXX10 - Stick position as shown.

The preset amperage is shown in the right display with the Amp indicator lit. The Output On indicator will be lit.

### Operation

When the Amps indicator is lit under the right display, the Adjust control is used to set desired preset amperage.

Pressing the Arc Control button allows adjustment of Arc Control and Programmable Host Start Settings.

### Hot Start Settings

Adaptive Hot Start automatically increases welding amperage at the start of a weld. This helps eliminate electrode sticking during arc initiation.

*☞ If a remote control is connected to the Remote 14 receptacle and used for amperage adjustment, the adjustment will function as a percentage of the preset amperage. The Remote In Use indicator will be lit.*

*☞ If an ArcReach device is used for amperage adjustment, it will have full range of the preset amperage. If using an ArcReach device capable of communication while welding, the amperage can be adjusted while welding. Dependent on the capabilities of the device, it may have the ability to override parameter adjustments and mode switch setting. The Remote In Use indicator will be lit. An ArcReach device will override a remote control connected to the Remote 14 Receptacle.*

*☞ For best results at the end of the weld, pull back the electrode quickly to extinguish the arc.*

*☞ See Section 8-1 for information regarding alternate configurations.*

### Arc Control

Pressing the Arc Control button allows adjustment of Arc Control settings.

Pressing the Arc Control button will cause the Arc Control indicator to light. Dependent on the setting: the STIFF or SOFT indicator will light and STIF or SOFT will appear on the left display. 0 to 25 will appear on the right display. If set to 0 neither STIF or SOFT will appear.

Rotate Adjust control to select desired Arc Control setting from 0 to 25 Soft and 0 to 25 Stiff. Minimum Arc Control setting is Soft 25. Maximum Arc Control setting is Stiff 25. Mid-range adjustment of 0 is good for most applications.

Arc Control allows the arc characteristics, soft versus stiff, to be changed for specific applications and electrodes. Lower the Arc Control setting for smooth running electrodes like E7018 and increase the Arc Control setting for stiffer, more penetrating electrodes like E6010.

After three seconds of inactivity, the Adjust control will revert back to adjusting preset amperage.

*☞ While in Air Carbon Arc (CAC-A) mode, Arc Control is not adjustable.*

### 8-3. CAC-A—Gouge Output On Mode

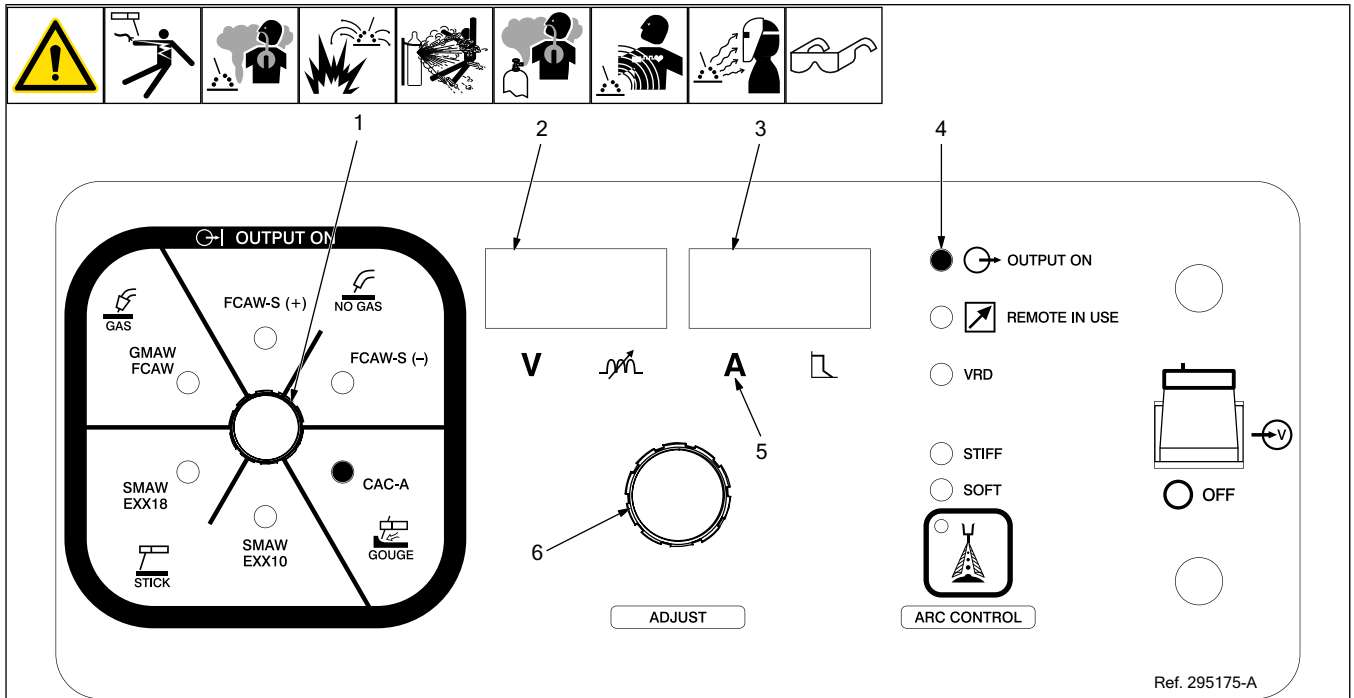

Ref. 295175-A

**⚠ Weld terminals are energized at all times in CAC-A - Gouge Output-On welding mode.**

- 1 Mode Switch
- 2 Left Meter Display
- 3 Right Meter Display
- 4 Output On Indicator
- 5 Amp Indicator
- 6 Adjust Control

**Setup**

For typical system connections refer to Section 8-1.

Rotate Mode switch to CAC-A-Gouge Output On position as shown.

The open circuit voltage is shown in the left display and the preset amperage is shown in the right display with the Amp indicator lit. The Output On indicator will be lit.

**Operation**

The Adjust control is used to set desired pre-set amperage.

*⚠ If an ArcReach device is used for amperage adjustment, it will have full range of the preset amperage. Dependent on the capabilities of the device, it may have the ability to override parameter adjustments and mode switch setting. The Remote In Use indicator will be lit. An ArcReach device will override a remote control connected to the Remote 14 Receptacle.*

*⚠ While in Air Carbon Arc (CAC-A) mode, Arc Control is not adjustable.*

# SECTION 9 – MAINTENANCE AND TROUBLESHOOTING

## 9-1. Routine Maintenance

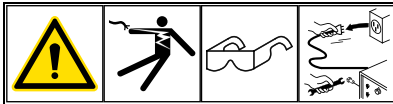

**⚠ Disconnect power before maintaining.**

*👉 Maintain more often during severe conditions.*

🕒	✓ = Check	◇ = Change	○ = Clean	☆ = Replace
Every 3 Months	<p>☆ Damaged or unreadable labels</p>	<p>☆ Cracked cables and cords</p>	<p>☆ Cracked torch body</p>	
	<p>○ Clean and tighten weld connections</p>			
Every 6 Months	<p>○ Inside of unit</p>			

## 9-2. Blowing Out Inside Of Unit

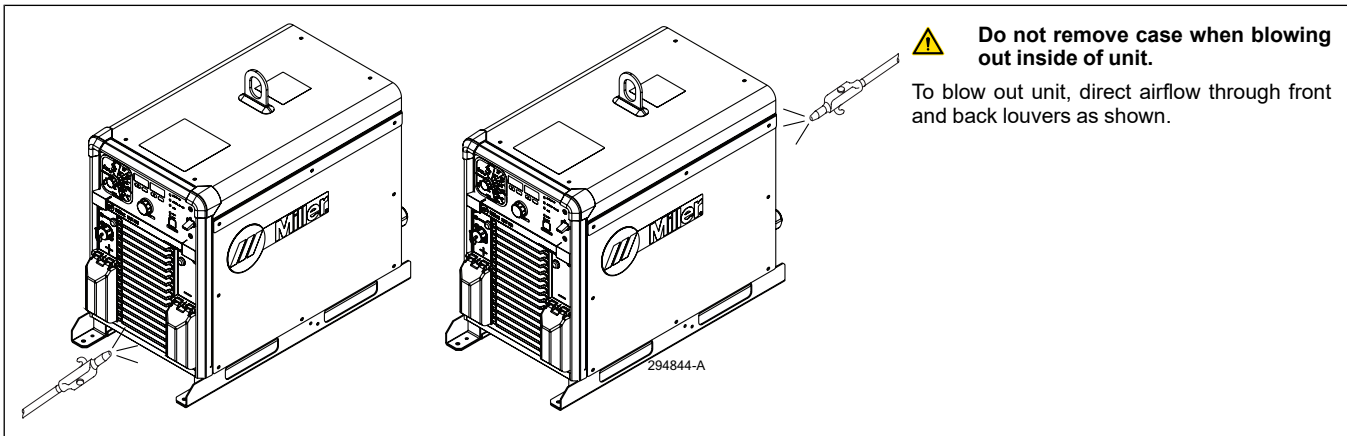



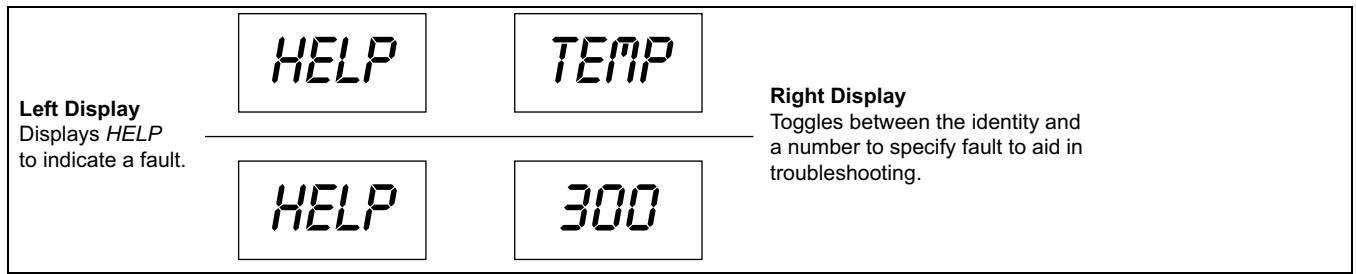

### 9-3. Fault Code Diagnostics



Unit Display Toggles Message		Description
<i>HELP IN</i>	<i>HELP 1 XX</i>	Indicates a malfunction in the primary power circuit. If this display is shown, contact a Factory Authorized Service Agent.
<i>HELP TEMP</i>	<i>HELP 2 XX</i>	Indicates a malfunction in the thermal protection circuitry. If this display is shown, contact a Factory Authorized Service Agent.
<i>HELP TEMP</i>	<i>HELP 3 XX</i>	Indicates the left side (secondary) of the unit has overheated. The unit has shut down to allow the fan to cool it (see Section 4-9). Operation will continue when the unit has cooled.
<i>HELP TEMP</i>	<i>HELP 4 XX</i>	Indicates the auxiliary circuit has overheated. The unit has shut down to allow the fan to cool it. Operation will continue when the unit has cooled.
<i>HELP TEMP</i>	<i>HELP 5 XX</i>	Indicates the right side (primary) of the unit has overheated. The unit has shut down to allow the fan to cool it (see Section 4-9). Operation will continue when the unit has cooled.
<i>HELP LINE</i>	<i>HELP 6 XX</i>	Indicates machine has sensed a primary power circuit fault. Turn off unit for five minutes and try again. Verify correct primary voltage (See Section 5-8). If fault remains, contact a Factory Authorized Service Agent.
<i>HELP LINE</i>	<i>HELP 7 XX</i>	
<i>HELP OUT</i>	<i>HELP 8 XX</i>	Indicates a malfunction in the secondary power circuit of the unit. Verify electrode is not touching work piece when in Gouge or Stick modes. Check external weld circuit configuration of multiple power sources connected to the common work piece. Repair as necessary. If fault remains, contact a Factory Authorized Service Agent.
<i>HELP POL</i>	<i>HELP 23 XX</i>	
<i>HELP DUTY</i>	<i>HELP 25 XX</i>	Indicates machine has reached Duty Cycle limit (See Section 4-9). Unit must be left on to power the fan for cooling. Duty Cycle limit will automatically reset when unit has cooled.
<i>HELP TEMP</i>	<i>HELP 12XX</i>	Indicates the polarity reversing circuitry has overheated. The unit has shutdown to allow cooling. If problem persists, contact a Factory Authorized Service Agent.
<i>HELP XXXX</i>	<i>HELP XXXX</i>	Other Codes — Consult a Factory Authorized Service Agent..

The last two digits in the right display (shown with *XX* in the table) will indicate a specific fault a Factory Authorized Service Agent can use to troubleshoot the machine.

## 9-4. Troubleshooting

    				
Trouble		Remedy		
No weld output; unit completely inoperative.	Place line disconnect switch in On position (see Section 5-8).			
	Check and replace line fuse(s), if necessary, or reset circuit breaker (see Section 5-8).			
	Check for proper input power connections (see Section 5-8).			
No weld output; meter display On.	Input voltage outside acceptable range of variation (see Section 5-7).			
	Check, repair, or replace remote control.			
	Unit overheated. Allow unit to cool with fan On (see Section 4-9).			
Erratic or improper weld output.	Use proper size and type of weld cable (see Section 5-2).			
	Clean and tighten all weld connections.			
	Check for correct polarity.			

# SECTION 10 – ELECTRICAL DIAGRAMS

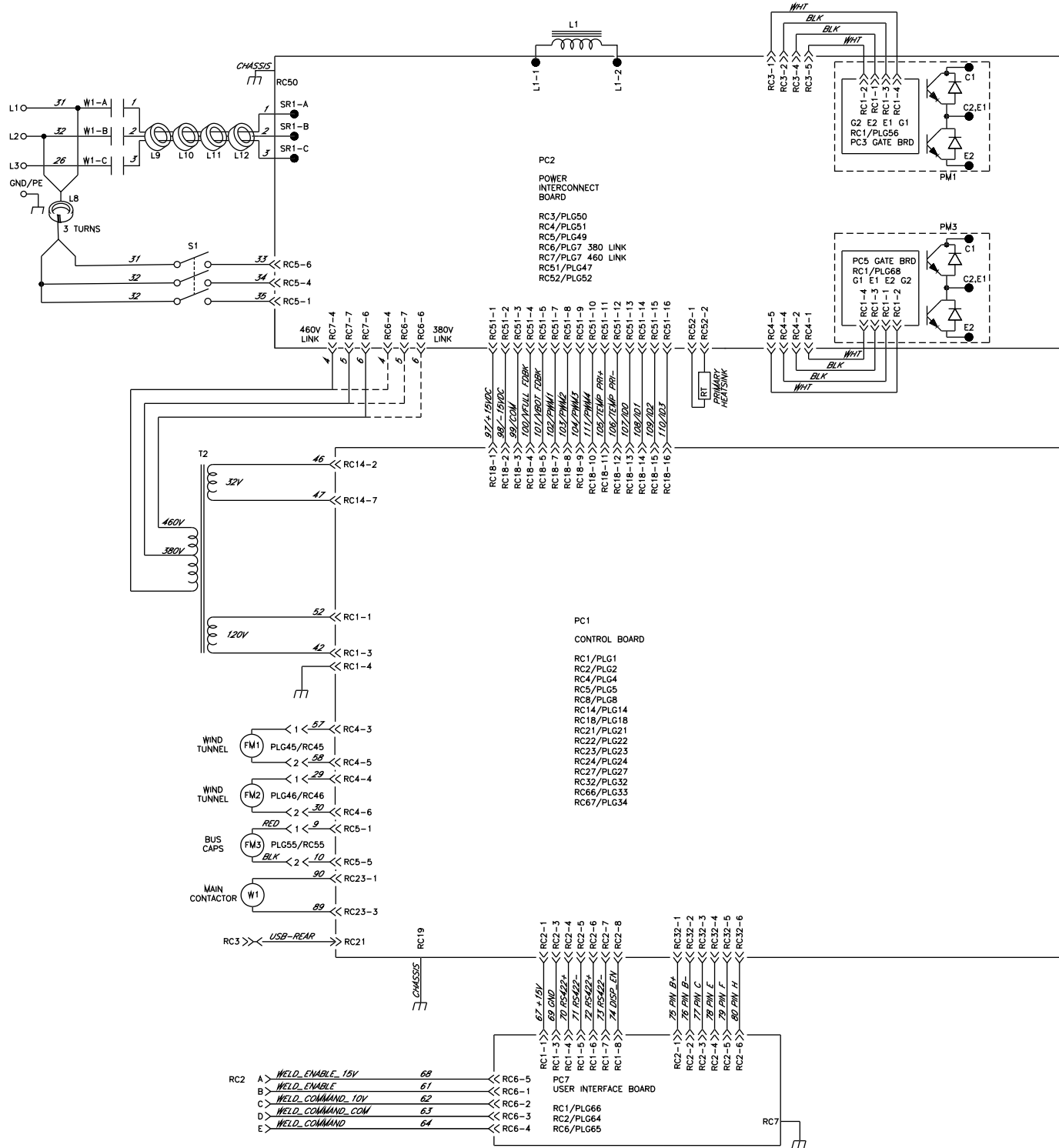
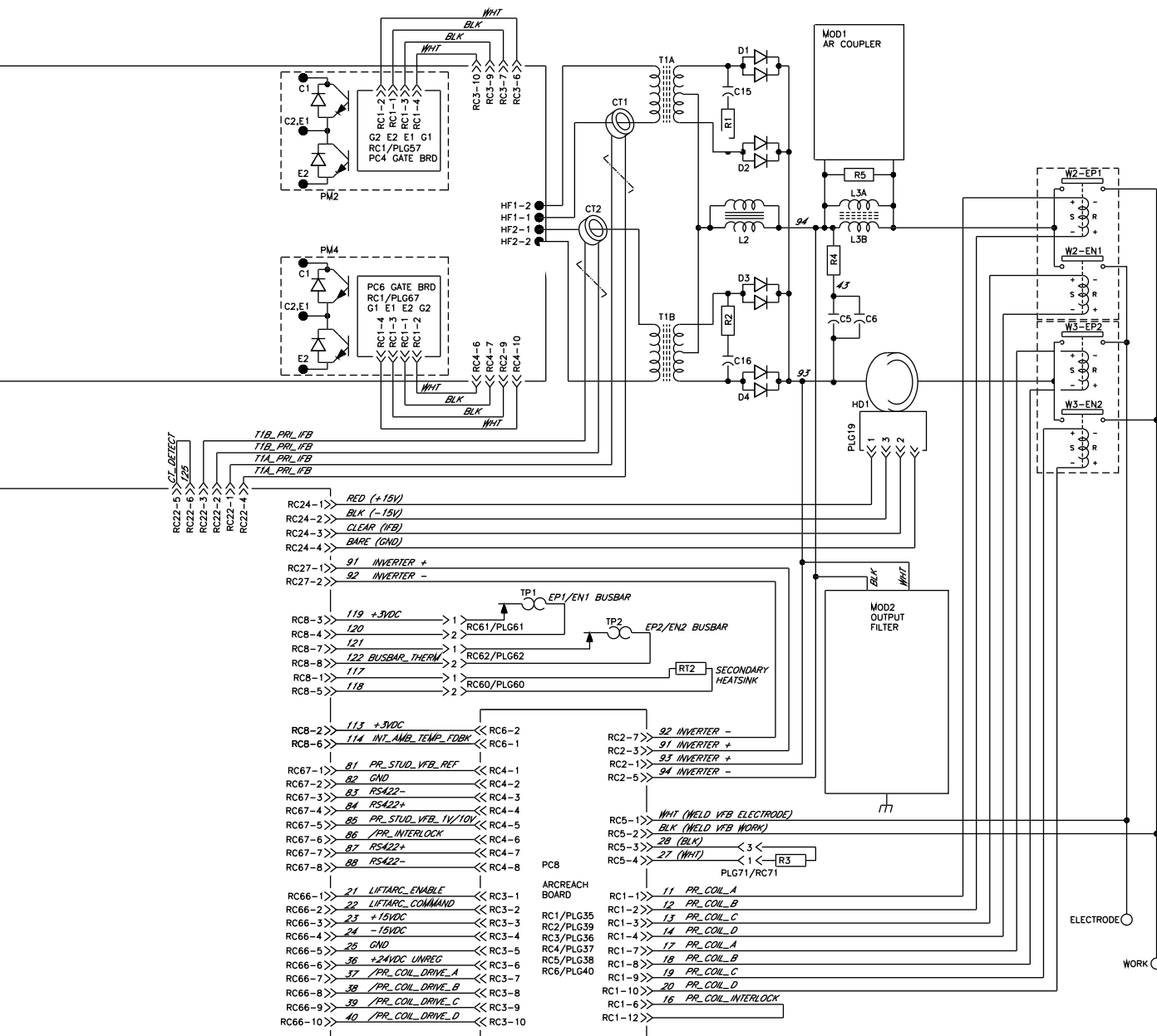



Figure 10-1. Circuit Diagram



 <b>WARNING</b> <b>ELECTRIC SHOCK HAZARD</b>	<ul style="list-style-type: none"> <li>Do not touch live electrical parts.</li> <li>Disconnect input power or stop engine before servicing.</li> <li>Do not operate with covers removed.</li> <li>Have only qualified persons install, use, or service this unit.</li> </ul>
--	--

Ref. 294957-A







# TRUE BLUE<sup>®</sup>

## WARRANTY



Effective January 1, 2024 (Equipment with a serial number preface of NE or newer)

This limited warranty supersedes all previous Miller warranties and is exclusive with no other guarantees or warranties expressed or implied.

**LIMITED WARRANTY** - Subject to the terms and conditions below, Miller Electric Mfg. LLC, Appleton, Wisconsin, warrants to authorized distributors that new Miller equipment sold after the effective date of this limited warranty is free of defects in material and workmanship at the time it is shipped by Miller. **THIS WARRANTY IS EXPRESSLY IN LIEU OF ALL OTHER WARRANTIES, EXPRESS OR IMPLIED, INCLUDING THE WARRANTIES OF MERCHANTABILITY AND FITNESS.**

Within the warranty periods listed below, Miller will repair or replace any warranted parts or components that fail due to such defects in material or workmanship. Notifications submitted as online warranty claims must provide detailed descriptions of the fault and troubleshooting steps taken to diagnose failed parts. Warranty claims that lack the required information as defined in the Miller Service Operation Guide (SOG) may be denied by Miller.

Miller shall honor warranty claims on warranted equipment listed below in the event of a defect within the warranty coverage time periods listed below. Warranty time periods start on the delivery date of the equipment to the end-user purchaser.

#### 1 5 Years Parts — 3 Years Labor

- Original Main Power Rectifiers Only to Include SCRs, Diodes, and Discrete Rectifier Modules in non-inverter products

#### 2 4 Years Parts (No Labor)

- Auto-Darkening ClearLight 2.0 Helmet Lenses

#### 3 3 Years — Parts and Labor Unless Specified

- Auto-Darkening Helmet Lenses (No Labor)
- Copilot Collaborative Welding Systems
- Engine Driven Welder/Generators (Including EnPak) **(NOTE: Engines are Warranted Separately by the Engine Manufacturer.)**
- Handheld Laser Power Sources
- Insight Welding Intelligence Products (Except External Sensors)
- Inverter Power Sources
- Plasma Arc Cutting Power Sources
- Process Controllers
- Semi-Automatic and Automatic Wire Feeders
- Transformer/Rectifier Power Sources

#### 4 2 Years — Parts and Labor

- Auto-Darkening Weld Masks (No Labor)
- Fume Extractors - Filtair 215, Capture 5, and Industrial Collector Series

#### 5 1 Year — Parts and Labor Unless Specified

- ArcReach Heater
- AugmentedArc, LiveArc, and MobileArc Welding Systems
- Automatic Motion Devices
- Bernard BTB Air-Cooled MIG Guns (No Labor)
- CoolBelt, PAPR Blower, and PAPR Face Shield (No Labor)
- Desiccant Air Dryer System

- Field Options **(NOTE: Field options are covered for the remaining warranty period of the product they are installed in, or for a minimum of one year — whichever is greater.)**

- RFCS Foot Controls (Except RFCS-RJ45)
- Fume Extractors - Filtair 130, MWX and SWX Series, Standard, Telescopic, and ZoneFlow Extraction Arms and Motor Control Box
- Handheld Laser Torches (No Labor)
- HF Units
- Induction Heating Power Sources, Coolers **(NOTE: Digital Recorders are Warranted Separately by the Manufacturer.)**
- Insight Sensors
- Laser Welding Helmets (No Labor)
- Load Banks
- MDX Series MIG Guns (No Labor)
- Motor-Driven Guns
- Positioners and Controllers
- Racks (For Housing Multiple Power Sources)
- Running Gear/Trailers
- Spoolmate Spoolguns (No Labor)
- Subarc Wire Drive Assemblies
- Supplied Air Respirator (SAR) Boxes and Panels
- TIG Torches (No Labor)
- Tregaskiss Guns (No Labor)
- Water Cooling Systems
- Wireless Remote Foot/Hand Controls and Receivers
- Work Stations/Weld Tables (No Labor)
- XT Plasma Cutting Torches (No Labor)

#### 6 6 Months — Parts

- 12 Volt Automotive-Style Batteries

#### 7 90 Days — Parts

- Accessories (Kits)
- ArcReach Heater Quick Wrap and Air Cooled Cables
- Canvas Covers
- Induction Heating Coils and Blankets, Cables, and Non-Electronic Controls
- M-Guns
- MIG Guns, Subarc (SAW) Torches, and External Cladding Heads
- Remote Controls and RFCS-RJ45
- Replacement Parts (No labor)

Miller's True Blue<sup>®</sup> Limited Warranty shall not apply to:

1. **Consumable components; such as contact tips, cutting nozzles, contactors, brushes, relays, work station table tops and welding curtains, or parts that fail due to normal wear. (Exception: brushes and relays are covered on all engine-driven products.)**
2. Items furnished by Miller, but manufactured by others, such as engines or trade accessories. These items are covered by the manufacturer's warranty, if any.
3. Equipment that has been modified by any party other than Miller, or equipment that has been improperly installed, improperly operated or

misused based upon industry standards, or equipment which has not had reasonable and necessary maintenance, or equipment which has been used for operation outside of the specifications for the equipment.

4. Defects caused by accident, unauthorized repair, or improper testing.

MILLER PRODUCTS ARE INTENDED FOR COMMERCIAL AND INDUSTRIAL USERS TRAINED AND EXPERIENCED IN THE USE AND MAINTENANCE OF WELDING EQUIPMENT.

The exclusive remedies for warranty claims are, at Miller's option, either: (1) repair; or (2) replacement; or, if approved in writing by Miller, (3) the pre-approved cost of repair or replacement at an authorized Miller service station; or (4) payment of or credit for the purchase price (less reasonable depreciation based upon use). Products may not be returned without Miller's written approval. Return shipment shall be at customer's risk and expense.

The above remedies are F.O.B. Appleton, WI, or Miller's authorized service facility. Transportation and freight are the customer's responsibility. TO THE EXTENT PERMITTED BY LAW, THE REMEDIES HEREIN ARE THE SOLE AND EXCLUSIVE REMEDIES REGARDLESS OF THE LEGAL THEORY. IN NO EVENT SHALL MILLER BE LIABLE FOR DIRECT, INDIRECT, SPECIAL, INCIDENTAL OR CONSEQUENTIAL DAMAGES (INCLUDING LOSS OF PROFIT) REGARDLESS OF THE LEGAL THEORY. ANY WARRANTY NOT PROVIDED HEREIN AND ANY IMPLIED WARRANTY, GUARANTY, OR REPRESENTATION, INCLUDING ANY IMPLIED WARRANTY OF MERCHANTABILITY OR FITNESS FOR PARTICULAR PURPOSE, ARE EXCLUDED AND DISCLAIMED BY MILLER.

Some US states do not allow limiting the duration of an implied warranty or the exclusion of certain damages, so the above limitations may not apply to you. This warranty provides specific legal rights, and other rights may be available depending on your state. In Canada, some provinces provide additional warranties or remedies, and to the extent the law prohibits their waiver, the limitations set out above may not apply. This Limited Warranty provides specific legal rights, and other rights may be available, but may vary by province.

### Warranty Questions?

Call 1-800-4-A-MILLER for your local Miller distributor.

Your distributor also gives you...

#### Service

You always get the fast, reliable response you need. Most replacement parts can be in your hands in 24 hours.

#### Support

Need fast answers to the tough welding questions? The expertise of the distributor and Miller is there to help you, every step of the way.

# Owner's Record

Please complete and retain with your personal records.

Model Name \_\_\_\_\_ Serial/Style Number \_\_\_\_\_

Purchase Date \_\_\_\_\_ (Date which equipment was delivered to original customer.) \_\_\_\_\_

Distributor \_\_\_\_\_

Address \_\_\_\_\_

City \_\_\_\_\_

State \_\_\_\_\_ Zip \_\_\_\_\_

## For Service

**Contact a *DISTRIBUTOR* or *SERVICE AGENCY* near you.**

Always provide Model Name and Serial/Style Number.

Contact your Distributor for:

Welding Supplies and Consumables

Options and Accessories

Personal Protective Equipment (PPE)

Service and Repair Replacement Parts

Training (Schools, Videos, Books)

Welding Process Handbooks

To locate a Distributor or Service Agency visit  
[www.millerwelds.com](http://www.millerwelds.com) or call 1-800-4-A-Miller

Contact the Delivering Carrier to:

File a claim for loss or damage during shipment.

For assistance in filing or settling claims, contact your distributor and/or equipment manufacturer's Transportation Department.

### Miller Electric Mfg. LLC

An Illinois Tool Works Company  
1635 West Spencer Street  
Appleton, WI 54914 USA

### International Headquarters—USA

USA Phone: 920-735-4505  
USA & Canada FAX: 920-735-4134  
International FAX: 920-735-4125

For International Locations Visit  
[www.MillerWelds.com](http://www.MillerWelds.com)

