



OM-274231E

2019-12

Processes



Description

Cooler For Water-Cooled MIG Guns

Continuum[®] Cooler CE

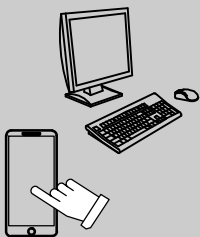
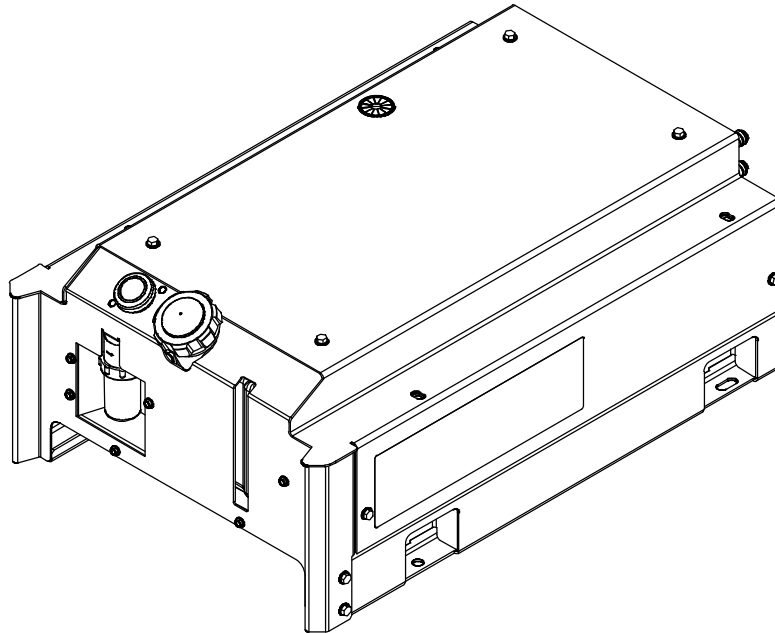

For product information,
Owner's Manual translations,
and more, visit

www.MillerWelds.com

OWNER'S MANUAL

File: Cooler



From Miller to You

Thank you and congratulations on choosing Miller. Now you can get the job done and get it done right. We know you don't have time to do it any other way.

That's why when Niels Miller first started building arc welders in 1929, he made sure his products offered long-lasting value and superior quality. Like you, his customers couldn't afford anything less. Miller products had to be more than the best they could be. They had to be the best you could buy.

Today, the people that build and sell Miller products continue the tradition. They're just as committed to providing equipment and service that meets the high standards of quality and value established in 1929.

This Owner's Manual is designed to help you get the most out of your Miller products. Please take time to read the Safety Precautions. They will help you protect yourself against potential hazards on the worksite.



ISO 9001
Quality

Miller is the first welding equipment manufacturer in the U.S.A. to be registered to the ISO 9001 Quality System Standard.

We've made installation and operation quick and easy. With Miller, you can count on years of reliable service with proper maintenance. And if for some reason the unit needs repair, there's a Troubleshooting section that will help you figure out what the problem is, and our extensive service network is there to help fix the problem. Warranty and maintenance information for your particular model are also provided.



Miller Electric manufactures a full line of welders and welding-related equipment. For information on other quality Miller products, contact your local Miller distributor to receive the latest full line catalog or individual specification sheets. **To locate your nearest distributor or service agency call 1-800-4-A-Miller, or visit us at www.MillerWelds.com on the web.**



Working as hard as you do – every power source from Miller is backed by the most hassle-free warranty in the business.



TABLE OF CONTENTS

SECTION 1 – SAFETY PRECAUTIONS - READ BEFORE USING	1
1-1. Symbol Usage	1
1-2. Cooling Equipment Hazards	1
1-3. Additional Symbols For Installation, Operation, And Maintenance	1
1-4. California Proposition 65 Warnings	2
1-5. Principal Safety Standards	2
SECTION 2 – CONSIGNES DE SÉCURITÉ – LIRE AVANT UTILISATION	3
2-1. Symboles utilisés	3
2-2. Dangers liés aux équipements de refroidissement	3
2-3. Dangers supplémentaires en relation avec l'installation, le fonctionnement et la maintenance	4
2-4. Proposition californienne 65 Avertissements	4
2-5. Principales normes de sécurité	4
SECTION 3 – DEFINITIONS	5
3-1. Additional Safety Symbols And Definitions	5
3-2. Miscellaneous Symbols And Definitions	6
SECTION 4 – SPECIFICATIONS	7
4-1. Serial Number And Rating Label Location	7
4-2. Specifications	7
4-3. Coolant Specifications	7
4-4. Environmental Specifications	7
SECTION 5 – INSTALLATION	8
5-1. Selecting A Location	8
5-2. Measuring And Discharging Input Capacitor Voltage	9
5-3. Installing Cooler	10
5-4. Installing Harness from Cooler to Power Source	11
SECTION 6 – OPERATION	12
6-1. Cooler Controls	12
SECTION 7 – MAINTENANCE	13
7-1. Routine Maintenance	13
7-2. Coolant Maintenance	13
7-3. Flow Direction	14
7-4. Error Code Troubleshooting Description And Tables	14
7-5. Troubleshooting	14
SECTION 8 – ELECTRICAL DIAGRAM	15
SECTION 9 – PARTS LIST	16
WARRANTY	



DECLARATION OF CONFORMITY

for European Community (CE marked) products.

MILLER Electric Mfg. Co., 1635 Spencer Street, Appleton, WI 54914 U.S.A. declares that the product(s) identified in this declaration conform to the essential requirements and provisions of the stated Council Directive(s) and Standard(s).

Product/Apparatus Identification:

Product	Stock Number
Continuum Cooler	301214

Council Directives:

- 2014/35/EU Low voltage
- 2014/30/EU Electromagnetic compatibility
- 2011/65/EU Restriction of the use of certain hazardous substances in electrical and electronic equipment

Standards:

- IEC 60974-2:2013 Arc welding equipment – Part 2: Liquid cooling systems
- IEC 60974-10:2014 Arc welding equipment – Part 10: Electromagnetic compatibility requirements

Signatory:

January 25, 2017

David A. Werba

MANAGER, PRODUCT DESIGN COMPLIANCE

Date of Declaration

SECTION 1 – SAFETY PRECAUTIONS - READ BEFORE USING

coolers 2018-01

 Protect yourself and others from injury — read, follow, and save these important safety precautions and operating instructions.

1-1. Symbol Usage

 **DANGER!** – Indicates a hazardous situation which, if not avoided, will result in death or serious injury. The possible hazards are shown in the adjoining symbols or explained in the text.

 Indicates a hazardous situation which, if not avoided, could result in death or serious injury. The possible hazards are shown in the adjoining symbols or explained in the text.

NOTICE – Indicates statements not related to personal injury.

 Indicates special instructions.



This group of symbols means Warning! Watch Out! ELECTRIC SHOCK, MOVING PARTS, and HOT PARTS hazards. Consult symbols and related instructions below for necessary actions to avoid the hazards.

1-2. Cooling Equipment Hazards

 The symbols shown below are used throughout this manual to call attention to and identify possible hazards. When you see the symbol, watch out, and follow the related instructions to avoid the hazard. The safety information given below is only a summary of the more complete safety information found in the Safety Standards listed in Section 1-5. Read and follow all Safety Standards.

 Only qualified persons should install, operate, maintain, and repair this equipment. A qualified person is defined as one who, by possession of a recognized degree, certificate, or professional standing, or who by extensive knowledge, training and experience, has successfully demonstrated ability to solve or resolve problems relating to the subject matter, the work, or the project and has received safety training to recognize and avoid the hazards involved.

 During operation, keep everybody, especially children, away.



HOT PARTS can burn.

- Do not touch hot parts bare handed.
- Allow cooling period before working on equipment.
- To handle hot parts, use proper tools and/or wear heavy, insulated welding gloves and clothing to prevent burns.

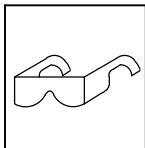

FLYING METAL or DIRT can injure eyes.

- Wear approved safety glasses with side shields even under your welding helmet.



ELECTRIC SHOCK can kill.

Touching live electrical parts can cause fatal shocks or severe burns. The input power circuit and machine internal circuits are also live when power is on. Incorrectly installed or improperly grounded equipment is a hazard.

- Do not touch live electrical parts.
- Disconnect input power or stop engine before installing or servicing this equipment. Lockout/tagout input power according to OSHA 29 CFR 1910.147 (see Safety Standards).
- Properly install, ground, and operate this equipment according to its Owner's Manual and national, state, and local codes.
- Always verify the supply ground – check and be sure that input power cord ground wire is properly connected to ground terminal in disconnect box or that cord plug is connected to a properly grounded receptacle outlet.
- Keep cords dry, free of oil and grease, and protected from hot metal and sparks.
- Frequently inspect input power cord and ground conductor for damage or bare wiring – replace immediately if damaged – bare wiring can kill.
- Turn off all equipment when not in use.
- Use only well-maintained equipment. Repair or replace damaged parts at once. Maintain unit according to manual.
- Keep all panels and covers securely in place.

1-3. Additional Symbols For Installation, Operation, And Maintenance



FALLING EQUIPMENT can injure.

- Use correct procedures and equipment of adequate capacity to lift and support unit.
- If using lift forks to move unit, be sure forks are long enough to extend beyond opposite side of unit.
- Keep equipment (cables and cords) away from moving vehicles when working from an aerial location.
- Follow the guidelines in the Applications Manual for the Revised NIOSH Lifting Equation (Publication No. 94-110) when manually lifting heavy parts or equipment.

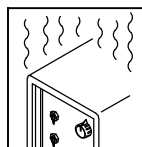

OVERUSE can cause OVERHEATING

- Allow cooling period; follow rated duty cycle.
- Do not block or filter airflow to unit.

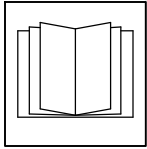

READ INSTRUCTIONS.

- Read and follow all labels and the Owner's Manual carefully before installing, operating, or servicing unit. Read the safety information at the beginning of the manual and in each section.
- Use only genuine replacement parts from the manufacturer.
- Perform installation, maintenance, and service according to the Owner's Manuals, industry standards, and national, state, and local codes.
- Read and understand the Safety Data Sheets (SDSs) and the manufacturer's instructions for adhesives, coatings, cleaners, consumables, coolants, degreasers, fluxes, and metals.



STEAM AND HOT COOLANT can burn.

Hose may rupture if coolant overheats.

- Visually inspect condition of hoses before each use. Do not use damaged hoses.
- Allow cooling period before working on equipment.



HIGH PRESSURE FLUIDS can injure or kill.

- Coolant can be under high pressure.
- Release pressure before working on cooler.
- If ANY fluid is injected into the skin or body seek medical help immediately.



MOVING PARTS can injure.

- Keep away from moving parts such as fans.
- Keep all doors, panels, covers, and guards closed and securely in place.
- Have only qualified persons remove doors, panels, covers, or guards for maintenance and troubleshooting as necessary.
- Reinstall doors, panels, covers, or guards when maintenance is finished and before reconnecting input power.

1-4. California Proposition 65 Warnings

⚠ WARNING: This product can expose you to chemicals including lead, which are known to the state of California to cause cancer and birth defects or other reproductive harm.

For more information, go to www.P65Warnings.ca.gov.

1-5. Principal Safety Standards

Safety in Welding, Cutting, and Allied Processes, ANSI Standard Z49.1, is available as a free download from the American Welding Society at <http://www.aws.org> or purchased from Global Engineering Documents (phone: 1-877-413-5184, website: www.global.ihs.com).

Safe Practices for the Preparation of Containers and Piping for Welding and Cutting, American Welding Society Standard AWS F4.1, from Global Engineering Documents (phone: 1-877-413-5184, website: www.global.ihs.com).

Safe Practices for Welding and Cutting Containers that have Held Combustibles, American Welding Society Standard AWS A6.0, from Global Engineering Documents (phone: 1-877-413-5184, website: www.global.ihs.com).

National Electrical Code, NFPA Standard 70, from National Fire Protection Association, Quincy, MA 02169 (phone: 1-800-344-3555, website: www.nfpa.org and www.sparky.org).

Safe Handling of Compressed Gases in Cylinders, CGA Pamphlet P-1, from Compressed Gas Association, 14501 George Carter Way, Suite 103, Chantilly, VA 20151 (phone: 703-788-2700, website: www.cganet.com).

Safety in Welding, Cutting, and Allied Processes, CSA Standard W117.2, from Canadian Standards Association, Standards Sales, 5060 Spectrum Way, Suite 100, Mississauga, Ontario, Canada L4W 5N5 (phone: 800-463-6727, website: www.csagroup.org).

Safe Practice For Occupational And Educational Eye And Face Protection, ANSI Standard Z87.1, from American National Standards Institute, 25 West 43rd Street, New York, NY 10036 (phone: 212-642-4900, website: www.ansi.org).

Standard for Fire Prevention During Welding, Cutting, and Other Hot Work, NFPA Standard 51B, from National Fire Protection Association, Quincy, MA 02269 (phone: 1-800-344-3555, website: www.nfpa.org). OSHA, Occupational Safety and Health Standards for General Industry, Title 29, Code of Federal Regulations (CFR), Part 1910.177 Subpart N, Part 1910 Subpart Q, and Part 1926, Subpart J, from U.S. Government Printing Office, Superintendent of Documents, P.O. Box 371954, Pittsburgh, PA 15250-7954 (phone: 1-866-512-1800) (there are 10 OSHA Regional Offices—phone for Region 5, Chicago, is 312-353-2220, website: www.osha.gov).

Applications Manual for the Revised NIOSH Lifting Equation, The National Institute for Occupational Safety and Health (NIOSH), 1600 Clifton Rd, Atlanta, GA 30329-4027 (phone: 1-800-232-4636, website: www.cdc.gov/NIOSH).

SECTION 2 – CONSIGNES DE SÉCURITÉ – LIRE AVANT UTILISATION

cooler_2018-01_fre

! Pour écarter les risques de blessure pour vous-même et pour autrui — lire, appliquer et ranger en lieu sûr ces consignes relatives aux précautions de sécurité et au mode opératoire.

2-1. Symboles utilisés



DANGER! – Indique une situation dangereuse qui si on l'évite pas peut donner la mort ou des blessures graves. Les dangers possibles sont montrés par les symboles joints ou sont expliqués dans le texte.



Indique une situation dangereuse qui si on l'évite pas peut donner la mort ou des blessures graves. Les dangers possibles sont montrés par les symboles joints ou sont expliqués dans le texte.

AVIS – Indique des déclarations pas en relation avec des blessures personnelles.

 Indique des instructions spécifiques.



Ce groupe de symboles veut dire Avertissement! Attention! DANGER DE CHOC ÉLECTRIQUE, PIÈCES EN MOUVEMENT, et PIÈCES CHAUDES. Consulter les symboles et les instructions ci-dessous y afférant pour les actions nécessaires afin d'éviter le danger.

2-2. Dangers liés aux équipements de refroidissement



Les symboles représentés ci-dessous sont utilisés dans ce manuel pour attirer l'attention et identifier les dangers possibles. En présence de l'un de ces symboles, prendre garde et suivre les instructions afférentes pour éviter tout risque. Les instructions en matière de sécurité indiquées ci-dessous ne constituent qu'un sommaire des instructions de sécurité plus complètes fournies dans les normes de sécurité énumérées dans la Section 2-5. Lire et observer toutes les normes de sécurité.



L'installation, l'utilisation, l'entretien et les réparations ne doivent être confiés qu'à des personnes qualifiées. Une personne qualifiée est définie comme celle qui, par la possession d'un diplôme reconnu, d'un certificat ou d'un statut professionnel, ou qui, par une connaissance, une formation et une expérience approfondies, a démontré avec succès sa capacité à résoudre les problèmes liés à la tâche, le travail ou le projet et a reçu une formation en sécurité afin de reconnaître et d'éviter les risques inhérents.



Pendant le fonctionnement, maintenir à distance toutes les personnes, notamment les enfants de l'appareil.



LES PIÈCES CHAUDES peuvent provoquer des brûlures.

- Ne pas toucher à mains nues les parties chaudes.
- Prévoir une période de refroidissement avant de travailler à l'équipement.
- Ne pas toucher aux pièces chaudes, utiliser les outils recommandés et porter des gants de soudage et des vêtements épais pour éviter les brûlures.

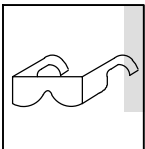

DES PIÈCES DE METAL ou **DES SALETES** peuvent provoquer des blessures dans les yeux.

- Porter des lunettes de sécurité avec écrans latéraux ou un écran facial.



UNE DÉCHARGE ÉLECTRIQUE peut entraîner la mort.

Le contact d'organes électriques sous tension peut provoquer des accidents mortels ou des brûlures graves. Le circuit d'alimentation et les circuits internes de la machine sont également sous tension lorsque l'alimentation est sur Marche. Un équipement installé ou mis à la terre de manière incorrecte ou impropre constitue un danger.

- Ne pas toucher aux pièces électriques sous tension.
- Couper l'alimentation ou arrêter le moteur avant de procéder à l'installation, à la réparation ou à l'entretien de l'appareil. Déverrouiller l'alimentation selon la norme OSHA 29 CFR 1910.147 (voir normes de sécurité).
- Installez, mettez à la terre et utilisez correctement cet équipement conformément à son Manuel d'Utilisation et aux réglementations nationales, gouvernementales et locales.
- Toujours vérifier la terre du cordon d'alimentation. Vérifier et s'assurer que le fil de terre du cordon d'alimentation est bien raccordé à la borne de terre du sectionneur ou que la fiche du cordon est raccordée à une prise correctement mise à la terre.
- Les câbles doivent être exempts d'humidité, d'huile et de graisse; protégez-les contre les étincelles et les pièces métalliques chaudes.
- Vérifier fréquemment le cordon d'alimentation afin de s'assurer qu'il n'est pas altéré ou à nu, le remplacer immédiatement s'il l'est. Un fil à nu peut entraîner la mort.
- L'équipement doit être hors tension lorsqu'il n'est pas utilisé.
- N'utiliser qu'un matériel en bon état. Réparer ou remplacer sur-le-champ les pièces endommagées. Entretien l'appareil conformément à ce manuel.
- S'assurer que tous les panneaux et couvercles sont correctement en place.

2-3. Dangers supplémentaires en relation avec l'installation, le fonctionnement et la maintenance



LA CHUTE DE L'ÉQUIPEMENT peut provoquer des blessures.

- Utilisez les procédures correctes et des équipements d'une capacité appropriée pour soulever et supporter l'appareil.
- En utilisant des fourches de levage pour déplacer l'unité, s'assurer que les fourches sont suffisamment longues pour dépasser du côté opposé de l'appareil.
- Tenir l'équipement (câbles et cordons) à distance des véhicules mobiles lors de toute opération en hauteur.
- Suivre les consignes du Manuel des applications pour l'équation de levage NIOSH révisée (Publication N°94-110) lors du levage manuel de pièces ou équipements lourds.

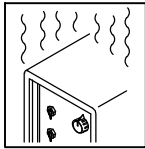

L'EMPLOI EXCESSIF peut SURCHAUFFER L'ÉQUIPEMENT.

- Prévoir une période de refroidissement ; respecter le cycle opératoire nominal.
- Ne pas obstruer les passages d'air du poste.

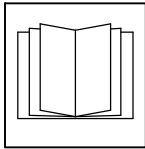

LIRE LES INSTRUCTIONS.

- Lire et appliquer les instructions sur les étiquettes et le Mode d'emploi avant l'installation, l'utilisation ou l'entretien de l'appareil. Lire les informations de sécurité au début du manuel et dans chaque section.
- N'utiliser que les pièces de rechange recommandées par le constructeur.
- Effectuer l'installation, l'entretien et toute intervention selon les manuels d'utilisateurs, les normes nationales, provinciales et de l'industrie, ainsi que les codes municipaux.
- Lire et comprendre les fiches de données de sécurité et les instructions du fabricant concernant les adhésifs, les revêtements, les nettoyeurs, les consommables, les produits de refroidissement, les dégraissants, les flux et les métaux.

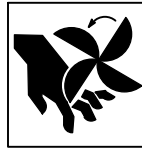

Les PIÈCES MOBILES peuvent causer des blessures.

- S'abstenir de toucher des organes mobiles tels que des ventilateurs.
- Maintenir fermés et verrouillés les portes, panneaux, recouvrements et dispositifs de protection.
- Lorsque cela est nécessaire pour des travaux d'entretien et de dépannage, faire retirer les portes, panneaux, recouvrements ou dispositifs de protection uniquement par du personnel qualifié.
- Remettre les portes, panneaux, recouvrements ou dispositifs de protection quand l'entretien est terminé et avant de rebrancher l'alimentation électrique.



LA VAPEUR ET LE LIQUIDE DE REFROIDISSEMENT CHAUD peuvent provoquer des brûlures.

Un tuyau peut se rompre lorsque le liquide de refroidissement surchauffe.

- Vérifiez visuellement l'état des tuyaux avant chaque utilisation. N'utilisez pas de tuyaux endommagés.
- Laissez refroidir avant d'intervenir sur l'équipement.



LES LIQUIDES SOUS HAUTE PRESSION peuvent provoquer des blessures ou la mort.

- Liquide de refroidissement sous haute pression.
- Libérez la pression avant d'intervenir sur le refroidisseur.
- En cas d'injection d'un liquide QUELCONQUE dans la peau ou le corps, consultez immédiatement un médecin.

2-4. Proposition californienne 65 Avertissements

⚠ AVERTISSEMENT : ce produit peut vous exposer à des produits chimiques tels que le plomb, reconnu par l'État de Californie comme cancérigène et sources de malformations ou d'autres troubles de la reproduction.

Pour plus d'informations, consulter www.P65Warnings.ca.gov.

2-5. Principales normes de sécurité

Safety in Welding, Cutting, and Allied Processes, ANSI Standard Z49.1, is available as a free download from the American Welding Society at <http://www.aws.org> or purchased from Global Engineering Documents (phone: 1-877-413-5184, website: www.global.ihs.com).

Safe Practices for the Preparation of Containers and Piping for Welding and Cutting, American Welding Society Standard AWS F4.1, from Global Engineering Documents (phone: 1-877-413-5184, website: www.global.ihs.com).

Safe Practices for Welding and Cutting Containers that have Held Combustibles, American Welding Society Standard AWS A6.0, from Global Engineering Documents (phone: 1-877-413-5184, website: www.global.ihs.com).

National Electrical Code, NFPA Standard 70, from National Fire Protection Association, Quincy, MA 02169 (phone: 1-800-344-3555, website: www.nfpa.org and www.sparky.org).

Safe Handling of Compressed Gases in Cylinders, CGA Pamphlet P-1, from Compressed Gas Association, 14501 George Carter Way, Suite 103, Chantilly, VA 20151 (phone: 703-788-2700, website: www.cganet.com).

Safety in Welding, Cutting, and Allied Processes, CSA Standard W117.2, from Canadian Standards Association, Standards Sales, 5060 Spectrum Way, Suite 100, Mississauga, Ontario, Canada L4W 5N5 (phone: 800-463-6727, website: www.csagroup.org).

Safe Practice For Occupational And Educational Eye And Face Protection, ANSI Standard Z87.1, from American National Standards Institute, 25 West 43rd Street, New York, NY 10036 (phone: 212-642-4900, website: www.ansi.org).



Standard for Fire Prevention During Welding, Cutting, and Other Hot Work, NFPA Standard 51B, from National Fire Protection Association, Quincy, MA 02269 (phone: 1-800-344-3555, website: www.nfpa.org). OSHA, Occupational Safety and Health Standards for General Industry, Title 29, Code of Federal Regulations (CFR), Part 1910, Subpart Q, and Part 1926, Subpart J, auprès du U.S. Government Printing Office, Superintendent of Documents, P.O. Box 371954, Pittsburgh, PA 15250-7954 (téléphone : 1-866-512-1800) (il y a 10 bureaux régionaux—le téléphone de la région 5, Chicago, est 3123532220, site Internet : www.osha.gov).

Applications Manual for the Revised NIOSH Lifting Equation, The National Institute for Occupational Safety and Health (NIOSH), 1600 Clifton Rd, Atlanta, GA 30329-4027 (phone: 1-800-232-4636, website: www.cdc.gov/NIOSH).

SECTION 3 – DEFINITIONS



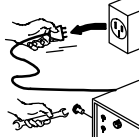
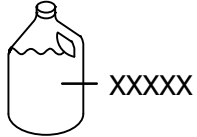
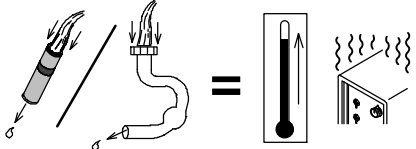
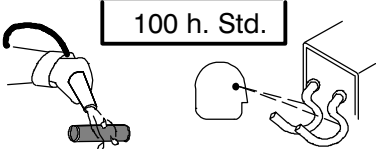

3-1. Additional Safety Symbols And Definitions

 Some symbols are found only on CE products.







	<p>Warning! Watch Out! There are possible hazards as shown by the symbols.</p> <p style="text-align: right;">Safe1 2012-05</p>
	<p>Do not discard product (where applicable) with general waste. Reuse or recycle Waste Electrical and Electronic Equipment (WEEE) by disposing at a designated collection facility. Contact your local recycling office or your local distributor for further information.</p> <p style="text-align: right;">Safe37 2012-05</p>
	<p>Disconnect input plug or power before working on machine.</p> <p style="text-align: right;">Safe30 2012-05</p>
	<p>Use coolant suggested by the manufacturer.</p> <p style="text-align: right;">Safe52 2012-05</p>
	<p>Plugged filter or hoses can cause overheating to the power source and torch.</p> <p style="text-align: right;">Safe50 2012-05</p>
	<p>Every 100 hours, check and clean filter and check condition of hoses.</p> <p style="text-align: right;">Safe51 2012-05</p>

3-2. Miscellaneous Symbols And Definitions

 Some symbols are found only on CE products.

A	Amperage
V	Volts
	Cooling
	Water (Coolant) Input
	Water (Coolant) Output
	Line Connection
	Protective Earth (Ground)
IP	Degree Of Protection

U₁	Primary Voltage
I₁	Primary Current
I	On
O	Off
P₁	Rated Cooling Power
p_{max}	Rated Maximum Pressure
	Gas Metal Arc Welding MIG/MAG (GMAW)

	Circuit Breaker
1 	Single Phase
	Gas Tungsten Arc Welding (GTAW) / Tungsten Inert Gas (TIG) Welding
Hz	Hertz
	Alternating Current
	Voltage Input
	Circulating Unit With Coolant Pump

SECTION 4 – SPECIFICATIONS

4-1. Serial Number And Rating Label Location

The serial number and rating information for this product is located on the front . Use rating label to determine input power requirements and/or rated output. For future reference, write serial number in space provided on back cover of this manual.

4-2. Software Licensing Agreement

The End User License Agreement and any third-party notices and terms and conditions pertaining to third-party software can be found at <https://www.millerwelds.com/eula> and are incorporated by reference herein.

4-3. Specifications

Input Power	Overall Dimensions	Coolant Capacity	Weight	
			Net	Wet Weight
Control Supply Voltage: 36 VDC Control Signal Voltage: 5 VDC	Length: 27.25 in. (693 mm) Width: 17.25 in. (438 mm) Height: 10.3125 in. (261 mm)	2 gal (7.6 L)	56 lb (25.4 kg)	73 lb (33 kg)

NOTICE – Cooler only operates with output present from Continuum power source.

4-4. Coolant Specifications

 Do not use conductive coolant.

Application	Coolant
GTAW Or Where High Frequency Current Is Used	Low Conductivity Coolant 043810* Distilled Or Deionized Water Okay Above 32°F (0°C)
GMAW Or Where High Frequency Current Is Not Used	Low Conductivity Coolant 043810* Aluminum Protecting Coolant 043809* Distilled Or Deionized Water Okay Above 32°F (0°C)
Where Coolant Contacts Aluminum Parts	Aluminum Protecting Coolant 043809*

*Coolants 043810 and 043809 protect to -37°F (-38°C) and resist algae growth.

NOTICE – Use of any coolant other than those listed in the table voids the warranty on any parts that come in contact with the coolant (pump, radiator, etc.).

4-5. Environmental Specifications

A. IP Rating

IP Rating
IP23S This equipment is designed for outdoor use. It may be stored, but is not intended to be used outside during precipitation unless sheltered.

IP23S 2014-06

B. Information On Electromagnetic Compatibility (EMC)

 This Class A equipment is not intended for use in residential locations where the electrical power is provided by the public low-voltage supply system. There can be potential difficulties in ensuring electromagnetic compatibility in those locations, due to conducted as well as radiated disturbances.

ce-emc 3 2014-07

C. Temperature Specifications

Operating Temperature Range*	Storage/Transportation Temperature Range
14 to 104°F (-10 to 40°C)	-4 to 131°F (-20 to 55°C)

Temp_2016-07

 *The correction factor on the cooling power at an ambient temperature of 104 F (40 °C) is 0.625.

D. China EEP Hazardous Substance Information

中国电器电子产品中有害物质的名称及含量 China EEP Hazardous Substance Information						
部件名称 Component Name (如果适用) (if applicable)	有害物质 Hazardous Substance					
	铅 Pb	汞 Hg	镉 Cd	六价铬 Cr6	多溴联苯 PBB	多溴二苯醚 PBDE
黄铜和铜部件 Brass and Copper Parts	X	O	O	O	O	O
耦合装置 Coupling Devices	X	O	O	O	O	O
开关装置 Switching Devices	O	O	X	O	O	O
线缆和线缆配件 Cable and Cable Accessories	X	O	O	O	O	O
电池 Batteries	X	O	O	O	O	O
本表格依据中国SJ/T 11364的规定编制。 This table is prepared in accordance with China SJ/T 11364.						
O: 表示该有害物质在该部件所有均质材料中的含量均在中国GB/T26572规定的限量要求以下。 Indicates that the concentration of the Hazardous Substance in all homogeneous materials of the part is below the relevant threshold of China GB/T 26572.						
X: 表示该有害物质至少在该部件的某一均质材料中的含量超出中国GB/T26572规定的限量要求。 Indicates that the concentration of the Hazardous Substance in at least one homogeneous material of the part is above the relevant threshold of China GB/T 26572.						
电器电子产品的环保使用期限依据中国SJ/Z11388的规定确定。 The EFUP value of this EEP is defined in accordance with China SJ/Z 11388.					EEP_2016-06	



SECTION 5 – INSTALLATION

5-1. Selecting A Location

⚠ Do not move or operate unit where it could tip.

Loc_cooler 2016-08

5-2. Measuring And Discharging Input Capacitor Voltage

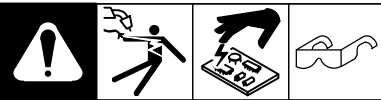

Tools Needed:

3/8 in

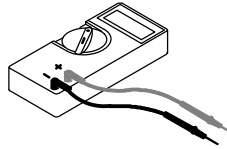

⚠ Turn Off welding power source, and disconnect input power.

⚠ Significant DC voltage can remain on capacitors after unit is Off. Always check the voltage as shown to be sure the input capacitors have discharged before working on unit.

Remove side panels and top cover.

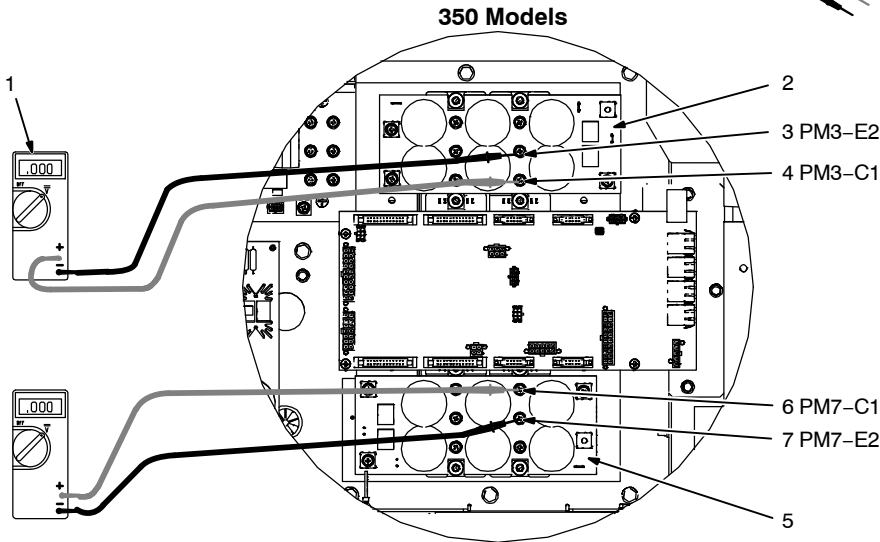

Measure the DC voltage across screw terminals of IGBT modules as shown. Wait until voltage drops to near 0 (zero) volts before proceeding.

ⓘ If the capacitor voltage does not drop to near zero after several minutes, use a bleeder resistor of between 25 and 1000 Ohms, at least 5 watts, #16 AWG 1000 volts DC insulating rating wire to discharge the capacitor(s).

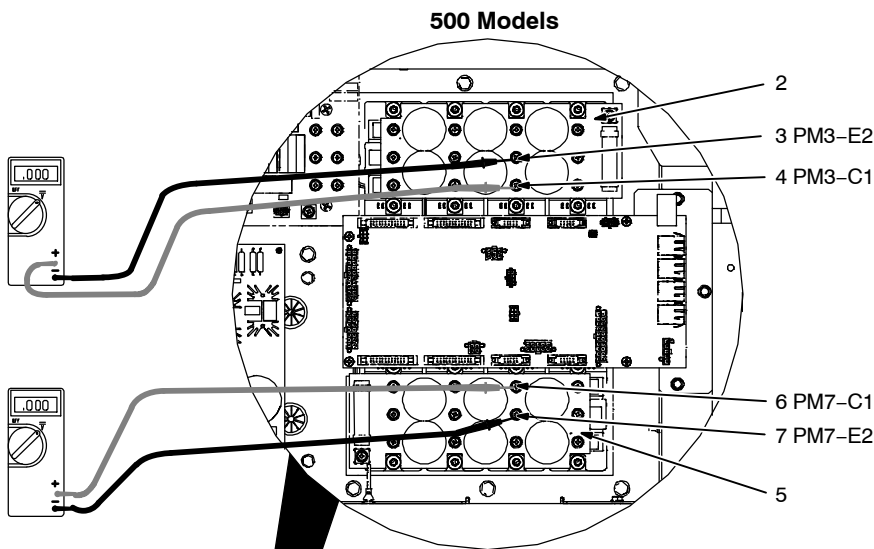

8 Typical Bleeder Resistor

An example of a typical bleeder resistor is shown on this page.

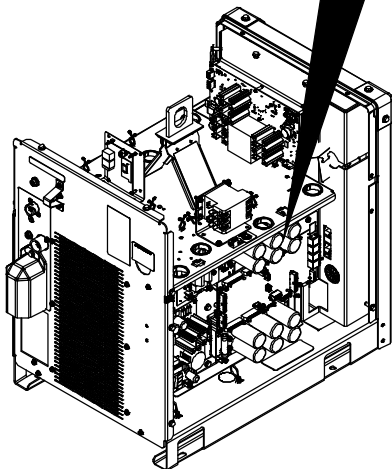

500 Amp Model Shown

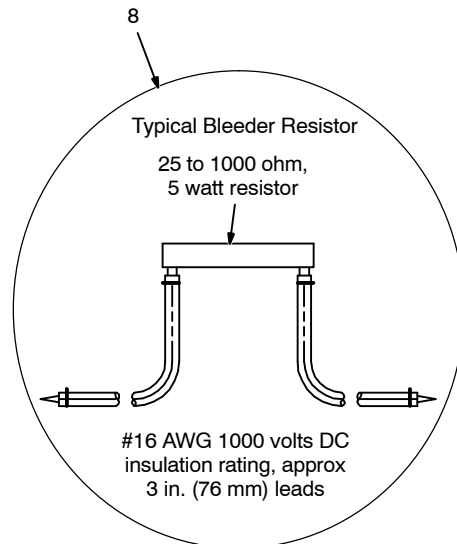

907640TM-TP2/907636TP2

5-3. Installing Cooler



Tools Needed:

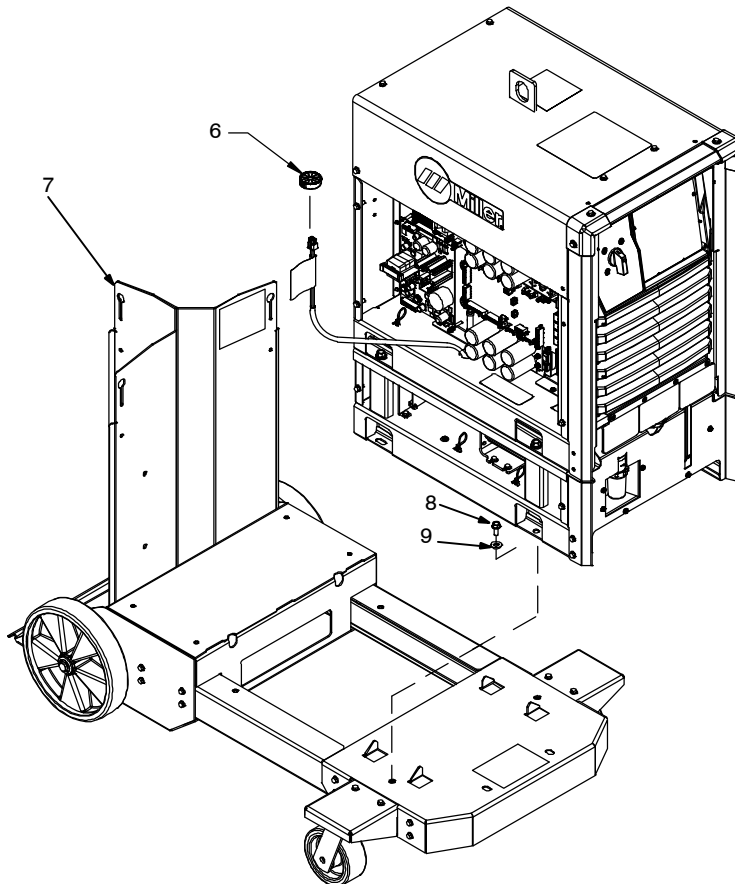
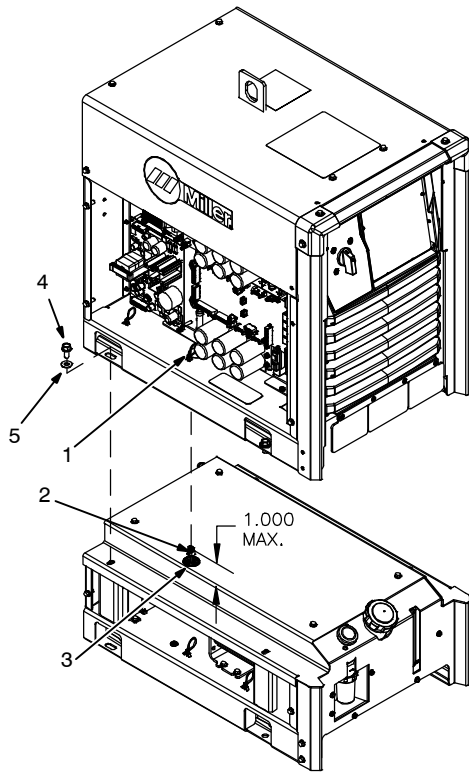
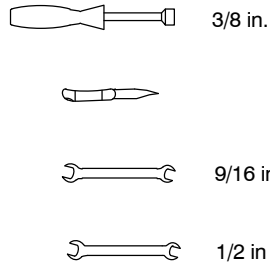

⚠ Turn Off welding power source and disconnect input power.

⚠ Significant DC voltage can remain on capacitors after unit is Off. Always check the voltage as shown in Section 5-2 to be sure the input capacitors have discharged before working on unit.

Remove left side panels from cooler and power source.

1 Power Source Base Knockout Hole

Locate and remove 1.375 in. (35 mm) knockout in power source base.

2 Cooler 6-Pin Plug PLG59

3 Cooler Bushing

Locate plug PLG59 in cooler. Cut cable tie holding PLG59.

Route PLG59 through bushing to a height of no greater than 1 in. (25 mm) above the cooler wrapper.

4 3/8-16 Screw (4)

5 3/8 Washer (4)

Locate bag containing 3/8 hardware and bushing in cooler. Remove the bag from the cooler.

Mount the power source to the cooler using the four supplied 3/8-16 screws and washers. Make sure PLG59 and leads are out of the way of the power source.

6 Power Source Bushing

Pull PLG59 and leads through knockout hole in power source base.

Install supplied bushing over PLG59 and leads into knockout hole.

7 Running Gear (Optional)

8 5/16-18 Screws (4)

9 5/16 Washer (4)

Mount the power source and cooler on running gear (if applicable) using the four supplied 5/16-18 screws and washers. Torque to 120 in. lb (13.5 N·m).

5-4. Installing Harness from Cooler to Power Source



Tools Needed:

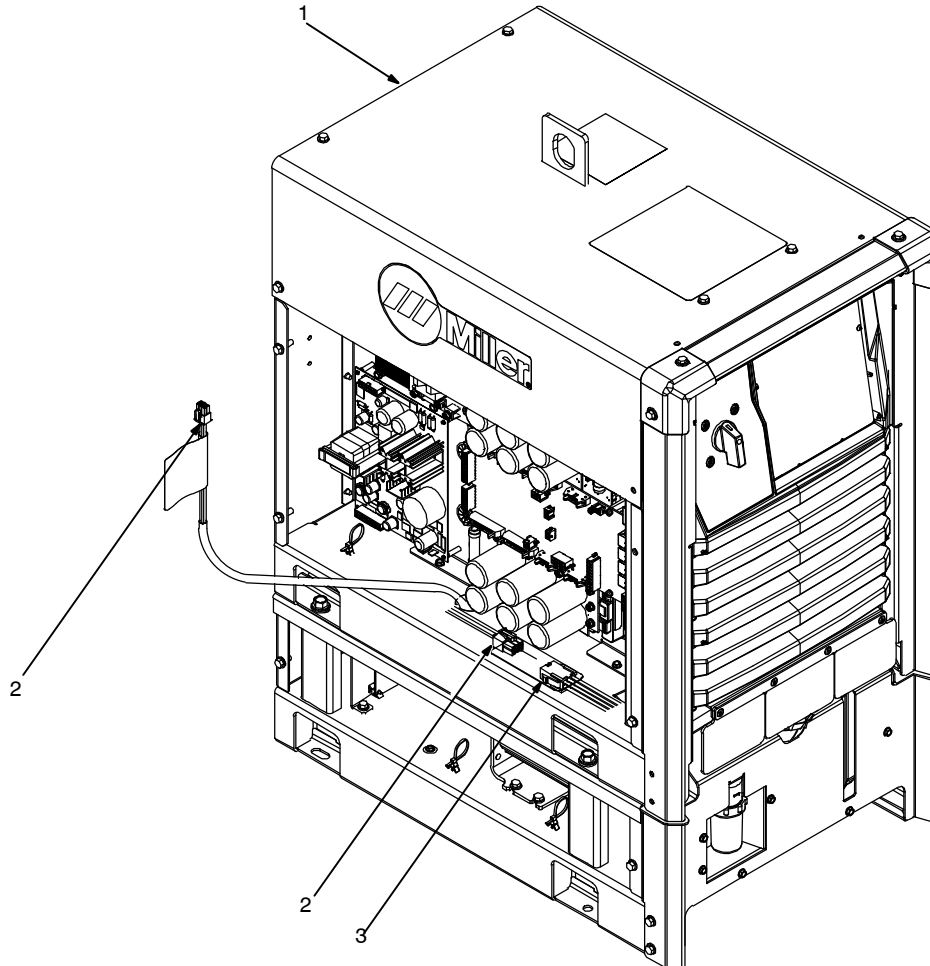
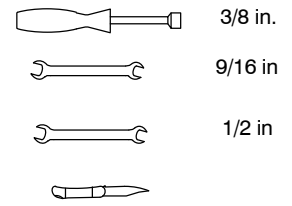

277246-D

- 1 Power Source
 - 2 Cooler 6 Pin Plug PLG 59
 - 3 Power Source 6 Pin Receptacle RC59
- Connect PLG 59 to RC 59 inside power

source. RC 59 is located in the lower right hand corner of the power source
Reinstall left side panels on cooler and power source.

⚠ Make sure Plug 59 is connected to

RC 59 inside power source and not RC6 located on Arc Control board. RC59 will have lead numbers 141, 142, 143, 144, 145 and 146 inserted into connector.

SECTION 6 – OPERATION

6-1. Cooler Controls



- 1 Flow Indicator
- 2 Coolant Filter
- 3 Tank Filler Neck
- 4 Quick Connect; Water Out MIG Gun
- 5 Quick Connect; Water In MIG Gun

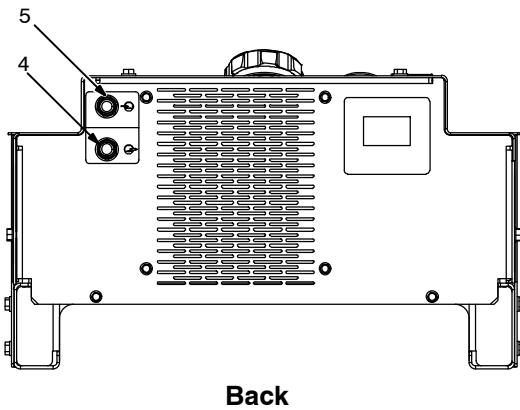

Back

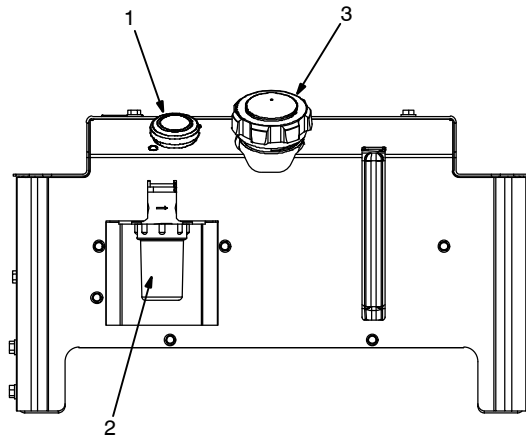

Front







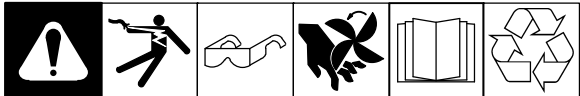

277245-B

NOTICE – Cooler only operates with output present from Continuum power source.

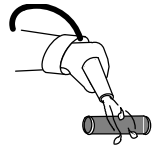
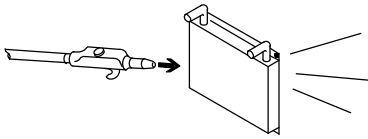

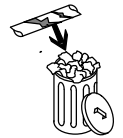
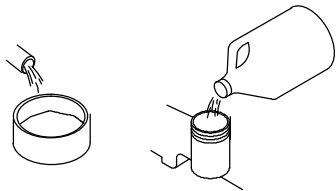
Notes

SECTION 7 – MAINTENANCE

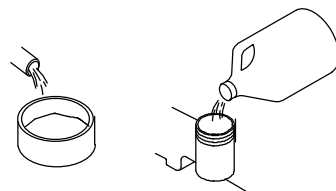
7-1. Routine Maintenance

  Disconnect power before maintaining.					
 3 Months					
 <p>NOTICE – Clean coolant strainer. Severe conditions may require more frequent cleaning (continuous use, high/low temperatures, dirty environment, etc.). Failure to properly clean coolant strainer voids pump warranty.</p>			 <p>Blow Out Heat Exchanger Fins</p>		
 6 Months					
 <p>Replace Cracked Hoses</p>		 <p>Change Coolant (If Using Water)</p>		  <p>Replace Unreadable Labels</p>	
 12 Months					
		 <p>Change Coolant (If Using 043810 Coolant)</p>			

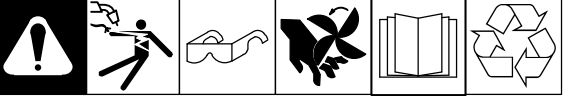
7-2. Coolant Maintenance

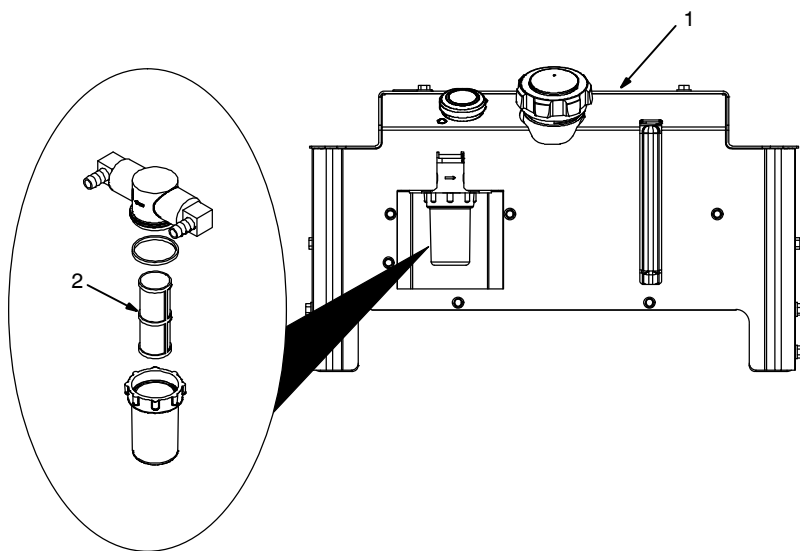
						 <p>Disconnect cooler plug from welding power source receptacle before maintaining.</p>	
						 <p>Dispose of used coolant according to national, state, and local codes. Do not pour down drain.</p>	
						<ol style="list-style-type: none"> 1 Cooler Front Panel 2 Coolant Filter 	
						<p>Unscrew housing to clean filter and housing.</p> <p>Changing Coolant</p> <p>Drain coolant by tipping unit forward. Fill with clean water and run for 10 minutes. Drain and refill.</p> <p>NOTICE – If replacing hoses, use hoses compatible with ethylene glycol, such as Buna-n, Neoprene, or Hypalon. Oxy-acetylene hoses are not compatible with any product containing ethylene glycol.</p>	
						<small>277245-B / coolmaint_2016-08</small>	

7-3. Flow Direction

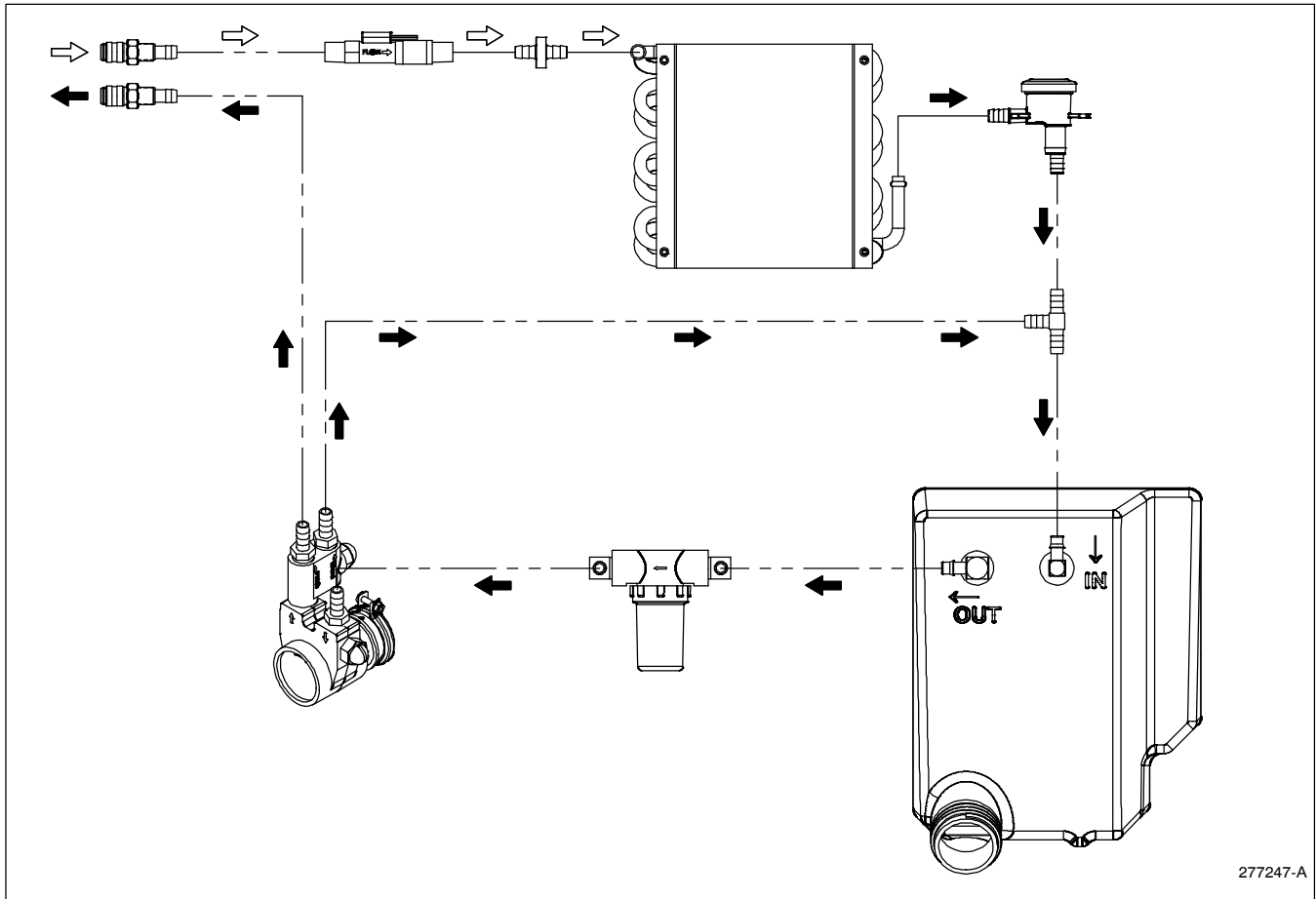

7-4. Error Code Troubleshooting Description And Tables

LED Display Message	Message Type	LCD Display Message	LCD Solution Message	LCD Error Log Message
ERR COMMS	ERROR	Internal comm loss: AC lost Cooler	Press button to clear error	ACM lost comms from Cooler
ERR COOLER	ERROR	Cooler peripheral malfunction	Cycle power on the power source	Cooler USART1 Error
ERR COMMS	ERROR	Internal comm loss: Cooler lost AC	Press button to clear error	Cooler lost comms from ACM
ERR COOLSTAL	ERROR	Cooler Motor Stalled	Press button to clear error	Cooler Motor Stalled
ERR COOLOPEN	ERROR	Cooler Thermistor Open	Press button to clear error	Cooler Thermistor Open
ERR COOLSHRT	ERROR	Cooler Thermistor Shorted	Press button to clear error	Cooler Thermistor Shorted
ERR COOLTEMP	ERROR	Cooler Over Temperature	Press button to clear error	Cooler Over Temperature
ERR COOLFLOW	ERROR	Cooler Low Flow	Press button to clear error	Cooler Low Flow

7-5. Troubleshooting

Trouble		Remedy		
Coolant system does not work.		Be sure cooler input power and communication cables from power source are connected to cooler receptacles.		
		Check input power line fuses or circuit breaker, and replace or reset if necessary.		
		Have Factory Authorized Service Agent check motor.		
Decreased or no coolant flow.		Add coolant.		
		Check for clogged hoses or coolant filter. Clean filter or clean / replace hoses if necessary.		
		Disconnect pump, and check for sheared coupling. Replace coupling if necessary.		

SECTION 8 – ELECTRICAL DIAGRAM

	<p>WARNING</p> <ul style="list-style-type: none"> • Do not touch live electrical parts. • Disconnect input power or stop engine before servicing. • Do not operate with covers removed. • Have only qualified persons install, use, or service this unit.
<p>ELECTRIC SHOCK HAZARD</p>	

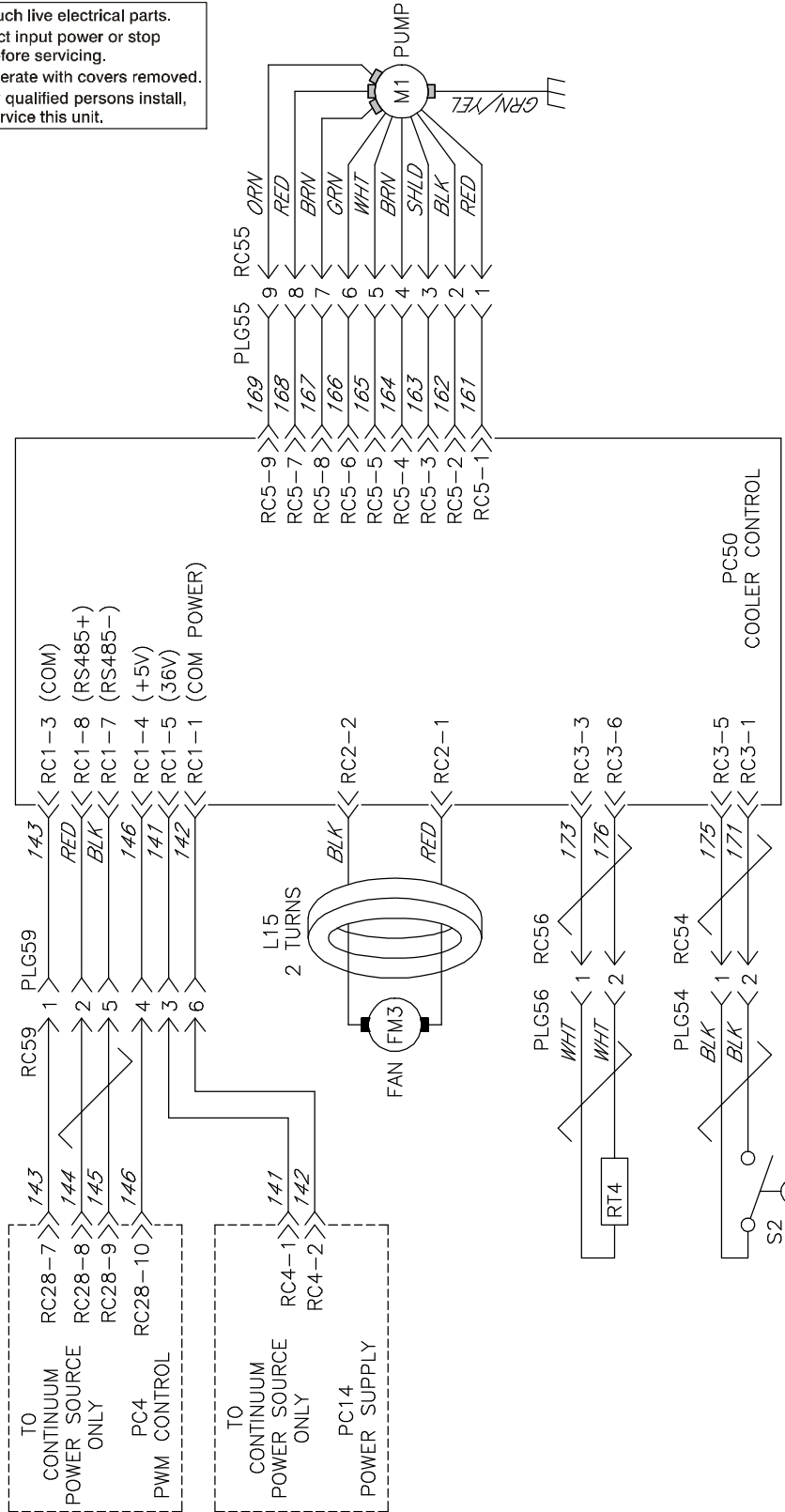

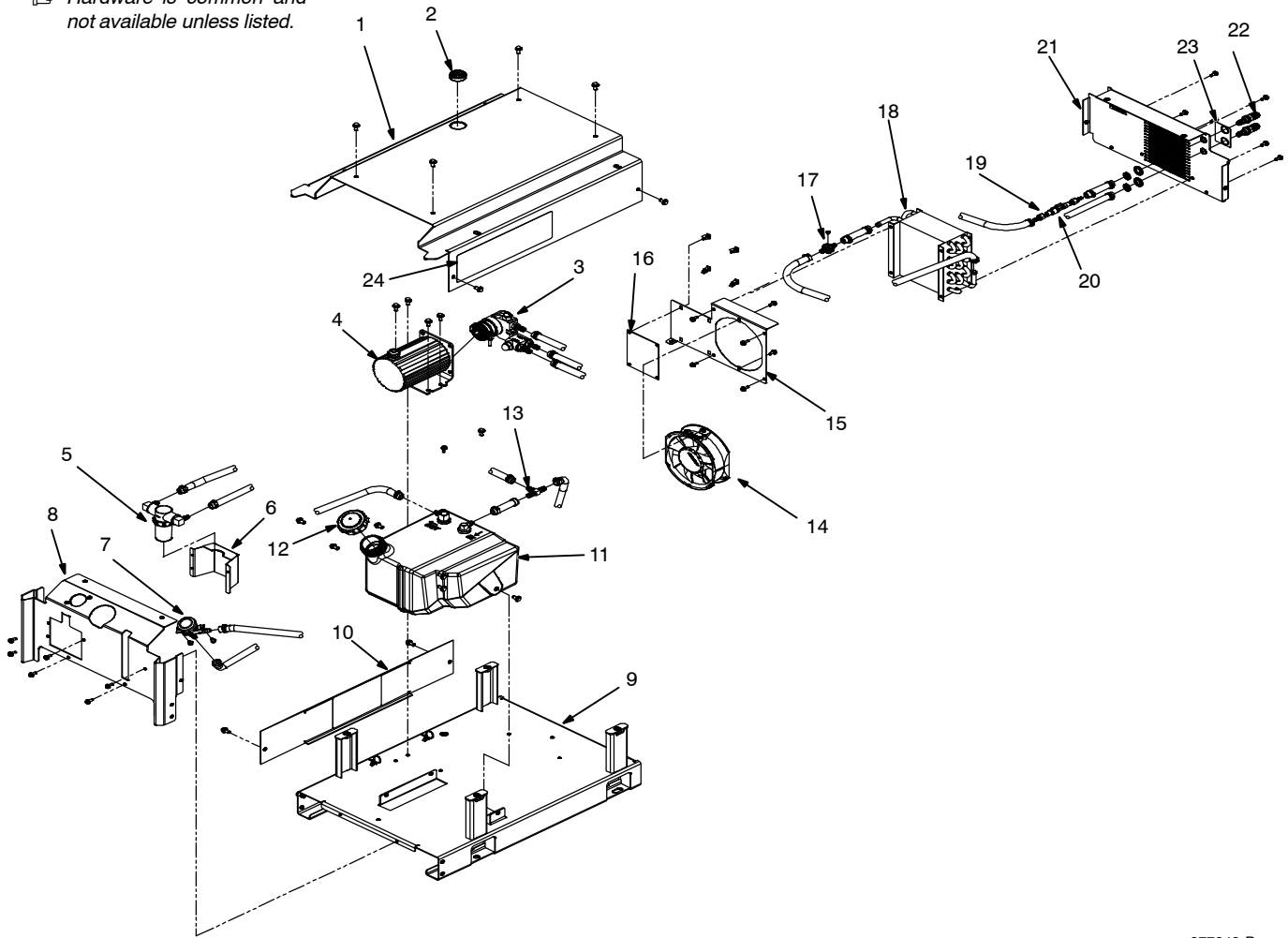

Figure 8-1. Circuit Diagram

SECTION 9 – PARTS LIST

 Hardware is common and not available unless listed.



277248-B

Figure 9-1. Cooler

Item No.	Dia. Mkgs.	Part No.	Description	Quantity
----------	------------	----------	-------------	----------

Figure 9-1. Cooler

...	1	...	+284564	Wrapper, Continuum Cooler	1
...	2	...	179276	Bushing, Snap-In Nyl 1.000 Id X 1.375 Mtg Hole Cent	1
...	3	...	274361	Pump Assy, 60gph W/Ftgs And Ext Bypass	1
...		...	126978	Ftg, Brs Barbed M 3/8 Tbg X 3/8 Npt	1
...	4	...	212743	Motor, 1/4 Hp 48VDC Bldc	1
...	5	...	274359	Filter, In-Line W/Fittings	1
...		...	271633	Screen, Filter Long 50 x 250 Micron Mesh Sst Caged	1
...	6	...	286490	Bracket, Filter	1
...	7	...	226934	Indicator, Flow	1
...	8	...	284566	Panel, Front	1
...		...	173632	Thermistor, Ntc 30k Ohm @ 25 Deg C 12.00in Lead	1
...	9	...	284525	Cooler, Base Assy Continuum	1
...	10	...	+284595	Panel, Lh Continuum Cooler	1
...	11	...	274374	Tank, Coolant	1
...	12	...	166608	Cap, Tank Screw-On W/Vent	1

Item No.	Dia. Mkgs.	Part No.	Description	Quantity
----------	------------	----------	-------------	----------

Figure 9-1. Cooler (Continued)

... 13		227851	. Ftg, Brs Barbed Tee 3/8 X3/8 X 3/8	1
		276795	. Clamp, 1-Ear Type Gap-Free 14.5-17 Mm Size	22
... 14		225166	. Fan, Muffin 24VDC 4000 Rpm 310 Cfm 6.378 Mtg Holes	1
... 15		274354	. Bracket, Heat Exchanger	1
... 16	PC50	272503	. Circuit Card Assy,Water Cooler Continuum W/Prog	1
... 17		275404	. Ftg, Hose Brs Adapter 3/8 Tbg X 3/8 Tbg W/ 6-32	1
... 18		232424	. Radiator, Heat Exchanger	1
		224263	. Core, Toroidal Nanocrystalline (32.7mm Diameter)	1
... 19		276878	. Ftg, Hose Brs Barbed Fem 3/8 Tbg X 3/8 Npt	2
... 20		274373	. Switch, Flow	1
... 21		+274352	. Panel, Rear	1
... 22		276274	. Ftg, Water Quick Conn .375 Female Panel Mount	2
... 23		276220	. Label, Water Fittings	1
... 24		277499	. Label, Warning Continuum Cooler	2

+When ordering a component originally displaying a precautionary label, the label should also be ordered.

To maintain the factory original performance of your equipment, use only Manufacturer's Suggested Replacement Parts. Model and serial number required when ordering parts from your local distributor.

TRUE BLUE[®]

WARRANTY

Effective January 1, 2019

(Equipment with a serial number preface of MK or newer)

This limited warranty supersedes all previous Miller warranties and is exclusive with no other guarantees or warranties expressed or implied.

LIMITED WARRANTY – Subject to the terms and conditions below, Miller Electric Mfg. LLC, Appleton, Wisconsin, warrants to authorized distributors that new Miller equipment sold after the effective date of this limited warranty is free of defects in material and workmanship at the time it is shipped by Miller. THIS WARRANTY IS EXPRESSLY IN LIEU OF ALL OTHER WARRANTIES, EXPRESS OR IMPLIED, INCLUDING THE WARRANTIES OF MERCHANTABILITY AND FITNESS.

Within the warranty periods listed below, Miller will repair or replace any warranted parts or components that fail due to such defects in material or workmanship. Miller must be notified in writing within thirty (30) days of such defect or failure, at which time Miller will provide instructions on the warranty claim procedures to be followed. Notifications submitted as online warranty claims must provide detailed descriptions of the fault and troubleshooting steps taken to diagnose failed parts. Warranty claims that lack the required information as defined in the Miller Service Operation Guide (SOG) may be denied by Miller.

Miller shall honor warranty claims on warranted equipment listed below in the event of a defect within the warranty coverage time periods listed below. Warranty time periods start on the delivery date of the equipment to the end-user purchaser, or 12 months after the equipment is shipped to a North American distributor, or 18 months after the equipment is shipped to an international distributor, whichever occurs first.

1. 5 Years Parts — 3 Years Labor
 - * Original Main Power Rectifiers Only to Include SCRs, Diodes, and Discrete Rectifier Modules
2. 3 Years — Parts and Labor Unless Specified
 - * Auto-Darkening Helmet Lenses (No Labor) (See Classic Series Exception Below)
 - * Engine Driven Welder/Generators
(NOTE: Engines are Warranted Separately by the Engine Manufacturer.)
 - * Insight Welding Intelligence Products
 - * Inverter Power Sources
 - * Plasma Arc Cutting Power Sources
 - * Process Controllers
 - * Semi-Automatic and Automatic Wire Feeders
 - * Transformer/Rectifier Power Sources
3. 2 Years — Parts and Labor
 - * Auto-Darkening Helmet Lenses – Classic Series Only (No Labor)
 - * Auto-Darkening Weld Masks (No Labor)
 - * Fume Extractors – Capture 5, Filtair 400 and Industrial Collector Series
4. 1 Year — Parts and Labor Unless Specified
 - * AugmentedArc and LiveArc Welding Systems
 - * Automatic Motion Devices
 - * Bernard BTB Air-Cooled MIG Guns (No Labor)
 - * CoolBelt and CoolBand Blower Unit (No Labor)
 - * Desiccant Air Dryer System
 - * Field Options
(NOTE: Field options are covered for the remaining warranty period of the product they are installed in, or for a minimum of one year — whichever is greater.)
 - * RFCS Foot Controls (Except RFCS-RJ45)
 - * Fume Extractors – Filtair 130, MWX and SWX Series HF Units
 - * ICE/XT Plasma Cutting Torches (No Labor)
 - * Induction Heating Power Sources, Coolers
(NOTE: Digital Recorders are Warranted Separately by the Manufacturer.)
 - * Load Banks
 - * Motor-Driven Guns (except Spoolmate Spoolguns)
 - * PAPR Blower Unit (No Labor)
 - * Positioners and Controllers
 - * Racks (For Housing Multiple Power Sources)
 - * Running Gear/Trailers
 - * Spot Welders

- * Subarc Wire Drive Assemblies
 - * TIG Torches (No Labor)
 - * Tregaskiss Guns (No Labor)
 - * Water Cooling Systems
 - * Wireless Remote Foot/Hand Controls and Receivers
 - * Work Stations/Weld Tables (No Labor)
5. 6 Months — Parts
 - * Batteries
 6. 90 Days — Parts
 - * Accessories (Kits)
 - * Canvas Covers
 - * Induction Heating Coils and Blankets, Cables, and Non-Electronic Controls
 - * M-Guns
 - * MIG Guns, Subarc (SAW) Torches, and External Cladding Heads
 - * Remote Controls and RFCS-RJ45
 - * Replacement Parts (No labor)
 - * Spoolmate Spoolguns

Miller's True Blue[®] Limited Warranty shall not apply to:

1. **Consumable components; such as contact tips, cutting nozzles, contactors, brushes, relays, work station table tops and welding curtains, or parts that fail due to normal wear. (Exception: brushes and relays are covered on all engine-driven products.)**
2. Items furnished by Miller, but manufactured by others, such as engines or trade accessories. These items are covered by the manufacturer's warranty, if any.
3. Equipment that has been modified by any party other than Miller, or equipment that has been improperly installed, improperly operated or misused based upon industry standards, or equipment which has not had reasonable and necessary maintenance, or equipment which has been used for operation outside of the specifications for the equipment.
4. Defects caused by accident, unauthorized repair, or improper testing.

MILLER PRODUCTS ARE INTENDED FOR COMMERCIAL AND INDUSTRIAL USERS TRAINED AND EXPERIENCED IN THE USE AND MAINTENANCE OF WELDING EQUIPMENT.

The exclusive remedies for warranty claims are, at Miller's option, either: (1) repair; or (2) replacement; or, if approved in writing by Miller, (3) the pre-approved cost of repair or replacement at an authorized Miller service station; or (4) payment of or credit for the purchase price (less reasonable depreciation based upon use). Products may not be returned without Miller's written approval. Return shipment shall be at customer's risk and expense.

The above remedies are F.O.B. Appleton, WI, or Miller's authorized service facility. Transportation and freight are the customer's responsibility. TO THE EXTENT PERMITTED BY LAW, THE REMEDIES HEREIN ARE THE SOLE AND EXCLUSIVE REMEDIES REGARDLESS OF THE LEGAL THEORY. IN NO EVENT SHALL MILLER BE LIABLE FOR DIRECT, INDIRECT, SPECIAL, INCIDENTAL OR CONSEQUENTIAL DAMAGES (INCLUDING LOSS OF PROFIT) REGARDLESS OF THE LEGAL THEORY. ANY WARRANTY NOT PROVIDED HEREIN AND ANY IMPLIED WARRANTY, GUARANTY, OR REPRESENTATION, INCLUDING ANY IMPLIED WARRANTY OF MERCHANTABILITY OR FITNESS FOR PARTICULAR PURPOSE, ARE EXCLUDED AND DISCLAIMED BY MILLER.

Some US states do not allow limiting the duration of an implied warranty or the exclusion of certain damages, so the above limitations may not apply to you. This warranty provides specific legal rights, and other rights may be available depending on your state. In Canada, some provinces provide additional warranties or remedies, and to the extent the law prohibits their waiver, the limitations set out above may not apply. This Limited Warranty provides specific legal rights, and other rights may be available, but may vary by province.

Warranty Questions?

Call
1-800-4-A-MILLER
for your local
Miller distributor.

Your distributor also gives
you ...

Service

You always get the fast,
reliable response you
need. Most replacement
parts can be in your
hands in 24 hours.

Support

Need fast answers to the
tough welding questions?
Contact your distributor.
The expertise of the
distributor and Miller is
there to help you, every
step of the way.





Owner's Record

Please complete and retain with your personal records.

Model Name

Serial/Style Number

Purchase Date

(Date which equipment was delivered to original customer.)

Distributor

Address

City

State

Zip



For Service

Contact a DISTRIBUTOR or SERVICE AGENCY near you.

Always provide Model Name and Serial/Style Number.

Contact your Distributor for:

Welding Supplies and Consumables

Options and Accessories

Personal Safety Equipment

Service and Repair

Replacement Parts

Training (Schools, Videos, Books)

Technical Manuals (Servicing Information and Parts)

Circuit Diagrams

Welding Process Handbooks

To locate a Distributor or Service Agency visit www.millerwelds.com or call 1-800-4-A-Miller

Contact the Delivering Carrier to:

File a claim for loss or damage during shipment.

For assistance in filing or settling claims, contact your distributor and/or equipment manufacturer's Transportation Department.

Miller Electric Mfg. LLC

An Illinois Tool Works Company
1635 West Spencer Street
Appleton, WI 54914 USA

International Headquarters—USA

USA Phone: 920-735-4505 Auto-Attended
USA & Canada FAX: 920-735-4134
International FAX: 920-735-4125

For International Locations Visit
www.MillerWelds.com

