



OM-227 398P

2015-03

**Processes**



MIG (GMAW) Welding

**Description**



Semi-Automatic, Air/Water-Cooled, MIG (GMAW) Welding Gun

# XR<sup>TM</sup> - AlumaPro

## (Air And Water-Cooled Guns)

### CE And Non-CE Models

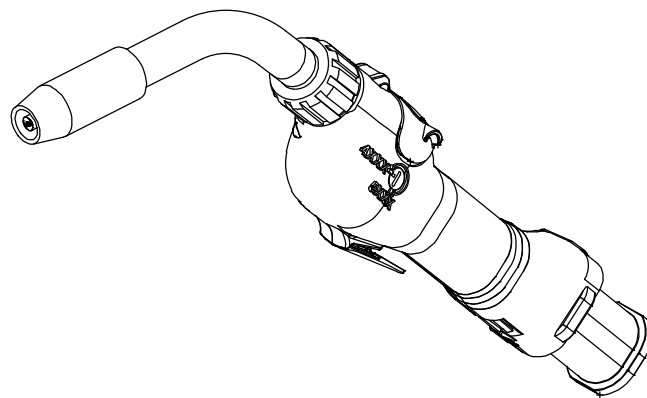

250 Ampere (Air) Push-Pull Welding Gun  
300 Ampere (Air) Push-Pull Welding Gun  
400 Ampere (Water) Push-Pull Welding Gun

# OWNER'S MANUAL



Visit our website at  
[www.MillerWelds.com](http://www.MillerWelds.com)

File: MIG (GMAW)



# From Miller to You

---

*Thank you and congratulations* on choosing Miller. Now you can get the job done and get it done right. We know you don't have time to do it any other way.

That's why when Niels Miller first started building arc welders in 1929, he made sure his products offered long-lasting value and superior quality. Like you, his customers couldn't afford anything less. Miller products had to be more than the best they could be. They had to be the best you could buy.

Today, the people that build and sell Miller products continue the tradition. They're just as committed to providing equipment and service that meets the high standards of quality and value established in 1929.

This Owner's Manual is designed to help you get the most out of your Miller products. Please take time to read the Safety precautions. They will help you protect yourself against potential hazards on the worksite.

We've made installation and operation quick and easy. With Miller you can count on years of reliable service with proper maintenance. And if for some reason the unit needs repair, there's a Troubleshooting section that will help you figure out what the problem is. The parts list will then help you to decide the exact part you may need to fix the problem. Warranty and service information for your particular model are also provided.



Miller is the first welding equipment manufacturer in the U.S.A. to be registered to the ISO 9001 Quality System Standard.

Miller Electric manufactures a full line of welders and welding related equipment. For information on other quality Miller products, contact your local Miller distributor to receive the latest full line catalog or individual specification sheets. **To locate your nearest distributor or service agency call 1-800-4-A-Miller, or visit us at [www.MillerWelds.com](http://www.MillerWelds.com) on the web.**



Working as hard as you do – every power source from Miller is backed by the most hassle-free warranty in the business.



# TABLE OF CONTENTS

<b>SECTION 1 – SAFETY PRECAUTIONS FOR GMAW WELDING GUNS – READ BEFORE USING</b> .....	<b>1</b>
1-1. Symbol Usage .....	1
1-2. Arc Welding Hazards .....	1
1-3. Proposition 65 Warnings .....	2
1-4. Principal Safety Standards .....	2
1-5. EMF Information .....	2
<b>SECTION 2 – MESURES DE SÉCURITÉ VISANT LES PISTOLETS DE SOUDAGE GMAW – À LIRE AVANT UTILISATION</b> .....	<b>1</b>
2-1. Signification des symboles .....	1
2-2. Dangers relatifs au soudage à l'arc .....	1
2-3. Proposition californienne 65 Avertissements .....	2
2-4. Principales normes de sécurité .....	2
2-5. Informations relatives aux CEM .....	2
<b>SECTION 3 – DEFINITIONS</b> .....	<b>5</b>
3-1. Additional Safety Symbols And Definitions .....	5
3-2. Miscellaneous Symbols And Definitions .....	5
<b>SECTION 4 – SPECIFICATIONS</b> .....	<b>6</b>
4-1. Specifications .....	6
4-2. Environmental Specifications .....	6
4-3. Duty Cycle And Overheating .....	7
<b>SECTION 5 – INSTALLATION</b> .....	<b>8</b>
5-1. Connections With A Constant Current (CC), Constant Voltage (CV) Or Constant Current/Constant Voltage (CC/CV) Welding Power Source Having A 14-socket Receptacle .....	8
5-2. Air-Cooled Gun Connections .....	9
5-3. Water-Cooled Gun Connections .....	10
5-4. Millermatic 350P Water Cooled Gun Connections .....	11
5-5. Threading Welding Wire For AlumaPro Gun And Millermatic 350P .....	12
5-6. Threading Welding Wire Through XR-Control Feeder .....	13
5-7. Adjusting Tension At Feeder .....	14
5-8. 10-Pin Plug Information .....	15
5-9. Opening Top Cover Of XR-AlumaPro Gun .....	15
5-10. Threading Welding Wire Through Gun .....	16
<b>SECTION 6 – OPERATION</b> .....	<b>17</b>
6-1. Gun Controls .....	17
6-2. Gun Pressure Roll Tension Setting .....	17
6-3. Shielding Gas .....	18
6-4. Coolant Supply For Water-Cooled Models Only .....	18
6-5. Gun Drive Assembly Maintenance For An XR-AlumaPro Gun .....	19
6-6. Replacing Head Tube Liner In XR-AlumaPro Guns .....	20
6-7. Changing Gun Contact Tip .....	20
6-8. Replacing The Gun Liner On XR-AlumaPro Guns .....	21
<b>SECTION 7 – MAINTENANCE &amp; TROUBLESHOOTING</b> .....	<b>22</b>
7-1. Routine Maintenance For Aluminum Push/Pull Guns .....	22
7-2. Cleaning The Gun Liner On XR-AlumaPro Guns .....	23
7-3. Troubleshooting Table .....	24
<b>SECTION 8 – ELECTRICAL DIAGRAMS</b> .....	<b>25</b>
<b>SECTION 9 – PARTS LIST</b> .....	<b>26</b>
<b>SECTION 10 – PARTS LIST INCLUDING CONSUMABLES</b> .....	<b>31</b>
<b>WARRANTY</b>	

# DECLARATION OF CONFORMITY



for European Community (CE marked) products.

**MILLER Electric Mfg. Co., 1635 Spencer Street, Appleton, WI 54914 U.S.A. declares that the product(s) identified in this declaration conform to the essential requirements and provisions of the stated Council Directive(s) and Standard(s).**

Product/Apparatus Identification:

Product	Stock Number
XR-A ALUMA-PRO	300000004, 300001004, 300264004, 300264006
XR-W ALUMA-PRO	300003, 300004, 300265
	300003002, 300004002, 300265002

Council Directives:

- 2006/95/EC Low Voltage
- 2011/65/EU Restriction of the use of certain hazardous substances in electrical and electronic equipment

Standards:

- IEC 60974-7:2013 Arc welding equipment – Part 7: Torches

Signatory:

March 25, 2015

---

**David A. Werba**

MANAGER, PRODUCT DESIGN COMPLIANCE

---

Date of Declaration

# SECTION 1 –SAFETY PRECAUTIONS FOR GMAW WELDING GUNS – READ BEFORE USING

SR7 (MIG) 2013-09

 **Protect yourself and others from injury — read, follow, and save these important safety precautions and operating instructions.**

## 1-1. Symbol Usage

 **DANGER!** – Indicates a hazardous situation which, if not avoided, will result in death or serious injury. The possible hazards are shown in the adjoining symbols or explained in the text.

 Indicates a hazardous situation which, if not avoided, could result in death or serious injury. The possible hazards are shown in the adjoining symbols or explained in the text.

**NOTICE** – Indicates statements not related to personal injury.

 Indicates special instructions.



This group of symbols means Warning! Watch Out! ELECTRIC SHOCK, MOVING PARTS, and HOT PARTS hazards. Consult symbols and related instructions below for necessary actions to avoid the hazards.

## 1-2. Arc Welding Hazards

 The symbols shown below are used throughout this manual to call attention to and identify possible hazards. When you see the symbol, watch out, and follow the related instructions to avoid the hazard. The safety information given below is only a summary of the more complete safety information found in the welding power source Owner's Manual. Read and follow all Safety Standards.

 Only qualified persons should install, operate, maintain, and repair this unit.

 During operation, keep everybody, especially children, away.

 **ELECTRIC SHOCK can kill.**

- Always wear dry insulating gloves.
- Insulate yourself from work and ground.
- Do not touch live electrode or electrical parts.

- Replace worn, damaged, or cracked guns or cables.
- Turn off welding power source before changing contact tip or gun parts.
- Keep all covers and handle securely in place.

 **FUMES AND GASES can be hazardous.**

- Keep your head out of the fumes.
- Ventilate area, or use breathing device. The recommended way to determine adequate ventilation is to sample for the composition and quantity of fumes and gases to which personnel are exposed.

- Read and understand the Safety Data Sheets (SDSs) and the manufacturer's instructions for adhesives, coatings, cleaners, consumables, coolants, degreasers, fluxes, and metals.

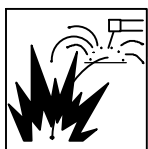
 **WELDING can cause fire or explosion.**

- Do not weld near flammable material.
- Do not weld on containers that have held combustibles, or on closed containers such as tanks, drums, or pipes unless they are properly prepared according to AWS F4.1 and AWS A6.0 (see Safety Standards).

- Watch for fire; keep extinguisher nearby.
- Read and understand the Safety Data Sheets (SDSs) and the manufacturer's instructions for adhesives, coatings, cleaners, consumables, coolants, degreasers, fluxes, and metals.

 **BUILDUP OF GAS can injure or kill.**

- Shut off compressed gas supply when not in use.
- Always ventilate confined spaces or use approved air-supplied respirator.

 **MOVING PARTS can injure.**

- Keep away from moving parts.
- Keep away from pinch points such as drive rolls.

 **ARC RAYS can burn eyes and skin.**

Arc rays from the welding process produce intense visible and invisible (ultraviolet and infrared) rays that can burn eyes and skin. Sparks fly off from the weld.

- Wear an approved welding helmet fitted with a proper shade of filter lenses to protect your face and eyes from arc rays and sparks when welding or watching (see ANSI Z49.1 and Z87.1 listed in Safety Standards).
- Wear approved safety glasses with side shields under your helmet.
- Use protective screens or barriers to protect others from flash, glare and sparks; warn others not to watch the arc.
- Wear body protection made from durable, flame-resistant material (leather, heavy cotton, wool). Body protection includes oil-free clothing such as leather gloves, heavy shirt, cuffless trousers, high shoes, and a cap.

 **HOT PARTS can burn.**

- Allow gun to cool before touching.
- Do not touch hot metal.
- Protect hot metal from contact by others.



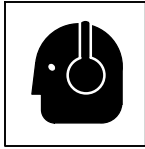

### NOISE can damage hearing.

Noise from some processes or equipment can damage hearing.

- Check for noise level limits exceeding those specified by OSHA.
- Use approved ear plugs or ear muffs if noise level is high.
- Warn others nearby about noise hazard.



### WELDING WIRE can injure.

- Keep hands and body away from gun tip when trigger is pressed.

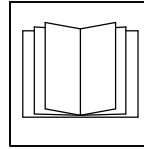

### READ INSTRUCTIONS.

- Read and follow all labels and the Owner's Manual carefully before installing, operating, or servicing unit. Read the safety information at the beginning of the manual and in each section.
- Use only genuine replacement parts from the manufacturer.
- Perform maintenance and service according to the Owner's Manuals, industry standards, and national, state, and local codes.

## 1-3. Proposition 65 Warnings

**⚠** Welding or cutting equipment produces fumes or gases which contain chemicals known to the State of California to cause birth defects and, in some cases, cancer. (California Health & Safety Code Section 25249.5 et seq.)

**⚠** This product contains chemicals, including lead, known to the state of California to cause cancer, birth defects, or other reproductive harm. *Wash hands after use.*

## 1-4. Principal Safety Standards

*Safety in Welding, Cutting, and Allied Processes*, ANSI Standard Z49.1, is available as a free download from the American Welding Society at <http://www.aws.org> or purchased from Global Engineering Documents (phone: 1-877-413-5184, website: [www.global.ihs.com](http://www.global.ihs.com)).

*Safe Practice For Occupational And Educational Eye And Face Protection*, ANSI Standard Z87.1, from American National Standards Institute, 25 West 43rd Street, New York, NY 10036 (phone: 212-642-4900, website: [www.ansi.org](http://www.ansi.org)).

*Safe Practices for the Preparation of Containers and Piping for Welding and Cutting*, American Welding Society Standard AWS F4.1, from Global Engineering Documents (phone: 1-877-413-5184, website: [www.global.ihs.com](http://www.global.ihs.com)).

*Safe Practices for Welding and Cutting Containers that have Held Combustibles*, American Welding Society Standard AWS A6.0, from Global Engineering Documents (phone: 1-877-413-5184, website: [www.global.ihs.com](http://www.global.ihs.com)).

*National Electrical Code*, NFPA Standard 70, from National Fire Protection Association, Quincy, MA 02269 (phone: 1-800-344-3555, website: [www.nfpa.org](http://www.nfpa.org) and [www.sparky.org](http://www.sparky.org)).

*Safe Handling of Compressed Gases in Cylinders*, CGA Pamphlet P-1, from Compressed Gas Association, 14501 George Carter Way, Suite 103, Chantilly, VA 20151 (phone: 703-788-2700, website: [www.cganet.com](http://www.cganet.com)).

*Safety in Welding, Cutting, and Allied Processes*, CSA Standard W117.2, from Canadian Standards Association, Standards Sales, 5060 Spectrum Way, Suite 100, Ontario, Canada L4W 5NS (phone: 800-463-6727, website: [www.csa-international.org](http://www.csa-international.org)).

*Safe Practice For Occupational And Educational Eye And Face Protection*, ANSI Standard Z87.1, from American National Standards Institute, 25 West 43rd Street, New York, NY 10036 (phone: 212-642-4900, website: [www.ansi.org](http://www.ansi.org)).

*Standard for Fire Prevention During Welding, Cutting, and Other Hot Work*, NFPA Standard 51B, from National Fire Protection Association, Quincy, MA 02269 (phone: 1-800-344-3555, website: [www.nfpa.org](http://www.nfpa.org)).

OSHA, Occupational Safety and Health Standards for General Industry, Title 29, Code of Federal Regulations (CFR), Part 1910, Subpart Q, and Part 1926, Subpart J, from U.S. Government Printing Office, Superintendent of Documents, P.O. Box 371954, Pittsburgh, PA 15250-7954 (phone: 1-866-512-1800) (there are 10 OSHA Regional Offices—phone for Region 5, Chicago, is 312-353-2220, website: [www.osha.gov](http://www.osha.gov)).

## 1-5. EMF Information

Electric current flowing through any conductor causes localized electric and magnetic fields (EMF). The current from arc welding (and allied processes including spot welding, gouging, plasma arc cutting, and induction heating operations) creates an EMF field around the welding circuit. EMF fields may interfere with some medical implants, e.g. pacemakers. Protective measures for persons wearing medical implants have to be taken. For example, restrict access for passers-by or conduct individual risk assessment for welders. All welders should use the following procedures in order to minimize exposure to EMF fields from the welding circuit:

1. Keep cables close together by twisting or taping them, or using a cable cover.
2. Do not place your body between welding cables. Arrange cables to one side and away from the operator.

3. Do not coil or drape cables around your body.
4. Keep head and trunk as far away from the equipment in the welding circuit as possible.
5. Connect work clamp to workpiece as close to the weld as possible.
6. Do not work next to, sit or lean on the welding power source.
7. Do not weld whilst carrying the welding power source or wire feeder.

### About Implanted Medical Devices:

Implanted Medical Device wearers should consult their doctor and the device manufacturer before performing or going near arc welding, spot welding, gouging, plasma arc cutting, or induction heating operations. If cleared by your doctor, then following the above procedures is recommended.

# SECTION 2 – MESURES DE SÉCURITÉ VISANT LES PISTOLETS DE SOUDAGE GMAW – À LIRE AVANT UTILISATION

SR7(MIG)\_2013-09 fre

**!** Pour écarter les risques de blessure pour vous-même et pour autrui — lire, appliquer et ranger en lieu sûr ces consignes relatives aux précautions de sécurité et au mode opératoire.

## 2-1. Signification des symboles



**DANGER!** – Indique une situation dangereuse qui si on l'évite pas peut donner la mort ou des blessures graves. Les dangers possibles sont montrés par les symboles joints ou sont expliqués dans le texte.



Indique une situation dangereuse qui si on l'évite pas peut donner la mort ou des blessures graves. Les dangers possibles sont montrés par les symboles joints ou sont expliqués dans le texte.

**NOTE** – Indique des déclarations pas en relation avec des blessures personnelles.

 Indique des instructions spécifiques.



Ce groupe de symboles veut dire Avertissement! Attention! DANGER DE CHOC ÉLECTRIQUE, PIÈCES EN MOUVEMENT, et PIÈCES CHAUDES. Consulter les symboles et les instructions ci-dessous y afférant pour les actions nécessaires afin d'éviter le danger.

## 2-2. Dangers relatifs au soudage à l'arc

**!** Les symboles présentés ci-après sont utilisés tout au long du présent manuel pour attirer votre attention et identifier les risques de danger. Lorsque vous voyez un symbole, soyez vigilant et suivez les directives mentionnées afin d'éviter tout danger. Les consignes de sécurité présentées ci-après ne font que résumer l'information contenue dans les normes de sécurité énumérées dans le manuel d'utilisation du poste de soudage. Veuillez lire et respecter toutes ces normes de sécurité.

**!** L'installation, l'utilisation, l'entretien et les réparations ne doivent être confiés qu'à des personnes qualifiées.

**!** Au cours de l'utilisation, tenir toute personne à l'écart et plus particulièrement les enfants.



### UN CHOC ÉLECTRIQUE peut tuer.

- Porter toujours des gants secs et isolants.
- S'isoler de la pièce et de la terre.
- Ne jamais toucher une électrode ou des pièces électriques sous tension.
- Remplacer les pistolets ou câbles de soudage qui sont endommagés, usés ou craquelés.
- Mettre la soudeuse hors tension avant de remplacer un bec contact ou des pièces de pistolet.
- S'assurer que tous les couvercles et poignées sont fermement assujettis.



### LES VAPEURS ET LES FUMÉES peuvent être nocives.

- Éloigner sa tête des endroits renfermant des vapeurs.
- Aérer la zone de travail ou porter un appareil respiratoire. Pour déterminer la bonne ventilation, il est recommandé de procéder à un prélèvement pour la composition et la quantité de fumées et de gaz auxquels est exposé le personnel.
- Lire et comprendre les fiches de données de sécurité et les instructions du fabricant concernant les adhésifs, les revêtements, les nettoyants, les consommables, les produits de refroidissement, les dégraisseurs, les flux et les métaux.



### LE SOUDAGE peut causer un incendie ou une explosion.

- Ne pas souder à proximité de matériaux inflammables.
- Ne pas effectuer le soudage sur des conteneurs fermés tels que des réservoirs, tambours, ou conduites, à moins qu'ils n'aient été préparés correctement conformément à AWS F4.1 et AWS A6.0 (voir les Normes de Sécurité).
- Prendre garde aux incendies et toujours avoir un extincteur à proximité.
- Lire et comprendre les fiches de données de sécurité et les instructions du fabricant concernant les adhésifs, les revêtements, les nettoyants, les consommables, les produits de refroidissement, les dégraisseurs, les flux et les métaux.



### L'ACCUMULATION DE VAPEURS peut causer des lésions ou la mort.

- Quand on n'utilise pas le gaz comprimé de protection, fermer le robinet de la bouteille.
- Assurer toujours la ventilation des zones fermées ou utiliser un appareil respiratoire avec alimentation en air.

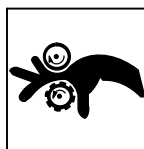

### Les PIÈCES MOBILES peuvent causer des blessures.

- Ne pas s'approcher des organes mobiles.
- Ne pas s'approcher des points de coincement tels que des rouleaux de commande.



### LE RAYONNEMENT DE L'ARC peut brûler les yeux et la peau.

Le rayonnement de l'arc du procédé de soudage génère des rayons visibles et invisibles intenses (ultraviolets et infrarouges) susceptibles de provoquer des brûlures dans les yeux et sur la peau. Des étincelles sont projetées pendant le soudage.

- Porter un casque de soudage approuvé muni de verres filtrants approprié pour protéger visage et yeux pendant le soudage (voir ANSI Z49.1 et Z87.1 énuméré dans les normes de sécurité).
- Porter des lunettes de sécurité avec écrans latéraux même sous votre casque.

- Avoir recours à des écrans protecteurs ou à des rideaux pour protéger les autres contre les rayonnements les éblouissements et les étincelles ; prévenir toute personne sur les lieux de ne pas regarder l'arc.
- Porter un équipement de protection pour le corps fait d'un matériau résistant et ignifuge (cuir, coton robuste, laine). La protection du corps comporte des vêtements sans huile comme par ex. des gants de cuir, une chemise solide, des pantalons sans revers, des chaussures hautes et une casquette.



### LES PIÈCES CHAUDES peuvent provoquer des brûlures.

- Laisser refroidir le pistolet avant de le toucher.
- Ne pas toucher d'objets métalliques chauds.
- Abriter les objets métalliques contre tout contact par les personnes à proximité.



### Le BRUIT peut endommager l'ouïe.

Le bruit des processus et des équipements peut affecter l'ouïe.

- Vérifier si les niveaux de bruit excèdent les limites spécifiées par l'OSHA.

- Utiliser des bouche-oreilles ou des serre-tête antibruit approuvés si le niveau de bruit est élevé.
- Avertir les personnes à proximité au sujet du danger inhérent au bruit.

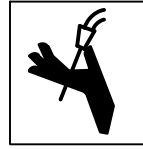

### LES FILS DE SOUDAGE peuvent provoquer des blessures.

- Éloigner les mains et le corps de la buse du pistolet après avoir appuyé sur la gâchette.

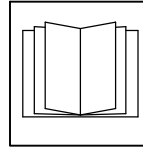

### LIRE LES INSTRUCTIONS.

- Lire et appliquer les instructions sur les étiquettes et le Mode d'emploi avant l'installation, l'utilisation ou l'entretien de l'appareil. Lire les informations de sécurité au début du manuel et dans chaque section.

- N'utiliser que les pièces de rechange recommandées par le constructeur.
- Effectuer l'entretien en respectant les manuels d'utilisation, les normes industrielles et les codes nationaux, d'état et locaux.

## 2-3. Proposition californienne 65 Avertissements

**⚠ Les équipements de soudage et de coupage produisent des fumées et des gaz qui contiennent des produits chimiques dont l'État de Californie reconnaît qu'ils provoquent des malformations congénitales et, dans certains cas, des cancers. (Code de santé et de sécurité de Californie, chapitre 25249.5 et suivants)**

**⚠ Ce produit contient des éléments chimiques, dont le plomb, reconnu par l'État de Californie pour leur caractère cancérigène ainsi que provoquant des malformations congénitales ou autres problèmes de procréation. Se laver les mains après toute manipulation.**

## 2-4. Principales normes de sécurité

*Safety in Welding, Cutting, and Allied Processes*, ANSI Standard Z49.1, is available as a free download from the American Welding Society at <http://www.aws.org> or purchased from Global Engineering Documents (phone: 1-877-413-5184, website: [www.global.ihs.com](http://www.global.ihs.com)).

*Safe Practice For Occupational And Educational Eye And Face Protection*, ANSI Standard Z87.1, from American National Standards Institute, 25 West 43rd Street, New York, NY 10036 (phone: 212-642-4900, website: [www.ansi.org](http://www.ansi.org)).

*Safe Practices for the Preparation of Containers and Piping for Welding and Cutting*, American Welding Society Standard AWS F4.1, from Global Engineering Documents (phone: 1-877-413-5184, website: [www.global.ihs.com](http://www.global.ihs.com)).

*Safe Practices for Welding and Cutting Containers that have Held Combustibles*, American Welding Society Standard AWS A6.0, from Global Engineering Documents (phone: 1-877-413-5184, website: [www.global.ihs.com](http://www.global.ihs.com)).

*National Electrical Code*, NFPA Standard 70, from National Fire Protection Association, Quincy, MA 02269 (phone: 1-800-344-3555, website: [www.nfpa.org](http://www.nfpa.org) and [www.sparky.org](http://www.sparky.org)).

*Safe Handling of Compressed Gases in Cylinders*, CGA Pamphlet P-1, from Compressed Gas Association, 14501 George Carter Way, Suite

103, Chantilly, VA 20151 (phone: 703-788-2700, website: [www.cganet.com](http://www.cganet.com)).

*Safety in Welding, Cutting, and Allied Processes*, CSA Standard W117.2, from Canadian Standards Association, Standards Sales, 5060 Spectrum Way, Suite 100, Ontario, Canada L4W 5N5 (phone: 800-463-6727, website: [www.csa-international.org](http://www.csa-international.org)).

*Safe Practice For Occupational And Educational Eye And Face Protection*, ANSI Standard Z87.1, from American National Standards Institute, 25 West 43rd Street, New York, NY 10036 (phone: 212-642-4900, website: [www.ansi.org](http://www.ansi.org)).

*Standard for Fire Prevention During Welding, Cutting, and Other Hot Work*, NFPA Standard 51B, from National Fire Protection Association, Quincy, MA 02269 (phone: 1-800-344-3555, website: [www.nfpa.org](http://www.nfpa.org)).

OSHA, Occupational Safety and Health Standards for General Industry, Title 29, Code of Federal Regulations (CFR), Part 1910, Subpart Q, and Part 1926, Subpart J, from U.S. Government Printing Office, Superintendent of Documents, P.O. Box 371954, Pittsburgh, PA 15250-7954 (phone: 1-866-512-1800) (there are 10 OSHA Regional Offices—phone for Region 5, Chicago, is 312-353-2220, website: [www.osha.gov](http://www.osha.gov)).

## 2-5. Informations relatives aux CEM

Le courant électrique qui traverse tout conducteur génère des champs électromagnétiques (CEM) à certains endroits. Le courant de soudage crée un CEM autour du circuit et du matériel de soudage. Le courant issu d'un soudage à l'arc (et de procédés connexes, y compris le soudage par points, le gougeage, le découpage plasma et les opérations de chauffage par induction) crée un champ électromagnétique(CEM) autour du circuit de soudage. Des mesures de protection pour les porteurs d'implants médicaux doivent être prises: Limiter par exemple tout accès aux passants ou procéder à une évaluation des risques individuels pour les soudeurs. Tous les

soudeurs doivent appliquer les procédures suivantes pour minimiser l'exposition aux CEM provenant du circuit de soudage:

- 1 Rassembler les câbles en les torsadant ou en les attachant avec du ruban adhésif ou avec une housse.
- 2 Ne pas se tenir au milieu des câbles de soudage. Disposer les câbles d'un côté et à distance de l'opérateur.
- 3 Ne pas courber et ne pas entourer les câbles autour de votre corps.



- 4 Maintenir la tête et le torse aussi loin que possible du matériel du circuit de soudage.
- 5 Connecter la pince sur la pièce aussi près que possible de la soudure.
- 6 Ne pas travailler à proximité d'une source de soudage, ni s'asseoir ou se pencher dessus.

- 7 Ne pas souder tout en portant la source de soudage ou le dévidoir.

**En ce qui concerne les implants médicaux :**



Les porteurs d'implants doivent d'abord consulter leur médecin avant de s'approcher des opérations de soudage à l'arc, de soudage par points, de gougeage, du coupage plasma ou de chauffage par induction. Si le médecin approuve, il est recommandé de suivre les procédures précédentes.









# SECTION 3 – DEFINITIONS







## 3-1. Additional Safety Symbols And Definitions







Some symbols are found only on CE products.

	<p>Warning! Watch Out! There are possible hazards as shown by the symbols.</p> <p style="text-align: right;"><small>Safe1 2012-05</small></p>
	<p>Do not discard product (where applicable) with general waste. Reuse or recycle Waste Electrical and Electronic Equipment (WEEE) by disposing at a designated collection facility. Contact your local recycling office or your local distributor for further information.</p> <p style="text-align: right;"><small>Safe37 2012-05</small></p>

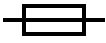
## 3-2. Miscellaneous Symbols And Definitions

<b>V</b>	Volts
	Alternating Current
<b>X</b>	Duty Cycle
	Wire Feed
	Gun
	Trigger Hold Off
	Run-In
	Read Instructions
	Water (Coolant) Input
<b>A</b>	Amperes

	Circuit Breaker
	Trigger
	Trigger Hold On
<b>%</b>	Percent
<b>U<sub>2</sub></b>	Load Voltage
	Line Connection
	Continuous Spot Welding
<b>Hz</b>	Hertz
	Output
	Increase

	Spot Weld Time
<b>U<sub>1</sub></b>	Primary Voltage
<b>I<sub>2</sub></b>	Rated Current
	Fuse
<b>IP</b>	Degree Of Protection
	Jog
	Press To Set
	Purge
	Burnback Time
<b>I<sub>1</sub></b>	Primary Current
	Water (Coolant) Output

## Notes

---

---

---

---

---

---

---

---

---

---

---

---

---

---

---

---

---

---

---

---

---

---

---

---

# SECTION 4 – SPECIFICATIONS

## 4-1. Specifications

Model	Welding Output Range	Electrode Wire Diameter Capacity	Wire Feed Speed Range	Net Weight (Torch Only)
(CE Models) XR-A AlumaPro 15 ft (4.7 m) XR-A AlumaPro 25 ft (7.6 m) XR-A AlumaPro 35 ft (10.7 m)	250 A at 60% Duty Cycle	.030 To 1/16 in. (0.8 To 1.6 mm) aluminum wire	70 To 900 ipm (1.8 To 23 mpm)	2.5 lb (1.1 kg) (less cables)
(Non CE Models) XR-A AlumaPro 15 ft (4.7 m) XR-A AlumaPro 25 ft (7.6 m) XR-A AlumaPro 35 ft (10.7 m)	300 A at 100% Duty Cycle	.030 To 1/16 in. (0.8 To 1.6 mm) aluminum wire	70 To 900 ipm (1.8 To 23 mpm)	2.5 lb (1.1 kg) (less cables)
(CE And Non CE Models) XR-W AlumaPro 15 ft (4.7 m) XR-W AlumaPro 25 ft (7.6 m) XR-W AlumaPro 35 ft (10.7 m)	400 A at 100% Duty Cycle	.030 To 1/16 in. (0.8 To 1.6 mm) aluminum wire	70 To 900 ipm (1.8 To 23 mpm)	2.9 lb (1.3 kg) (less cables)

 When using 1/16 in (1.6 mm) wire, kit 230708 must be installed.

## 4-2. Environmental Specifications

### A. IP Rating

<b>IP Rating</b>
IP3X
This equipment is designed for indoor use and is not intended to be used or stored outside.
IP3X 2014-06

### B. Information On Electromagnetic Fields (EMF)

 **This equipment shall not be used by the general public as the EMF limits for the general public might be exceeded during welding.**

This equipment is built in accordance with EN 60974-1 and is intended to be used only in an occupational environment (where the general public access is prohibited or regulated in such a way as to be similar to occupational use) by an expert or an instructed person.

Wire feeders and ancillary equipment (such as torches, liquid cooling systems and arc striking and stabilizing devices) as part of the welding circuit may not be a major contributor to the EMF. See the Owner's Manuals for all components of the welding circuit for additional EMF exposure information.

- The EMF assessment on this equipment was conducted at 0.5 meter.
- At a distance of 1 meter the EMF exposure values were less than 20% of the permissible values.

ce-emf 1 2010-10

# Notes

---

---

---

---

---

---

---

---

---

---

---

---

---

---

---

---

---

---

---

---

---

---

---

---

---

---

---

## 4-3. Duty Cycle And Overheating



Duty Cycle is percentage of 10 minutes that unit can weld at rated load without overheating.

**NOTICE** – Exceeding duty cycle can damage unit and void warranty.

### Air-Cooled Models (CE)

60% Duty Cycle At 250 Peak Amperage Using 100% Argon Gas w/15, 25 Or 35 Foot Guns

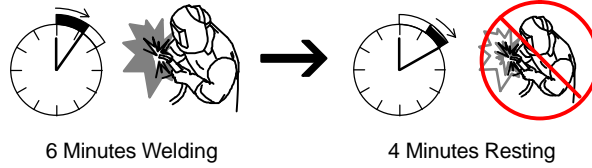

### Air-Cooled Models

100% Duty Cycle At 300 Peak Amperage Using 100% Argon Gas w/15, 25 Or 35 Foot Guns



### Water-Cooled Models (CE)

100% Duty Cycle At 400 Peak Amperage Using 100% Argon Gas w/15, 25 Or 35 Foot Guns



sduty1 5/95

## Notes

---



---



---



---



---



---



---



---



---



---



---



---

# SECTION 5 – INSTALLATION

☞ Be sure that contact tip, liner, and drive rolls are correct for wire size and type. See Parts List to change parts as needed.

## 5-1. Connections With A Constant Current (CC), Constant Voltage (CV) Or Constant Current/Constant Voltage (CC/CV) Welding Power Source Having A 14-Socket Receptacle

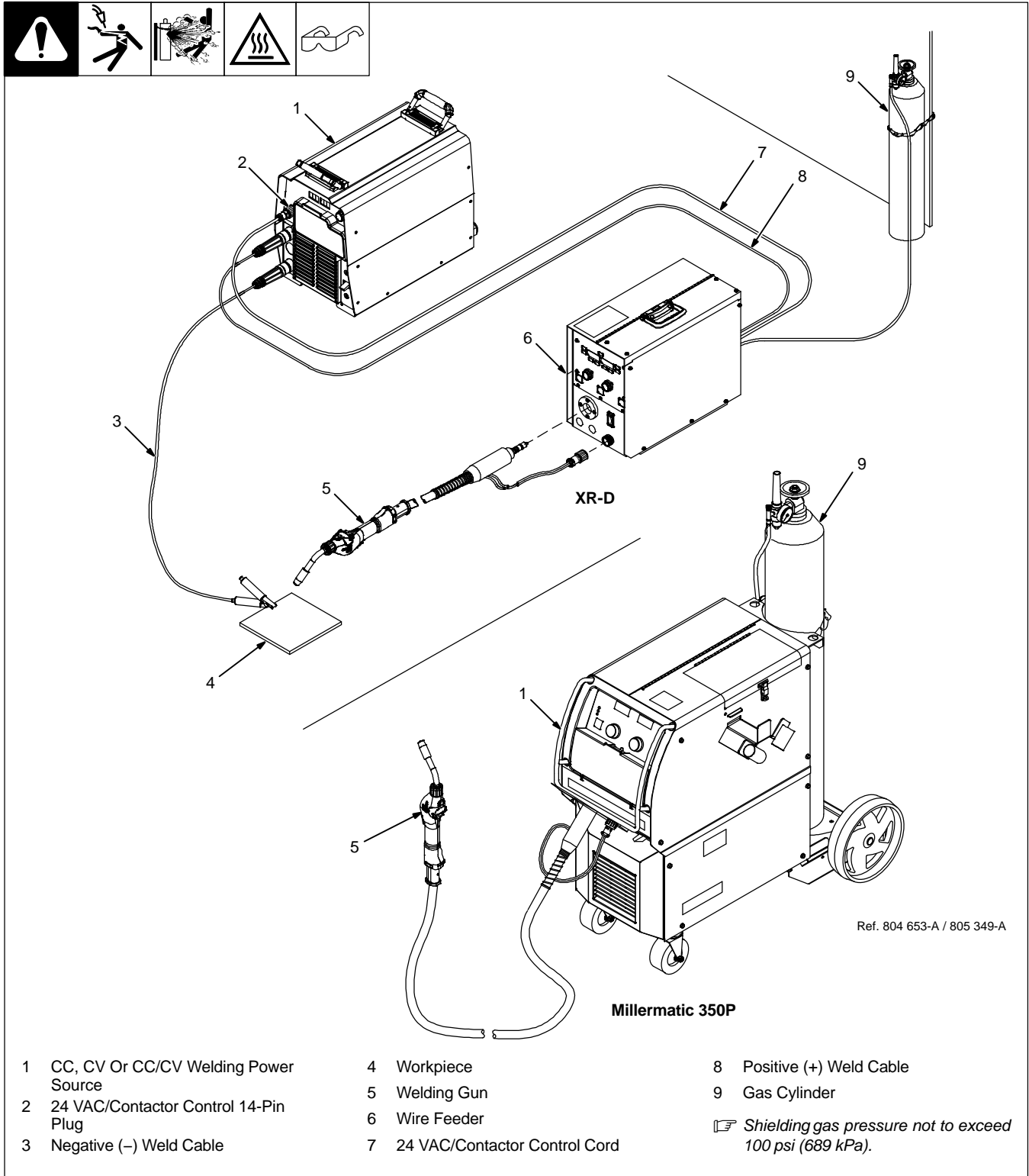

## 5-2. Air-Cooled Gun Connections



1 Gun Control Cable  
Insert plug into Gun Control receptacle, and tighten threaded collar.

2 Gun Power Pin

3 Gun Bushing

4 Gun Securing Knob

5 Drive Casting

Loosen gun securing knob and insert gun power pin through gun bushing until it bottoms against drive casting. Tighten knob.

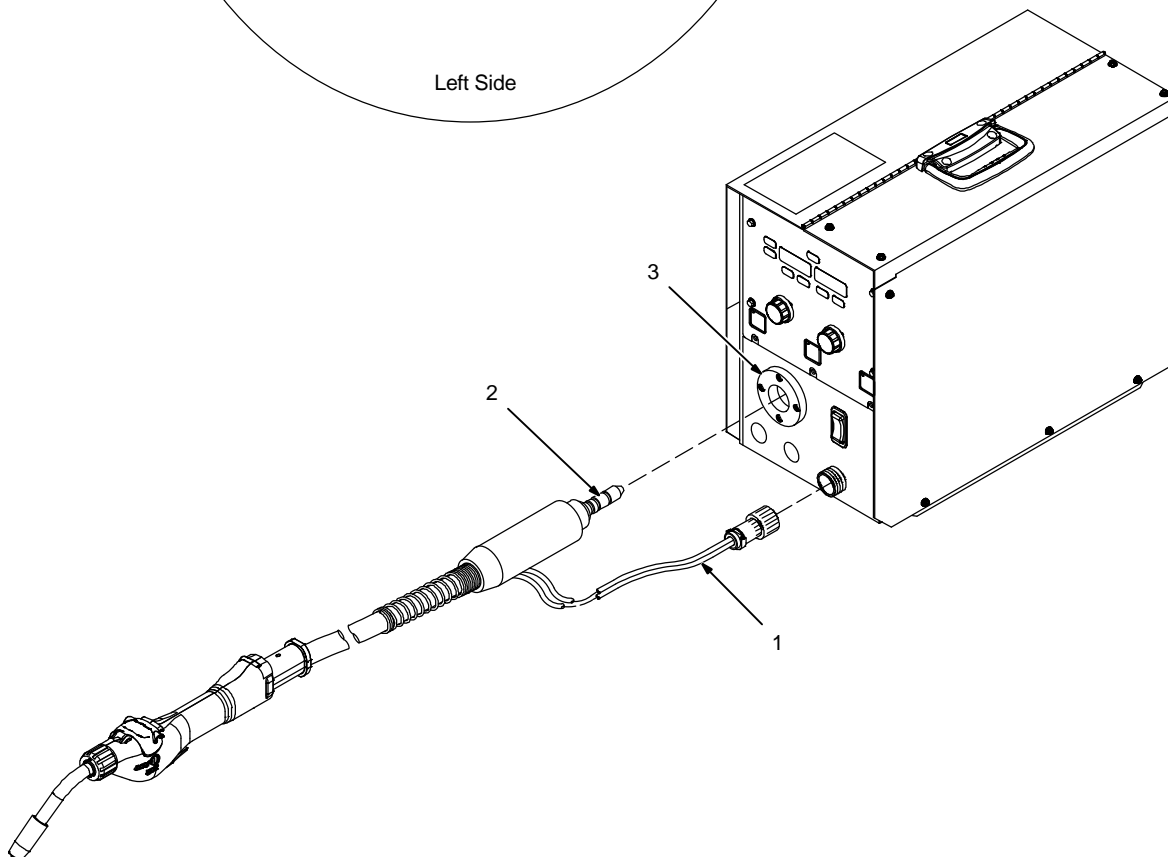
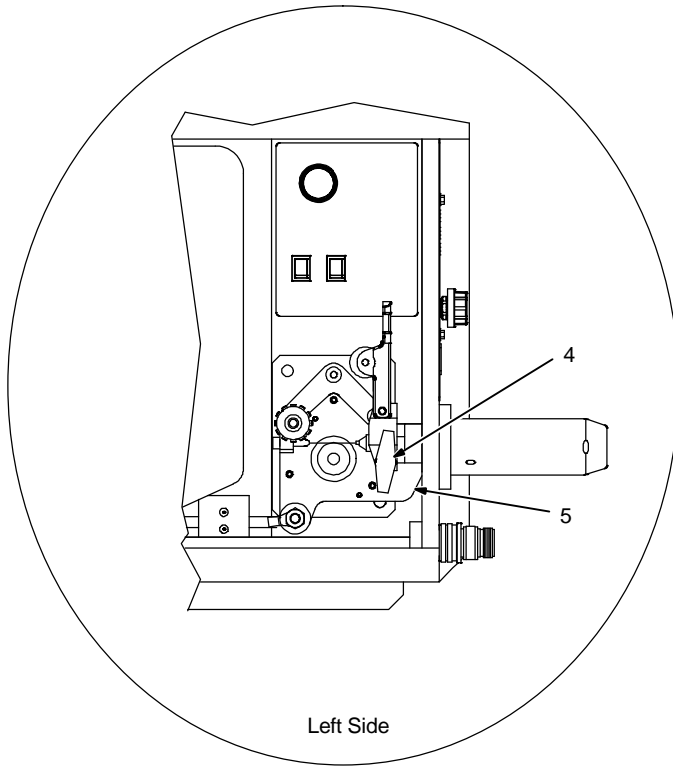

### 5-3. Water-Cooled Gun Connections

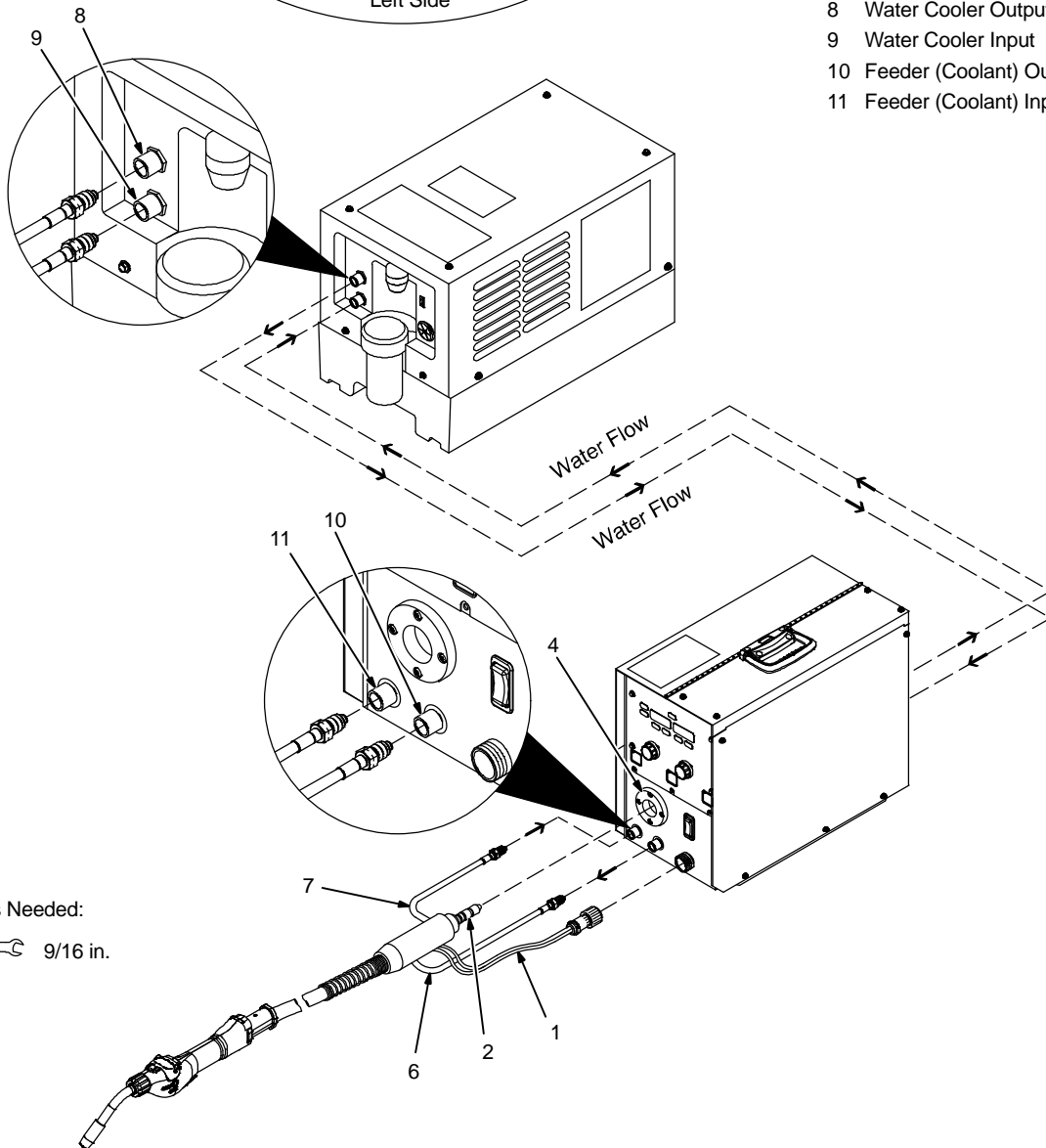
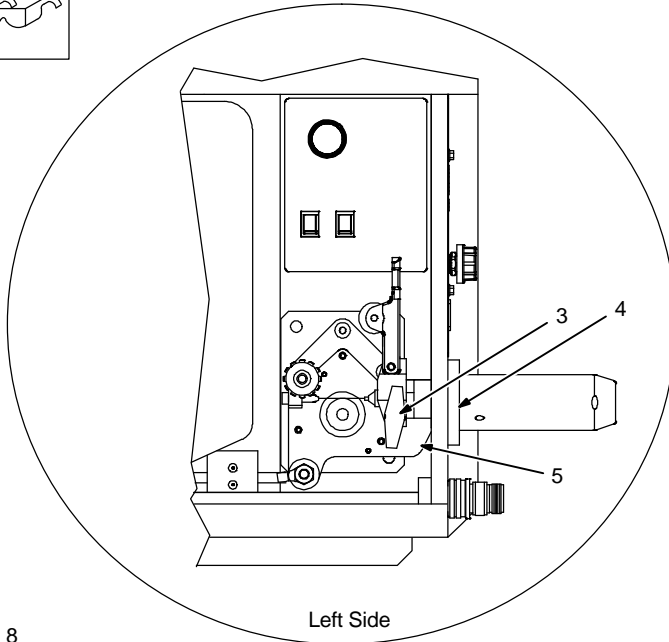

☞ Turn on coolant supply before welding or gun will be damaged.

1 Gun Control Cable

Insert plug into Gun Control receptacle, and tighten threaded collar.

2 Gun Power Pin

3 Gun Securing Knob

4 Gun Bushing

5 Drive Casting

Loosen gun securing knob, and insert gun power pin through gun bushing until it bottoms against drive casting. Tighten knob. Close and latch door.

6 Gun (Coolant) "In" Hose

Connect to Water "Out" fitting on feeder (left-hand threads).

7 Gun (Coolant) "Out" Hose

Connect to Water "In" fitting on feeder (left-hand threads)

8 Water Cooler Output

9 Water Cooler Input

10 Feeder (Coolant) Output

11 Feeder (Coolant) Input

Tools Needed:





## 5-4. Millermatic 350P Water Cooled Gun Connections

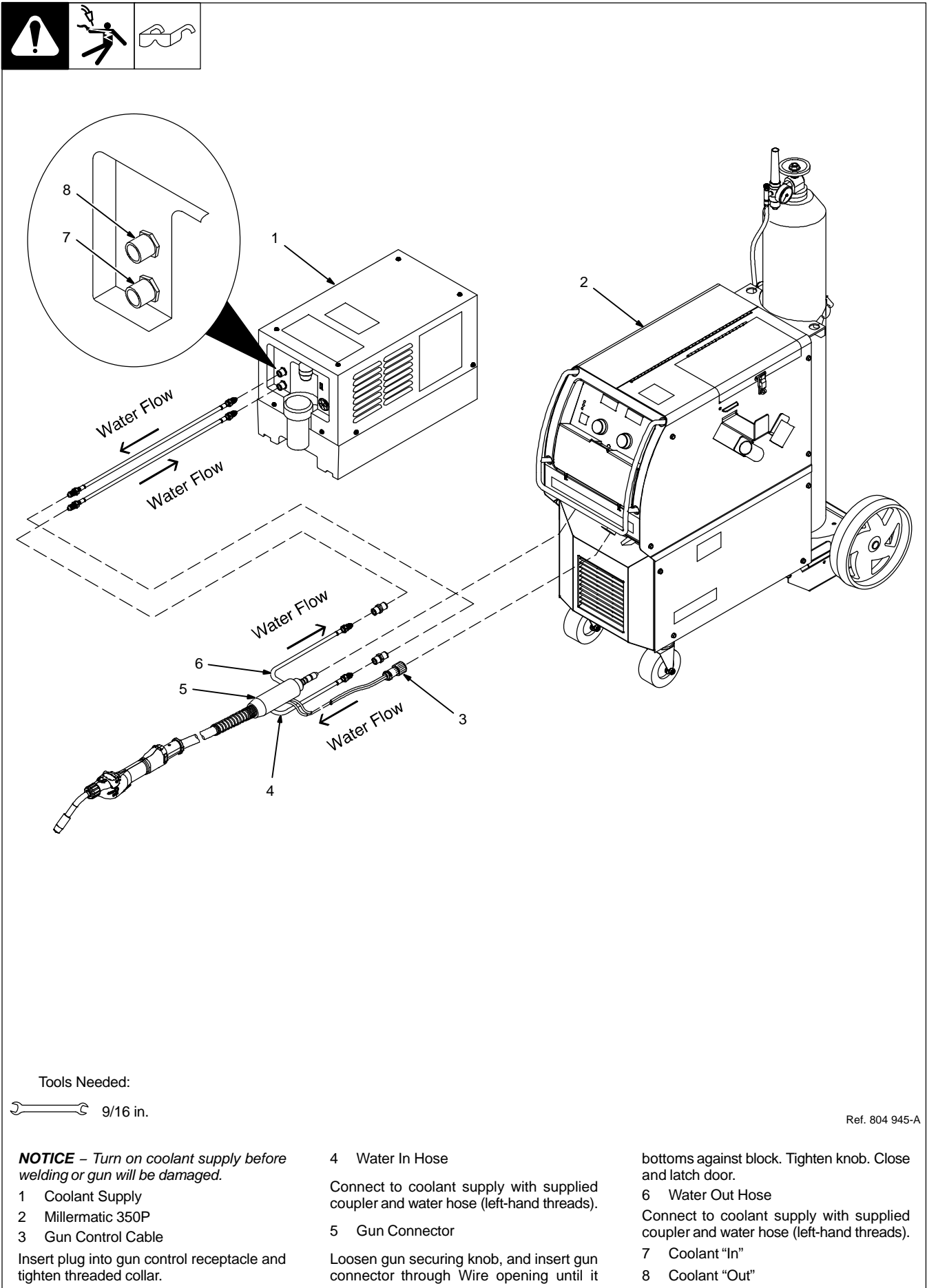

Tools Needed:

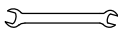
 9/16 in.

Ref. 804 945-A

**NOTICE** – Turn on coolant supply before welding or gun will be damaged.

- 1 Coolant Supply
- 2 Millermatic 350P
- 3 Gun Control Cable

Insert plug into gun control receptacle and tighten threaded collar.

- 4 Water In Hose

Connect to coolant supply with supplied coupler and water hose (left-hand threads).

- 5 Gun Connector

Loosen gun securing knob, and insert gun connector through Wire opening until it

bottoms against block. Tighten knob. Close and latch door.

- 6 Water Out Hose

Connect to coolant supply with supplied coupler and water hose (left-hand threads).

- 7 Coolant "In"

- 8 Coolant "Out"

## 5-5. Threading Welding Wire For AlumaPro Gun And Millermatic 350P

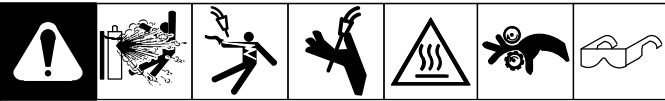

- 1 Wire Spool
  - 2 Welding Wire
  - 3 Inlet Wire Guide
  - 4 Drive Roll
  - 5 Intermediate Wire Guide
  - 6 Outlet Wire Guide
  - 7 Pressure Adjustment Knob
  - 8 Gun Conduit Cable
- Lay gun cable out straight.

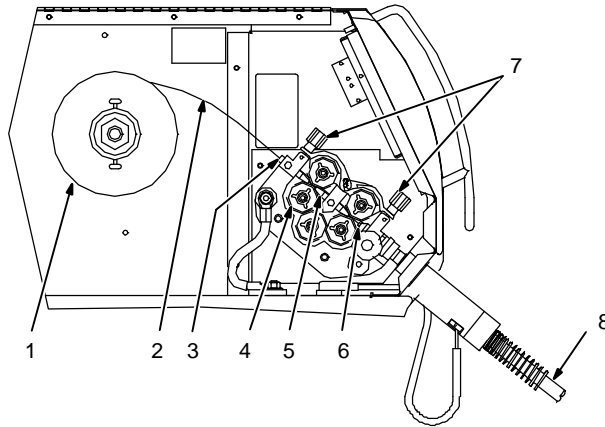

Tools Needed:

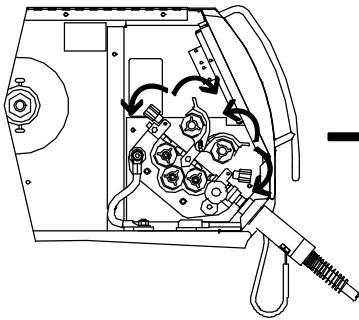
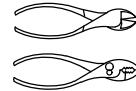

Open pressure assembly.



3/4 in.

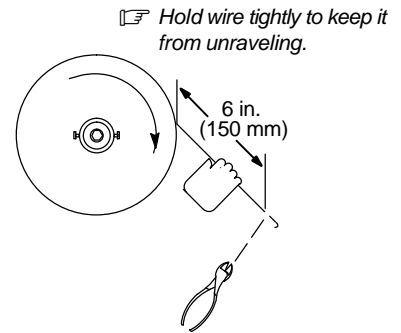

Pull and hold wire; cut off end.

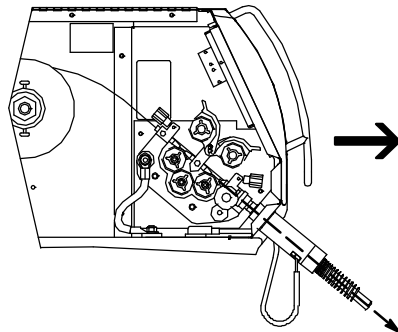

Push wire thru guides into gun; continue to hold wire.

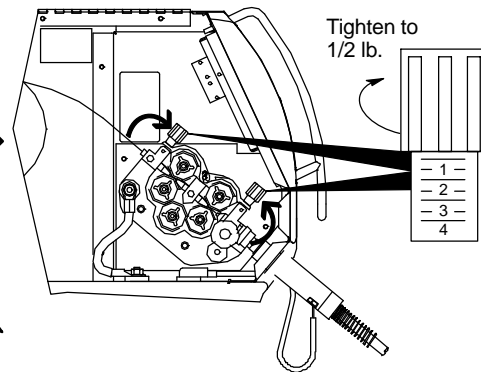

Close and tighten pressure assembly, and let go of wire.

Set pressure indicator scale to 1/2 lb.

Pressure Indicator Scale



See Section 5-10 for threading welding wire through AlumaPro guns.



## 5-7. Adjusting Tension At Feeder

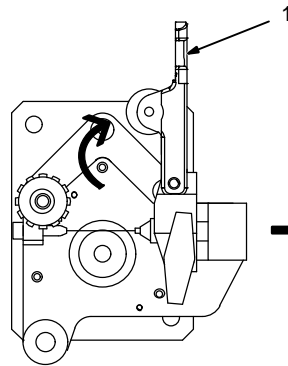
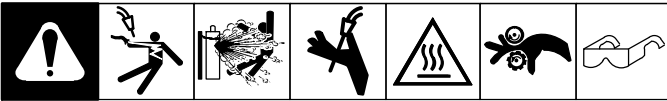

1 Tension Arm  
Open tension arm.

☞ Hold wire tightly to keep it from unraveling.

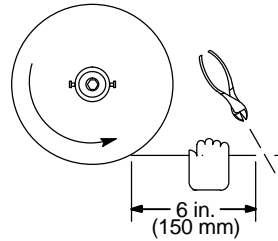

Pull and hold wire; cut off end.

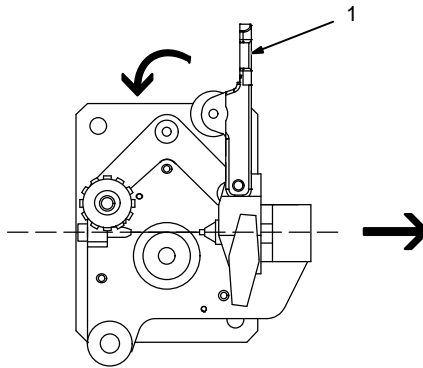

Install proper size drive rolls.

Thread wire thru inlet guide, along drive roll groove, and into wire conduit. Close tension arm. **Adjust tension as follows:**

### Tension Settings

Wire Size	Welding	Gun Calibration
0.035 in.	1-2	3-4
0.040 in.	3-4	
3/64 in.		
1/16 in.		

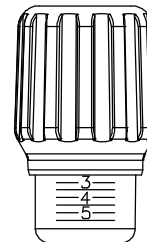



Tools Needed:

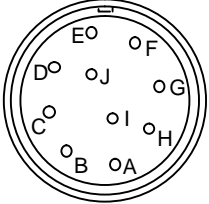

## 5-8. 10-Pin Plug Information

 REMOTE 10	Pin*	Pin Information
	A	Electrode sense lead
	B	Motor Common
	G	Trigger
	C	Motor 0 to +24 volts DC with respect to pin B
	D	Trigger
	E	Wire speed Ref. +9 volts DC
	H	Wire speed com
	F	Wire speed 0 to +9 volts DC with respect to pin H
	J	Gun sensing resistor with respect to pin H
	I	Not used

## 5-9. Opening Top Cover Of XR-AlumaPro Gun

1 Top Cover

Squeeze sides of cover and lift up as shown.

To close cover, pivot cover closed on gun, and push cover down until cover locks tight.

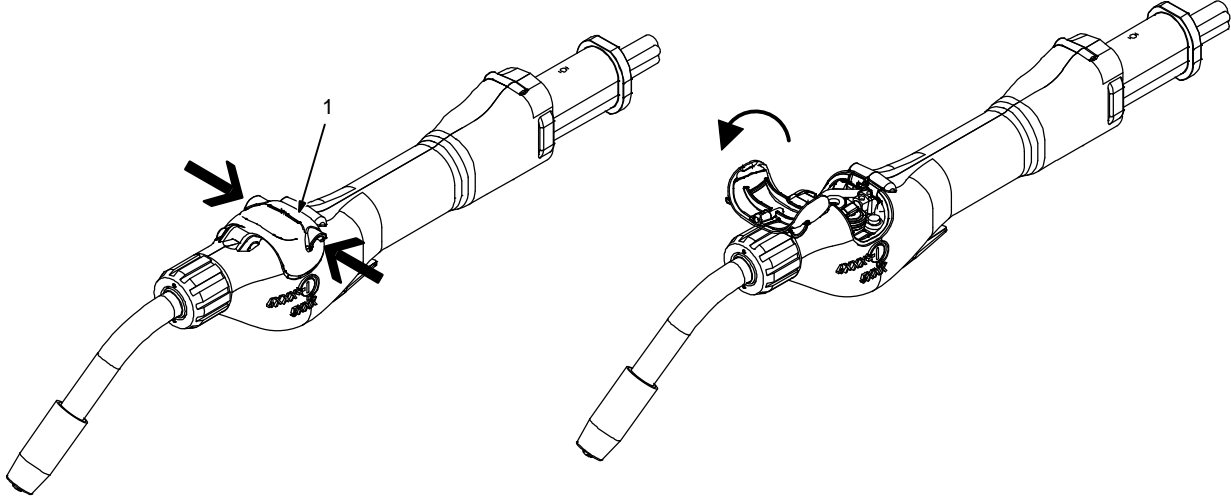

Ref. 804 544-B

## 5-10. Threading Welding Wire Through Gun

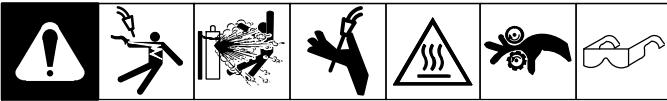

☞ Refer to Section 5-5 for instructions on feeding wire through feeder.

For XR-AlumaPro Gun:

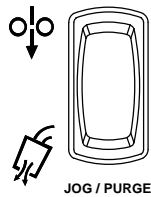
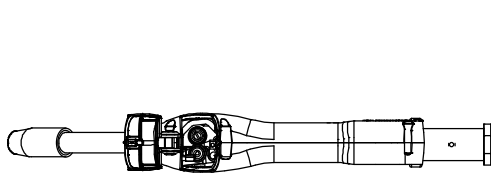

⚠ Welding wire is electrically live when gun trigger is used to jog wire.

☞ Turn OFF coolant supply before threading wire through gun..

Lay gun cable out straight. Press Jog switch until about 6 in. (152 mm) of wire is sticking out end of contact tip.

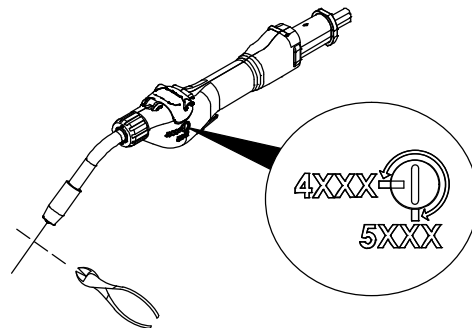

☞ Verify pressure adjustment on handle matches the wire type. See Section 6-2.

Cut off wire. Close and latch wire feeder door.

Tools Needed:



Ref. 804 544-B / 804 545-B

# SECTION 6 – OPERATION

## 6-1. Gun Controls

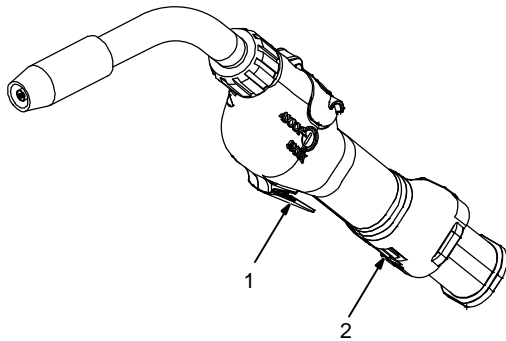

### 1 Trigger

Press trigger to energize welding power source contactor (if applicable), start shielding gas flow, and begin wire feed.

Switches inside the wire feeder can be set to provide timed shielding gas preflow and postflow when trigger is pressed and released. When this feature is turned Off, no preflow or postflow is provided for the welding operation.

### 2 Gun Wire Speed Control

Use control to fine adjust wire feed speed set on XR-Control. Gun Wire Speed Control has 3-3/4 turns of adjustment from minimum to maximum.

Rotate control clockwise to increase wire speed and counterclockwise to decrease wire speed.

*Speed control can be rotated more than 3-3/4 turns in both directions without being damaged.*

Ref. 804 545-B

## 6-2. Gun Pressure Roll Tension Setting

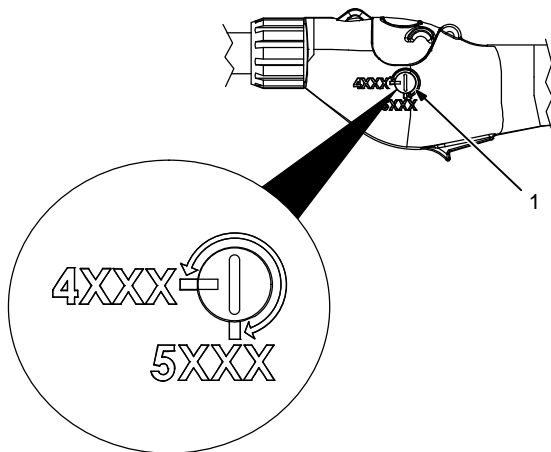

*Aluminum series specific - Pressure roll tension setting ensures smooth wire feeding action.*

*Gun Pressure Roll Tension is factory set to 4XXX.*

### 1 Pressure Roll Adjustment Screw

Wire tension should be set to 4XXX for 4000 series aluminum wire.

Rotate Pressure Roll Adjustment Screw fully counterclockwise until indicator line on adjustment knob lines up with indicator line on handle in the 4XXX position.

Wire tension should be set to 5XXX for 5000 series aluminum and stainless wire.

Rotate Pressure Roll Adjustment Screw fully clockwise until indicator line on adjustment knob lines up with indicator line on handle in the 5XXX position.

Tools Needed:



Ref. 804 545-B

### 6-3. Shielding Gas

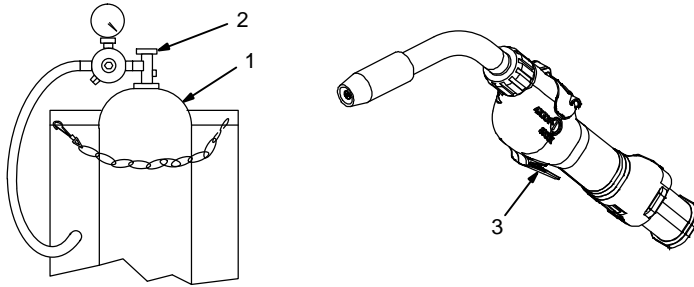

- 1 Shielding Gas Cylinder
- 2 Valve
- 3 Gun Trigger

Open valve on cylinder just before welding.

Gun trigger turns weld output and gas flow on and off (see Section 6-1).

Close valve on cylinder when finished welding.

Ref. 151 666-F / 804 545-B

### 6-4. Coolant Supply For Water-Cooled Models Only

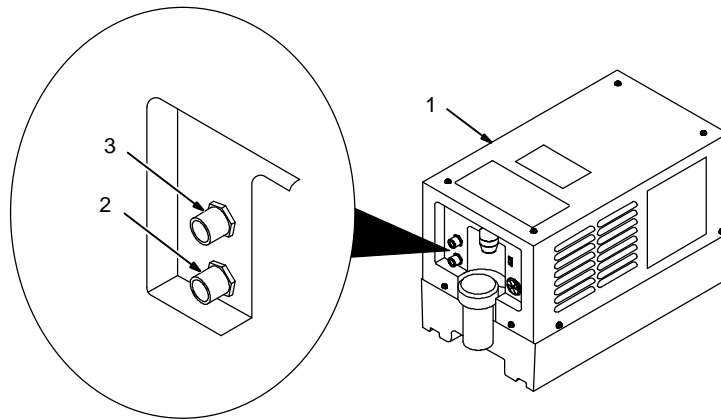

- 1 Coolant Supply
- 2 Coolant "In"
- 3 Coolant "Out"

See table below for coolant guidelines.

Turn On coolant supply before welding.

Turn Off coolant supply when finished welding.

Application	GMAW Or Where Coolant Contacts Aluminum Parts Or Where HF* Not Used	Requirement of Coolant Supply Water-Cooled Models Only
 Coolant	MILLER Aluminum Protecting Coolant No. 043 809*; Distilled Or Deionized Water OK Above 32° F (0° C)	Minimum flow rate: 0.13 G/min (0.5 L/min) Minimum inlet pressure: 40 psi (276 kPa) Maximum inlet pressure: 70 psi (483 kPa) Minimum cooling power: 1000 Watt (3410 BTU/hr)

\*MILLER coolants protect to -37° F (-38°C) and resist algae growth.

Ref. 150 755-A



## 6-5. Gun Drive Assembly Maintenance For An XR-AlumaPro Gun

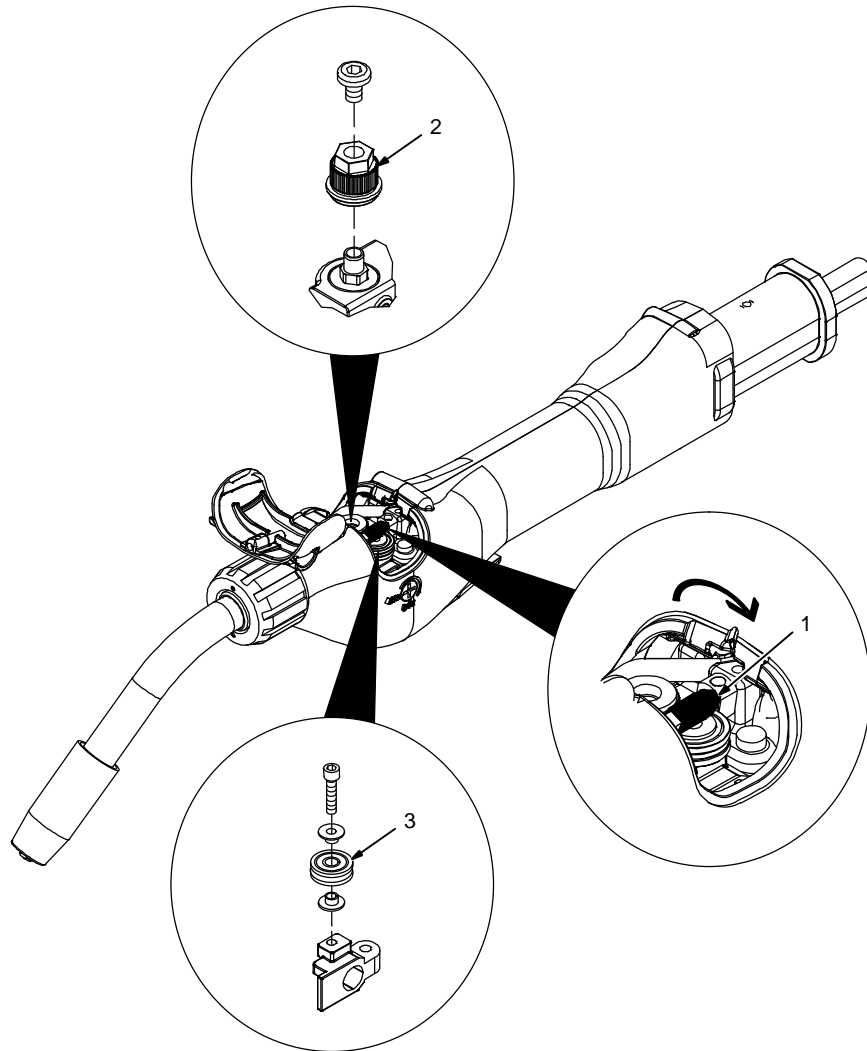
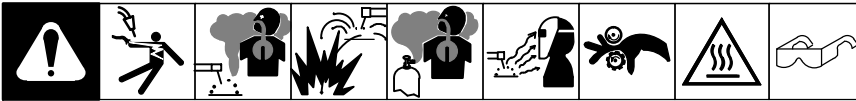

### 1 Lever Arm

Using lever arm open pressure roll with bearing as shown.

Retract wire onto spool.

### 2 Drive Roll

Use wire brush to clean drive roll. Install drive roll with hex opening down toward shaft hex, and secure with screw.

### 3 Pressure Roll

Thread welding wire through gun. Close pressure roll assembly and idler roll (located in XR control box). Press jog switch until wire is sticking out end of contact tip.

*When changing wire size and using an XR control box you should change the control box drive roll and idler. See XR owners manual for details.*

Close top cover.

Tools Needed:

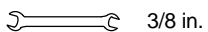
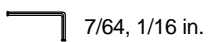

Ref. 804 544-B / 805 194-A

## 6-6. Replacing Head Tube Liner In XR-AlumaPro Guns

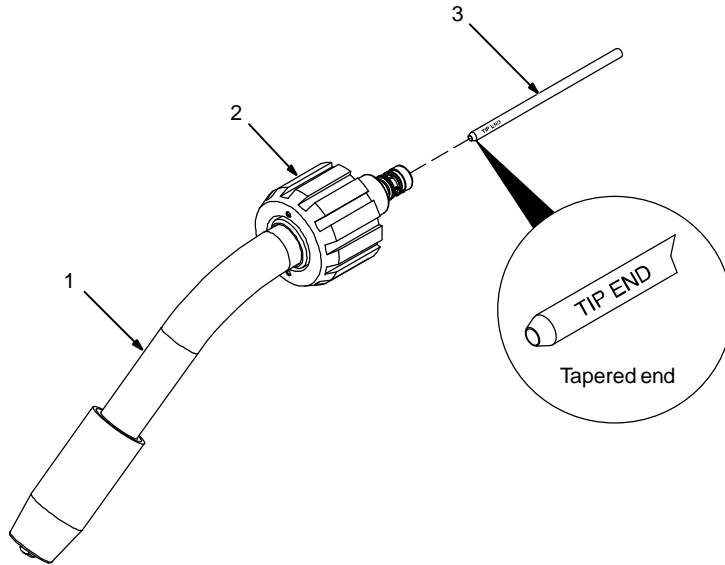
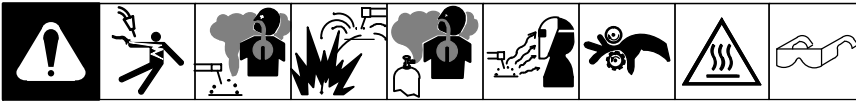

☞ Turn OFF coolant supply before removing head tube on water-cooled gun.

The standard head tube liner (yellow) will accommodate wire diameters from 3/64 in.- 1/16 in. wire size.

When changing wire size, change control box drive roll, idler and head tube liner with appropriate sized liner.

- 1 Head Tube
- 2 Head Tube Nut
- 3 Head Tube Liner

Loosen head tube nut and remove head tube from gun.

Pull liner out of head tube.

Insert new liner into head tube (install tapered end first) and reinstall head tube onto gun.

☞ A twisting motion may be needed to feed liner thru head tube.

**NOTICE** – Be sure head tube is seated and head tube nut is securely tightened before operating gun. If head tube nut is not adequately tightened, unwanted arcing may occur between head tube and gun housing.

Ref. 804 544-B

## 6-7. Changing Gun Contact Tip

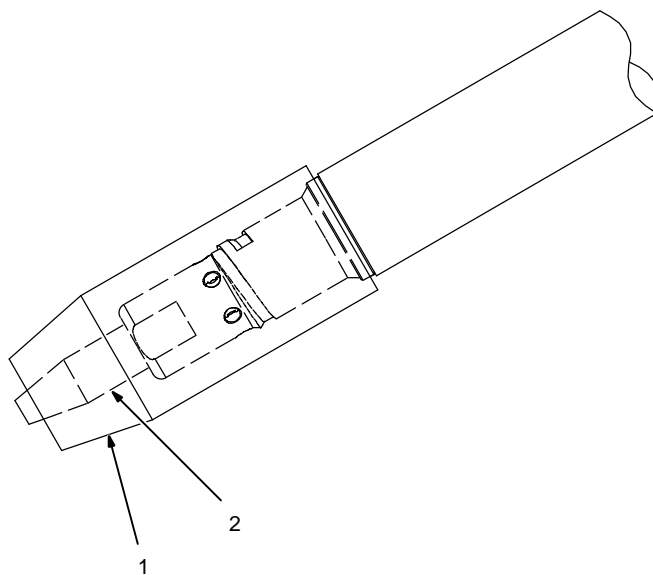

Remove nozzle

- 1 Nozzle
- 2 FasTip

Unscrew FasTip.

Install new FasTip.

**NOTICE** – Make sure correct size contact tip is being used. Incorrect size may cause arcing inside tip, poor feedability and poor arc starting characteristics(see Section 9).

Reinstall nozzle.

Ref. 804 709-A

## 6-8. Replacing The Gun Liner On XR-AlumaPro Guns

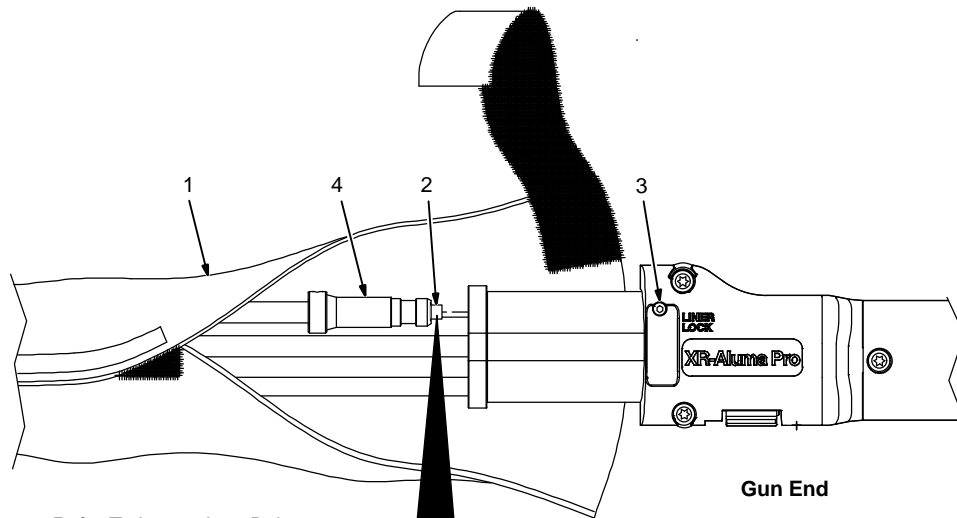

Refer To Instructions Below.

Remove Old Liner (Item 2) From Gun End →  
Install New Liner (Item 2) Into Gun End ←

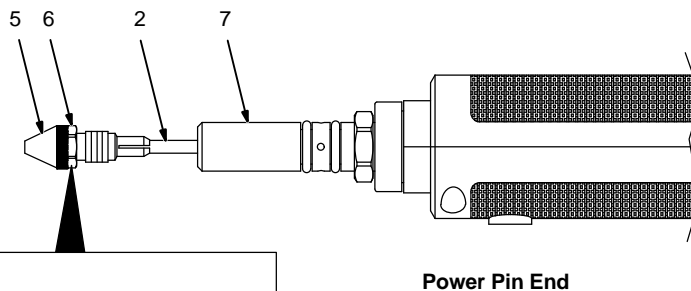

Power Pin End

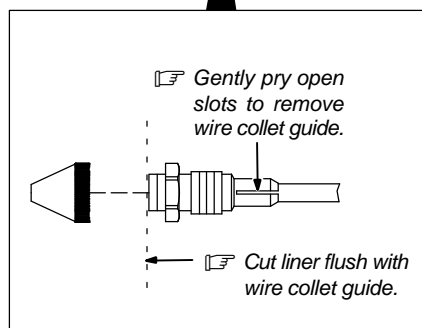

Gently pry open slots to remove wire collet guide.

Cut liner flush with wire collet guide.

Ref. 804 546-A

### ⚠ Turn Off welding power source and wire feeder.

- 1 Leather Cover
- 2 Liner
- 3 Liner Lock Allen Screw
- 4 Liner Guide Reducer
- 5 Wire Guide Cone
- 6 Wire Collet Guide
- 7 Power Pin

Lay gun cable out straight.

Remove short leather cover to access liner assembly.

Loosen liner lock allen screw (located near back of handle) to remove liner guide reducer from gun.

Remove wire guide cone and wire collet guide from power pin.

Remove old liner from gun end (see illustration above).

Insert new liner into gun end and continue feeding liner through cable assembly until

liner is through power pin assembly and is visible.

Install liner assembly into gun and firmly tighten (do not over tighten) liner lock allen screw.

Reinstall wire collet guide at power pin and tighten onto liner.

Cut liner off flush with wire collet guide. Reinstall wire guide cone.

Refer to Owner's Manual for instructions on rethreading wire.

# SECTION 7 – MAINTENANCE & TROUBLESHOOTING

## 7-1. Routine Maintenance For Aluminum Push/Pull Guns

						<b>Disconnect power before maintaining.</b>
--	--	--	--	--	--	---

	✔ = Check	● = Clean	★ = Replace			
Daily						
	✔ ● Head Tube Liner and Drive Casting (see Section 6-6)					
Weekly						
	✔ ● Drive Roll					
Every Spool of Wire						
	✔ ● Nozzle / Contact Tip	● Gun Casing	✔ ● Gun Liner (see Section 7-2)			
Every 3 Months						
	★ Unreadable Labels	● Weld Terminals	✔ ★ Weld Cable			
	✔ 14-Pin Cord	✔ Gas Hose and Fittings	✔ Gun Cable			

## 7-2. Cleaning The Gun Liner On XR-AlumaPro Guns

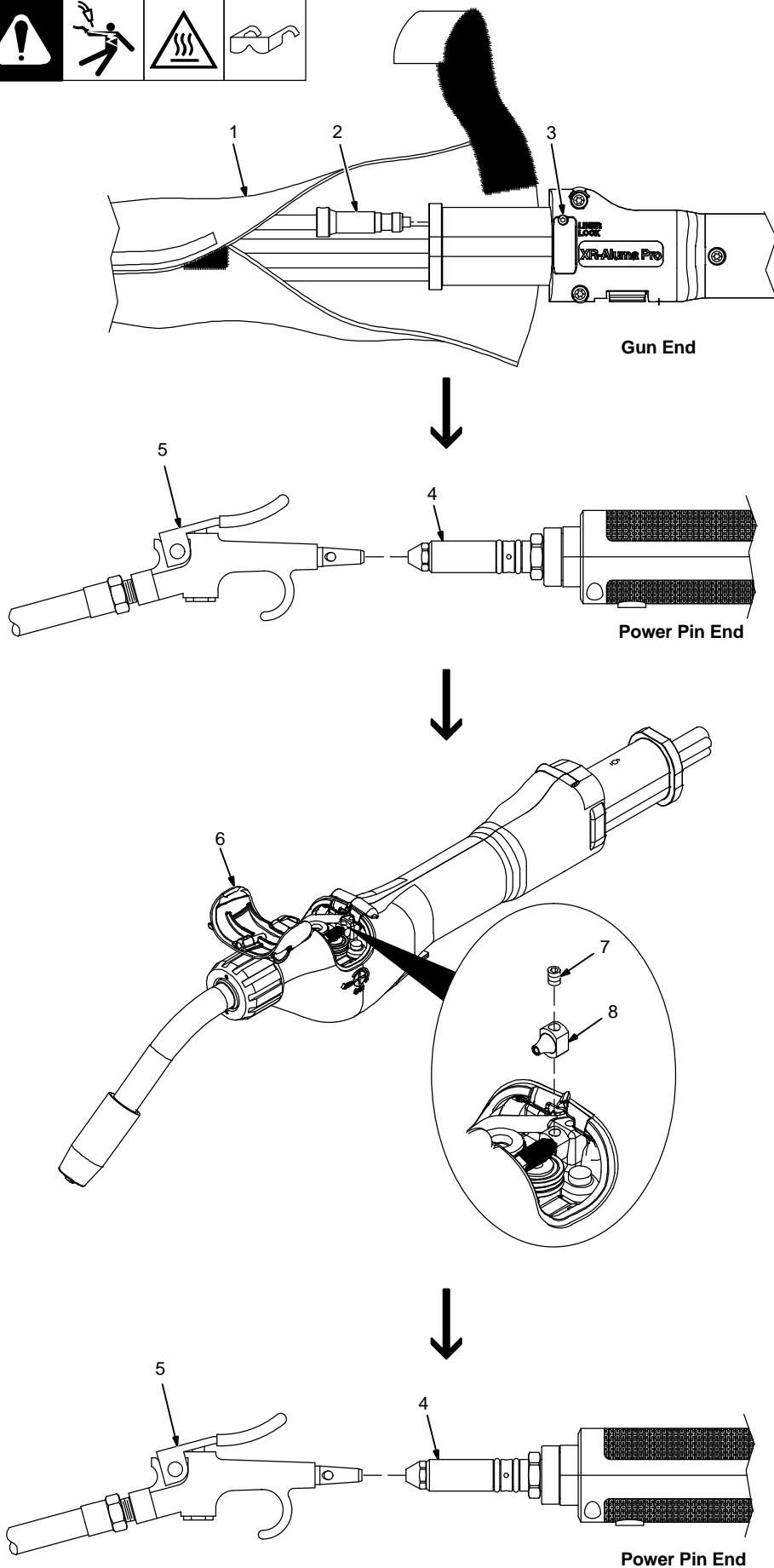

**⚠ Turn Off welding power source and wire feeder.**

**NOTICE** – Clean gun liner before cleaning stainless tube and inlet guide.

Lay gun cable out straight.

1 Leather Cover

Remove leather cover to access liner assembly.

2 Liner Guide Reducer

3 Liner Lock Allen Screw

4 Power Pin

5 Air Nozzle

Loosen liner lock allen screw (located near back of handle) to remove liner guide reducer from gun.

Blow air from power pin end through liner until clean of debris.

Reinstall liner assembly into gun and firmly tighten (do not overtighten) liner lock allen screw when finished cleaning.

**NOTICE** – Do not overtighten liner lock allen screw.

6 Top Cover

7 Set Screw (Inlet Guide)

8 Inlet Guide

Remove inlet guide. From power pin end, blow air through liner and stainless tube until free of debris.

Reinstall inlet guide.

### 7-3. Troubleshooting Table

					 <b>Disconnect power before troubleshooting.</b>
---	---	---	---	---	---

Trouble	Remedy
No wire feed at gun, feeder not operating. Check motor or brake solenoid.	Reset circuit breaker in feeder/control box. See feeder/control owner's manual.
	Replace trigger-switch and test operation.
	Check trigger-switch wires for continuity.
No wire feed at gun, feeder operating properly.	Reset circuit breaker in feeder/control box and check for short in motor leads. See feeder/control owner's manual.
	Check potentiometer with meter and replace if necessary.
	Check motor and potentiometer wires for continuity.
	See feeder/control owner's manual.
Wire feeds, but welding wire is not energized.	Clean and tighten all power connections.
	See feeder/control owner's manual.
	Check operation of welding power source.
Wire feeds erratically.	Check conduit for wear and obstruction and replace if necessary.
	Check contact tip for correct size and replace if necessary.
	Check pressure roll tension setting (see Section 6-2).
	Check for proper head tube liner (see Table 9-7).
Wire feeds one speed only.	Check potentiometer with meter and replace if necessary.
	Check continuity of welding gun wire feed speed potentiometer and replace if necessary.
	See feeder/control owner's manual.
Pressing gun trigger does not energize feeder. Welding wire is not energized. Shielding gas does not flow.	Secure plug from gun control cable into gun control receptacle on feeder.
	Have nearest Factory Authorized Service Agent check optional water flow switch, if applicable.
Wire feeds, shielding gas flows, but welding wire is not energized.	See Troubleshooting section in welding power source manual.
Arc varies and welding wire is kinked when feeding out gun.	Place Motor Torque switch in low torque position if welding with .030 (0.8 mm) aluminum welding wire on an XR control box.

# SECTION 8 – ELECTRICAL DIAGRAMS

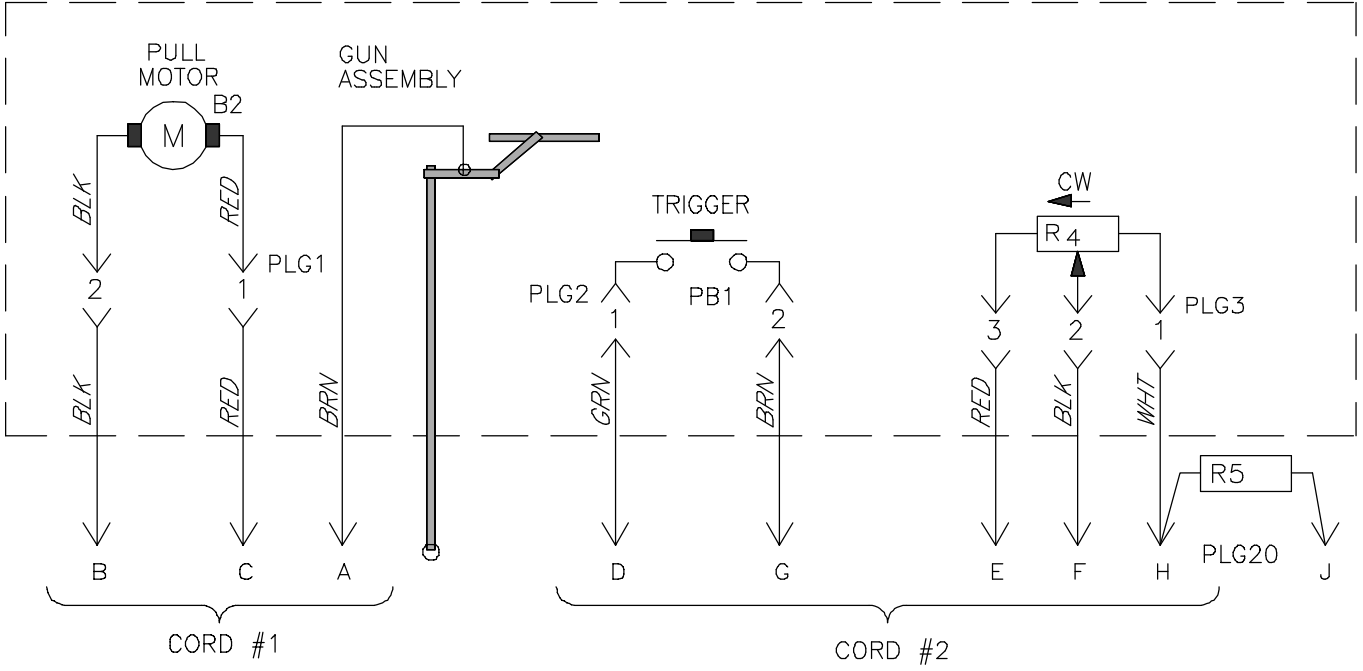

<b>⚠ WARNING</b>	<ul style="list-style-type: none"> <li>Do not touch live electrical parts.</li> <li>Disconnect input power or stop engine before servicing.</li> <li>Do not operate with covers removed.</li> <li>Have only qualified persons install, use, or service this unit.</li> </ul>
<b>ELECTRIC SHOCK HAZARD</b>	

228 669-B

Figure 8-1. Circuit Diagram For XR-AlumaPro Gun

## Notes

---



---



---



---



---



---



---



---



---



---



---



---



---



---



---



---



---



---



---



---



---



---



---

# SECTION 9 – PARTS LIST

 Hardware is common and not available unless listed.

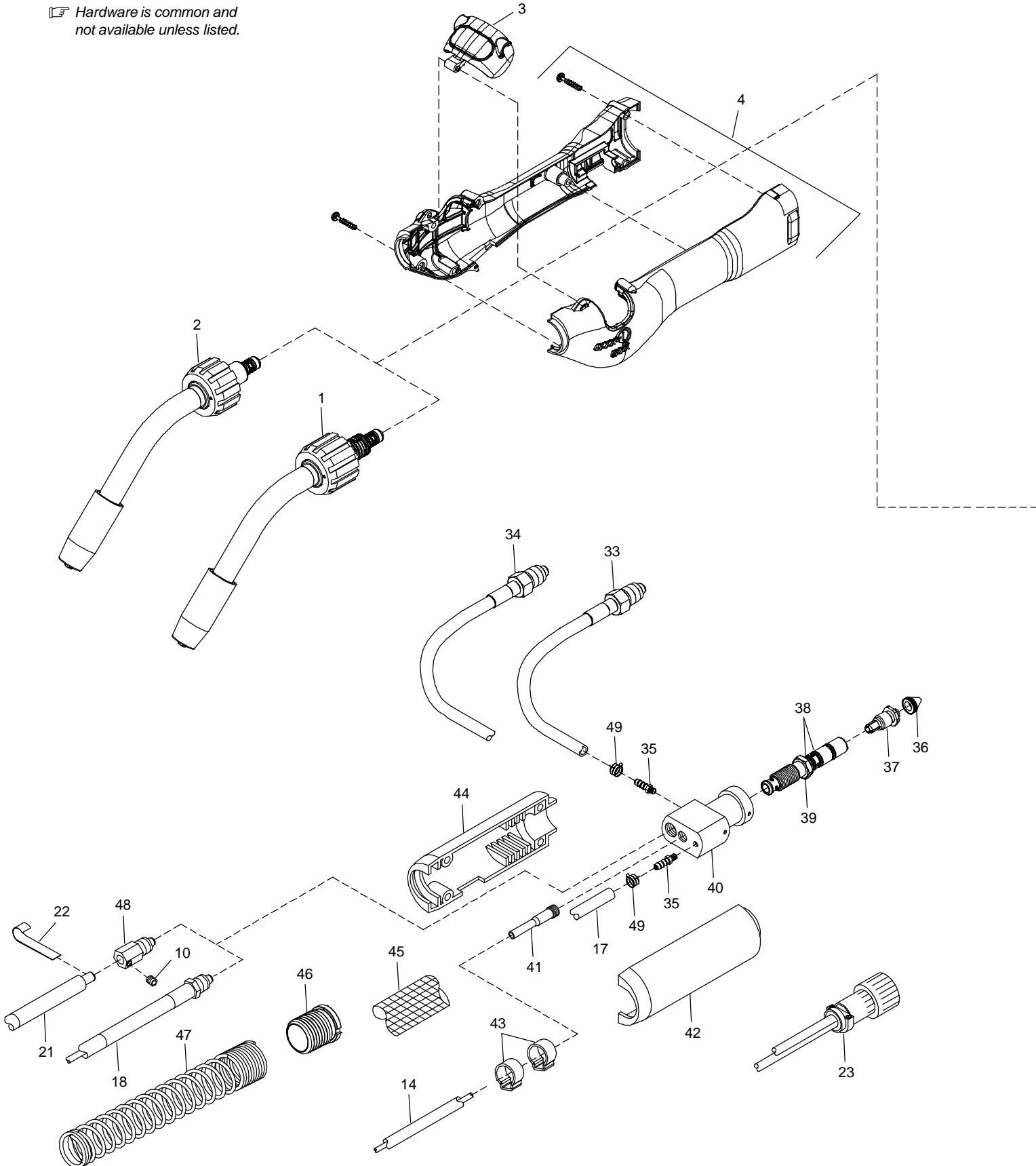
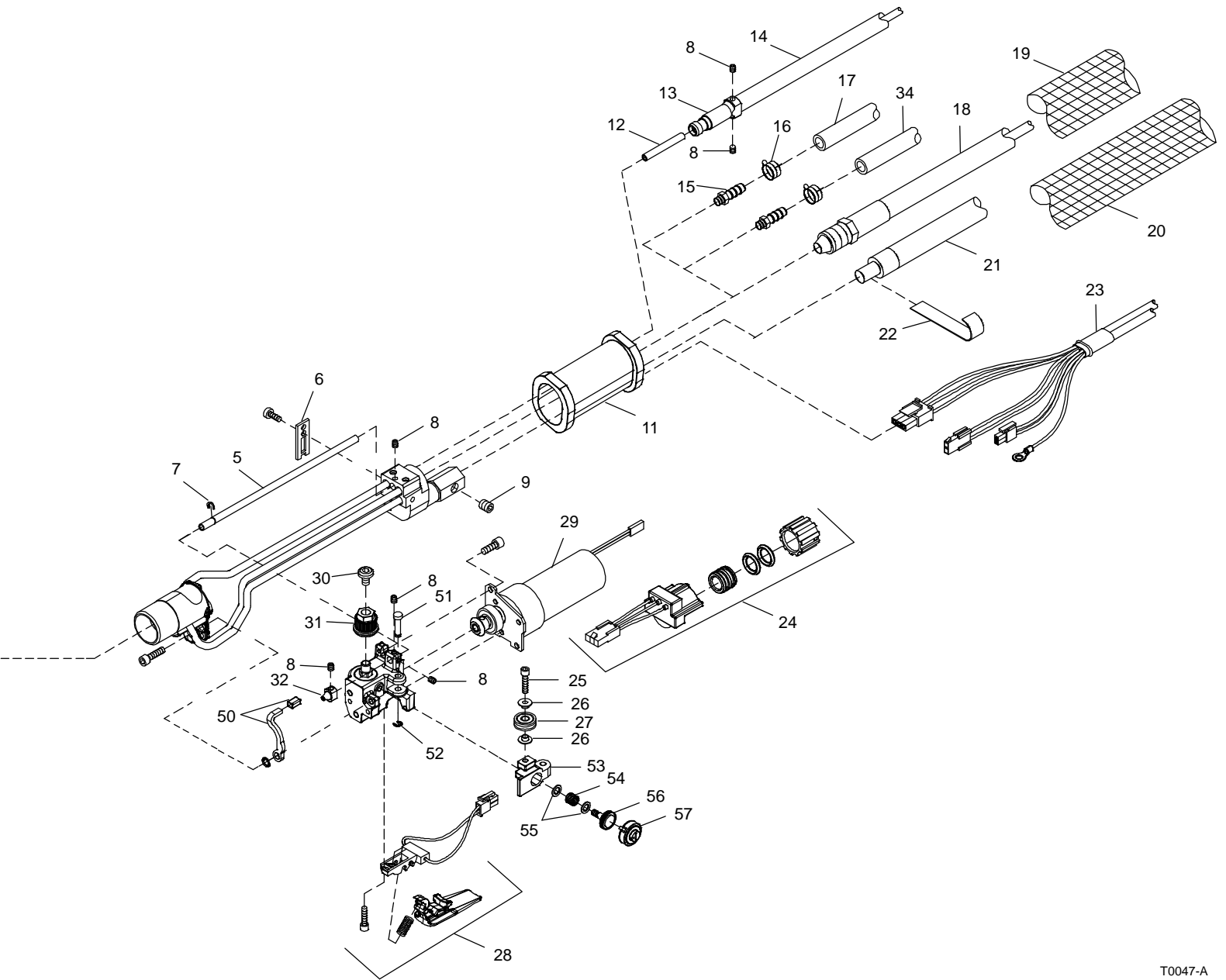

Figure 9-1. Exploded View Of XR-A AlumaPro Gun





T0047-A

Item No.	Part No.	Description	Quantity
----------	----------	-------------	----------

**Figure 9-1. Exploded View Of XR-A AlumaPro Gun**

1	231 517	Kit, Head Tube Assy (Water) Long	1
2	231 519	Kit, Head Tube Assy (Air) Short	1
2	231 518	Kit, Head Tube Assy (Air) Long	1
3	227 403	Cover, W/Spring Plunger (Includes)	1
	187 316	Label, Pinch Wordless	1
4	227 404	Handle Assembly, Left/Right	1
5	227 407	Tube, Liner Stainless	1
6	227 406	Strain Relief, Cable Control	1
7	M1476	Clip, C, Retaining 0.1875 Dia Shaft	1
8	135 126	Screw, Set # 6-32x .12 Cup Pt Sch Stl Pln	6
9	M1500	Screw, Set 312-18X .31 Conept Sch Stl Pln Nylok	1
10	141 694	Screw, Set 312-18x .37 Conept Sch Stl Pln	1
11	189 081	Strain Relief	1
12	229 887	Liner, Replacement 15 Ft	1
12	229 891	Liner, Replacement 25 Ft	1
12	232 321	Liner, Replacement 35 Ft	1

Item No.	Part No.	Description	Quantity
----------	----------	-------------	----------

**Figure 9-1. Exploded View Of XR-A AlumaPro Gun (Continued)**

13	227 608	Reducer, Guide Liner	1
14	252 652	Kit, Conduit Monocoil 15 Ft	1
14	252 689	Kit, Conduit Monocoil 25 Ft	1
14	252 690	Kit, Conduit Monocoil 35 Ft	1
15	144 172	Ftg, Hose Brs Barbed M 3/16 Tbg X .250-20 (Air)	2
15	135 580	Ftg, Gas (Water)	2
16	237 864	Clamp, Hose .375 - .450 Clp Dia Slftng Green W/Shortened Middle Tab	2
17	134 834	Hose, Sae .187 Id X .410 Od Xcoil	Order by Feet
18	191 052	Cable, Power/Water Out 15 Ft	1
18	228 696	Cable, Power/Water Out 25 Ft	1
18	232 055	Cable, Power/Water Out 35 Ft	1
19	234 416	Cable Cover Assy, Leather W/Velcro 17 in.	1
20	234 109	Kit, Cable Cover Leather W/Velcro 15 Ft	1
20	234 110	Kit, Cable Cover Leather W/Velcro 25 Ft	1
20	234 111	Kit, Cable Cover Leather W/Velcro 35 Ft	1
21	M1531	Cable, Power 15 Ft (Air)	1
21	M1532	Cable, Power 25 Ft (Air)	1
21	M1533	Cable, Power 35 Ft (Air)	1
22	235 225	Strip, Cop .010 X 1.500 X .750	2
23	227 757	Cable, Control 15 Ft (Water)	1
23	227 446	Cable, Control 25 Ft (Water)	1
23	231 888	Cable, Control 35 Ft (Water)	1
23	236 836	Cable, Control 15 Ft (Air)	1
23	236 837	Cable, Control 25 Ft (Air)	1
23	236 838	Cable, Control 35 Ft (Air)	1
24	227 452	Potentiometer Assy	1
25	231 443	Screw, 006-32x .44 Soc Hd-Hex Gr8 Pld Lkg Patch	1
26	134 624	Washer, Shldr.140id 0.187odx.094t .375odx.031t Nyl	2
27	227 439	Drive Roll Assy, Idler .645 Od	1
28	245 081	Trigger Assy	1
29	234 782	Drive Motor Assy, Replacement	1
	++232 483	Drive Assy, Replacement Water	1
	++232 484	Drive Assy, Replacement Air	1
30	226 588	Screw, 010-32x .37 Btn Hd-Soc Sst Lkg Patch	1
31	227 434	Drive Roll, Knurled	1
32	227 408	Guide, Inlet	1
33	196 177	Hose, Water Out 10 in.	1
34	191 072	Hose, Water In 15 Ft	1
34	229 892	Hose, Water In 25 Ft	1
34	232 056	Hose, Water In 35 Ft	1
35	202 513	Ftg, Hose Brs Barbed M 3/16 Tbg X .250-20 (Water)	2
35	202 513	Ftg, Hose Brs Barbed M 3/16 Tbg X .250-20 (Air)	2
36	229 853	Guide, Cone Outlet Nylon	1
37	229 852	Guide, Collet Outlet .030-1/16	1
38	079 974	O-Ring, .500 Id X .103 Cs Rbr	2
39	193 896	Pin, Power Assembly	1
40	187 029	Connector, Power/Gas	1
41	203 539	Fitting, Liner Double Wound Adapter	1
42	189 811	Housing, Power Pin Lh	1
43	149 332	Clamp, Hose .405 - .485 Clp Dia Slftng Olive Dra	2
44	189 812	Housing, Power Pin Rh	1
45	227 449	Jacket, Cable 3 Ft 4 in. (Power Pin)	1
46	203 560	Strain Relief, Spring Retainer	1
47	203 562	Spring, Strain Relief	1
48	M1501	Ftg, Connection Power Weld	1
49	089 120	Clamp, Hose .375 - .450 Clp Dia Slftng Green	2
50	227 405	Lever, Pressure Arm	1
51	227 420	Pin, Pressure Arm	1
52	191 088	Ring, Rtnng Ext .125 Shaft X .015 Thk E Style	1

Item No.	Part No.	Description	Quantity
----------	----------	-------------	----------

**Figure 9-1. Exploded View Of XR-A AlumaPro Gun (Continued)**

... 53	227 435	.. Arm, Pressure (Machined)	1
... 54	227 421	.. Spring, Cprsn .360 Od X .059 Wire X .440 Free	1
... 55	229 850	.. Washer, Pressure Arm Precision	2
... 56	229 849	.. Shaft, Pressure Arm Brs	1
... 57	229 851	.. Nut, Pressure Arm Plastic	1

++ Drive assemblies include drive housing, pressure arm, pressure arm pin, pressure arm lever, power block assy, drive shaft assy, pressure arm shaft, tube liner, O-ring, set screws, and springs.

**To maintain the factory original performance of your equipment, use only Manufacturer's Suggested Replacement Parts. Model and serial number required when ordering parts from your local distributor.**

 Hardware is common and not available unless listed.

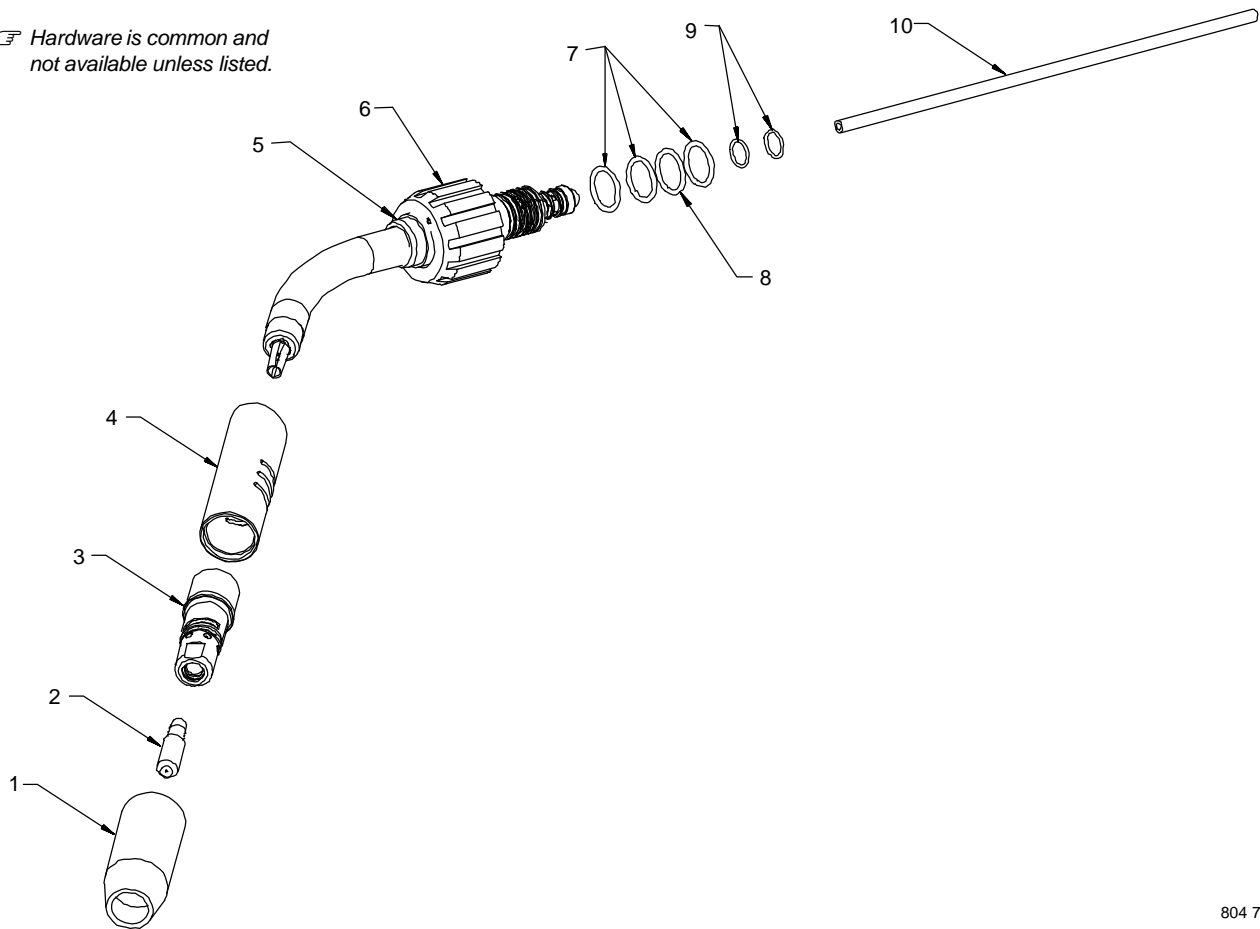

804 706-A

**Figure 9-2. (Water) Head Tube Assembly Of AlumaPro Gun**

Item No.	Part No.	Description	Quantity
----------	----------	-------------	----------

**Figure 9-2. (Water) Head Tube Assembly Of AlumaPro Gun (Figure 9-1 Item 1**

...	231 517	.. Kit, Head Tube Assy Water AlumaPro (Long) (Includes)	1
... 1	199 618	... Nozzle, Copper 5/8 in. Orifice Tapered Heavy Duty	1
... 2	206 189	... Tip, Fastip .312 Od .052 And 3/64al Wires	1
... 3	229 670	... Diffuser, .281/.312 Od Fastip 1/8 Tip Rec AlumaPro	1
... 4	230 420	... Insulator, Outer Water Long Fastip	1
... 5	227 416	... Insulator, Ring Inner Rear	1
... 6	229 889	... Nut, Headtube Rotation Water	1
...	230 970	.. Kit, Replacement O-Rings Head Tube Water (Includes)	1
... 7	194 261	... O-Ring, .551 Id X .070 Cs 70 Duro Buna-n	3
... 8	210 771	... O-Ring, 14.99mm Id X 1.27mm Cs 70 Duro Buna-n	1
... 9	191 191	... O-Ring, .312 Id X .070 Cs 70 Duro Buna-n	2
... 10	229 431	... Liner, Teflon .047-.062 Wire X 8.250 (Fastip)	1

To maintain the factory original performance of your equipment, use only Manufacturer's Suggested Replacement Parts. Model and serial number required when ordering parts from your local distributor.

 Hardware is common and not available unless listed.

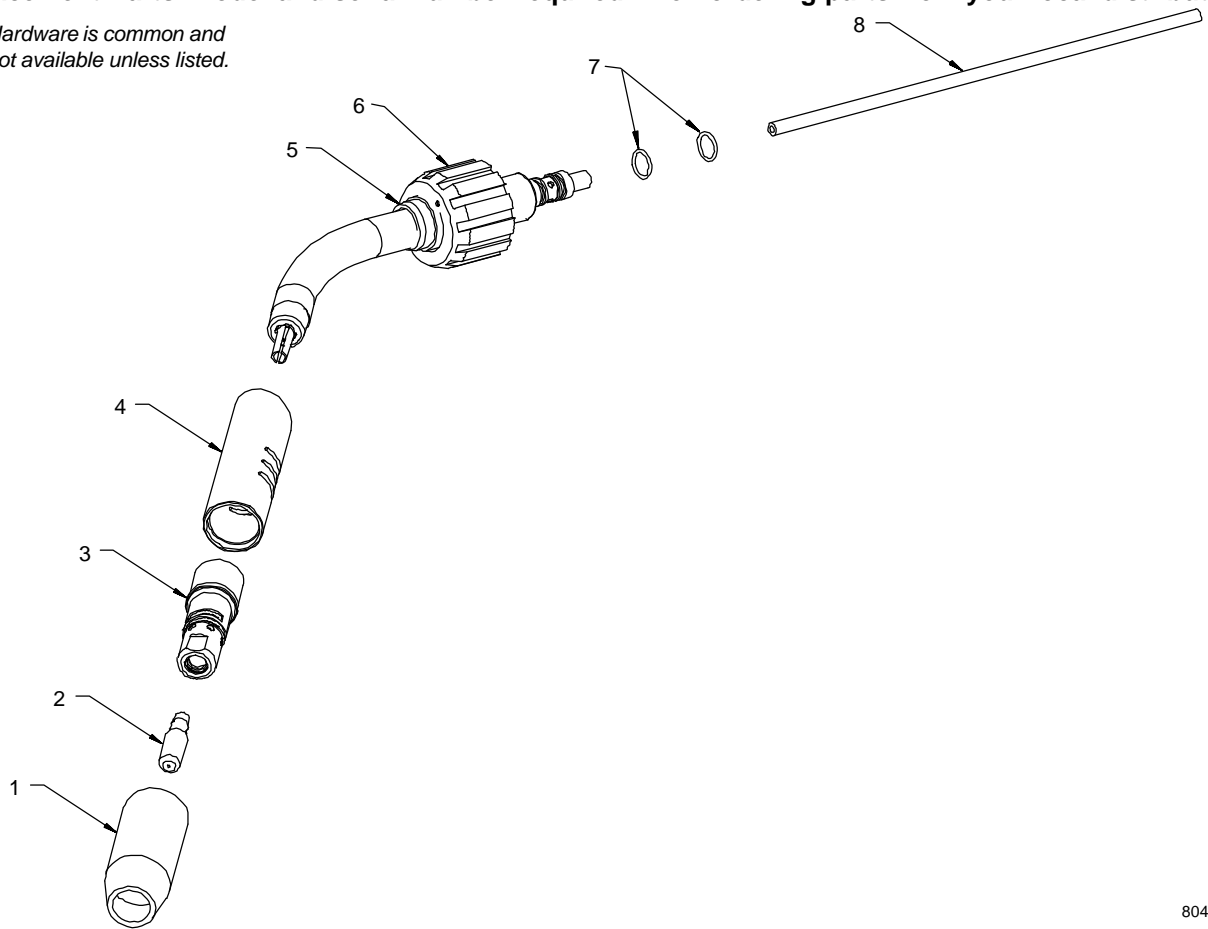

804 705-A

**Figure 9-3. (Air) Head Tube Assembly Of AlumaPro Gun**

Item No.	Part No.	Description	Quantity
<b>Figure 9-3. (Air) Head Tube Assembly Of AlumaPro Gun (Figure 9-1 Item 2)</b>			
.....	231 518	.. Kit, Head Tube Assy Air (Long) (Includes)	1
.....	231 519	.. Kit, Head Tube Assy Air (Short) (Includes)	1
... 1	198 855	... Nozzle, Copper 5/8 in. Orifice Tapered	1
... 2	206 189	... Tip, Fastip .312 Od .052 And 3/64al Wires	1
... 3	229 670	... Diffuser, .281/.312 Od Fastip 1/8 Tip Rec AlumaPro	1
... 4	229 673	... Insulator, Outer Air (Long)	1
... 4	227 159	... Insulator, Outer Air (Short)	1
... 5	227 416	... Insulator, Ring Inner Rear	1
... 6	227 168	... Nut, Headtube Rotation	1
.....	230 969	.. Kit, Replacement O-Rings Head Tube Air (Includes)	1
... 7	191 191	... O-Ring, .312 Id X .070 Cs 70 Duro Buna-n	2
... 8	229 431	... Liner, Teflon .047-.062 Wire X Long (Fastip)	1
... 8	230 239	... Liner, Teflon .047-.062 Wire X Short (Fastip)	1

To maintain the factory original performance of your equipment, use only Manufacturer's Suggested Replacement Parts. Model and serial number required when ordering parts from your local distributor.

# SECTION 10 – PARTS LIST INCLUDING CONSUMABLES

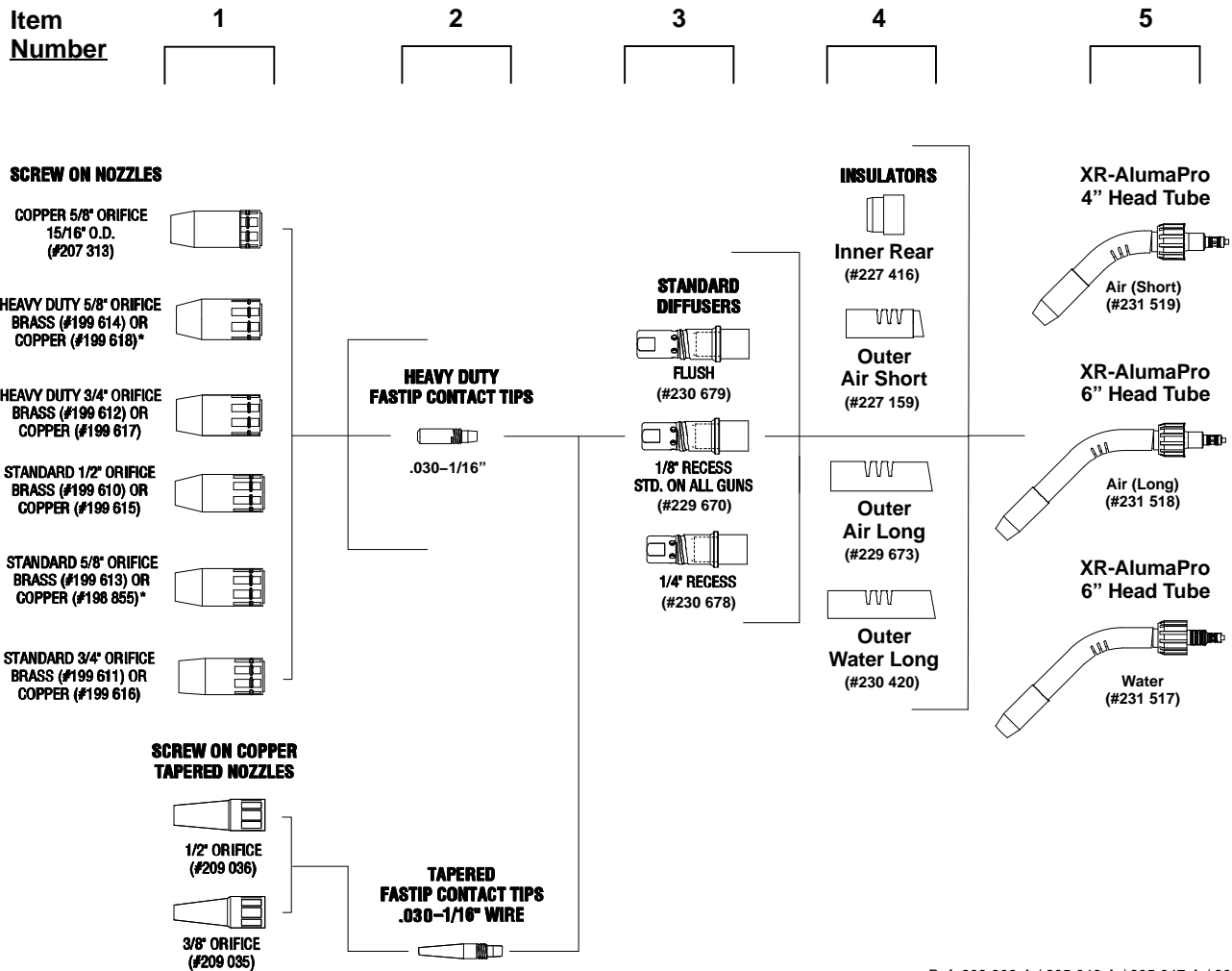

Ref. 803 909-A / 805 046-A / 805 047-A / 805 048-A

Figure 10-1. Consumables Flowchart

Item No.	Part No.	Description	Quantity
----------	----------	-------------	----------

## 10-1. Consumables Flowchart

Table 10-1. Nozzles

...	1	◆199 610	.. Nozzle, Screw On Brass 1/2 in. Orifice	1
...	1	◆199 611	.. Nozzle, Screw On Brass 3/4 in. Orifice Straight	1
...	1	◆199 612	.. Nozzle, Screw On Brass 3/4 in. Orifice Straight Heavy Duty	1
...	1	◆199 613	.. Nozzle, Screw On Brass 5/8 in. Orifice	1
...	1	◆199 614	.. Nozzle, Screw On Brass 5/8 in. Orifice Heavy Duty	1
...	1	◆199 615	.. Nozzle, Screw On Copper 1/2 in. Orifice	1
...	1	◆199 616	.. Nozzle, Screw On Copper 3/4 in. Orifice	1
...	1	◆199 617	.. Nozzle, Screw On Copper 3/4 in. Orifice Heavy Duty	1
...	1	198 855	.. Nozzle, Screw On Copper 5/8 in. Orifice	1
...	1	199 618	.. Nozzle, Screw On Copper 5/8 in. Orifice Heavy Duty	1
...	1	◆207 313	.. Nozzle, Screw On Copper 5/8 in. Orifice 15/16 OD	1
...	1	◆209 035	.. Nozzle, Screw On Copper 3/8 in. Orifice Tapered (Requires Diffuser 229 670, 230 678, 230 679 Used With Any Tapered FasTip™ Contact Tip)	1
...	1	◆209 036	.. Nozzle, Screw On Copper 1/2 in. Orifice Tapered (Requires Diffuser 229 670, 230 678, 230 679 Used With Any Tapered FasTip™ Contact Tip)	1

**Table 10-2. Heavy Duty FasTip™ Contact Tips\***

... 2	◆206 185	.. .030 in. (0.8 mm)	1
... 2	◆206 186	.. .035 in. (0.9 mm)	1
... 2	206 187	.. .040 in. (1.0 mm) or .035 in. (0.9 mm) Aluminum Wire	1
... 2	◆206 188	.. .045 in. (1.2 mm)	1
... 2	206 189	.. .052 in. (1.3 mm) or 3/64 in. (1.2 mm) Aluminum Wire	1
... 2	◆206 190	.. 1/16 in. (1.6 mm)	1
... 2	◆206 191	.. .068 in. (1.7 mm) or 1/16 in. (1.6 mm) Aluminum Wire	1

**Table 10-3. Tapered FasTip™ Contact Tips\***

... 2	◆209025	.. .030 in. (0.8 mm)	1
... 2	◆209026	.. .035 in. (0.9 mm)	1
... 2	◆209027	.. .045 in. (1.2 mm)	1
... 2	◆209028	.. 3/64 in. (1.2 mm)	1
... 2	◆209029	.. .052 in. (1.3 mm)	1
... 2	◆209030	.. 1/16 in. (1.6 mm)	1

**Table 10-4. Gas Diffusers**

... 3	229 670	.. 1/8 in. Tip Recess – For Heavy Duty FasTip Contact Tips (Standard On All Guns)	1
... 3	◆230 678	.. 1/4 in. Tip Recess – For Heavy Duty FasTip Contact Tips	1
... 3	◆230 679	.. Flush Tip – For Heavy Duty FasTip Contact Tips	1

**Table 10-5. Insulators**

... 4	227 416	.. Insulator, Ring Inner Rear	1
... 4	227 159	.. Insulator, Outer Air Short (4 in.)	1
... 4	229 673	.. Insulator, Outer Air Long (6 in.)	1
... 4	230 420	.. Insulator, Outer Water Long FasTip (6 in.)	1

**Table 10-6. Head Tube Assemblies**

... 5	231 517	.. Kit, Head Tube Assy Water (Long)	1
... 5	231 518	.. Kit, Head Tube Assy Air (Long)	1
... 5	231 519	.. Kit, Head Tube Assy Air (Short)	1

**Table 10-7. FasTip Head Tube Liners (Not Shown)**

...	229 674	.. Liner, Teflon .030–.035 Wire X Long (Fastip)	1
...	227 161	.. Liner, Teflon .030–.035 Wire X Short (Fastip)	1
...	229 431	.. Liner, Teflon .047–.062 Wire X Long (Fastip)	1
...	230 239	.. Liner, Teflon .047–.062 Wire X Short (Fastip)	1
...	233 998	.. Liner, Phos Bronze .030–1/16 Wire (Short Aluma–Pro)	1
...	233 999	.. Liner, Phos Bronze .030–1/16 Wire (Long Aluma–Pro)	1

**Table 10-8. Wire Kit (Not Shown)**

...	◆230 708	.. Kit, Idler Roll 1/16 (.062)	1
...	◆198 377	.. Hardwire Liner Kit, 30W For Steel&Stainless	1

◆OPTIONAL

\*All contact tips are packaged in bags of 25.

BE SURE TO PROVIDE MODEL WHEN ORDERING REPLACEMENT PARTS.

**To maintain the factory original performance of your equipment, use only Manufacturer's Suggested Replacement Parts. Model is required when ordering parts from your local distributor.**

# TRUE BLUE<sup>®</sup>

## WARRANTY

Effective January 1, 2015

(Equipment with a serial number preface of MF or newer)

This limited warranty supersedes all previous Miller warranties and is exclusive with no other guarantees or warranties expressed or implied.

### Warranty Questions?

Call  
1-800-4-A-MILLER  
for your local  
Miller distributor.

Your distributor also gives you ...

### Service

You always get the fast, reliable response you need. Most replacement parts can be in your hands in 24 hours.

### Support

Need fast answers to the tough welding questions? Contact your distributor. The expertise of the distributor and Miller is there to help you, every step of the way.

LIMITED WARRANTY – Subject to the terms and conditions below, Miller Electric Mfg. Co., Appleton, Wisconsin, warrants to its original retail purchaser that new Miller equipment sold after the effective date of this limited warranty is free of defects in material and workmanship at the time it is shipped by Miller. THIS WARRANTY IS EXPRESSLY IN LIEU OF ALL OTHER WARRANTIES, EXPRESS OR IMPLIED, INCLUDING THE WARRANTIES OF MERCHANTABILITY AND FITNESS.

Within the warranty periods listed below, Miller will repair or replace any warranted parts or components that fail due to such defects in material or workmanship. Miller must be notified in writing within thirty (30) days of such defect or failure, at which time Miller will provide instructions on the warranty claim procedures to be followed. If notification is submitted as an online warranty claim, the claim must include a detailed description of the fault and the troubleshooting steps taken to identify failed components and the cause of their failure.

Miller shall honor warranty claims on warranted equipment listed below in the event of such a failure within the warranty time periods. All warranty time periods start on the delivery date of the equipment to the original end-user purchaser, and not to exceed twelve months after the equipment is shipped to a North American distributor or eighteen months after the equipment is shipped to an International distributor.

1. 5 Years Parts — 3 Years Labor
  - \* Original Main Power Rectifiers Only to Include SCRs, Diodes, and Discrete Rectifier Modules
2. 3 Years — Parts and Labor
  - \* Auto-Darkening Helmet Lenses (Except Classic Series) (No Labor)
  - \* Engine Driven Welder/Generators  
**(NOTE: Engines are Warranted Separately by the Engine Manufacturer.)**
  - \* Inverter Power Sources (Unless Otherwise Stated)
  - \* Plasma Arc Cutting Power Sources
  - \* Process Controllers
  - \* Semi-Automatic and Automatic Wire Feeders
  - \* Transformer/Rectifier Power Sources
3. 2 Years — Parts and Labor
  - \* Auto-Darkening Helmet Lenses – Classic Series Only (No Labor)
  - \* Fume Extractors – Capture 5, Filtair 400 and Industrial Collector Series
4. 1 Year — Parts and Labor Unless Specified
  - \* Automatic Motion Devices
  - \* CoolBelt and CoolBand Blower Unit (No Labor)
  - \* Desiccant Air Dryer System
  - \* External Monitoring Equipment and Sensors
  - \* Field Options  
**(NOTE: Field options are covered for the remaining warranty period of the product they are installed in, or for a minimum of one year — whichever is greater.)**
  - \* RFCS Foot Controls (Except RFCS-RJ45)
  - \* Fume Extractors – Filtair 130, MWX and SWX Series HF Units
  - \* ICE/XT Plasma Cutting Torches (No Labor)
  - \* Induction Heating Power Sources, Coolers  
**(NOTE: Digital Recorders are Warranted Separately by the Manufacturer.)**
  - \* LiveArc Welding Performance Management System
  - \* Load Banks
  - \* Motor-Driven Guns (except Spoolmate Spoolguns)
  - \* PAPR Blower Unit (No Labor)
  - \* Positioners and Controllers
  - \* Racks
  - \* Running Gear/Trailers
  - \* Spot Welders
  - \* Subarc Wire Drive Assemblies
  - \* Water Coolant Systems
  - \* TIG Torches (No Labor)
  - \* Wireless Remote Foot/Hand Controls and Receivers
  - \* Work Stations/Weld Tables (No Labor)

5. 6 Months — Parts
  - \* Batteries
  - \* Bernard Guns (No Labor)
  - \* Tregaskiss Guns (No Labor)
6. 90 Days — Parts
  - \* Accessory (Kits)
  - \* Canvas Covers
  - \* Induction Heating Coils and Blankets, Cables, and Non-Electronic Controls
  - \* M-Guns
  - \* MIG Guns and Subarc (SAW) Torches
  - \* Remote Controls and RFCS-RJ45
  - \* Replacement Parts (No labor)
  - \* Roughneck Guns
  - \* Spoolmate Spoolguns

Miller's True Blue<sup>®</sup> Limited Warranty shall not apply to:

1. **Consumable components; such as contact tips, cutting nozzles, contactors, brushes, relays, work station table tops and welding curtains, or parts that fail due to normal wear. (Exception: brushes and relays are covered on all engine-driven products.)**
2. Items furnished by Miller, but manufactured by others, such as engines or trade accessories. These items are covered by the manufacturer's warranty, if any.
3. Equipment that has been modified by any party other than Miller, or equipment that has been improperly installed, improperly operated or misused based upon industry standards, or equipment which has not had reasonable and necessary maintenance, or equipment which has been used for operation outside of the specifications for the equipment.

MILLER PRODUCTS ARE INTENDED FOR PURCHASE AND USE BY COMMERCIAL/INDUSTRIAL USERS AND PERSONS TRAINED AND EXPERIENCED IN THE USE AND MAINTENANCE OF WELDING EQUIPMENT.

In the event of a warranty claim covered by this warranty, the exclusive remedies shall be, at Miller's option: (1) repair; or (2) replacement; or, where authorized in writing by Miller in appropriate cases, (3) the reasonable cost of repair or replacement at an authorized Miller service station; or (4) payment of or credit for the purchase price (less reasonable depreciation based upon actual use) upon return of the goods at customer's risk and expense. Miller's option of repair or replacement will be F.O.B., Factory at Appleton, Wisconsin, or F.O.B. at a Miller authorized service facility as determined by Miller. Therefore no compensation or reimbursement for transportation costs of any kind will be allowed.

TO THE EXTENT PERMITTED BY LAW, THE REMEDIES PROVIDED HEREIN ARE THE SOLE AND EXCLUSIVE REMEDIES. IN NO EVENT SHALL MILLER BE LIABLE FOR DIRECT, INDIRECT, SPECIAL, INCIDENTAL OR CONSEQUENTIAL DAMAGES (INCLUDING LOSS OF PROFIT), WHETHER BASED ON CONTRACT, TORT OR ANY OTHER LEGAL THEORY.

ANY EXPRESS WARRANTY NOT PROVIDED HEREIN AND ANY IMPLIED WARRANTY, GUARANTY OR REPRESENTATION AS TO PERFORMANCE, AND ANY REMEDY FOR BREACH OF CONTRACT TORT OR ANY OTHER LEGAL THEORY WHICH, BUT FOR THIS PROVISION, MIGHT ARISE BY IMPLICATION, OPERATION OF LAW, CUSTOM OF TRADE OR COURSE OF DEALING, INCLUDING ANY IMPLIED WARRANTY OF MERCHANTABILITY OR FITNESS FOR PARTICULAR PURPOSE, WITH RESPECT TO ANY AND ALL EQUIPMENT FURNISHED BY MILLER IS EXCLUDED AND DISCLAIMED BY MILLER.

Some states in the U.S.A. do not allow limitations of how long an implied warranty lasts, or the exclusion of incidental, indirect, special or consequential damages, so the above limitation or exclusion may not apply to you. This warranty provides specific legal rights, and other rights may be available, but may vary from state to state.

In Canada, legislation in some provinces provides for certain additional warranties or remedies other than as stated herein, and to the extent that they may not be waived, the limitations and exclusions set out above may not apply. This Limited Warranty provides specific legal rights, and other rights may be available, but may vary from province to province.





# Owner's Record

Please complete and retain with your personal records.

Model Name

Serial/Style Number

Purchase Date

(Date which equipment was delivered to original customer.)

Distributor

Address

City

State

Zip



## For Service

Contact a **DISTRIBUTOR** or **SERVICE AGENCY** near you.

Always provide Model Name and Serial/Style Number.

Contact your Distributor for:

Welding Supplies and Consumables

Options and Accessories

Personal Safety Equipment

Service and Repair

Replacement Parts

Training (Schools, Videos, Books)

Technical Manuals (Servicing Information and Parts)

Circuit Diagrams

Welding Process Handbooks

To locate a Distributor or Service Agency visit [www.millerwelds.com](http://www.millerwelds.com) or call 1-800-4-A-Miller

Contact the Delivering Carrier to:

File a claim for loss or damage during shipment.

For assistance in filing or settling claims, contact your distributor and/or equipment manufacturer's Transportation Department.

### Miller Electric Mfg. Co.

An Illinois Tool Works Company  
1635 West Spencer Street  
Appleton, WI 54914 USA

### International Headquarters—USA

USA Phone: 920-735-4505 Auto-Attended  
USA & Canada FAX: 920-735-4134  
International FAX: 920-735-4125

For International Locations Visit  
[www.MillerWelds.com](http://www.MillerWelds.com)

