



OM-1594

181 715L

July 2002

Processes



MIG (GMAW) Welding

Description



Wire Feeder And Feeder Gun



XRTM Control

XRTM Air- And Water-Cooled Guns

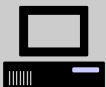
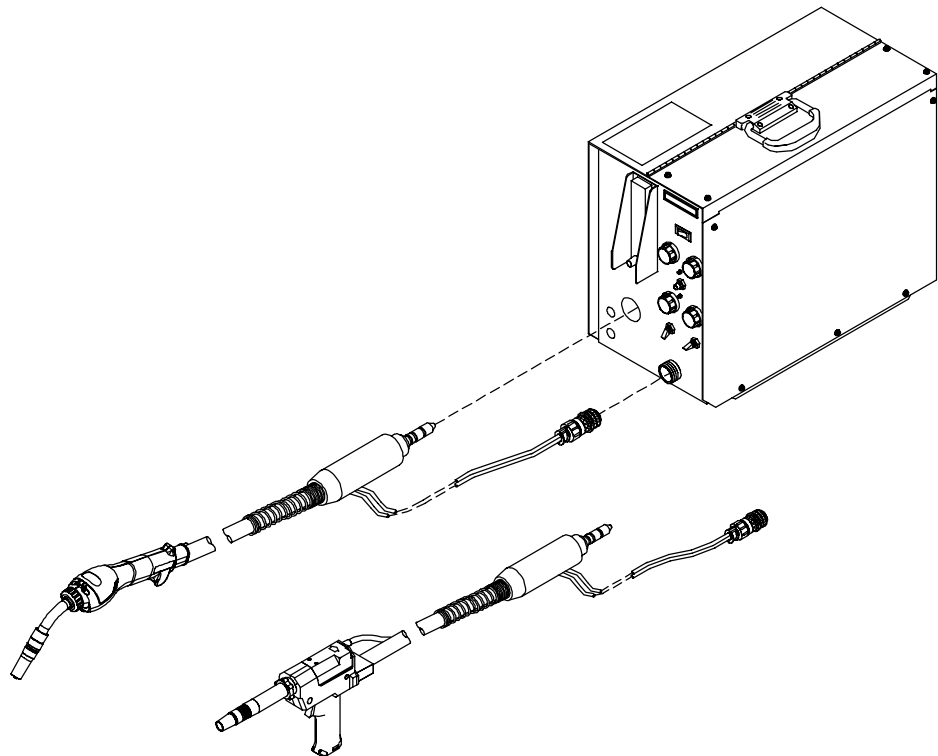

Visit our website at
www.MillerWelds.com

OWNER'S MANUAL

From Miller to You

Thank you and congratulations on choosing Miller. Now you can get the job done and get it done right. We know you don't have time to do it any other way.

That's why when Niels Miller first started building arc welders in 1929, he made sure his products offered long-lasting value and superior quality. Like you, his customers couldn't afford anything less. Miller products had to be more than the best they could be. They had to be the best you could buy.

Today, the people that build and sell Miller products continue the tradition. They're just as committed to providing equipment and service that meets the high standards of quality and value established in 1929.

This Owner's Manual is designed to help you get the most out of your Miller products. Please take time to read the Safety precautions. They will help you protect yourself against potential hazards on the worksite.

We've made installation and operation quick and easy. With Miller you can count on years of reliable service with proper maintenance. And if for some reason the unit needs repair, there's a Troubleshooting section that will help you figure out what the problem is. The parts list will then help you to decide the exact part you may need to fix the problem. Warranty and service information for your particular model are also provided.



Miller is the first welding equipment manufacturer in the U.S.A. to be registered to the ISO 9001 Quality System Standard.

Miller Electric manufactures a full line of welders and welding related equipment. For information on other quality Miller products, contact your local Miller distributor to receive the latest full line catalog or individual catalog sheets. **To locate your nearest distributor or service agency call 1-800-4-A-Miller, or visit us at www.MillerWelds.com on the web.**



Working as hard as you do – every power source from Miller is backed by the most hassle-free warranty in the business.

Miller offers a Technical Manual which provides more detailed service and parts information for your unit. To obtain a Technical Manual, contact your local distributor. Your distributor can also supply you with Welding Process Manuals such as SMAW, GTAW, GMAW, and GMAW-P.



TABLE OF CONTENTS

WARNING

This product, when used for welding or cutting, produces fumes or gases which contain chemicals known to the State of California to cause birth defects and, in some cases, cancer. (California Health & Safety Code Section 25249.5 et seq.)

SECTION 1 – SAFETY PRECAUTIONS - READ BEFORE USING	1
1-1. Symbol Usage	1
1-2. Arc Welding Hazards	1
1-3. Additional Symbols For Installation, Operation, And Maintenance	3
1-4. Principal Safety Standards	3
1-5. EMF Information	4
SECTION 1 – CONSIGNES DE SECURITE – LIRE AVANT UTILISATION	5
1-1. Signification des symboles	5
1-2. Dangers relatifs au soudage à l'arc	5
1-3. Dangers supplémentaires en relation avec l'installation, le fonctionnement et la maintenance	7
1-4. Principales normes de sécurité	8
1-5. Information sur les champs électromagnétiques	8
SECTION 2 – DEFINITIONS	9
2-1. Warning Label Definitions	9
2-2. Rating Label For CE Products	10
2-3. Symbols And Definitions	11
SECTION 3 – INTRODUCTION	11
3-1. Specifications	11
3-2. Duty Cycle And Overheating	12
SECTION 4 – INSTALLATION	13
4-1. Connections With A Constant Current (CC), Constant Voltage (CV) Or Constant Current/ Constant Voltage (CC/CV) Welding Power Source Having A 14-Socket Receptacle	13
4-2. Air-Cooled Feeder Connections	14
4-3. Air-Cooled Gun Connections	15
4-4. Water-Cooled Feeder Connections	16
4-5. Water-Cooled Gun Connections	17
4-6. 14-Pin Plug Information	18
4-7. Voltage Sensing Lead Connections	18
4-8. Optional Meter Circuit Board Settings	19
4-9. Adjusting Contact Tip Position	20
4-10. Opening Top Cover Of XR-Edge Gun	20
4-11. Removing Top Cover Of Pistol Grip Gun	21
4-12. Installing Wire Spool	21
4-13. Threading Welding Wire Through Feeder	22
4-14. Threading Welding Wire Through Gun	23
4-15. Adjusting Wire Feed Starting Speed	24
4-16. Setting Switches For Preflow And Postflow	25
4-17. Adjusting Trigger Hold Actuation Time	26
SECTION 5 – OPERATION	27
5-1. Controls	27
5-2. Internal Controls	28
5-3. Gun Controls	29
5-4. Shielding Gas	29
5-5. Coolant Supply For Water-Cooled Models Only	29
5-6. Sequence Of Gas Metal Arc Welding (GMAW) – Continuous Or Spot	30
SECTION 6 – MAINTENANCE & TROUBLESHOOTING	30
6-1. Feeder Drive Assembly Maintenance	31
6-2. Gun Drive Assembly Maintenance For An XR-Edge Gun	32
6-3. Removing Contact Tip Adapter In XR-Edge Guns	33
6-4. Replacing Head Tube Liner In XR-Edge Guns	33
6-5. Replacing Gun Cable Liner	34
6-6. Changing Gun Contact Tip	35
6-7. Changing Or Cleaning Gun Drive Roll In Pistol-Grip Guns	35
6-8. Replacing Or Cleaning Gun Drive Roll Bearing In Pistol-Grip Guns	36
6-9. Changing Head Tube Liner In Pistol-Grip Guns	36
6-10. Removing Contact Tip Adapter In Air-Cooled Pistol-Grip Guns	37
6-11. Removing Contact Tip Adapter In Water-Cooled Pistol-Grip Guns	37

TABLE OF CONTENTS

6-12. Replacing Hub Assembly	38
6-13. Overload Protection	39
6-14. Water Flow Switch (Optional For Water-Cooled Models)	39
6-15. Troubleshooting	40
SECTION 7 – ELECTRICAL DIAGRAMS	42
SECTION 8 – PARTS LIST	46

Declaration of Conformity for European Community (CE) Products

Note  This information is provided for units with CE certification (see rating label on unit).

Manufacturer's Name: Miller Electric Mfg. Co.

Manufacturer's Address: 1635 W. Spencer Street
Appleton, WI 54914 USA

Declares that the product: **XR-Control**

conforms to the following Directives and Standards:

Directives

Low Voltage Directive: 73/23/EEC

Electromagnetic Compatibility (EMC) Directive: 89/336/EEC

Machinery Directives: 89/392/EEC, 91/368/EEC, 93/C 133/04, 93/68/EEC

Standards

Arc Welding Equipment Part I: Welding Power Sources: IEC 60974-1
(September 1998 – Second Edition)

Arc Welding Equipment: Wirefeed Systems: IEC 974-5
(September 1997 – Draft Revision)

Degrees of Protection Provided By Enclosures (IP Code): IEC 529:1989
(November 1989 - First Edition)

Insulation Coordination For Equipment With Low-Voltage Systems:
Part I: Principles, Requirements and Tests: IEC 664-1: 1992
(October 1992 – First Edition)

Electromagnetic Compatibility, (EMC): EN 50199
(August 1995)

Torches And Guns For Arc Welding, EN 50078

European Contact: Danilo Fedolfi, Managing Director
MILLER Europe S.r.l.
Via Privata Iseo
20098 San Giuliano
Milanese, Italy

Telephone: 39(02)98290-1
Fax: 39(02)98281-552

SECTION 1 – SAFETY PRECAUTIONS - READ BEFORE USING

som_nd_4/98

1-1. Symbol Usage



Means Warning! Watch Out! There are possible hazards with this procedure! The possible hazards are shown in the adjoining symbols.

▲ Marks a special safety message.

☞ Means "Note"; not safety related.



This group of symbols means Warning! Watch Out! possible ELECTRIC SHOCK, MOVING PARTS, and HOT PARTS hazards. Consult symbols and related instructions below for necessary actions to avoid the hazards.

1-2. Arc Welding Hazards

▲ The symbols shown below are used throughout this manual to call attention to and identify possible hazards. When you see the symbol, watch out, and follow the related instructions to avoid the hazard. The safety information given below is only a summary of the more complete safety information found in the Safety Standards listed in Section 1-4. Read and follow all Safety Standards.

▲ Only qualified persons should install, operate, maintain, and repair this unit.

▲ During operation, keep everybody, especially children, away.



ELECTRIC SHOCK can kill.

Touching live electrical parts can cause fatal shocks or severe burns. The electrode and work circuit is electrically live whenever the output is on. The input power circuit and machine internal circuits are also

live when power is on. In semiautomatic or automatic wire welding, the wire, wire reel, drive roll housing, and all metal parts touching the welding wire are electrically live. Incorrectly installed or improperly grounded equipment is a hazard.

- Do not touch live electrical parts.
- Wear dry, hole-free insulating gloves and body protection.
- Insulate yourself from work and ground using dry insulating mats or covers big enough to prevent any physical contact with the work or ground.
- Do not use AC output in damp areas, if movement is confined, or if there is a danger of falling.
- Use AC output ONLY if required for the welding process.
- If AC output is required, use remote output control if present on unit.
- Disconnect input power or stop engine before installing or servicing this equipment. Lockout/tagout input power according to OSHA 29 CFR 1910.147 (see Safety Standards).
- Properly install and ground this equipment according to its Owner's Manual and national, state, and local codes.
- Always verify the supply ground – check and be sure that input power cord ground wire is properly connected to ground terminal in disconnect box or that cord plug is connected to a properly grounded receptacle outlet.
- When making input connections, attach proper grounding conductor first – double-check connections.
- Frequently inspect input power cord for damage or bare wiring – replace cord immediately if damaged – bare wiring can kill.
- Turn off all equipment when not in use.
- Do not use worn, damaged, undersized, or poorly spliced cables.
- Do not drape cables over your body.

- If earth grounding of the workpiece is required, ground it directly with a separate cable.
- Do not touch electrode if you are in contact with the work, ground, or another electrode from a different machine.
- Use only well-maintained equipment. Repair or replace damaged parts at once. Maintain unit according to manual.
- Wear a safety harness if working above floor level.
- Keep all panels and covers securely in place.
- Clamp work cable with good metal-to-metal contact to workpiece or worktable as near the weld as practical.
- Insulate work clamp when not connected to workpiece to prevent contact with any metal object.
- Do not connect more than one electrode or work cable to any single weld output terminal.

SIGNIFICANT DC VOLTAGE exists after removal of input power on inverters.

- Turn Off inverter, disconnect input power, and discharge input capacitors according to instructions in Maintenance Section before touching any parts.

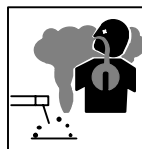

FUMES AND GASES can be hazardous.

Welding produces fumes and gases. Breathing these fumes and gases can be hazardous to your health.

- Keep your head out of the fumes. Do not breathe the fumes.
- If inside, ventilate the area and/or use exhaust at the arc to remove welding fumes and gases.
- If ventilation is poor, use an approved air-supplied respirator.
- Read the Material Safety Data Sheets (MSDSs) and the manufacturer's instructions for metals, consumables, coatings, cleaners, and degreasers.
- Work in a confined space only if it is well ventilated, or while wearing an air-supplied respirator. Always have a trained watch-person nearby. Welding fumes and gases can displace air and lower the oxygen level causing injury or death. Be sure the breathing air is safe.
- Do not weld in locations near degreasing, cleaning, or spraying operations. The heat and rays of the arc can react with vapors to form highly toxic and irritating gases.
- Do not weld on coated metals, such as galvanized, lead, or cadmium plated steel, unless the coating is removed from the weld area, the area is well ventilated, and if necessary, while wearing an air-supplied respirator. The coatings and any metals containing these elements can give off toxic fumes if welded.



ARC RAYS can burn eyes and skin.

Arc rays from the welding process produce intense visible and invisible (ultraviolet and infrared) rays that can burn eyes and skin. Sparks fly off from the weld.

- Wear a welding helmet fitted with a proper shade of filter to protect your face and eyes when welding or watching (see ANSI Z49.1 and Z87.1 listed in Safety Standards).
- Wear approved safety glasses with side shields under your helmet.
- Use protective screens or barriers to protect others from flash and glare; warn others not to watch the arc.
- Wear protective clothing made from durable, flame-resistant material (leather and wool) and foot protection.



WELDING can cause fire or explosion.

Welding on closed containers, such as tanks, drums, or pipes, can cause them to blow up. Sparks can fly off from the welding arc. The flying sparks, hot workpiece, and hot equipment can cause fires and

burns. Accidental contact of electrode to metal objects can cause sparks, explosion, overheating, or fire. Check and be sure the area is safe before doing any welding.

- Protect yourself and others from flying sparks and hot metal.
- Do not weld where flying sparks can strike flammable material.
- Remove all flammables within 35 ft (10.7 m) of the welding arc. If this is not possible, tightly cover them with approved covers.
- Be alert that welding sparks and hot materials from welding can easily go through small cracks and openings to adjacent areas.
- Watch for fire, and keep a fire extinguisher nearby.
- Be aware that welding on a ceiling, floor, bulkhead, or partition can cause fire on the hidden side.
- Do not weld on closed containers such as tanks, drums, or pipes, unless they are properly prepared according to AWS F4.1 (see Safety Standards).
- Connect work cable to the work as close to the welding area as practical to prevent welding current from traveling long, possibly unknown paths and causing electric shock and fire hazards.
- Do not use welder to thaw frozen pipes.
- Remove stick electrode from holder or cut off welding wire at contact tip when not in use.
- Wear oil-free protective garments such as leather gloves, heavy shirt, cuffless trousers, high shoes, and a cap.
- Remove any combustibles, such as a butane lighter or matches, from your person before doing any welding.

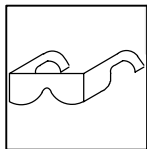

FLYING METAL can injure eyes.

- Welding, chipping, wire brushing, and grinding cause sparks and flying metal. As welds cool, they can throw off slag.
- Wear approved safety glasses with side shields even under your welding helmet.



BUILDUP OF GAS can injure or kill.

- Shut off shielding gas supply when not in use.
- Always ventilate confined spaces or use approved air-supplied respirator.



HOT PARTS can cause severe burns.

- Do not touch hot parts bare handed.
- Allow cooling period before working on gun or torch.

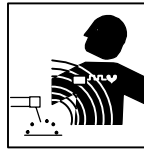

MAGNETIC FIELDS can affect pacemakers.

- Pacemaker wearers keep away.
- Wearers should consult their doctor before going near arc welding, gouging, or spot welding operations.

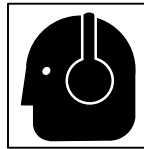

NOISE can damage hearing.

Noise from some processes or equipment can damage hearing.

- Wear approved ear protection if noise level is high.

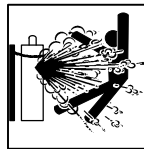

CYLINDERS can explode if damaged.

Shielding gas cylinders contain gas under high pressure. If damaged, a cylinder can explode. Since gas cylinders are normally part of the welding process, be sure to treat them carefully.

- Protect compressed gas cylinders from excessive heat, mechanical shocks, slag, open flames, sparks, and arcs.
- Install cylinders in an upright position by securing to a stationary support or cylinder rack to prevent falling or tipping.
- Keep cylinders away from any welding or other electrical circuits.
- Never drape a welding torch over a gas cylinder.
- Never allow a welding electrode to touch any cylinder.
- Never weld on a pressurized cylinder – explosion will result.
- Use only correct shielding gas cylinders, regulators, hoses, and fittings designed for the specific application; maintain them and associated parts in good condition.
- Turn face away from valve outlet when opening cylinder valve.
- Keep protective cap in place over valve except when cylinder is in use or connected for use.
- Read and follow instructions on compressed gas cylinders, associated equipment, and CGA publication P-1 listed in Safety Standards.

1-3. Additional Symbols For Installation, Operation, And Maintenance



FIRE OR EXPLOSION hazard.

- Do not install or place unit on, over, or near combustible surfaces.
- Do not install unit near flammables.
- Do not overload building wiring – be sure power supply system is properly sized, rated, and protected to handle this unit.



MOVING PARTS can cause injury.

- Keep away from moving parts such as fans.
- Keep all doors, panels, covers, and guards closed and securely in place.



FALLING UNIT can cause injury.

- Use lifting eye to lift unit only, NOT running gear, gas cylinders, or any other accessories.
- Use equipment of adequate capacity to lift and support unit.
- If using lift forks to move unit, be sure forks are long enough to extend beyond opposite side of unit.

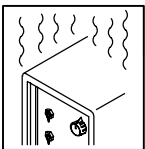

OVERUSE can cause OVERHEATING

- Allow cooling period; follow rated duty cycle.
- Reduce current or reduce duty cycle before starting to weld again.
- Do not block or filter airflow to unit.

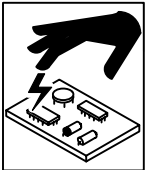

STATIC (ESD) can damage PC boards.

- Put on grounded wrist strap BEFORE handling boards or parts.
- Use proper static-proof bags and boxes to store, move, or ship PC boards.



MOVING PARTS can cause injury.

- Keep away from moving parts.
- Keep away from pinch points such as drive rolls.



WELDING WIRE can cause injury.

- Do not press gun trigger until instructed to do so.
- Do not point gun toward any part of the body, other people, or any metal when threading welding wire.

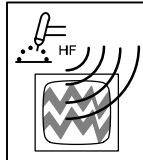

H.F. RADIATION can cause interference.

- High-frequency (H.F.) can interfere with radio navigation, safety services, computers, and communications equipment.
- Have only qualified persons familiar with electronic equipment perform this installation.
- The user is responsible for having a qualified electrician promptly correct any interference problem resulting from the installation.
- If notified by the FCC about interference, stop using the equipment at once.
- Have the installation regularly checked and maintained.
- Keep high-frequency source doors and panels tightly shut, keep spark gaps at correct setting, and use grounding and shielding to minimize the possibility of interference.

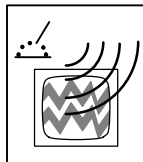

ARC WELDING can cause interference.

- Electromagnetic energy can interfere with sensitive electronic equipment such as computers and computer-driven equipment such as robots.
- Be sure all equipment in the welding area is electromagnetically compatible.
- To reduce possible interference, keep weld cables as short as possible, close together, and down low, such as on the floor.
- Locate welding operation 100 meters from any sensitive electronic equipment.
- Be sure this welding machine is installed and grounded according to this manual.
- If interference still occurs, the user must take extra measures such as moving the welding machine, using shielded cables, using line filters, or shielding the work area.

1-4. Principal Safety Standards

Safety in Welding and Cutting, ANSI Standard Z49.1, from American Welding Society, 550 N.W. LeJeune Rd, Miami FL 33126

Safety and Health Standards, OSHA 29 CFR 1910, from Superintendent of Documents, U.S. Government Printing Office, Washington, D.C. 20402.

Recommended Safe Practices for the Preparation for Welding and Cutting of Containers That Have Held Hazardous Substances, American Welding Society Standard AWS F4.1, from American Welding Society, 550 N.W. LeJeune Rd, Miami, FL 33126

National Electrical Code, NFPA Standard 70, from National Fire Protection Association, Batterymarch Park, Quincy, MA 02269.

Safe Handling of Compressed Gases in Cylinders, CGA Pamphlet P-1, from Compressed Gas Association, 1235 Jefferson Davis Highway, Suite 501, Arlington, VA 22202.

Code for Safety in Welding and Cutting, CSA Standard W117.2, from Canadian Standards Association, Standards Sales, 178 Rexdale Boulevard, Rexdale, Ontario, Canada M9W 1R3.

Safe Practices For Occupation And Educational Eye And Face Protection, ANSI Standard Z87.1, from American National Standards Institute, 1430 Broadway, New York, NY 10018.

Cutting And Welding Processes, NFPA Standard 51B, from National Fire Protection Association, Batterymarch Park, Quincy, MA 02269.

1-5. EMF Information

Considerations About Welding And The Effects Of Low Frequency Electric And Magnetic Fields

Welding current, as it flows through welding cables, will cause electromagnetic fields. There has been and still is some concern about such fields. However, after examining more than 500 studies spanning 17 years of research, a special blue ribbon committee of the National Research Council concluded that: "The body of evidence, in the committee's judgment, has not demonstrated that exposure to power-frequency electric and magnetic fields is a human-health hazard." However, studies are still going forth and evidence continues to be examined. Until the final conclusions of the research are reached, you may wish to minimize your exposure to electromagnetic fields when welding or cutting.

To reduce magnetic fields in the workplace, use the following procedures:

1. Keep cables close together by twisting or taping them.
2. Arrange cables to one side and away from the operator.
3. Do not coil or drape cables around your body.
4. Keep welding power source and cables as far away from operator as practical.
5. Connect work clamp to workpiece as close to the weld as possible.

About Pacemakers:

Pacemaker wearers consult your doctor first. If cleared by your doctor, then following the above procedures is recommended.

SECTION 1 – CONSIGNES DE SECURITE – LIRE AVANT UTILISATION

som_nd_fre 4/98

1-1. Signification des symboles



Signifie Mise en garde ! Soyez vigilant ! Cette procédure présente des risques de danger ! Ceux-ci sont identifiés par des symboles adjacents aux directives.

▲ Identifie un message de sécurité particulier.

Signifie NOTA ; n'est pas relatif à la sécurité.



Ce groupe de symboles signifie Mise en garde ! Soyez vigilant ! Il y a des risques de danger reliés aux CHOCS ÉLECTRIQUES, aux PIÈCES EN MOUVEMENT et aux PIÈCES CHAUDES. Reportez-vous aux symboles et aux directives ci-dessous afin de connaître les mesures à prendre pour éviter tout danger.

1-2. Dangers relatifs au soudage à l'arc

▲ Les symboles présentés ci-après sont utilisés tout au long du présent manuel pour attirer votre attention et identifier les risques de danger. Lorsque vous voyez un symbole, soyez vigilant et suivez les directives mentionnées afin d'éviter tout danger. Les consignes de sécurité présentées ci-après ne font que résumer l'information contenue dans les normes de sécurité énumérées à la section 1-4. Veuillez lire et respecter toutes ces normes de sécurité.

▲ L'installation, l'utilisation, l'entretien et les réparations ne doivent être confiés qu'à des personnes qualifiées.

▲ Au cours de l'utilisation, tenir toute personne à l'écart et plus particulièrement les enfants.



UN CHOC ÉLECTRIQUE peut tuer.

Un simple contact avec des pièces électriques peut provoquer une électrocution ou des blessures graves. L'électrode et le circuit de soudage sont sous tension dès que l'appareil est sur ON. Le circuit d'entrée et les circuits internes de l'appareil sont également sous tension à ce moment-là. En soudage semi-automatique ou automatique, le fil, le dévidoir, le logement des galets d'entraînement et les pièces métalliques en contact avec le fil de soudage sont sous tension. Des matériels mal installés ou mal mis à la terre présentent un danger.

- Ne jamais toucher les pièces électriques sous tension.
- Porter des gants et des vêtements de protection secs ne comportant pas de trous.
- S'isoler de la pièce et de la terre au moyen de tapis ou d'autres moyens isolants suffisamment grands pour empêcher le contact physique éventuel avec la pièce ou la terre.
- Ne pas se servir de source électrique à courant électrique dans les zones humides, dans les endroits confinés ou là où on risque de tomber.
- Se servir d'une source électrique à courant électrique UNIQUEMENT si le procédé de soudage le demande.
- Si l'utilisation d'une source électrique à courant électrique s'avère nécessaire, se servir de la fonction de télécommande si l'appareil en est équipé.
- Couper l'alimentation ou arrêter le moteur avant de procéder à l'installation, à la réparation ou à l'entretien de l'appareil. Déverrouiller l'alimentation selon la norme OSHA 29 CFR 1910.147 (voir normes de sécurité).
- Installer et mettre à la terre correctement cet appareil conformément à son manuel d'utilisation et aux codes nationaux, provinciaux et municipaux.
- Toujours vérifier la terre du cordon d'alimentation – Vérifier et s'assurer que le fil de terre du cordon d'alimentation est bien raccordé à la borne de terre du sectionneur ou que la fiche du cordon est raccordée à une prise correctement mise à la terre.
- En effectuant les raccordements d'entrée fixer d'abord le conducteur de mise à la terre approprié et contre-vérifier les connexions.
- Vérifier fréquemment le cordon d'alimentation pour voir s'il n'est pas endommagé ou dénudé – remplacer le cordon immédiatement s'il est endommagé – un câble dénudé peut provoquer une électrocution.
- Mettre l'appareil hors tension quand on ne l'utilise pas.
- Ne pas utiliser des câbles usés, endommagés, de grosseur insuffisante ou mal épissés.
- Ne pas enrouler les câbles autour du corps.
- Si la pièce soudée doit être mise à la terre, le faire directement avec un câble distinct.
- Ne pas toucher l'électrode quand on est en contact avec la pièce, la terre ou une électrode provenant d'une autre machine.

- N'utiliser qu'un matériel en bon état. Réparer ou remplacer sur-le-champ les pièces endommagées. Entretien l'appareil conformément à ce manuel.
- Porter un harnais de sécurité quand on travaille en hauteur.
- Maintenir solidement en place tous les panneaux et capots.
- Fixer le câble de retour de façon à obtenir un bon contact métal-métal avec la pièce à souder ou la table de travail, le plus près possible de la soudure.
- Isoler la pince de masse quand pas mis à la pièce pour éviter le contact avec tout objet métallique.

Il y a DU COURANT CONTINU IMPORTANT dans les convertisseurs après la suppression de l'alimentation électrique.

- Arrêter les convertisseurs, débrancher le courant électrique, et décharger les condensateurs d'alimentation selon les instructions indiquées dans la partie entretien avant de toucher les pièces.

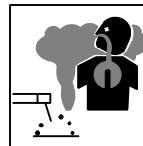

LES FUMÉES ET LES GAZ peuvent être dangereux.

Le soudage génère des fumées et des gaz. Leur inhalation peut être dangereuse pour votre santé.

- Eloigner votre tête des fumées. Ne pas respirer les fumées.
- A l'intérieur, ventiler la zone et/ou utiliser un échappement au niveau de l'arc pour l'évacuation des fumées et des gaz de soudage.
- Si la ventilation est insuffisante, utiliser un respirateur à alimentation d'air homologué.
- Lire les spécifications de sécurité des matériaux (MSDSs) et les instructions du fabricant concernant les métaux, les consommables, les revêtements, les nettoyants et les dégraissants.
- Travailler dans un espace fermé seulement s'il est bien ventilé ou en portant un respirateur à alimentation d'air. Demander toujours à un surveillant dûment formé de se tenir à proximité. Des fumées et des gaz de soudage peuvent déplacer l'air et abaisser le niveau d'oxygène provoquant des blessures ou des accidents mortels. S'assurer que l'air de respiration ne présente aucun danger.
- Ne pas souder dans des endroits situés à proximité d'opérations de dégraissage, de nettoyage ou de pulvérisation. La chaleur et les rayons de l'arc peuvent réagir en présence de vapeurs et former des gaz hautement toxiques et irritants.
- Ne pas souder des métaux munis d'un revêtement, tels que l'acier galvanisé, plaqué en plomb ou au cadmium à moins que le revêtement n'ait été enlevé dans la zone de soudure, que l'endroit soit bien ventilé, et si nécessaire, en portant un respirateur à alimentation d'air. Les revêtements et tous les métaux renfermant ces éléments peuvent dégager des fumées toxiques en cas de soudage.



LES RAYONS DE L'ARC peuvent provoquer des brûlures dans les yeux et sur la peau.

Le rayonnement de l'arc du procédé de soudage génère des rayons visibles et invisibles intenses (ultraviolets et infrarouges) susceptibles de provoquer des brûlures dans les yeux et sur la peau. Des étincelles sont projetées pendant le soudage.

- Porter un casque de soudage muni d'un écran de filtre approprié pour protéger votre visage et vos yeux pendant le soudage ou pour regarder (voir ANSI Z49.1 et Z87.1 énuméré dans les normes de sécurité).
- Porter des protections approuvés pour les oreilles si le niveau sonore est trop élevé.
- Utiliser des écrans ou des barrières pour protéger des tiers de l'éclair et de l'éblouissement; demander aux autres personnes de ne pas regarder l'arc.
- Porter des vêtements de protection constitué dans une matière durable, résistant au feu (cuir ou laine) et une protection des pieds.



LE SOUDAGE peut provoquer un incendie ou une explosion.

Le soudage effectué sur des conteneurs fermés tels que des réservoirs, tambours ou des conduites peut provoquer leur éclatement. Des étincelles peuvent être projetées de l'arc de soudure. La projection d'étincelles, des pièces chaudes et des équipements chauds peut provoquer des incendies et des brûlures. Le contact accidentel de l'électrode avec des objets métalliques peut provoquer des étincelles, une explosion, un surchauffement ou un incendie. Avant de commencer le soudage, vérifier et s'assurer que l'endroit ne présente pas de danger.

- Se protéger et d'autres personnes de la projection d'étincelles et de métal chaud.
- Ne pas souder dans un endroit là où des étincelles peuvent tomber sur des substances inflammables.
- Déplacer toutes les substances inflammables à une distance de 10,7 m de l'arc de soudage. En cas d'impossibilité les recouvrir soigneusement avec des protections homologués.
- Des étincelles et des matériaux chauds du soudage peuvent facilement passer dans d'autres zones en traversant de petites fissures et des ouvertures.
- Surveiller tout déclenchement d'incendie et tenir un extincteur à proximité.
- Le soudage effectué sur un plafond, plancher, paroi ou séparation peut déclencher un incendie de l'autre côté.
- Ne pas effectuer le soudage sur des conteneurs fermés tels que des réservoirs, tambours, ou conduites, à moins qu'ils n'aient été préparés correctement conformément à AWS F4.1 (voir les normes de sécurité).
- Brancher le câble sur la pièce le plus près possible de la zone de soudage pour éviter le transport du courant sur une longue distance par des chemins inconnus éventuels en provoquant des risques d'électrocution et d'incendie.
- Ne pas utiliser le poste de soudage pour décongeler des conduites gelées.
- En cas de non utilisation, enlever la baguette d'électrode du porte-électrode ou couper le fil à la pointe de contact.
- Porter des vêtements de protection dépourvus d'huile tels que des gants en cuir, une chemise en matériau lourd, des pantalons sans revers, des chaussures hautes et un couvre chef.
- Avant de souder, retirer toute substance combustible de vos poches telles qu'un allumeur au butane ou des allumettes.

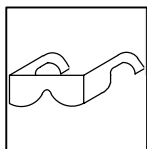

DES PARTICULES VOLANTES peuvent blesser les yeux.

- Le soudage, l'écaillage, le passage de la pièce à la brosse en fil de fer, et le meulage génèrent des étincelles et des particules métalliques volantes. Pendant la période de refroidissement des soudures, elles risquent de projeter du laitier.
- Porter des lunettes de sécurité avec écrans latéraux ou un écran facial.



LES ACCUMULATIONS DE GAZ risquent de provoquer des blessures ou même la mort.

- Fermer l'alimentation du gaz protecteur en cas de non utilisation.
- Veiller toujours à bien aérer les espaces confinés ou se servir d'un respirateur d'adduction d'air homologué.



DES PIÈCES CHAUDES peuvent provoquer des brûlures graves.

- Ne pas toucher des parties chaudes à mains nues
- Prévoir une période de refroidissement avant d'utiliser le pistolet ou la torche.

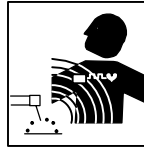

LES CHAMPS MAGNÉTIQUES peuvent affecter les stimulateurs cardiaques.

- Porteurs de stimulateur cardiaque, restez à distance.
- Les porteurs d'un stimulateur cardiaque doivent d'abord consulter leur médecin avant de s'approcher des opérations de soudage à l'arc, de gougeage ou de soudage par points.

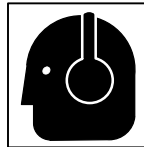

LE BRUIT peut affecter l'ouïe.

Le bruit des processus et des équipements peut affecter l'ouïe.

- Porter des protections approuvés pour les oreilles si le niveau sonore est trop élevé.

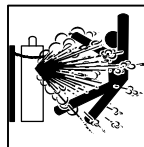

Si des BOUTEILLES sont endommagées, elles pourront exploser.

Des bouteilles de gaz protecteur contiennent du gaz sous haute pression. Si une bouteille est endommagée, elle peut exploser. Du fait que les bouteilles de gaz font normalement partie du procédé de soudage, les manipuler avec précaution.

- Protéger les bouteilles de gaz comprimé d'une chaleur excessive, des chocs mécaniques, du laitier, des flammes ouvertes, des étincelles et des arcs.
- Placer les bouteilles debout en les fixant dans un support stationnaire ou dans un porte-bouteilles pour les empêcher de tomber ou de se renverser.
- Tenir les bouteilles éloignées des circuits de soudage ou autres circuits électriques.
- Ne jamais placer une torche de soudage sur une bouteille à gaz.
- Une électrode de soudage ne doit jamais entrer en contact avec une bouteille.
- Ne jamais souder une bouteille pressurisée – risque d'explosion.
- Utiliser seulement des bouteilles de gaz protecteur, régulateurs, tuyaux et raccords convenables pour cette application spécifique; les maintenir ainsi que les éléments associés en bon état.
- Ne pas tenir la tête en face de la sortie en ouvrant la soupape de la bouteille.
- Maintenir le chapeau de protection sur la soupape, sauf en cas d'utilisation ou de branchement de la bouteille.
- Lire et suivre les instructions concernant les bouteilles de gaz comprimé, les équipements associés et les publications P-1 CGA énumérées dans les normes de sécurité.

1-3. Dangers supplémentaires en relation avec l'installation, le fonctionnement et la maintenance



Risque D'INCENDIE OU D'EXPLOSION.

- Ne pas placer l'appareil sur, au-dessus ou à proximité de surfaces inflammables.
- Ne pas installer l'appareil à proximité de produits inflammables
- Ne pas surcharger l'installation électrique – s'assurer que l'alimentation est correctement dimensionnée et protégée avant de mettre l'appareil en service.



LA CHUTE DE L'APPAREIL peut blesser.

- Utiliser l'anneau de levage uniquement pour soulever l'appareil, NON PAS les chariot, les bouteilles de gaz ou tout autre accessoire.
- Utiliser un engin d'une capacité appropriée pour soulever l'appareil.
- En utilisant des fourches de levage pour déplacer l'unité, s'assurer que les fourches sont suffisamment longues pour dépasser du côté opposé de l'appareil.

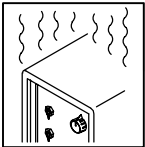

L'EMPLOI EXCESSIF peut SURCHAUFFER L'ÉQUIPEMENT.

- Prévoir une période de refroidissement, respecter le cycle opératoire nominal.
- Réduire le courant ou le cycle opératoire avant de recommencer le soudage.
- Ne pas obstruer les passages d'air du poste.

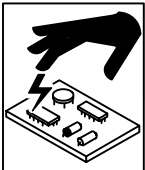

LES CHARGES ÉLECTROSTATIQUES peuvent endommager les circuits imprimés.

- Établir la connexion avec la barrette de terre avant de manipuler des cartes ou des pièces.
- Utiliser des pochettes et des boîtes antistatiques pour stocker, déplacer ou expédier des cartes de circuits imprimés.



DES ORGANES MOBILES peuvent provoquer des blessures.

- Ne pas s'approcher des organes mobiles.
- Ne pas s'approcher des points de coincement tels que des rouleaux de commande.



LES FILS DE SOUDAGE peuvent provoquer des blessures.

- Ne pas appuyer sur la gachette avant d'en avoir reçu l'instruction.
- Ne pas diriger le pistolet vers soi, d'autres personnes ou toute pièce mécanique en engageant le fil de soudage.



DES ORGANES MOBILES peuvent provoquer des blessures.

- Rester à l'écart des organes mobiles comme le ventilateur.
- Maintenir fermés et fixement en place les portes, panneaux, recouvrements et dispositifs de protection.

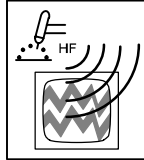

LE RAYONNEMENT HAUTE FRÉQUENCE (H.F.) risque de provoquer des interférences.

- Le rayonnement haute fréquence peut provoquer des interférences avec les équipements de radio-navigation et de communication, les services de sécurité et les ordinateurs.
- Demander seulement à des personnes qualifiées familiarisées avec des équipements électroniques de faire fonctionner l'installation.
- L'utilisateur est tenu de faire corriger rapidement par un électricien qualifié les interférences résultant de l'installation.
- Si le FCC signale des interférences, arrêter immédiatement l'appareil.
- Effectuer régulièrement le contrôle et l'entretien de l'installation.
- Maintenir soigneusement fermés les portes et les panneaux des sources de haute fréquence, maintenir les éclateurs à une distance correcte et utiliser une terre et un blindage pour réduire les interférences éventuelles.

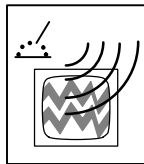

LE SOUDAGE À L'ARC risque de provoquer des interférences.

- L'énergie électromagnétique risque de provoquer des interférences pour l'équipement électronique sensible tel que les ordinateurs et l'équipement commandé par ordinateur tel que les robots.
- Veiller à ce que tout l'équipement de la zone de soudage soit compatible électromagnétiquement.
- Pour réduire la possibilité d'interférence, maintenir les câbles de soudage aussi courts que possible, les grouper, et les poser aussi bas que possible (ex. par terre).
- Veiller à souder à une distance de 100 mètres de tout équipement électronique sensible.
- Veiller à ce que ce poste de soudage soit posé et mis à la terre conformément à ce mode d'emploi.
- En cas d'interférences après avoir pris les mesures précédentes, il incombe à l'utilisateur de prendre des mesures supplémentaires telles que le déplacement du poste, l'utilisation de câbles blindés, l'utilisation de filtres de ligne ou la pose de protecteurs dans la zone de travail.

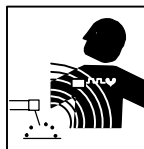

LES CHAMPS MAGNÉTIQUES peuvent affecter les stimulateurs cardiaques.

- Porteurs de stimulateur cardiaque, restez à distance.
- Les porteurs d'un stimulateur cardiaque doivent d'abord consulter leur médecin avant de s'approcher des opérations de soudage à l'arc, de gougeage ou de soudage par points.

1-4. Principales normes de sécurité

Safety in Welding and Cutting, norme ANSI Z49.1, de l'American Welding Society, 550 N.W. Lejeune Rd, Miami FL 33126

Safety and Health Standards, OSHA 29 CFR 1910, du Superintendent of Documents, U.S. Government Printing Office, Washington, D.C. 20402.

Recommended Safe Practice for the Preparation for Welding and Cutting of Containers That Have Held Hazardous Substances, norme AWS F4.1, de l'American Welding Society, 550 N.W. Lejeune Rd, Miami FL 33126

National Electrical Code, NFPA Standard 70, de la National Fire Protection Association, Batterymarch Park, Quincy, MA 02269.

Safe Handling of Compressed Gases in Cylinders, CGA Pamphlet P-1, de la Compressed Gas Association, 1235 Jefferson Davis Highway, Suite 501, Arlington, VA 22202.

Règles de sécurité en soudage, coupage et procédés connexes, norme CSA W117.2, de l'Association canadienne de normalisation, vente de normes, 178 Rexdale Boulevard, Rexdale (Ontario) Canada M9W 1R3.

Safe Practices For Occupation And Educational Eye And Face Protection, norme ANSI Z87.1, de l'American National Standards Institute, 1430 Broadway, New York, NY 10018.

Cutting and Welding Processes, norme NFPA 51B, de la National Fire Protection Association, Batterymarch Park, Quincy, MA 02269.

1-5. Information sur les champs électromagnétiques

Données sur le soudage électrique et sur les effets, pour l'organisme, des champs magnétiques basse fréquence

Le courant de soudage, pendant son passage dans les câbles de soudage, causera des champs électromagnétiques. Il y a eu et il y a encore un certain souci à propos de tels champs. Cependant, après avoir examiné plus de 500 études qui ont été faites pendant une période de recherche de 17 ans, un comité spécial ruban bleu du National Research Council a conclu: "L'accumulation de preuves, suivant le jugement du comité, n'a pas démontré que l'exposition aux champs magnétiques et champs électriques à haute fréquence représente un risque à la santé humaine". Toutefois, des études sont toujours en cours et les preuves continuent à être examinées. En attendant que les conclusions finales de la recherche soient établies, il vous serait souhaitable de réduire votre exposition aux champs électromagnétiques pendant le soudage ou le coupage.

Afin de réduire les champs électromagnétiques dans l'environnement de travail, respecter les consignes suivantes :

- 1 Garder les câbles ensemble en les torsadant ou en les attachant avec du ruban adhésif.
- 2 Mettre tous les câbles du côté opposé de l'opérateur.
- 3 Ne pas courber pas et ne pas entourer pas les câbles autour de votre corps.
- 4 Garder le poste de soudage et les câbles le plus loin possible de vous.
- 5 Relier la pince de masse le plus près possible de la zone de soudure.

Consignes relatives aux stimulateurs cardiaques :

Les personnes qui portent un stimulateur cardiaque doivent avant tout consulter leur docteur. Si vous êtes déclaré apte par votre docteur, il est alors recommandé de respecter les consignes ci-dessus.

SECTION 2 – DEFINITIONS

2-1. Warning Label Definitions



- A. Warning! Watch Out! There are possible hazards as shown by the symbols.
- B. Drive rolls can injure fingers.
- C. Welding wire and drive parts are at welding voltage during operation – keep hands and metal objects clear.
 - 1 Electric shock can kill.
 - 1.1 Wear dry insulating gloves. Do not touch electrode with bare hand. Do not wear wet or damaged gloves.
 - 1.2 Protect yourself from electric shock by insulating yourself from work and ground.
 - 1.3 Disconnect input plug or power before working on machine.
- 2 Breathing welding fumes can be hazardous to your health.
 - 2.1 Keep your head out of the fumes.
 - 2.2 Use forced ventilation or local exhaust to remove the fumes.
 - 2.3 Use ventilating fan to remove fumes.
- 3 Welding sparks can cause explosion or fire.
 - 3.1 Keep flammables away from welding. Don't weld near flammables.
 - 3.2 Welding sparks can cause fires. Have a fire extinguisher nearby and have a watch person ready to use it.
 - 3.3 Do not weld on drums or any closed containers.
- 4 Arc rays can burn eyes and injure skin.
 - 4.1 Wear hat and safety glasses. Use ear protection and button shirt collar. Use welding helmet with correct shade of filter. Wear complete body protection.
- 5 Become trained and read the instructions before working on the machine or welding.
- 6 Do not remove or paint over (cover) the label.

- 1 Read the Owner's Manual.
- 2 Do not overtighten wire spool brake pressure. Tighten only until wire does not overspool from wire supply spool.
- 3 Do not overtighten drive roll pressure. Tighten only until drive roll will not slip (motor will not stall) on a stationary wire.

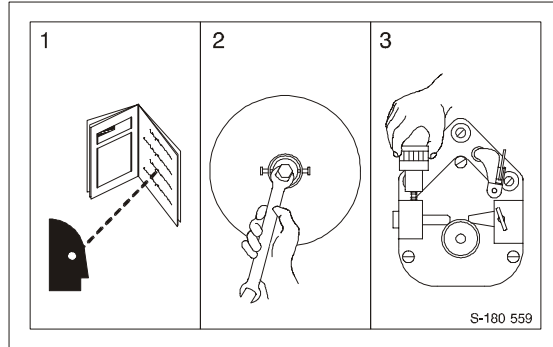



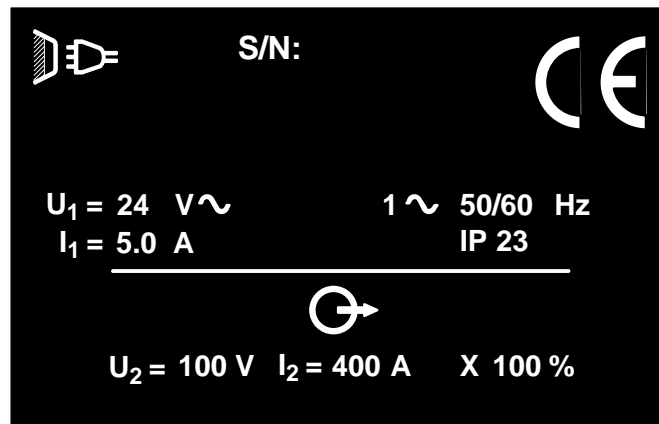



















2-2. Rating Label For CE Products



ST-178 794-A

2-3. Symbols And Definitions

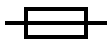
Note  Some symbols are found only on CE products.

A Amperes	V Volts	 Alternating Current	X Duty Cycle
IP Degree Of Protection	Hz Hertz	 Circuit Breaker	 Wire Feed
 Jog	 Output	 Trigger	 Gun
 Press To Set	 Increase	 Trigger Hold On	 Trigger Hold Off
 Purge	 Spot Weld Time	% Percent	 Run-In
 Burnback Time	U₁ Primary Voltage	U₂ Load Voltage	 Read Instructions
I₁ Primary Current	I₂ Rated Current	 Line Connection	 Water (Coolant) Input
 Water (Coolant) Output	 Fuse	 Continuous Spot Welding	

SECTION 3 – INTRODUCTION

3-1. Specifications

Type of Input Power	Welding Power Source Type	Wire Feed Speed Range	Wire Diameter Range	Welding Circuit Rating	Overall Dimensions	Weight
24 Volts AC Single-Phase 5 Amperes 50/60 Hertz	Constant Voltage (CV) DC For GMAW Or Constant Voltage(CV) / Constant Current (CC) DC For GMAW-P All Need 14-Pin And Contactor Control	70 To 875 ipm (1.8 To 22.2 mpm)	.030 To .062 in (0.8 To 1.6 mm) Max Spool Capacity: 12 in (305 mm)	All Models: 100% Duty Cycle, 100 Volts; Water-Cooled Models: 400 Amperes, Air-Cooled Models: 200 Amperes	Length: 21-1/4 in (540 mm) Width: 9-1/2 in (241 mm) Height: 16 in (406 mm)	38 lb (17.2 kg)

3-2. Duty Cycle And Overheating



Duty Cycle is percentage of 10 minutes that unit can weld at rated load without overheating.

▲ Exceeding duty cycle can damage unit and void warranty.

Air-Cooled Models

100% Duty Cycle At 200 Amperes Using Argon

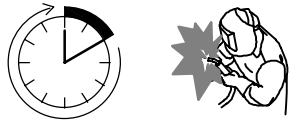

Continuous Welding

60% Duty Cycle At 250 Amperes Using Argon

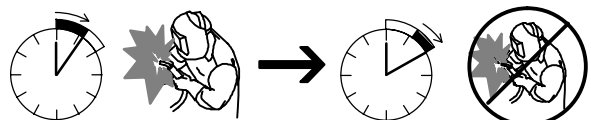

6 Minutes Welding

4 Minutes Resting

Water-Cooled Models

100% Duty Cycle At 400 Amperes Using Argon

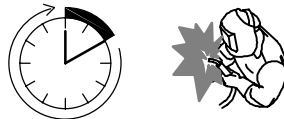

Continuous Welding

sduty1 5/95

SECTION 4 – INSTALLATION

NOTE

Be sure that contact tip, liner, and drive rolls are correct for wire size and type. See Parts List to change parts as needed.

NOTE

Many procedures apply to both guns covered in this manual. Where procedures differ, separate instructions are given.

4-1. Connections With A Constant Current (CC), Constant Voltage (CV) Or Constant Current/Constant Voltage (CC/CV) Welding Power Source Having A 14-Socket Receptacle

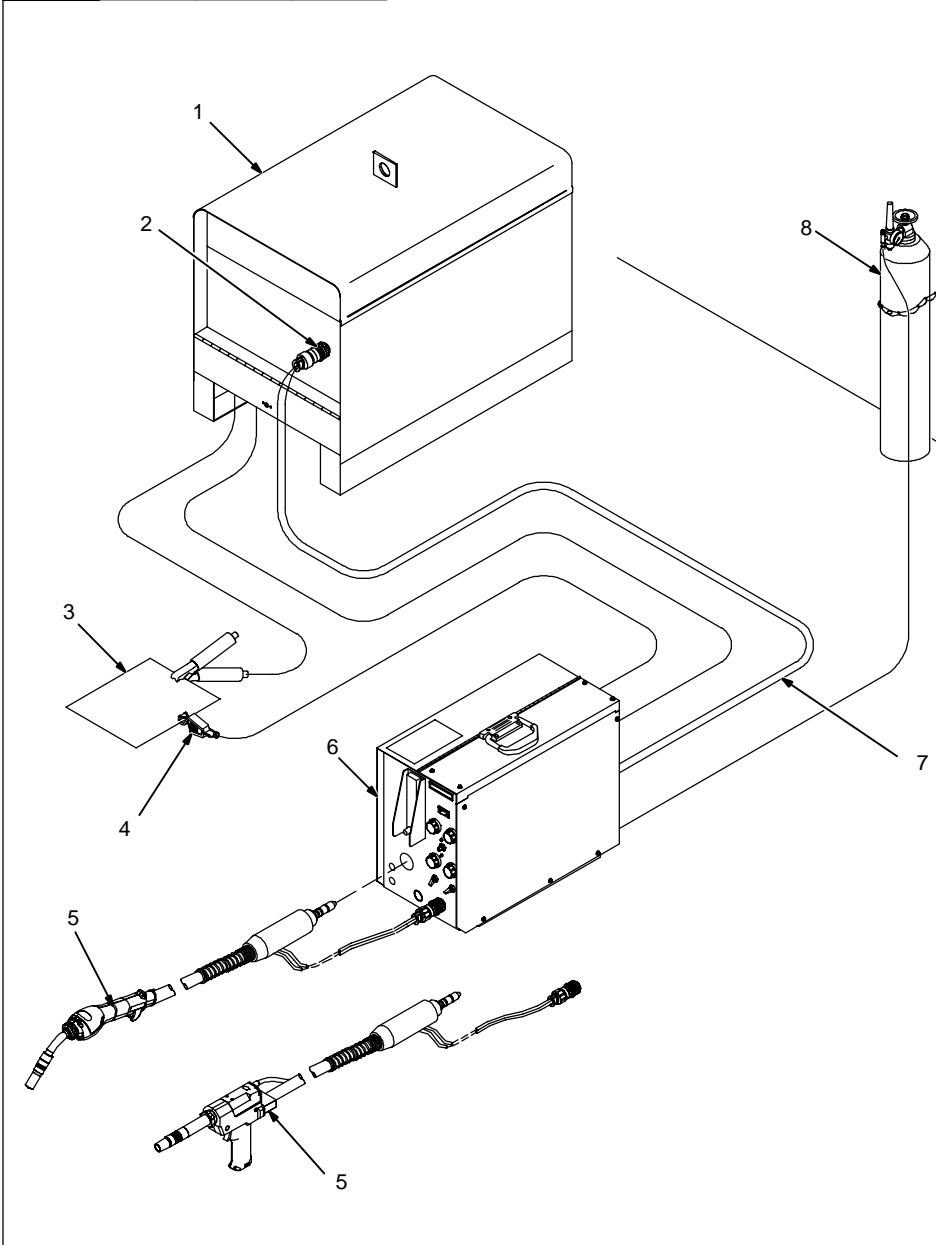

- 1 CC, CV Or CC/CV Welding Power Source
- 2 24 VAC/Contactor Control 14-Pin Plug
- 3 Workpiece
- 4 Voltage Sensing Lead (Optional)

Connect lead to workpiece for CC welding only.

- 5 Gun
- 6 Wire Feeder
- 7 24 VAC/Contactor Control Cord

▲ Do not use gas pressure above 50 psi (345 kPa).

- 8 Gas Cylinder

4-2. Air-Cooled Feeder Connections

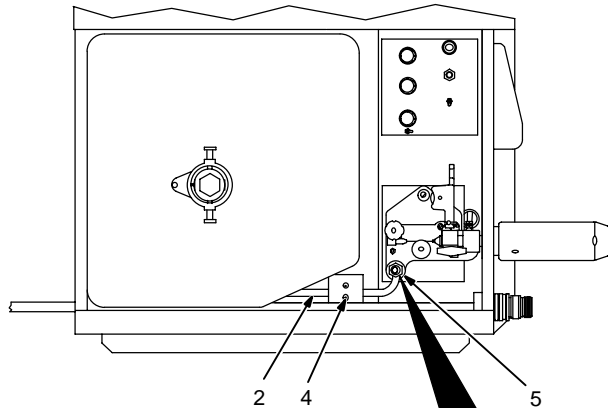

Rear Panel

Connect To 14-socket Receptacle On Welding Power Source

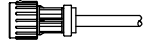

Connect To Positive (+) Weld Output Terminal On Welding Power Source

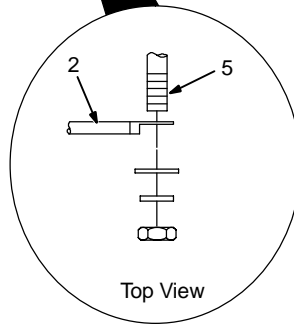

1 Gas Fitting

Route one end of 10 ft (3 m) gas hose to rear of unit, and connect hose to gas solenoid fitting. Connect remaining end of hose to regulator/flowmeter

2 Weld Cable To Welding Power Source

Select and prepare weld cable according to welding power source manual.

3 Weld Cable Grommet

4 Current Sensing (Reed) Relay

5 Weld Cable Terminal In Feeder

Route one end of weld cable through grommet, through reed relay, and connect to weld cable terminal in feeder. Connect remaining end of cable to positive (+) weld output terminal on welding power source.

Close and latch door.

Tools Needed:

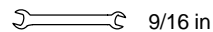

Ref. 801 578-A

4-3. Air-Cooled Gun Connections

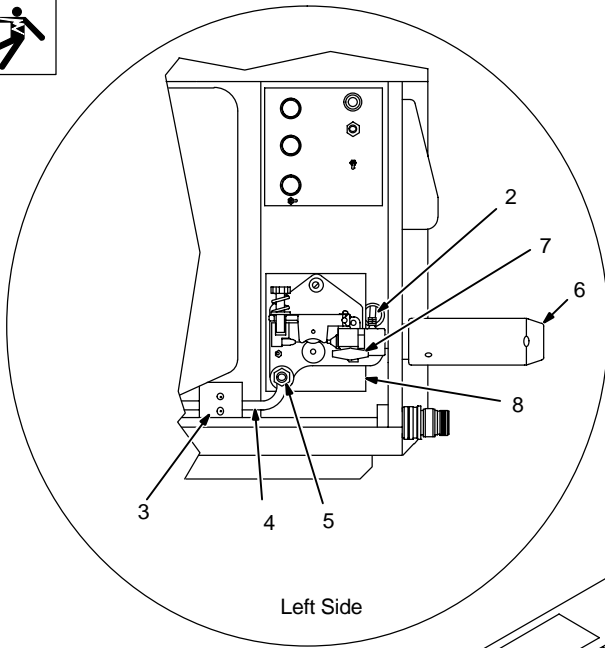

1 Gun Control Cable
 Insert plug into Gun Control receptacle, and tighten threaded collar.

- 2 Gas Hose
- 3 Reed Relay
- 4 Weld Cable
- 5 Weld Cable Terminal In Feeder

Route weld cable from welding power source through reed relay to weld cable terminal in feeder and connect to weld cable terminal.

- 6 Gun Connector
- 7 Gun Securing Knob
- 8 Gun Connector Block

Loosen gun securing knob, and insert gun connector through Wire opening until it bottoms against block. Tighten knob. Close and latch door.

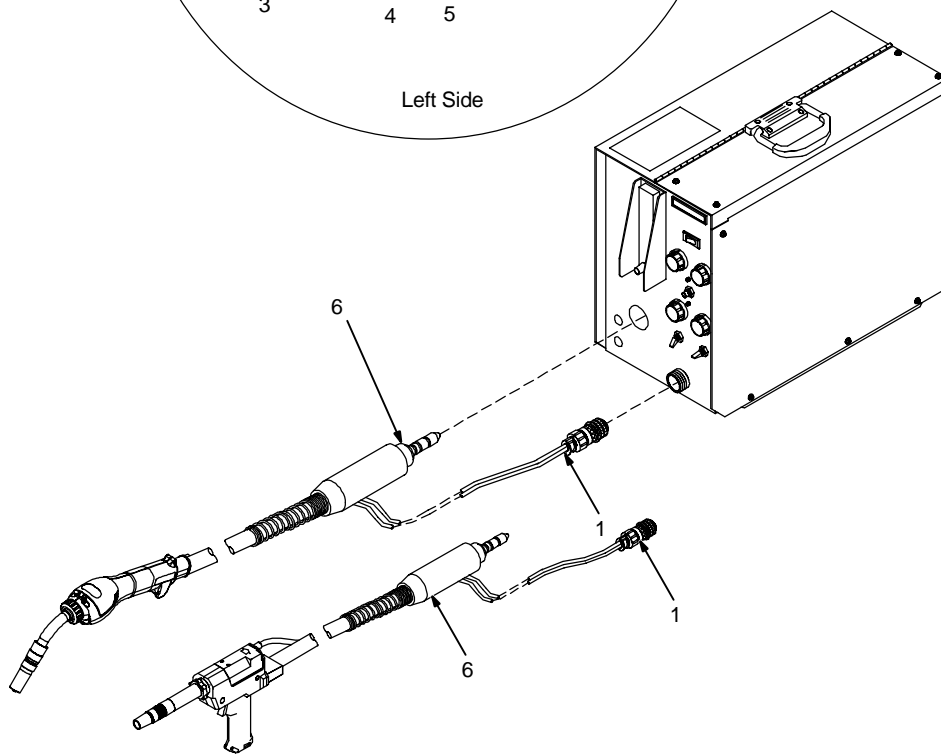

Tools Needed:

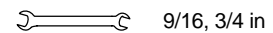

Ref. 801 577-A / 801 564-B / Ref. 151 666-B

4-4. Water-Cooled Feeder Connections

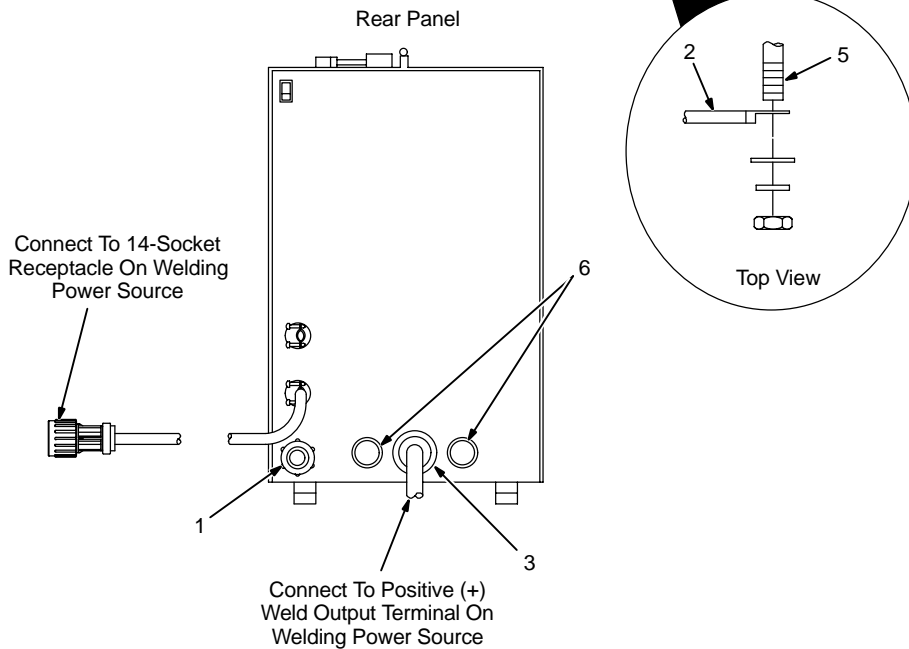
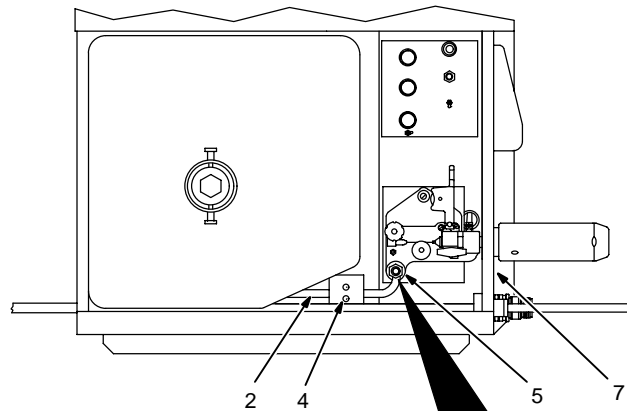

Obtain coolant supply.

1 Gas Fitting

Route one end of 10 ft (3 m) gas hose to rear of unit, and connect hose to gas solenoid fitting. Connect remaining end of hose to regulator/flowmeter

2 Weld Cable To Welding Power Source

Select and prepare weld cable according to welding power source manual.

3 Weld Cable Grommet

4 Current Sensing (Reed) Relay
5 Weld Cable Terminal In Feeder

Route one end of weld cable through grommet, through reed relay, and connect to weld cable terminal in feeder. Connect remaining end of cable to positive (+) weld output terminal on welding power source.

6 Coolant Hose Grommet

7 Location Of Coolant Fittings On Front Panel

Route one end of a coolant hose through grommet, and connect to rear of Coolant Out fitting in feeder. Connect remaining end to supply fitting on coolant supply.

Route one end of remaining coolant hose through grommet, and connect to rear of Coolant In fitting in feeder. Connect remaining end of hose to return fitting on coolant supply.

Close and latch door.

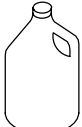
Application	GTAW Or Where HF* Is Used	GMAW Or Where Coolant Contacts Aluminum Parts Or Where HF* Not Used
 Coolant	MILLER Low Conductivity Coolant No. 043 810**	MILLER Aluminum Protecting Coolant No. 043 809**; Distilled Or Deionized Water OK Above 32° F (0° C)

*HF: High Frequency Current

**MILLER coolants protect to -37° F (-38°C) and resist algae growth.

Tools Needed:
 9/16 in

Ref. 152 431-A / Ref. 801 578-A

4-5. Water-Cooled Gun Connections

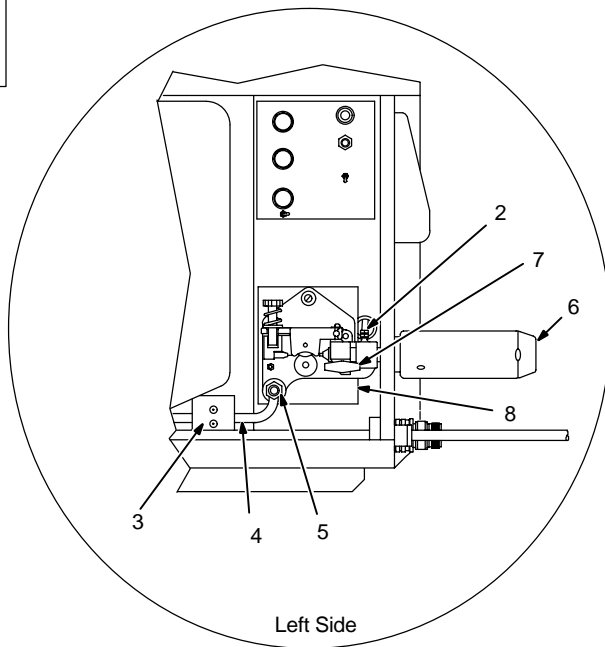

1 Gun Control Cable

Insert plug into Gun Control receptacle, and tighten threaded collar.

2 Gas Hose

3 Reed Relay

4 Weld Cable

5 Weld Cable Terminal In Feeder

Route weld cable from welding power source through reed relay to weld cable terminal in feeder and connect to weld cable terminal.

6 Gun Connector

7 Gun Securing Knob

8 Gun Connector Block

Loosen gun securing knob, and insert gun connector through Wire opening until it bottoms against block. Tighten knob. Close and latch door.

9 Water In Hose

Connect to Water In fitting on feeder (left-hand threads).

10 Water Out Hose

Connect to Water Out fitting on feeder (left-hand threads)

Close and latch door.

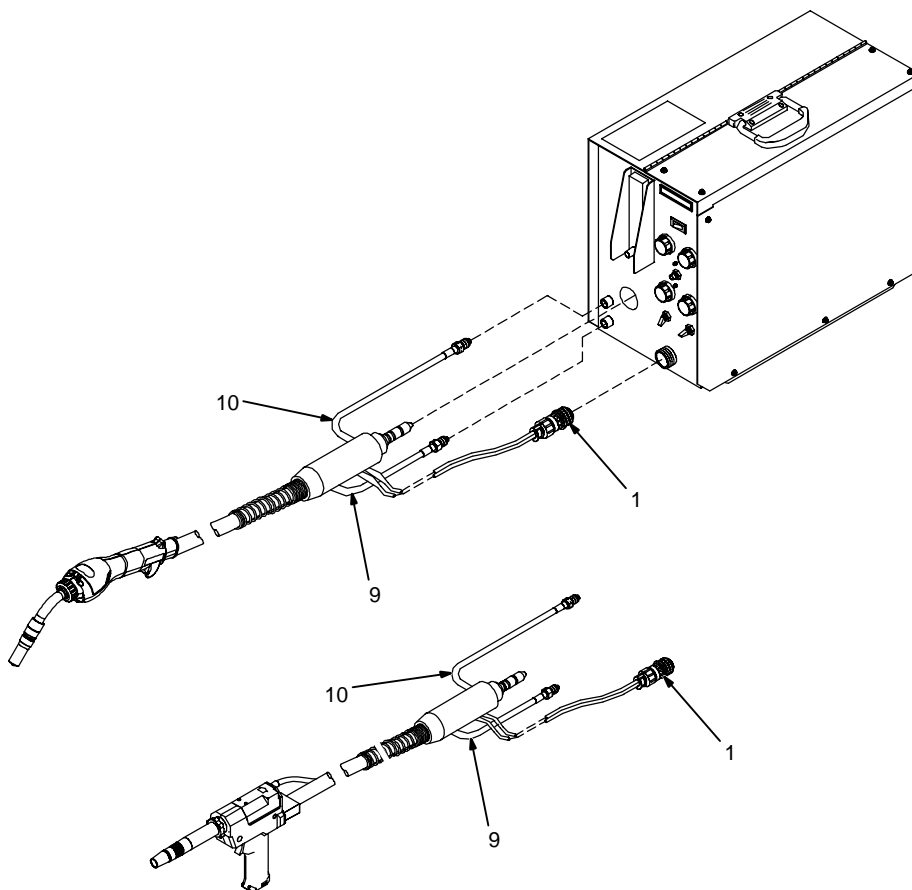

Tools Needed:

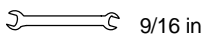

Ref. 801 577-A / 801 563-A / Ref. 151 666-B

4-6. 14-Pin Plug Information

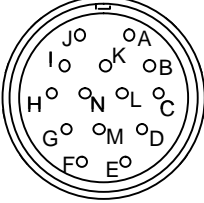
 REMOTE 14	Pin*	Pin Information
	A	24 volts ac with respect to socket G.
	B	Contact closure to A completes 24 volts ac contactor control circuit.
	G	Circuit common for 24 volts AC circuit.
	C	+10 volts dc output to remote control with respect to socket D.
	D	Remote control circuit common.
	E	0 to +10 volts dc input command signal from remote control with respect to socket D.
	H	Voltage feedback; 0 to +10 volts dc, 1 volt per 10 arc volts.
	F	Current feedback; 0 to +10 volts dc, 1 volt per 100 amperes.

*The remaining pins are not used.

4-7. (Optional) Voltage Sensing Lead Connections And CC/CV Jumper Plug Settings



Installing voltage sensing lead

- 1 Terminal Strip 2T
- 2 Strain Relief

Loosen screws of strain relief.

- 3 Voltage Sensing Lead

Route ring terminal end of lead through strain relief, and connect ring terminal to terminal A of terminal strip 2T. Tighten screws on strain relief.

- 4 Motor Speed Control Board PC1
- 5 Jumper Plug
- 6 Receptacle RC5

Unit is factory set for constant voltage (CV) welding. To set unit for constant current (CC) welding. Volt sensing lead kit must be installed in feeder. Volt sensing lead kit 209867



For constant voltage (CV) welding, place jumper plug in INT. position. Voltage sensing lead clamp does not need to be connected to workpiece.

For constant current (CC) welding, place plug in EXT. position. Connect clamp end of voltage sensing lead to workpiece.

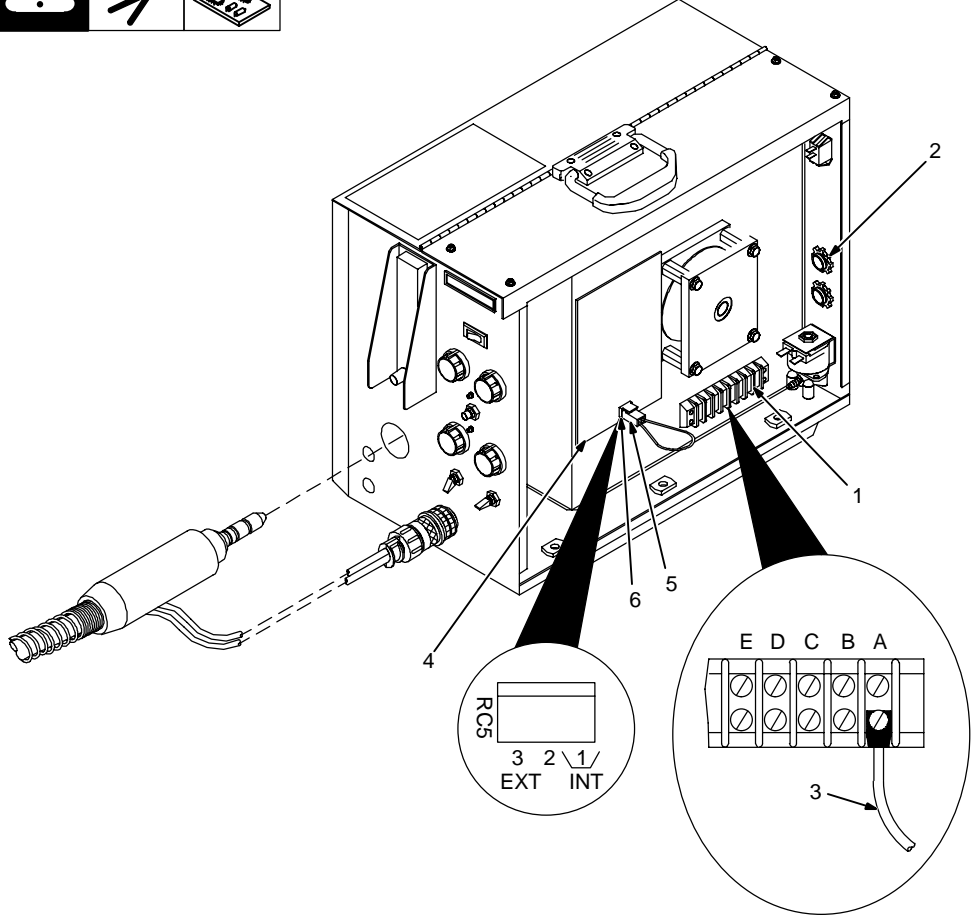
Reinstall right side panel.



Tools Needed:

 1/4 in

801 557-A

4-8. Meter Circuit Board Settings

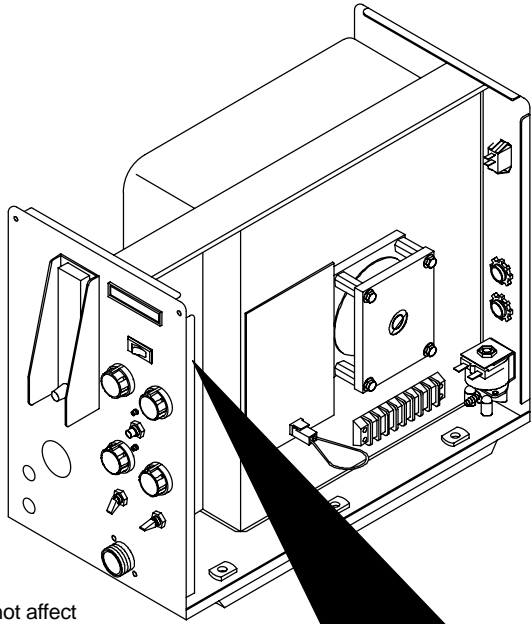

- 1 Meter Board PC2
- 2 DIP Switch S2

Set DIP switch S2 for type of welding power source, and desired wire feed speed display.

Reinstall hinged door and side panel.

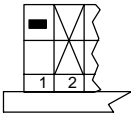

X Means switch position does not affect specified function.

■ Means switch must be in this position.

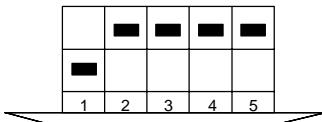

Switch settings from the factory.

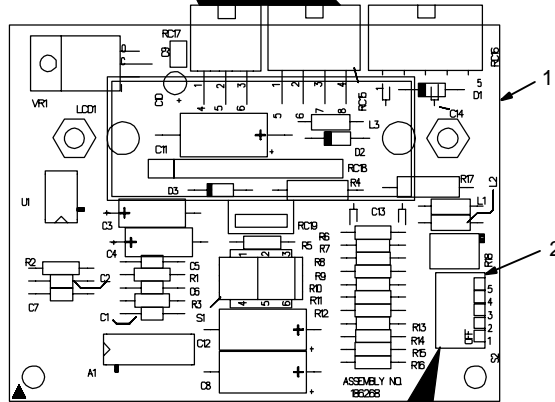

For sense lead, connect PLG51 to PLG50.

Before feeder can be used with a power source that does not support pins F and H, a voltage sensing lead must be installed in feeder. Volt sensing lead kit 209867. See section 4-7 for information regarding installation of voltage sensing lead.

For voltage feedback, connect PLG51 to PLG52.

Voltage Sensing Function

Arc Voltage Sensing Using Voltage Sensing Lead For Welding Power Source That Does Not Support Pins F And H

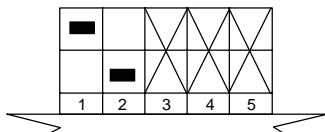

Or

Arc Voltage Sensing Using Feedback From Welding Power Source That Does Support Pins F And H

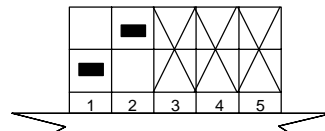

Digital Meter Display

Meters/Minute

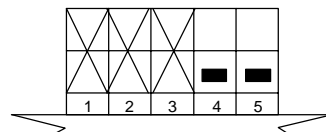

Or

Inches/Minute

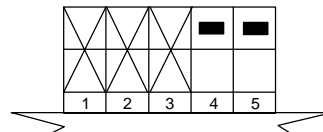

Tools Needed:

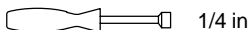

4-9. Adjusting Contact Tip Position



XR Edge Gun

- 1 Contact Tip
- 2 Nozzle

Adjusting barrel changes contact tip location from 1/16 in (1.6 mm) out beyond end of nozzle to 1/4 in (6.3 mm) inside nozzle.

- 3 Nozzle Adapter Lock Nut
- 4 Nozzle Adapter

To change contact tip location, loosen nozzle adapter lock nut, and turn nozzle adapter. Tighten nozzle adapter lock nut.

- 5 Jam Nut
- 6 Barrel

To change contact tip location, loosen jam nut, and turn barrel. Tighten jam nut.

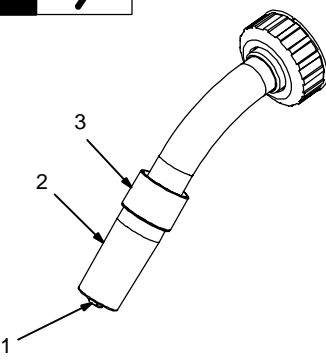

Water-Cooled Model

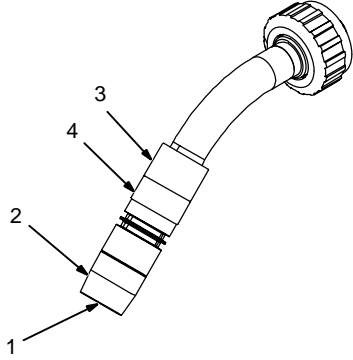

Air-Cooled Model

Pistol Grip Gun

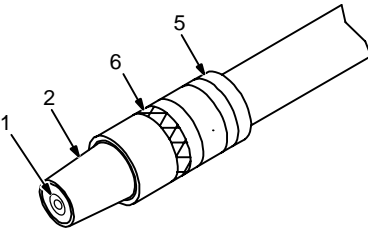

Water-Cooled Model

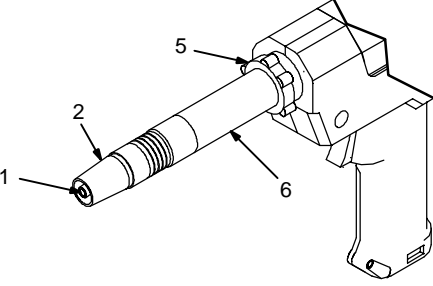

Air-Cooled Model

Ref. 801 556 / 150 434 / Ref. 150 431 / Ref. 151 666-A

4-10. Opening Top Cover Of XR-Edge Gun



- 1 Top Cover

Squeeze sides of cover to release clips and lift up as shown.

To close cover, pivot cover closed on gun, and push cover down until clips lock tight.

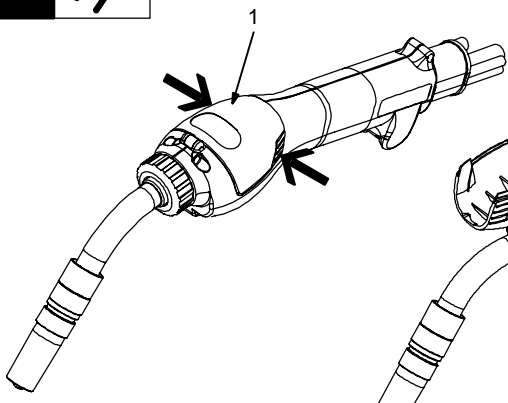

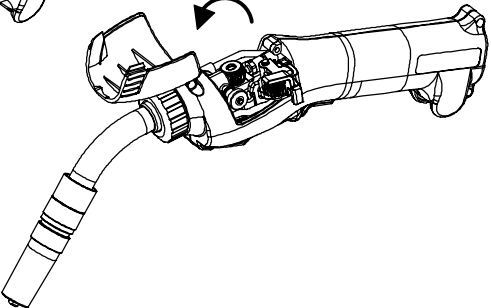

Ref. 801 556

4-11. Removing Top Cover Of Pistol Grip Gun

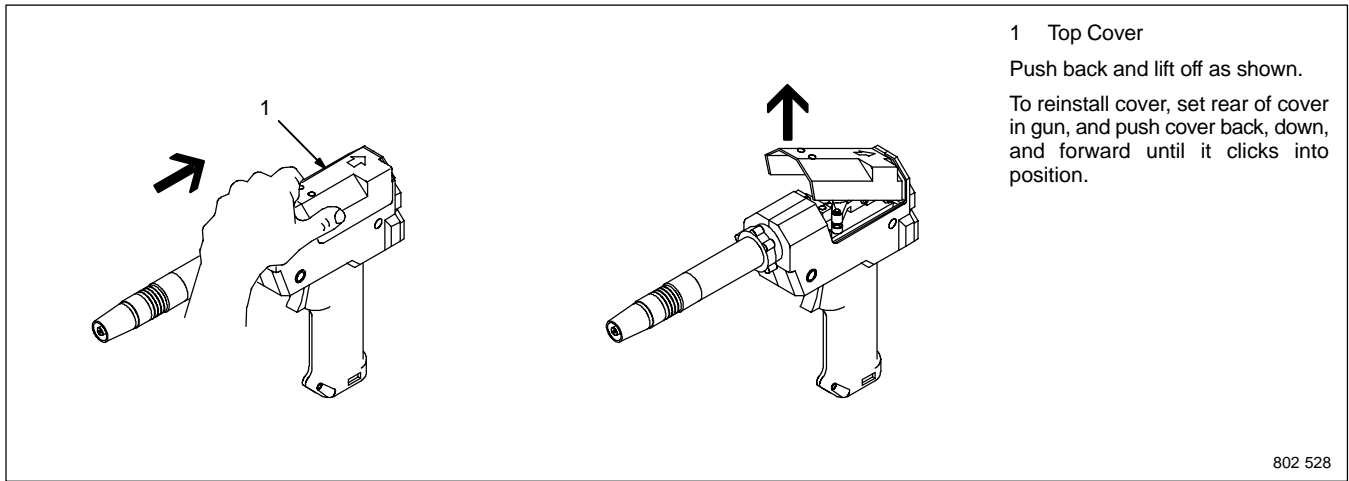

4-12. Installing Wire Spool

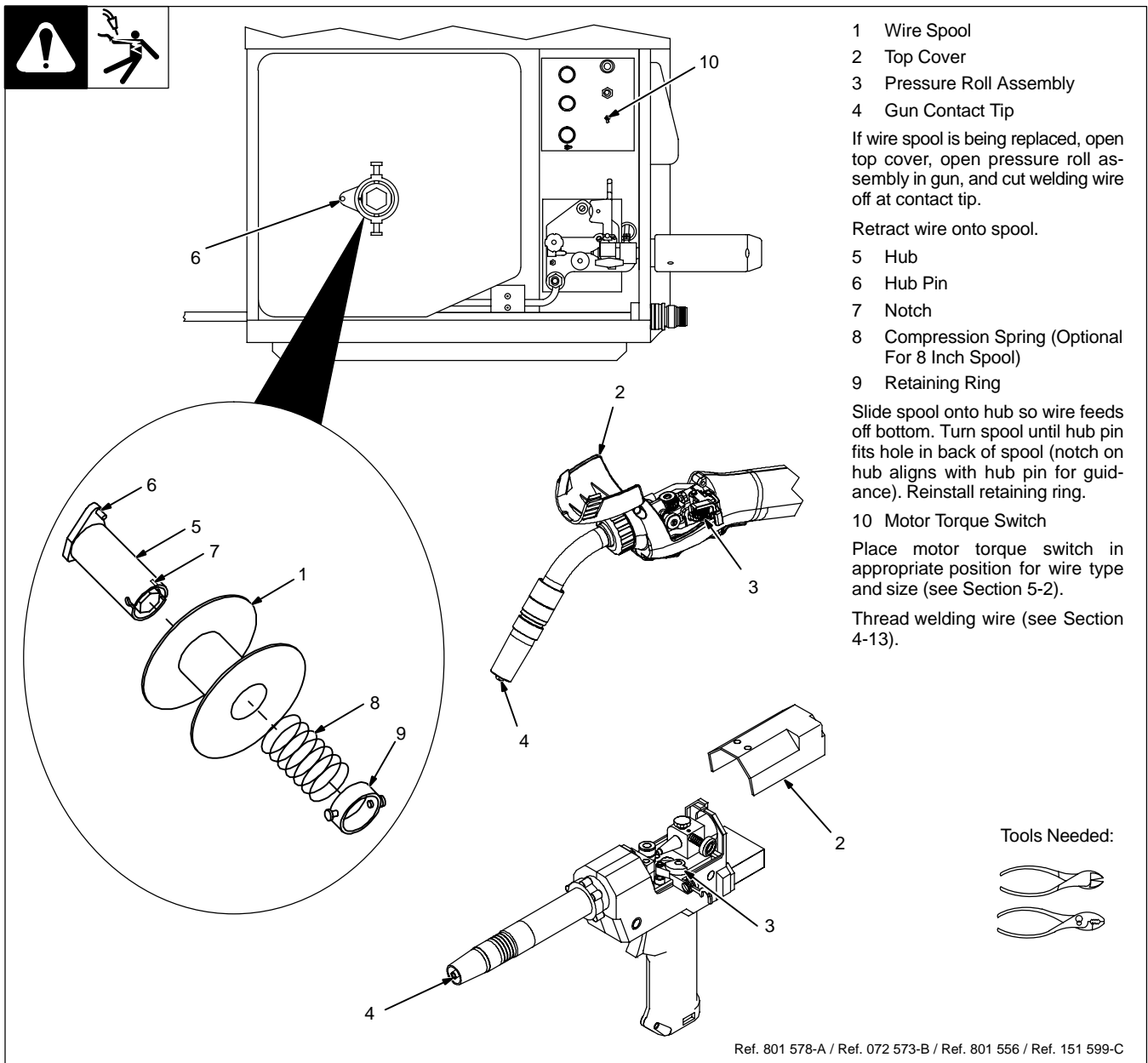

Tools Needed:

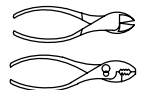

4-13. Threading Welding Wire Through Feeder

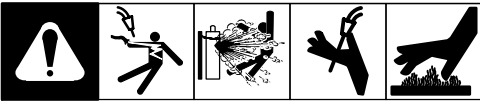

Tools Needed:

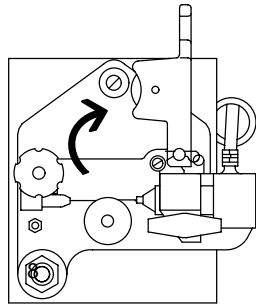

Open tension arm.

Hold wire tightly to keep it from unraveling.

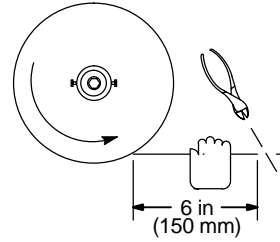

Pull and hold wire; cut off end.

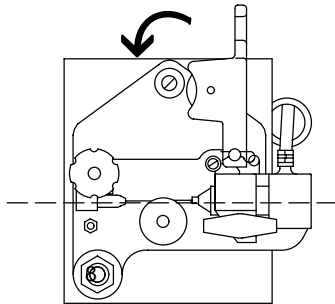

Proceed to Section 4-14.

Thread wire thru inlet guide, along drive roll groove, and into wire conduit. Close tension arm. **Adjust tension as follows:** grasp spool with one hand, press Jog switch, and turn thumb nut clockwise until motor stalls when Jog switch is pressed. Back thumb nut off slightly.

Ref. 802 193-A

4-14. Threading Welding Wire Through Gun



Refer to Section 4-13 for instructions on feeding wire through feeder.

For XR-Edge Gun:

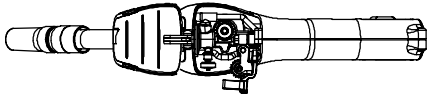

⚠ Welding wire is electrically live when gun trigger is used to jog wire.

☞ Turn OFF coolant supply before removing head tube on water-cooled gun.

Lay gun cable out straight. Open top cover, and open pressure roll assembly. Remove head tube from gun. Press Jog switch until about 2 in (51 mm) of wire is sticking out front of gun. Insert wire into head tube liner and secure head tube to gun.

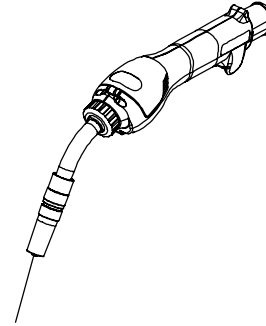
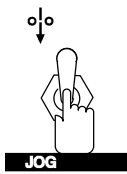

Close top cover on gun. Press Jog switch until about 6 in (152 mm) of wire is sticking out end of contact tip. See final pressure adjustment at bottom of page.

For Pistol-Grip Gun:

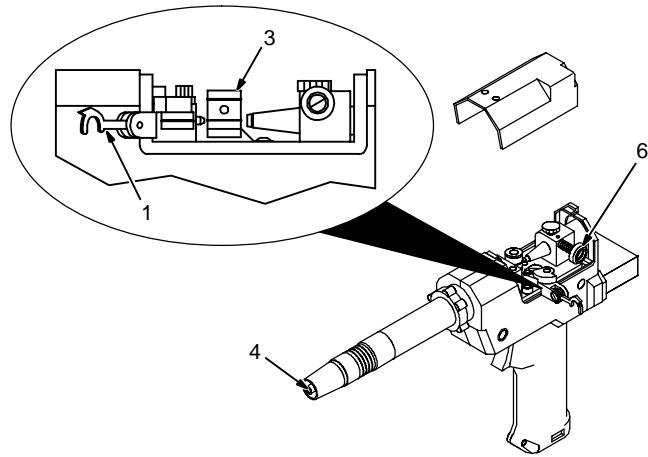
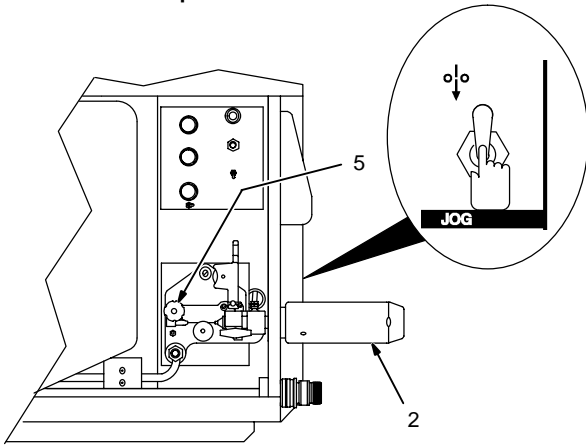

☞ Turn OFF coolant supply before removing head tube on water-cooled gun.

1 Pressure Roll Assembly

Lift arm and open pressure roll assembly.

2 Cable Assembly

Lay cable assembly out straight.

Push Jog switch up to feed wire through cable assembly.

3 Drive Roll

For wire sizes .035 in (0.9 mm) and smaller use small

groove, and .047 in (1.2 mm) and 1/16 in (1.6 mm) use large groove.

4 Contact Tip

Manually thread wire along drive roll groove and out contact tip 2 in (51 mm). Close pressure roll assembly.

5 Tension Thumbnut

6 Pressure Adjustment Knob

7 Final Pressure Adjustment

See procedure at bottom of page. Reinstall gun cover.

For Both Guns:

☞ Procedure is the same for pistol-grip gun.

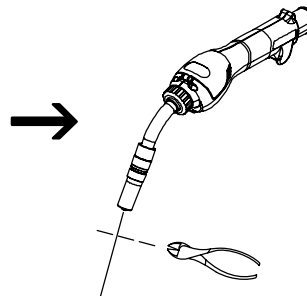
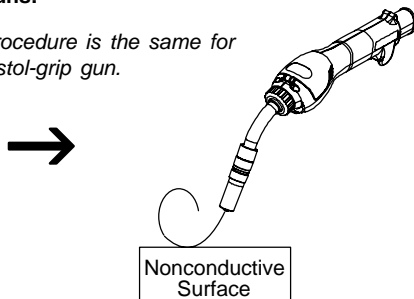

Tools Needed:



Feed wire to check drive roll pressure. If necessary, slightly tighten thumb nut inside gun.

Cut off wire. Close and latch wire feeder door.

4-15. Adjusting Wire Feed Starting Speed

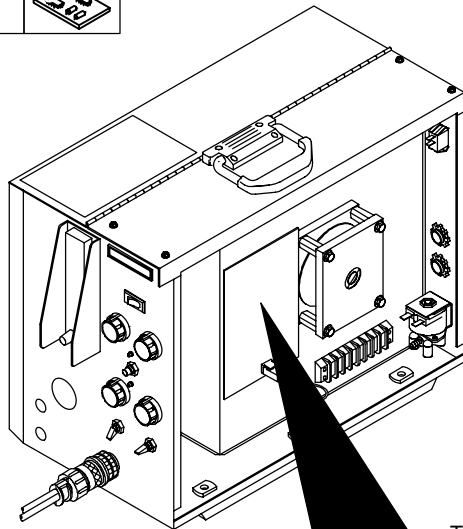

To adjust wire feed starting speed, proceed as follows:

- 1 Motor Speed Control Board PC1
- 2 Motor Start Control Potentiometer R3

Remove protective white rubber cap before making adjustment. Adjust potentiometer using a small nonconductive screwdriver. Turn potentiometer clockwise to increase time it takes the motor to ramp up to speed.

Reinstall side panel.

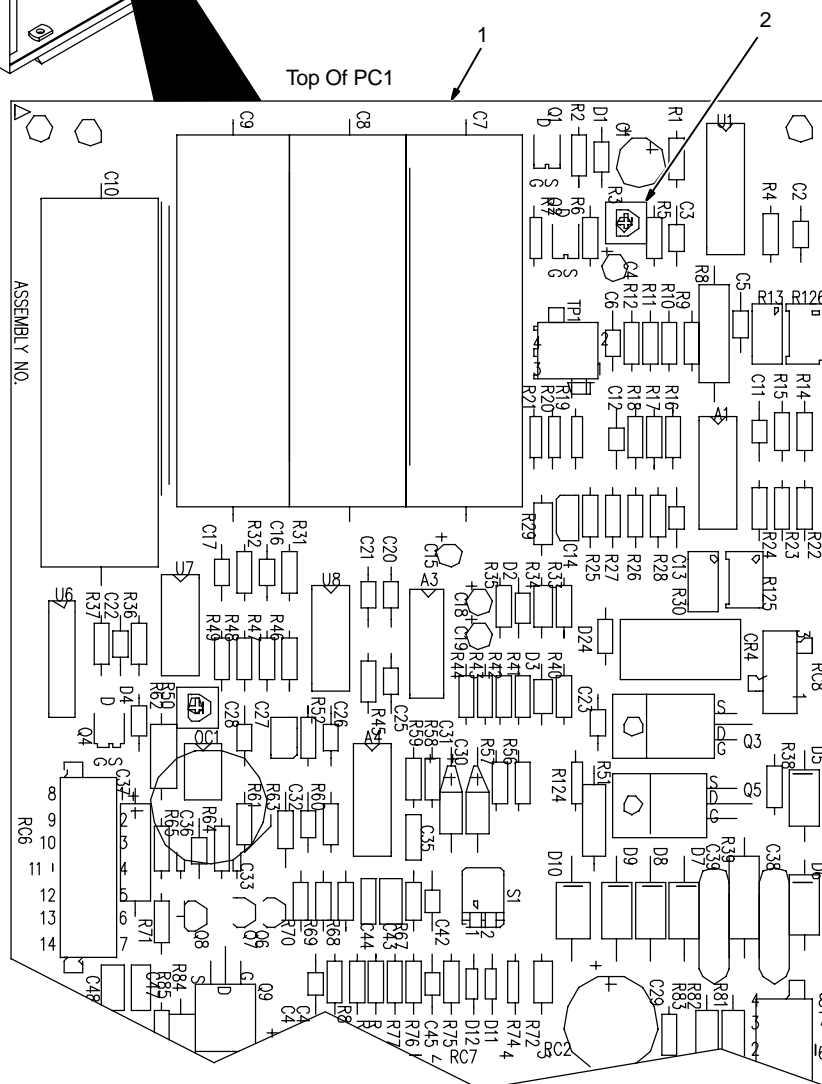

Tools Needed:

Nonconductive

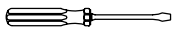

1/4 in

Ref. 801 557 / 197 716

4-16. Setting Switches For Prewflow And Postflow

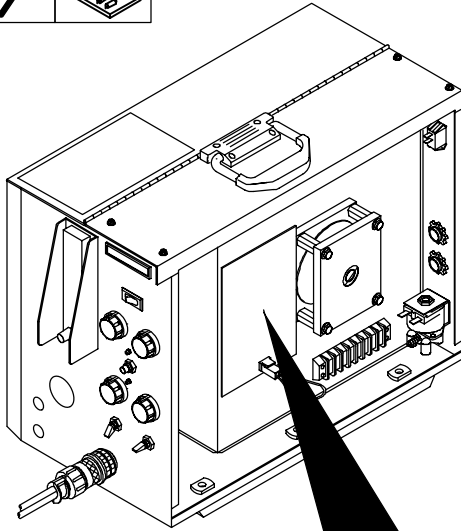

Top Of PC1

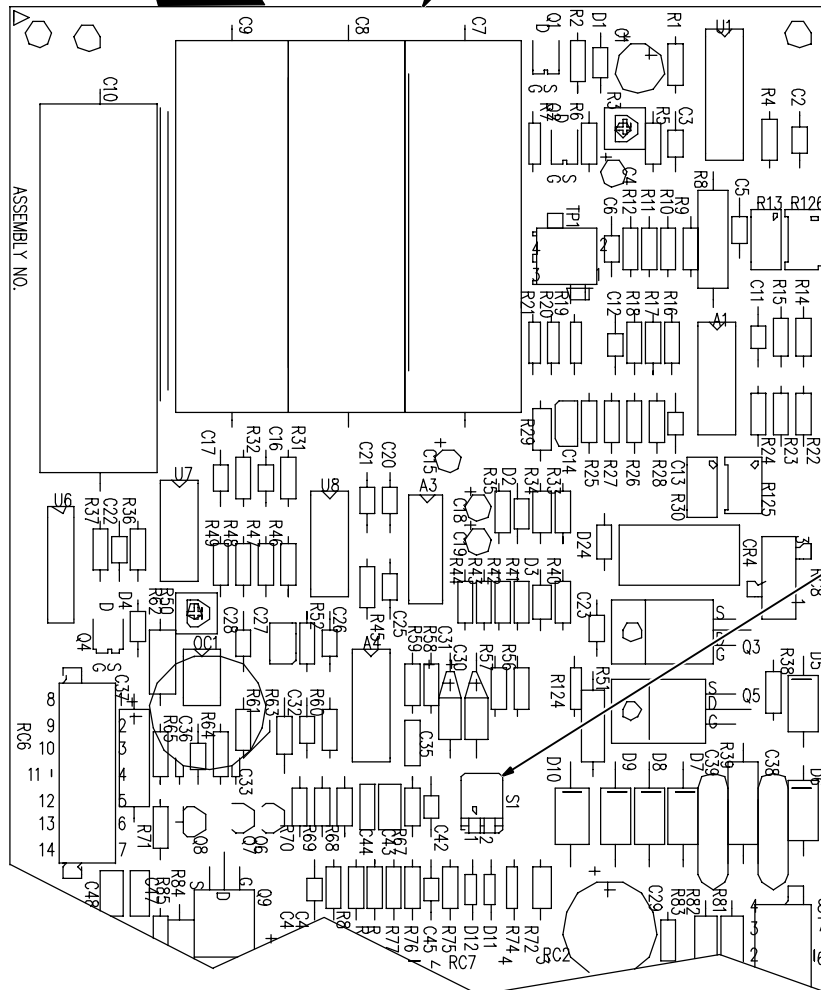

Tools Needed:

Nonconductive



1/4 in

Unit arrives from the factory with preflow Off and postflow turned On.

To set switches for preflow and postflow, proceed as follows:

- 1 Motor Speed Control Board PC1
- 2 DIP Switch S1

Preflow and postflow have pre-set time values and cannot be changed.

To provide a 0.25 second preflow time, use a small nonconductive screwdriver to set switch S1-1 in the up position. To turn preflow time off, set S1-1 in the down position.

To provide a 0.5 second postflow time, use a small nonconductive screwdriver to set switch S1-2 in the up position. To turn postflow time off, set S1-2 in the down position.

Reinstall side panel.

4-17. Adjusting Trigger Hold Actuation Time

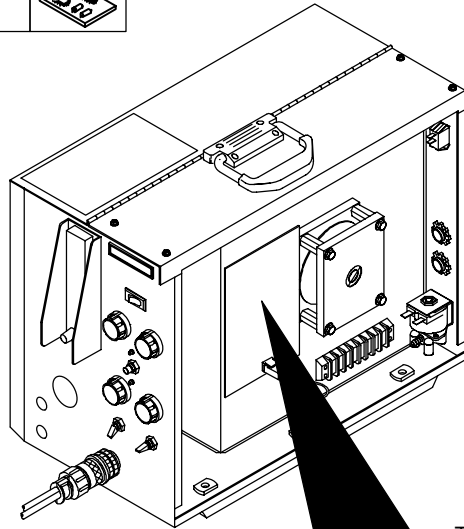

Top Of PC1

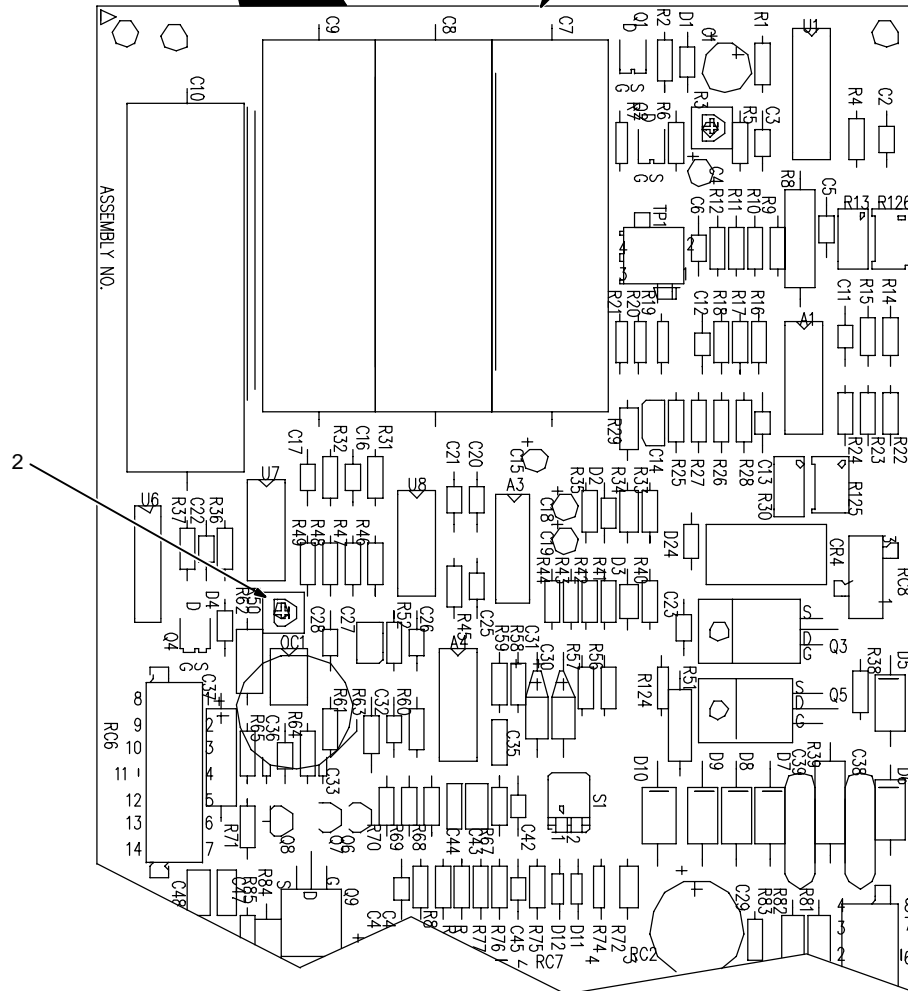

Tools Needed:

Nonconductive

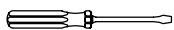

1/4 in

To adjust trigger hold actuation time, proceed as follows:

- 1 Motor Speed Control Board PC1
- 2 Potentiometer R50

☞ Trigger hold actuation time range is from 0 to 4 seconds.

To decrease trigger hold actuation time, use a small nonconductive screwdriver and rotate potentiometer clockwise; to increase actuation time, rotate potentiometer counterclockwise.

Reinstall side panel.

Ref. 801 557 / 197 716

SECTION 5 – OPERATION

5-1. Controls

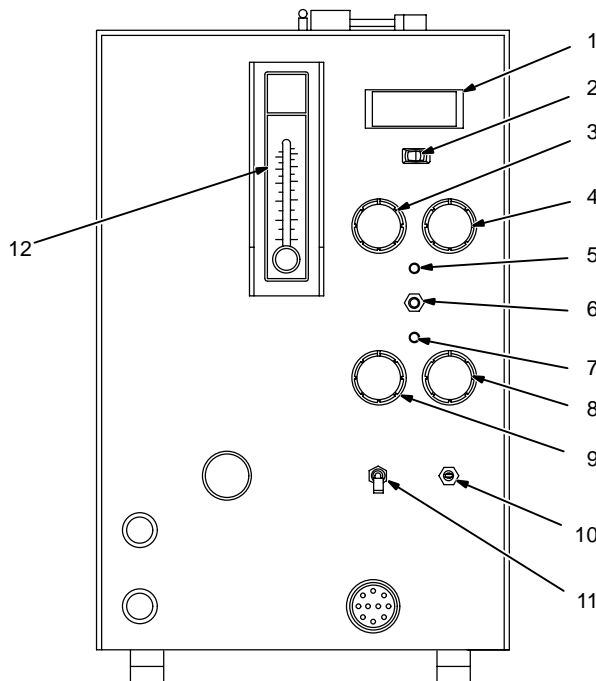

801 554

1 Voltage/Wire Speed Meter

2 Voltage/Wire Speed Switch

When switch is in Voltage position, and operator is welding, meter displays arc voltage. Cable resistance and poor connections may cause displayed voltage to vary slightly from actual voltage at welding arc.

When switch is in Wire Speed position and operator is welding, meter displays preset wire speed in inches per minute. This wire speed is the combined settings of the Weld Speed Control on unit and Wire Speed Control on gun.

During run-in portion of weld cycle, meter displays run-in speed as selected on Run-In Speed control on feeder.

When welding Direct Current Electrode Negative (DCEN), meter does not display accurate output voltages; however, meter displays accurate wire speed values.

3 Remote Voltage Control (Optional)

Use control to adjust arc voltage at the wire feeder.

The scale around the control is marked in percent.

4 Wire Speed Control

Use control to set wire feed speed after arc initiation.

 *The gun wire feed speed control adjusts wire speed from minimum to maximum setting on Wire Speed Control.*

The scale around the control is percent of full range, not wire speed.

5 Schedule A Indicator LED

LED illuminates when Schedule A is active.

6 Press To Set Push Button

Use push button to set wire speed for Schedule B.

7 Schedule B Indicator LED

LED illuminates when Schedule B is active.

8 Wire Speed B Control (Optional)

Use control to set wire feed speed for a schedule B welding operation.

 *A dual schedule switch must be installed in unit to set wire speed B. There is no run-in speed setting for wire speed B.*

The scale around the control is percent of full range, not wire speed.

9 Remote Voltage B Control (Optional)

Use control to adjust arc voltage at the wire feeder for a schedule B welding operation.

The scale around the control is marked in percent.

10 Jog/Purge Switch

Push up to momentarily feed welding wire at speed set on Wire Speed control without energizing welding circuit or shielding gas valve.

Push down to momentarily energize gas valve to purge air from gun or adjust gas regulator.

11 Trigger Hold Switch

Push up to weld without holding gun trigger throughout the weld cycle.

To start weld, press gun trigger, and trigger hold will actuate after 3 seconds of weld time. To end weld, press and release gun trigger.

12 Flowmeter (Optional)

Use flowmeter to control shielding gas flow at the feeder. The scale on the flowmeter is in cubic feet per hour (CFH). Read gas flow at the widest part of the float in the meter. Rotate valve to change gas flow as necessary.

A regulator is still required on shielding gas supply with this option.

5-2. Internal Controls

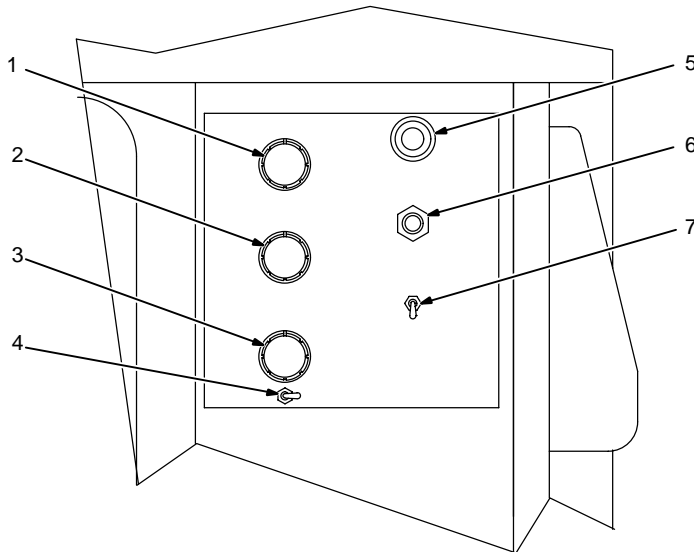

Open left side door.

1 Run-In Speed Control

Use this control to set run-in wire feed speed before arc initiation.

After arc initiation, weld wire feed speed is controlled by the wire speed setting on the welding gun (see Section 5-3).

The scale around the run-in speed control is a percent of weld wire feed speed. As a general rule, set run-in speed lower than welding wire feed speed.

 *The gun wire feed speed control adjusts wire speed from minimum to maximum setting on Wire Speed Control.*

Set control at 0 (zero) for scratch start.

2 Burnback Time Control (Optional)

Use control to adjust time (up to 0.25 seconds) that the welding wire is electrically energized after the wire stops feeding.

If welding wire sticks in the weld puddle, increase burnback time. If wire burns back into the gun contact tip, decrease burnback time.

The scale around the control is marked in fractions of a second.

3 Spot Time Control (Optional)

Use control to set spot weld time. Welding wire feeds at speed selected on the gun Wire Speed Control. Spot time starts at arc initiation.

Rotating switch fully counterclockwise until it clicks selects an untimed continuous weld, all other positions will provide various timed spot welds.

The scale around the control is marked in seconds.

4 Time Range Switch

Use switch to select spot weld time range.

5 Fuse F1

See Section 6-13.

6 Circuit Breaker CB1

See Section 6-13.

7 Motor Torque Switch

Use switch to select the force used to push wire. The up position is for high force, or torque. The down position is for low force, or torque.

Use Low position for .030 wire size and High position for all other wire sizes.

Close and latch door.

Ref. 801 578

5-3. Gun Controls

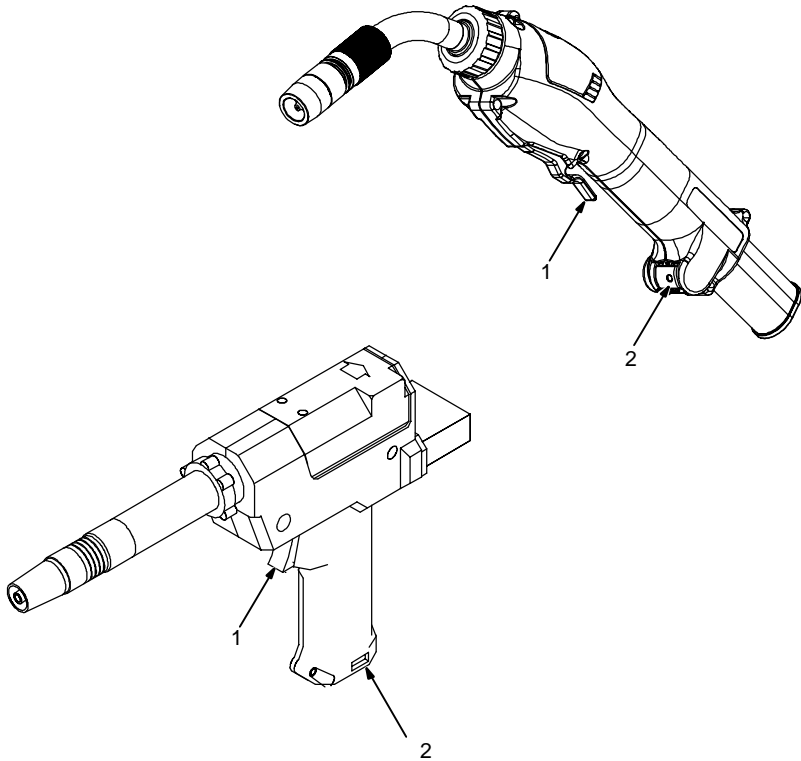

1 Trigger

Press trigger to energize welding power source contactor (if applicable), start shielding gas flow, and begin wire feed.

Switches inside the wire feeder can be set to provide timed shielding gas preflow and postflow when trigger is pressed and released (see Section 4-16). When this feature is turned Off, no preflow or postflow is provided for the welding operation.

2 Wire Speed Control

Use control to fine adjust wire feed speed set on wire feeder Weld Speed control. The numbers around the control are for reference only.

Ref. 151 666-A

5-4. Shielding Gas

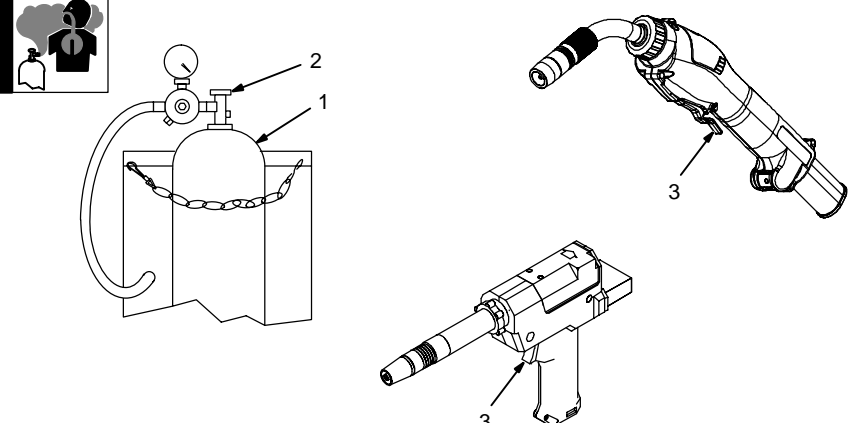

1 Shielding Gas Cylinder

2 Valve

3 Gun Trigger

Open valve on cylinder just before welding.

Gun trigger turns weld output and gas flow on and off (see Section 5-3).

Close valve on cylinder when finished welding.

sb5.1 6/92 – S-0621-C / Ref. 151 666-A

5-5. Coolant Supply For Water-Cooled Models Only

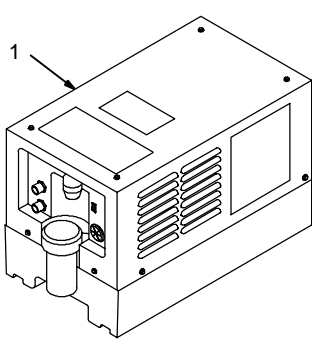

1 Coolant Supply

See Section 4-4 for coolant guidelines.

Turn On coolant supply before welding.

Turn Off coolant supply when finished welding.

Ref. 150 755-A

5-6. Sequence Of Gas Metal Arc Welding (GMAW) – Continuous Or Spot

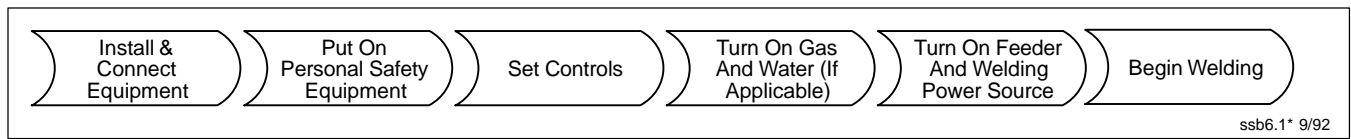

SECTION 6 – MAINTENANCE & TROUBLESHOOTING

				<p>▲ Disconnect power before maintaining.</p> <p style="text-align: right;"> <i>Maintain more often during severe conditions.</i></p>
<p> 4 To 6 Weeks</p>				
<p>Apply Conductive Grease To Drive Roll Screw (See Sections 6-2 And 6-7)</p>				
<p> 3 Months</p>				
		<p>Replace Damaged Or Unreadable Labels</p>	<p>Clean And Tighten Weld Terminals</p>	<p>Replace Damaged Gas Hose</p>
		<p>Repair Or Replace Cracked Cables And Cords</p>		
<p> 6 Months</p>				
<p>Blow Out Or Vacuum Inside</p>		<p>Clean Drive Rolls</p>		

6-1. Feeder Drive Assembly Maintenance

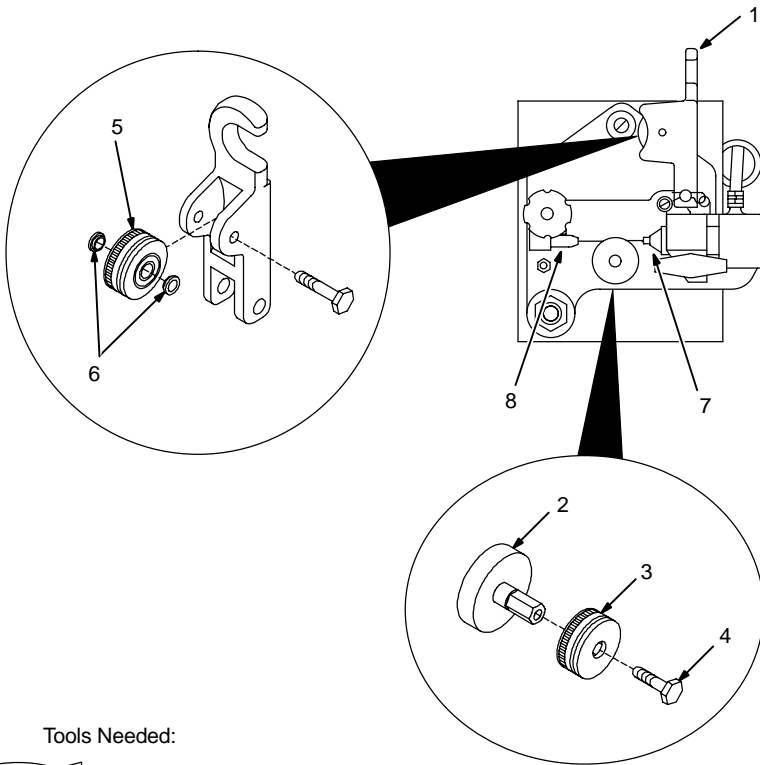
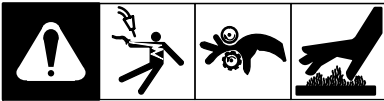

Tools Needed:

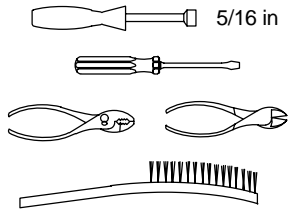

Retract wire onto spool.

- 1 Pressure Roll Assembly
- 2 Drive Motor Shaft
- 3 Drive Roll
- 4 Screw

Use wire brush to clean drive roll.

- 5 Drive Roll Idler
- 6 Shoulder Washers

Use wire brush to clean idler.

- 7 Outlet Guide
- 8 Wire Inlet Guide

Pull guide toward rear of feeder to remove. Install new guide.

Thread welding wire and adjust drive roll pressure, if necessary (see Section 4-13).

Drive roll and idler are available for the following wire size ranges:

- .030-.035 wire size
- .047 wire size
- .062 wire size

When changing wire size, change control box drive roll and idler, gun pressure roll and drive roll (see Section 6-2 for XR-Edge guns; see Sections 6-7 and 6-8 for pistol-grip guns), and gun liner (see Section 6-4 for XR-Edge guns; see Section 6-9 for pistol-grip guns).

802 193-A

6-2. Gun Drive Assembly Maintenance For An XR-Edge Gun

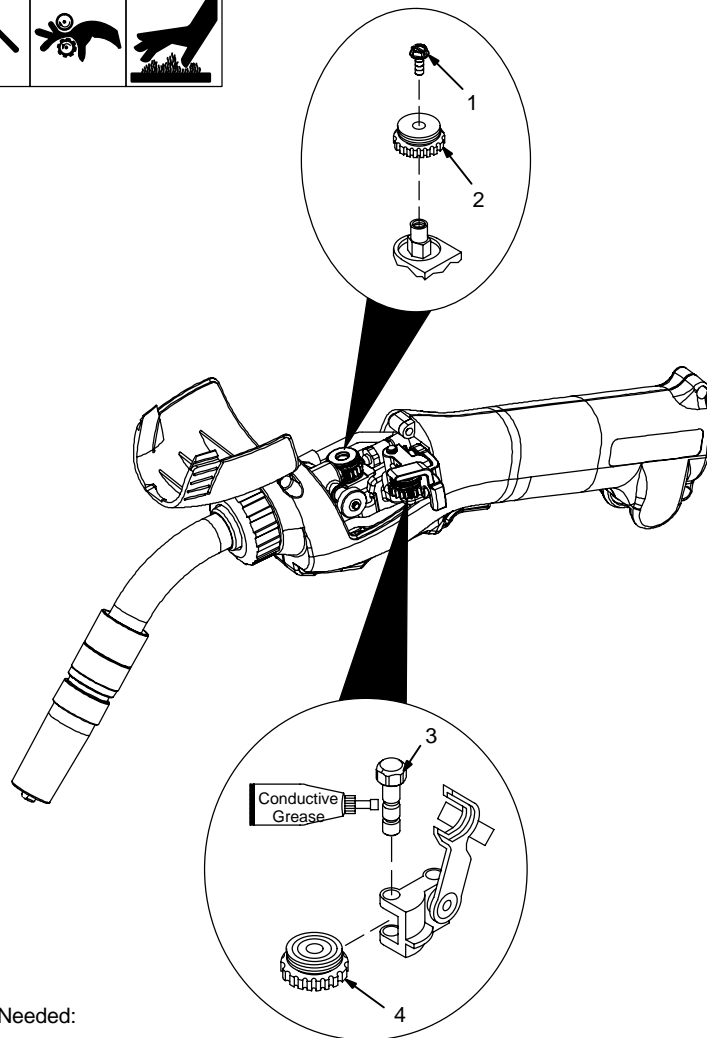
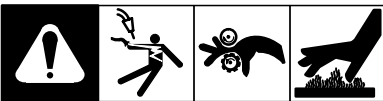

Tools Needed:

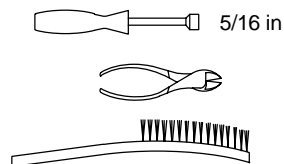

Retract wire onto spool.

- 1 Screw
- 2 Drive Roll

Use wire brush to clean drive roll. Install drive roll with hex opening down toward shaft hex, and secure with screw.

 Apply *conductive grease* to drive roll post every 4 to 6 weeks.

- 3 Post
- 4 Pressure Roll w/Bearing

Use wire brush to clean pressure roll. Install pressure roll so that gear teeth mesh with drive roll gear teeth, and secure with screw.

If changing drive roll in feeder, see Section 6-1.

Thread welding wire through gun. Close and secure pressure roll assembly. Adjust drive roll pressure, if necessary (see Section 4-13).

Drive roll and pressure roll are available for the following wire sizes:

- .030 wire size
- .035 wire size
- .047 wire size
- .062 wire size

When changing wire size, change control box drive roll and idler (see Section 6-1), gun pressure roll and drive roll, and gun liner (see Section 6-4 and 6-9).

Close top cover.

Ref. 801 556

6-3. Removing Contact Tip Adapter In XR-Edge Guns

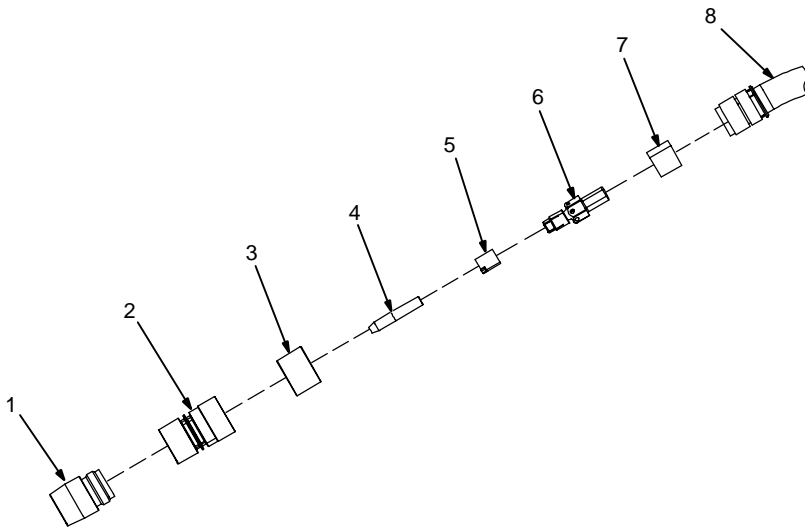
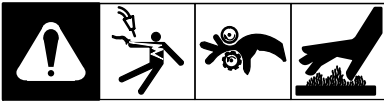

- 1 Nozzle
- 2 Adapter Nozzle
- 3 Nozzle Adapter Locking Nut

Loosen locking nut to remove nozzle and adapter nozzle.

- 4 Contact Tip
- 5 Collet Nut
- 6 Quick Change Contact Tip Adapter

Remove contact tip from contact tip adapter.

- 7 Insulated Sleeve
- 8 Head Tube

Install insulated sleeve, then install and tighten new adapter into head tube. Reinstall contact tip, collet nut, adapter nozzle, and nozzle.

Tools Needed:

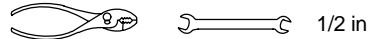

Ref. 802 253

6-4. Replacing Head Tube Liner In XR-Edge Guns

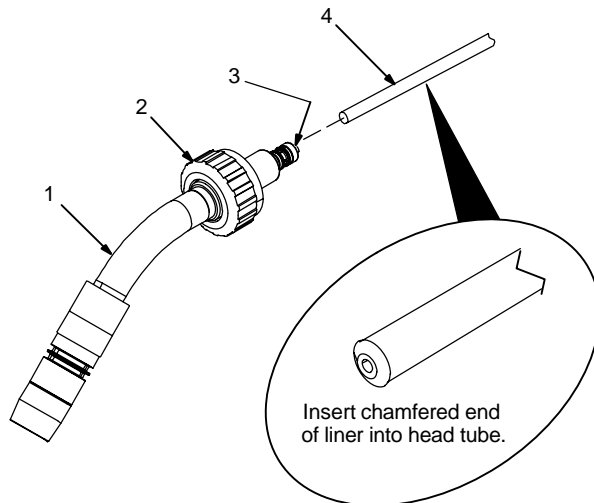
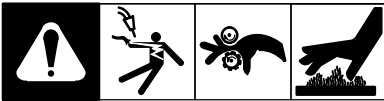

☞ Turn OFF coolant supply before removing head tube on water-cooled gun.

Head tube liner is available for the following wire size ranges:

.030-.035 wire size

.047-1/16 wire size

When changing wire size, change control box drive roll and idler (see Section 6-1), gun pressure roll and drive roll (see Sections 6-2 and 6-7), and gun liner.

- 1 Head Tube
- 2 Head Tube Nut

Loosen head tube nut and remove head tube from gun.

- 3 O-Ring
- 4 Liner

Pull liner out of head tube. Be sure o-ring stays in place in groove. Replace o-ring if necessary. If o-ring is replaced, o-ring must be installed before liner is inserted.

Insert new liner into head tube and reinstall head tube onto gun.

☞ Be sure head tube nut is securely tightened before operating gun. If head tube nut is not adequately tightened, unwanted arcing may occur between head tube and gun housing.

Ref. 802 328

6-5. Replacing Gun Cable Liner

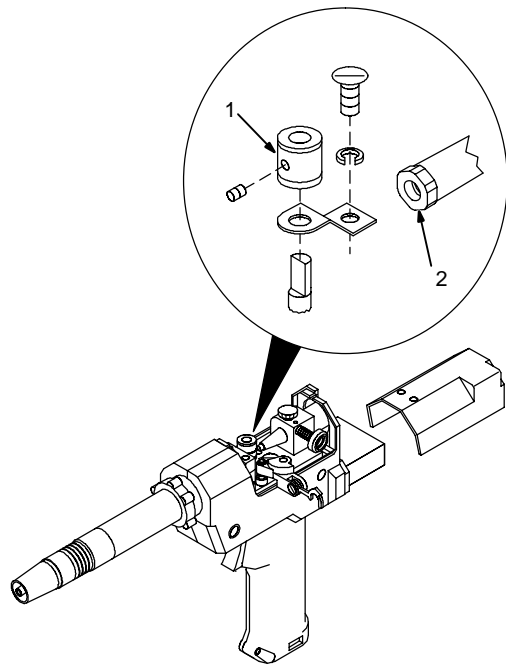

Pistol Grip Gun

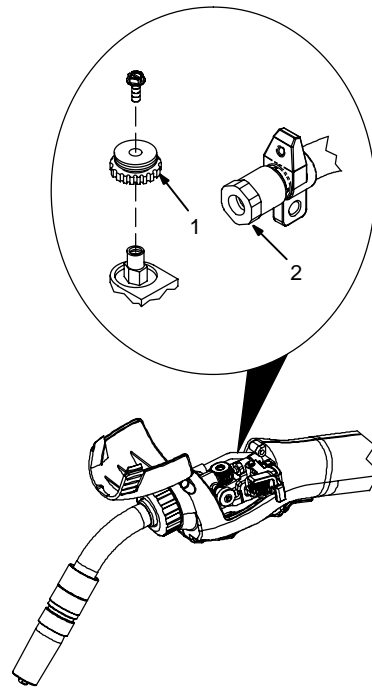

XR-Edge Gun

▲ Turn Off welding power source and wire feeder.

1 Drive Roll

2 Collet Nut

Lay gun cable out straight. Remove drive roll on gun and loosen collet nut on liner tube assembly.

3 Gun Connector

Remove inlet guide from gun connector, and remove old liner.

4 New Liner

Insert split end of new liner into gun connector and continue feeding liner through cable assembly until liner is through collet and all of split portion is visible.

Cut off split portion of liner. Position liner as close as possible to drive rolls without touching them. Tighten collet nut. Reinstall inlet guide at gun connector and tighten onto liner.

Cut liner as close as possible to control (push motor) drive rolls.

See Section 4-14 for instructions on rethreading wire.

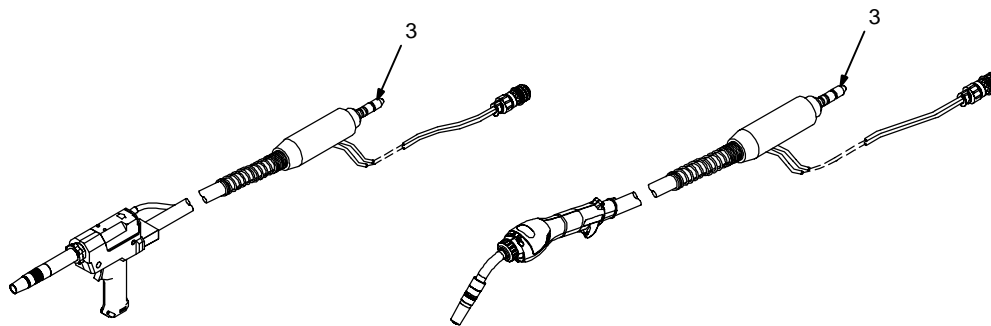

6-6. Changing Gun Contact Tip

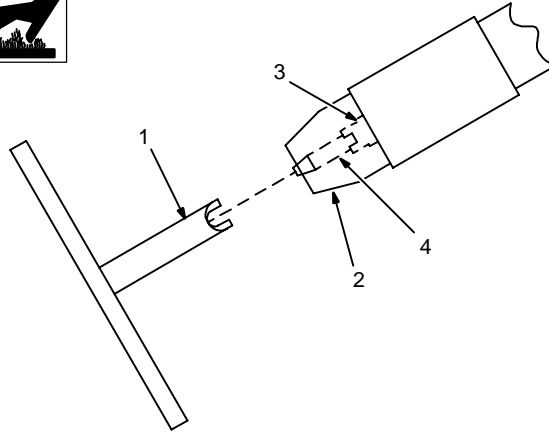

- 1 Contact Tip Wrench
- 2 Nozzle

Insert wrench into nozzle over contact tip.

- 3 Compression Nut
- 4 Contact Tip

Loosen nut. Pull out contact tip.

Install new contact tip.

Tighten nut just until contact tip is secure. Overtightening nut will damage adapter.

150 437

6-7. Replacing Or Cleaning Gun Drive Roll In Pistol-Grip Guns

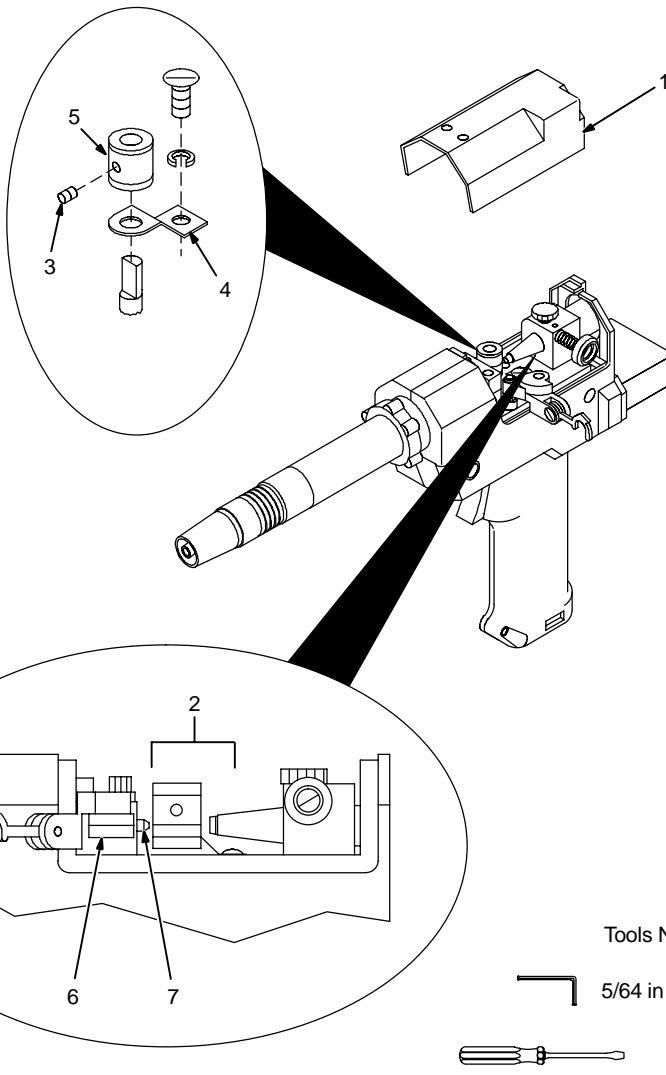

Turn Off wire feeder and welding power source.

- 1 Top Cover
- 2 Pressure Roll Assembly

Cut off wire where it enters pressure roll assembly area.

- 3 Setscrew
- 4 Current Pick-Up Tab

This tab helps prevent burnback caused by welding arcs inside the contact tip. This tab may be removed to provide an insulated drive roll. (If tab is removed, a smaller diameter contact tip is recommended. See options in Parts List.) Lightly grease top of tab before reinstalling.

- 5 Drive Roll

Use wire brush to clean drive roll. Install drive roll with desired groove down, and turn drive roll so one setscrew faces flat side of shaft.

- 6 Bearing
- 7 Liner

Line up drive roll groove with bearing groove and liner opening. Tighten setscrews.

If changing drive roll in feeder, see Section 6-1.

Thread welding wire through gun, and adjust drive roll pressure, if necessary (see Section 4-14). Close and secure pressure roll assembly. Reinstall top cover.

Tools Needed:

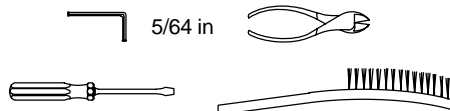

Ref. 151 599-C

6-8. Replacing Or Cleaning Gun Drive Roll Bearing In Pistol-Grip Guns

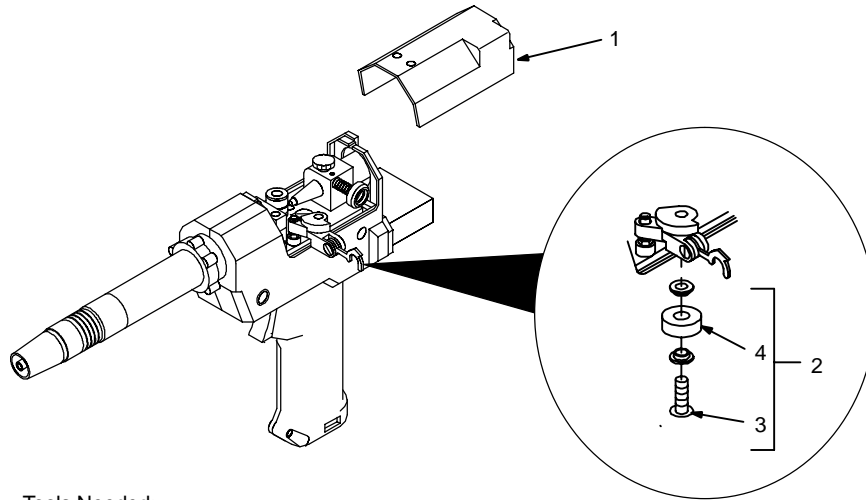
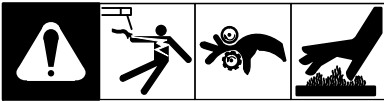

Turn Off wire feeder and welding power source.

- 1 Top Cover
- 2 Pressure Roll Assembly
- 3 Screw
- 4 Pressure Roll

Remove as shown.

Use a wire brush to clean bearing. Reinstall with washers, and tighten screw.

Close pressure roll assembly. Reinstall top cover.

Tools Needed:

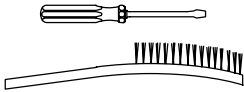

Ref. 151 599-C

6-9. Replacing Head Tube Liner In Pistol-Grip Guns

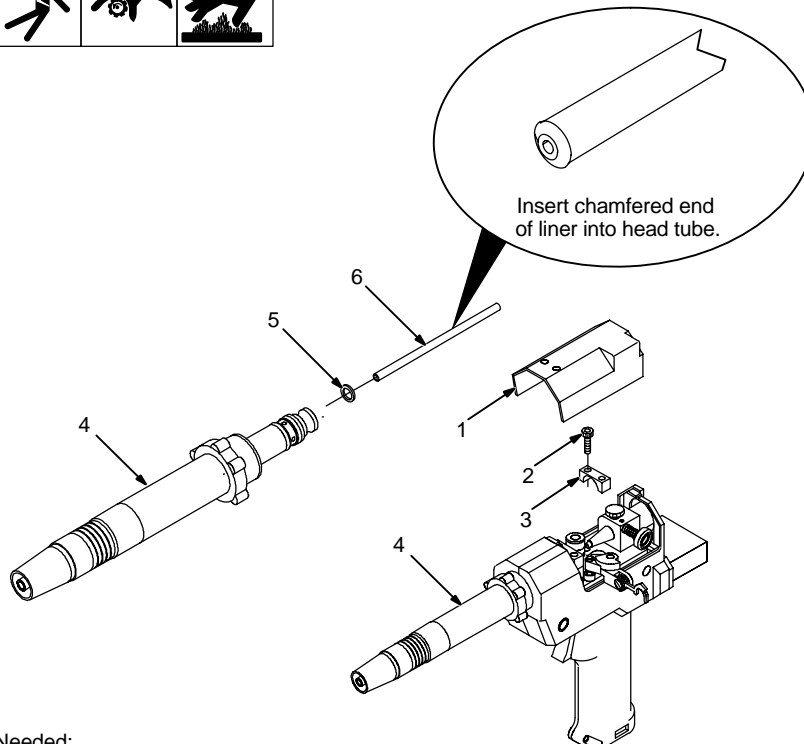

☞ Turn OFF coolant supply before removing head tube on water-cooled gun.

Head tube liner is available for the following wire size ranges:

.030-.040 wire size

.047-.062 wire size

When changing wire size, change control box drive roll and idler (see Section 6-1), gun drive roll (see Sections 6-2 and 6-7), and gun head tube liner.

- 1 Cover
- 2 Screw
- 3 Clamp

Loosen clamp screws and remove clamp.

4 Head Tube

Remove head tube from gun.

5 O-Ring

6 Liner

Pull liner and o-ring out of head tube.

Insert new o-ring and liner (o-ring first) into head tube and reinstall head tube onto gun.

Tool Needed:



Ref. 143 117-E / Ref. 151 599

6-10. Removing Contact Tip Adapter In Air-Cooled Pistol-Grip Guns

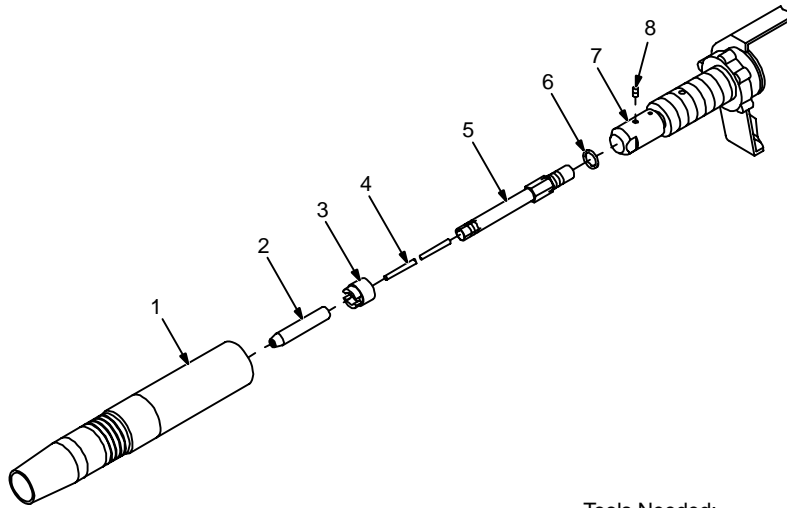

Tools Needed:

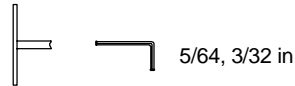

Turn Off wire feeder and welding power source.

1 Nozzle Extension

Remove as shown.

2 Contact Tip

3 Compression Nut

To remove, see Section 6-6.

4 Liner

5 Contact Tip Adapter

6 Washer

7 Extension Adapter

8 Setscrew

Loosen setscrew and remove adapter. Install new adapter and tighten setscrew. Reinstall liner, contact tip, compression nut, and nozzle.

150 430-B

6-11. Removing Contact Tip Adapter In Water-Cooled Pistol-Grip Guns

WARNING

WATER IN GUN PARTS can cause ELECTRIC SHOCK and can lower weld quality.

- Turn Off welding power source and water supply before working on gun. Stop engine on welding generators.
- Always point gun downward when removing water-cooled barrel to keep water out of gun parts.
- Wipe gun dry before putting it back together.

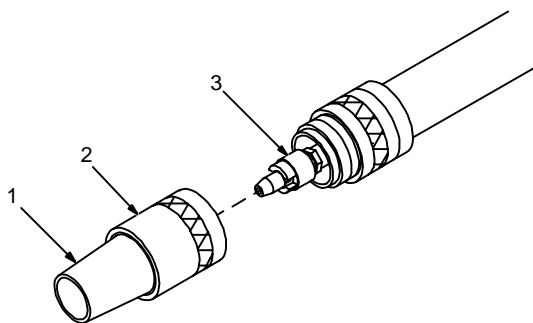

Turn Off weld control and welding power source.

1 Nozzle

2 Nozzle Adapter

Remove as shown.

3 Contact Tip Adapter

Use supplied 3/32 in allen wrench to remove adapter.

Coat new adapter with threadlocking compound (such as Loctite No. 242), and install.

150 431

6-12. Replacing Hub Assembly

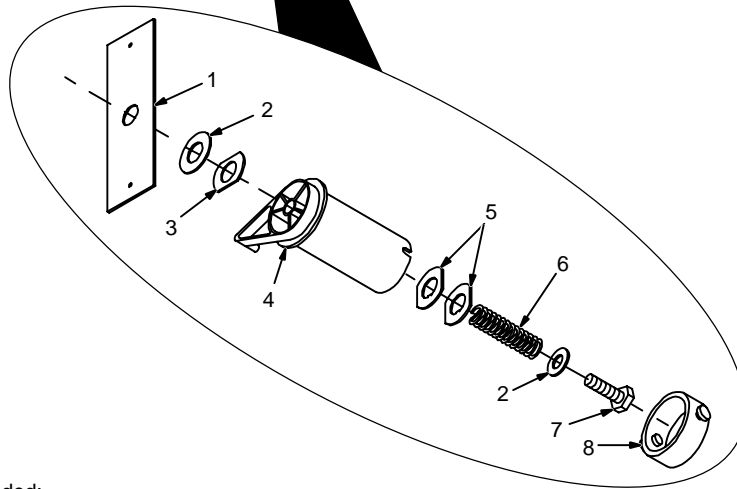
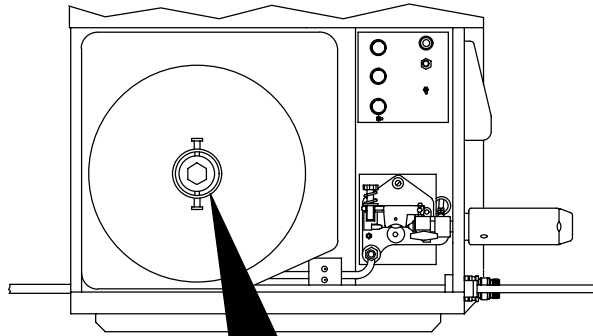

Remove gun top cover and release pressure arm (see Sections 4-10 and 4-11).

Retract wire onto spool and remove spool. Take hub apart as shown.

- 1 Metal Brake Washer
- 2 Flat Washer
- 3 Brake Washer
- 4 Hub
- 5 Keyed Washer
- 6 Spring
- 7 Cap Screw
- 8 Retaining Ring

Replace broken or worn parts and slide parts onto shaft as shown.

Adjust hub tension and thread welding wire. Close and latch door.

Close gun pressure roll assembly and reinstall gun cover.

Tools Needed:

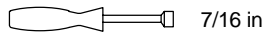

801 577 / Ref. 143 223-A

6-13. Overload Protection

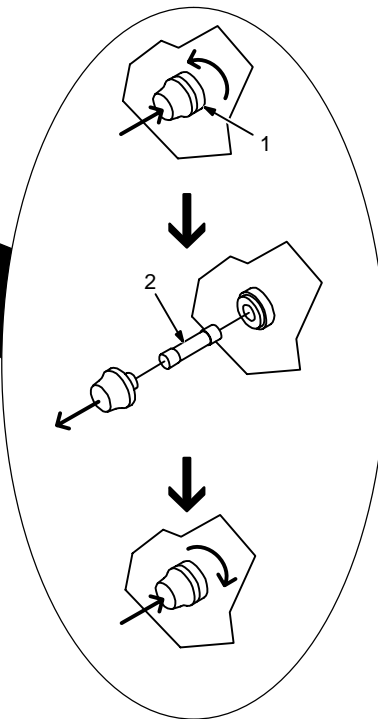
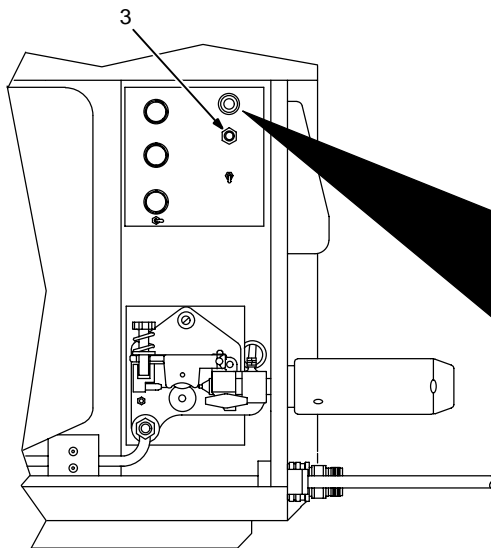
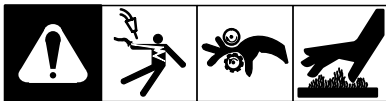

▲ Turn Off wire feeder and welding power source. Stop engine on welding generator.

If fuse opens, unit shuts down. To replace fuse, proceed as follows:

- 1 Fuse Holder Cover
- 2 Fuse F1 (See Parts List)
- 3 Circuit Breaker CB1

If CB1 opens, the gun drive motor, gas valve, and contactor will not operate when trigger is pulled. The gun drive motor operates in the Jog mode with CB1 open.

Check for blocked gun liner.

Check for jammed wire, binding drive gear or misaligned drive rolls in feeder. Correct problem.

Allow cooling period and manually reset breaker. Close and latch door.

Ref. 801 577 / Ref. 800 185-A

6-14. Water Flow Switch (Optional For Water-Cooled Models)

The water flow switch protects the gun from overheating. If coolant flow rate drops below 1 qt/min, the water flow switch opens and stops the welding wire from feeding. See Section 6-15 for remedies to this trouble.

6-15. Troubleshooting



▲ Disconnect power before troubleshooting.

Trouble	Remedy
Pressing gun trigger does not energize feeder. Welding wire is not energized. Shielding gas does not flow.	Secure plug from gun control cable into Gun Control receptacle on feeder (see Section 4-3 or 4-5 as applicable).
	Have nearest Factory Authorized Service Agent check optional water flow switch, if applicable.
Wire feeds, shielding gas flows, but welding wire is not energized.	See Troubleshooting section in welding power source manual.
Wire feeds erratically.	Check position of Motor Torque switch (see Section 5-2).
	Adjust drive roll pressure if necessary (see Section 4-13).
	Clean or replace drive rolls as necessary (see Sections 6-2 and 6-7).
Arc varies and welding wire is kinked when feeding out gun.	Place Motor Torque switch in low torque position if welding with .030 (0.8 mm) aluminum welding wire (see Section 5-2).
No weld output; gun/feeder does not work.	Check gun trigger plug connection on wire feeder front panel (see Sections 4-3 and 4-5).
	Place Power switch on welding power source in the On position.
Erratic weld output.	Tighten and clean all connections.
	Check drive roll pressure in wire feeder and gun (see Section 4-13).
	Check and replace liner if necessary (see Section 6-4 and 6-9).
Wire does not feed; burnback in contact tip.	Check drive roll pressure in wire feeder and gun (see Section 4-13).
	Check and replace liner if necessary (see Section 6-4 and 6-9).
	Reinstall voltage sensing lead (see Section 4-1).
Wire feeds erratically.	Check drive roll pressure in wire feeder and gun (see Section 4-13).
	Clean or replace drive rolls as necessary (see Sections 6-2 and 6-7).
	Check and replace liner if necessary (see Section 6-4 and 6-9).
Gun overheating (water-cooled models).	Be sure coolant flow rate is at least 1 qt/min.
	Corrosion buildup in gun decreasing coolant flow rate. Backflush coolant system, clean coolant system filter, and clean fittings.
Voltmeter does not display voltage	If welding power source does not support pins F and H, a volt sense lead kit must be installed in feeder (see Section 4-7 and 4-8). Volt sensing lead kit 209867.

SECTION 7 – ELECTRICAL DIAGRAMS

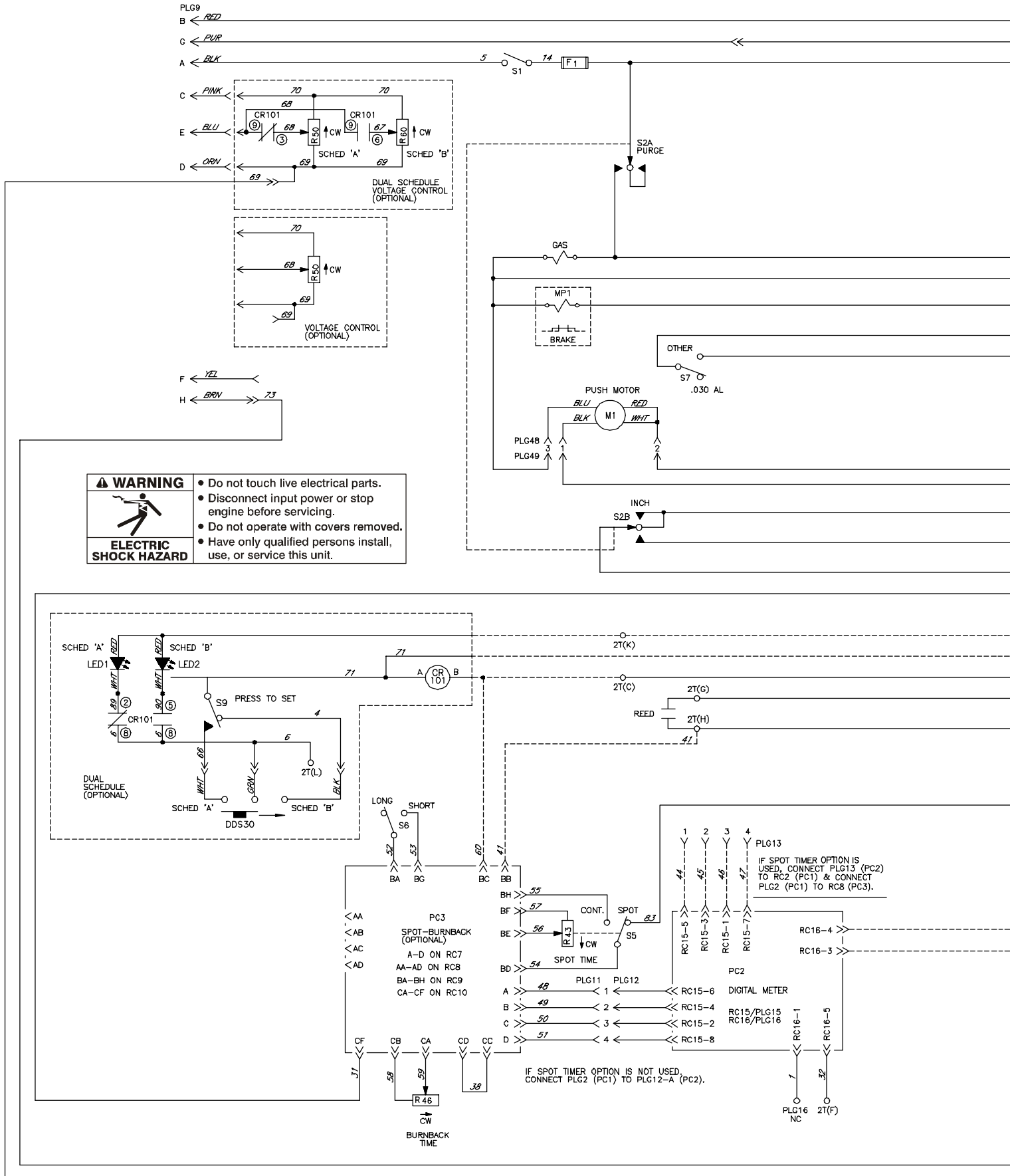
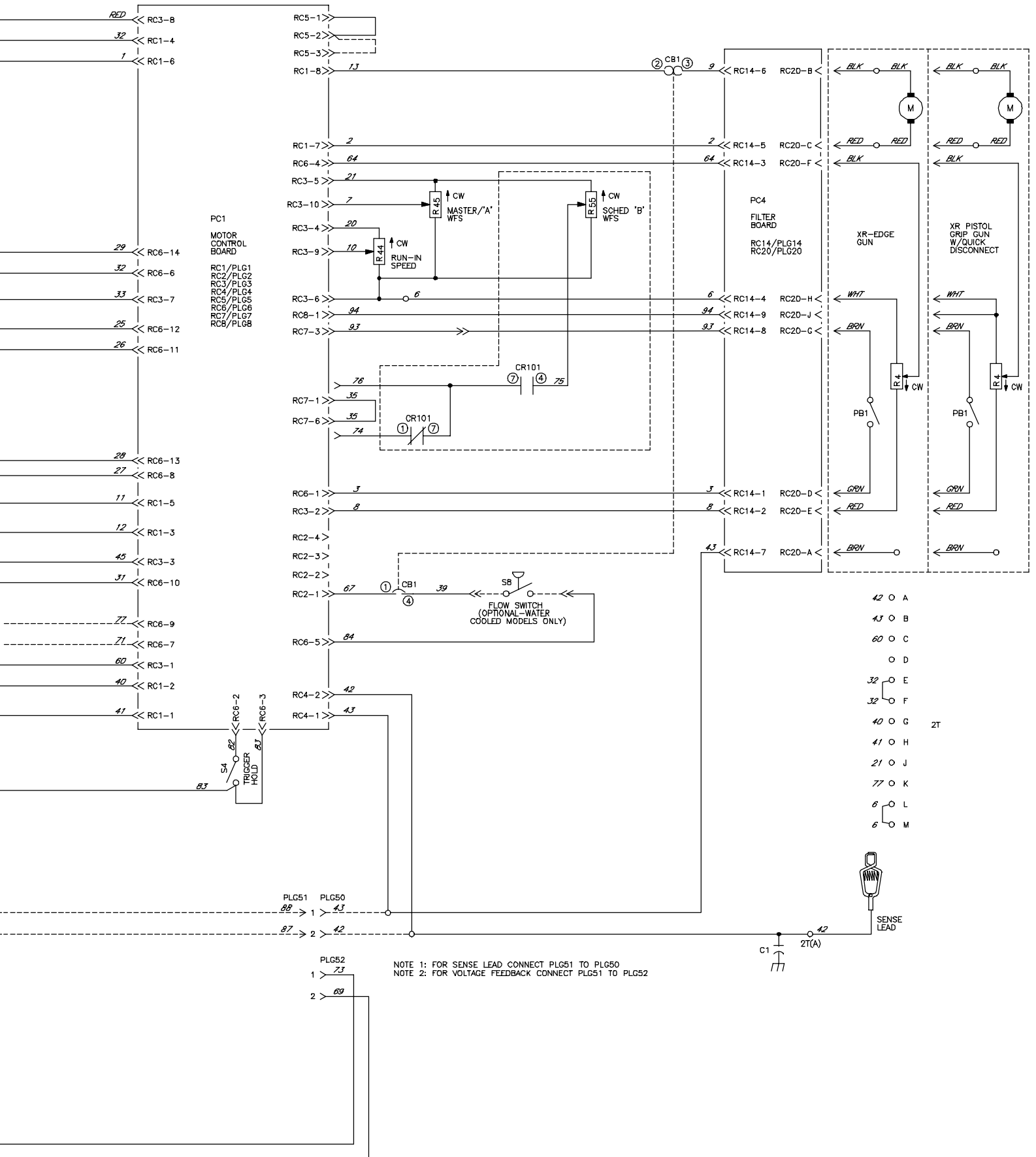
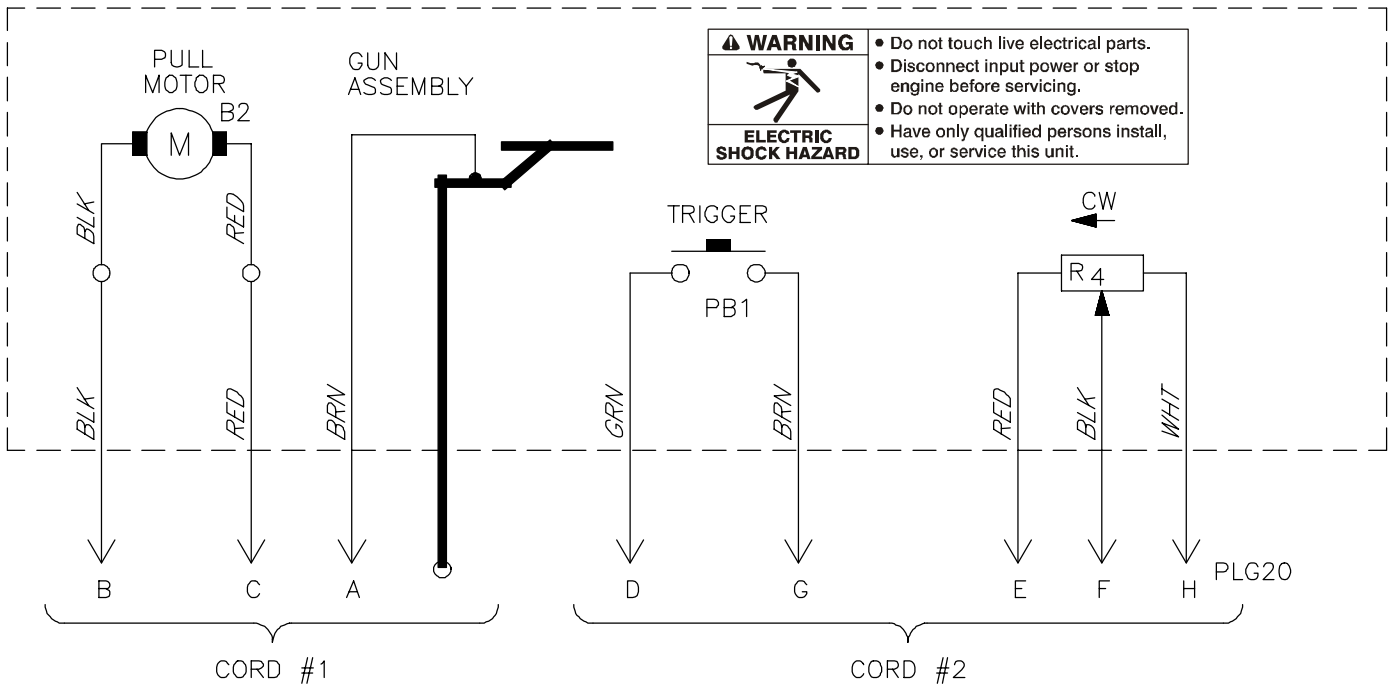

Figure 7-1. Circuit Diagram For Wire Feeder





195 712-A

Figure 7-2. Circuit Diagram For XR Edge Gun

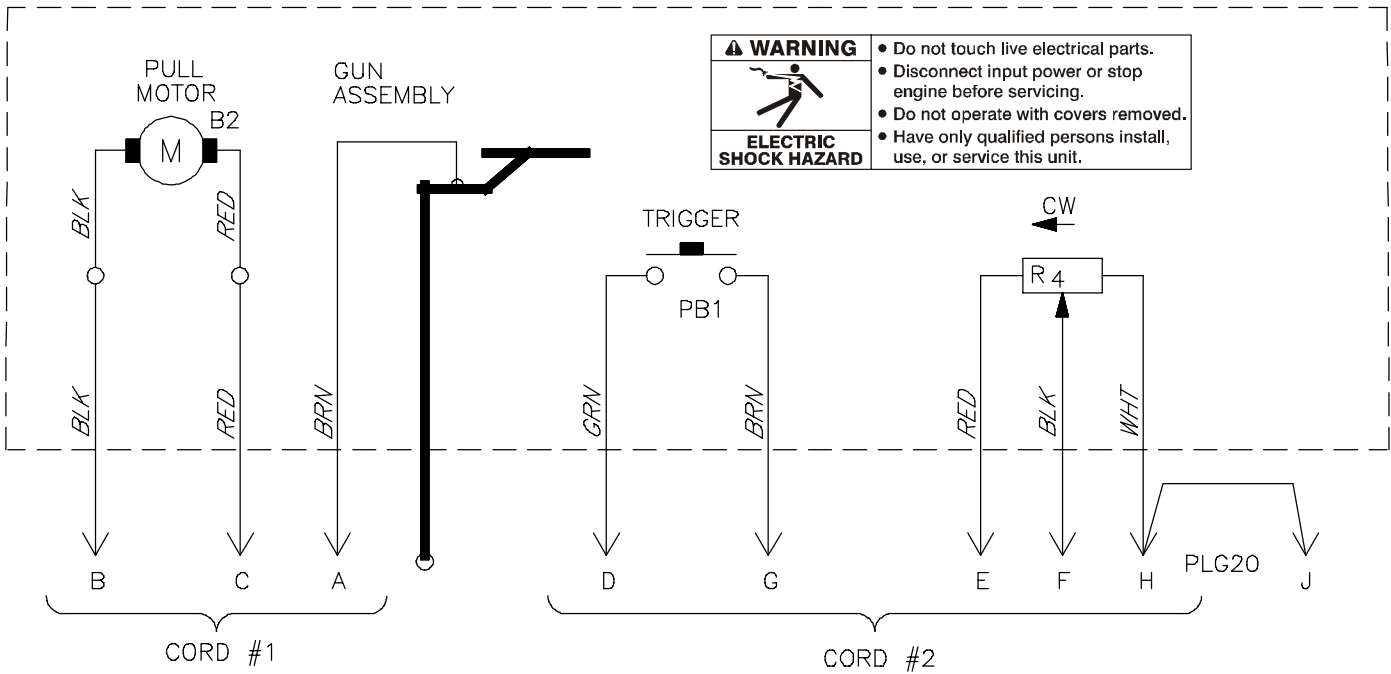

198 344-A

Figure 7-3. Circuit Diagram For XR Pistol Grip Gun

SECTION 8 – PARTS LIST

 Hardware is common and not available unless listed.

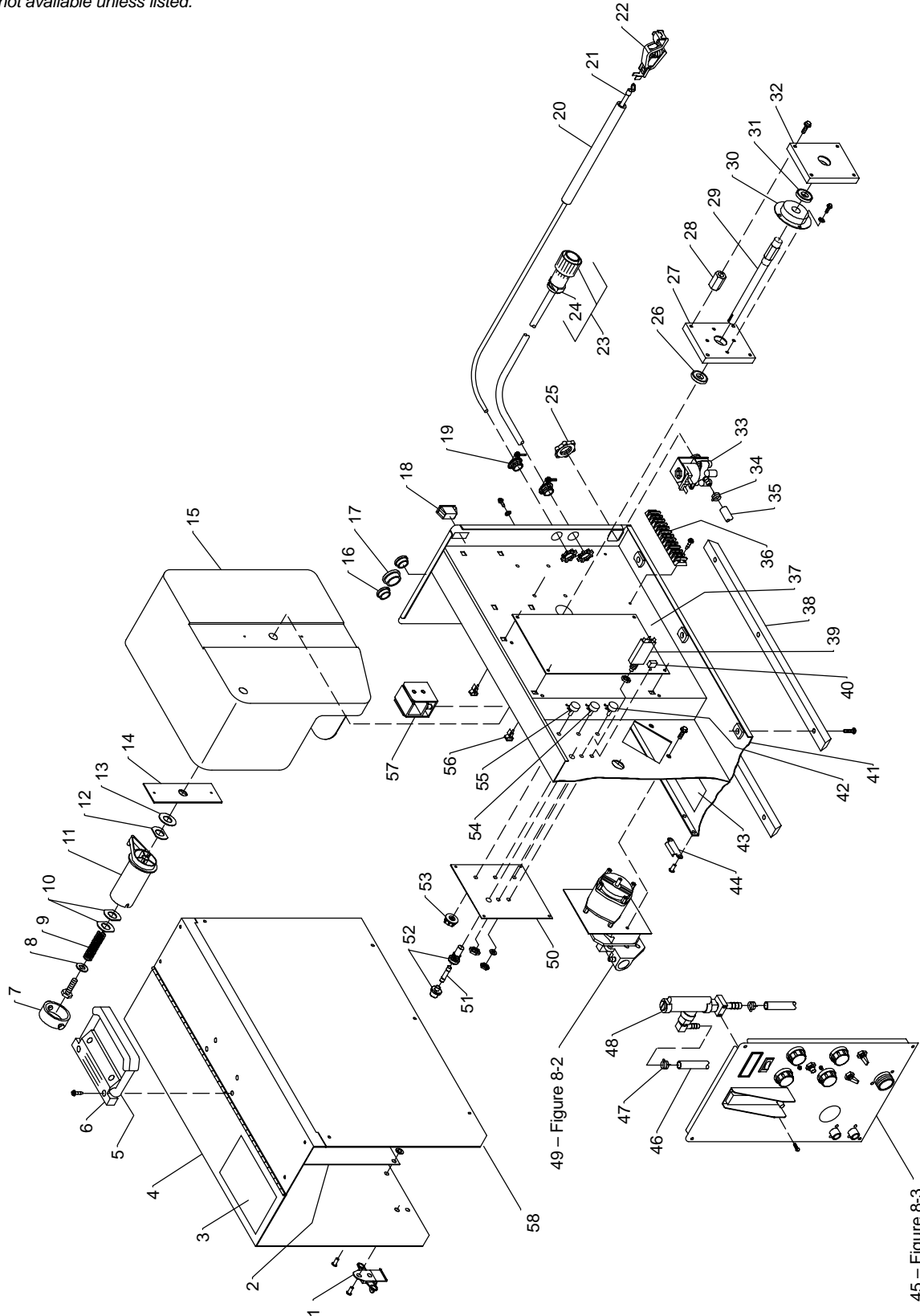

Figure 8-1. Main Assembly

Item No.	Dia. Mkgs.	Part No.	Description	Quantity
----------	------------	----------	-------------	----------

Figure 8-1. Main Assembly

.. 1		089 572	CATCH, link-lock	2
.. 2		112 167	INSULATOR, door	1
.. 3		134 327	LABEL, warning general precautionary (non-CE units)	1
.. 3		178 936	LABEL, warning general precautionary (CE units)	1
.. 4		+169 085	WRAPPER	1
.. 5		126 415	CLAMP, saddle	1
.. 6		126 416	HANDLE, molded	1
.. 7		058 427	RING, retaining spool	1
.. 8		602 233	WASHER, flat stl .250 ID x .875 OD x .062thk	1
.. 9		057 543	SPRING, cprsn .845 OD x .091 wire x 1.500	1
.. 10		113 168	WASHER, locking	2
.. 11		058 428	HUB, spool	1
.. 12		089 561	WASHER, anti-turn stl	1
.. 13		058 424	WASHER, fbr brake	1
.. 14		151 697	STRIP, brake surface anti-turn	1
.. 15		112 198	SHROUD, spool wire 12 in	1
.. 16		057 357	BUSHING, snap-in nyl .937 ID x 1.125mtg hole	2
.. 17		010 494	BUSHING, snap-in nyl 1.375 ID x 1.750mtg hole	1
.. 18	S1	111 997	SWITCH, rocker SPST 10A 250VAC	1
.. 19		115 104	CONNECTOR, clamp cable .500	2
.. 20	◆◆◆	176 089	TUBING, plstc PVC black	1ft
.. 21	◆◆◆	600 399	WIRE, strd 14ga(order by ft)	35ft
.. 22	◆◆◆	601 222	CLAMP, univ 50A	1
.. 23	PLG5	141 162	HOUSING PLUG & PINS	1
.. 24		079 739	CLAMP, cable strain relief	1
..		182 475	CABLE, port no 18 6/c 10 ft 8 in	1
.. 25		605 227	NUT, .750-14 knurled nyl	1
.. 26		073 302	BEARING, ball rdl sgl row .669 x 1.378 x .39	1
.. 27		113 161	BLOCK, bearing front	1
.. 28		113 165	STAND-OFF, .250-20 x 1.000 lg	4
.. 29		120 396	SHAFT, spool	1
.. 30	MP1	163 304	BRAKE, w/terminals	1
.. 31		073 302	BEARING, ball rdl sgl row .669 x 1.378 x .39	1
.. 32		113 900	BLOCK, bearing rear	1
.. 33	GS1	125 785	VALVE, 24VAC 2way custom port 1/8 orf	1
.. 34		089 120	CLAMP, hose .375-.450clp dia slftng	1
.. 35		176 357	HOSE, SAE .187 ID x .410 OD x 21.000	1
.. 36	2T	038 783	BLOCK, term 20A 12P	1
..		601 219	LINK, jumper	2
..		111 008	LABEL, term mkg	1
.. 37	PC1	198 975	CIRCUIT CARD, motor speed control	1
.. 38		105 567	SKID, base	2
.. 39	CB1	011 991	CIRCUIT BREAKER, main reset	1
.. 40	S7	011 770	SWITCH, tgl SPDT 6A 125V	1
.. 41		+187 704	CABINET, control	1
.. 42		◆194 282	POTENTIOMETER, C sltd sft 1T 1W 1M	1
.. 43		090 439	LABEL, warning electric shock can kill	1
.. 44		089 573	PLATE, keeper link-lock	2
.. 45		Fig 8-3	PANEL, front w/components	1
.. 46	◆◆◆	134 834	HOSE, SAE .187 ID X .410 OD (order by ft)	2ft
.. 47	◆◆◆	089 120	CLAMP, hose .375-.450clp dia slftng	4
.. 48	S8	◆◆◆194 195	SWITCH, flow w/fittings	1
.. 49		Fig 8-2	MOTOR & WIRE DRIVE	1
.. 50		187 789	PLATE, control side (non-CE units)	1
.. 50		197 645	PLATE, control side (CE units)	1
.. 51	F1	*073 426	FUSE, mintr gl slo-blo 5A	1
.. 52		046 432	HOLDER, fuse mintr .250 x 1.250 panel mtg	1
.. 53		193 919	KNOB, pointer	2

Item No.	Dia. Mkgs.	Part No.	Description	Quantity
----------	------------	----------	-------------	----------

Figure 8-1. Main Assembly (Continued)

.. 54	◆028 770 ..	POTENTIOMETER, CP std slot 1T 2W 1M	1
.. 55	073 562 ..	POTENTIOMETER, CP std slot 1T 2W 10k	1
.. 56	134 201 ..	STAND-OFF SUPPORT, PC card .312/.375	4
.. 57 ...	REED	140 786 .. SWITCH, reed	1
.. 58	169 089 ..	DOOR, side rh	1

+When ordering a component originally displaying a precautionary label, the label should also be ordered.

◆Part of 114 144 Spot Weld Control Option

◆◆Part of 144 931 Voltage Control Option

◆◆◆Part of 130 838 Water Flow Shutdown Switch Option

◆◆◆◆Part of 209 867 Voltage Sensing Lead Kit

*Recommended Spare Parts.

To maintain the factory original performance of your equipment, use only Manufacturer's Suggested Replacement Parts. Model and serial number required when ordering parts from your local distributor.

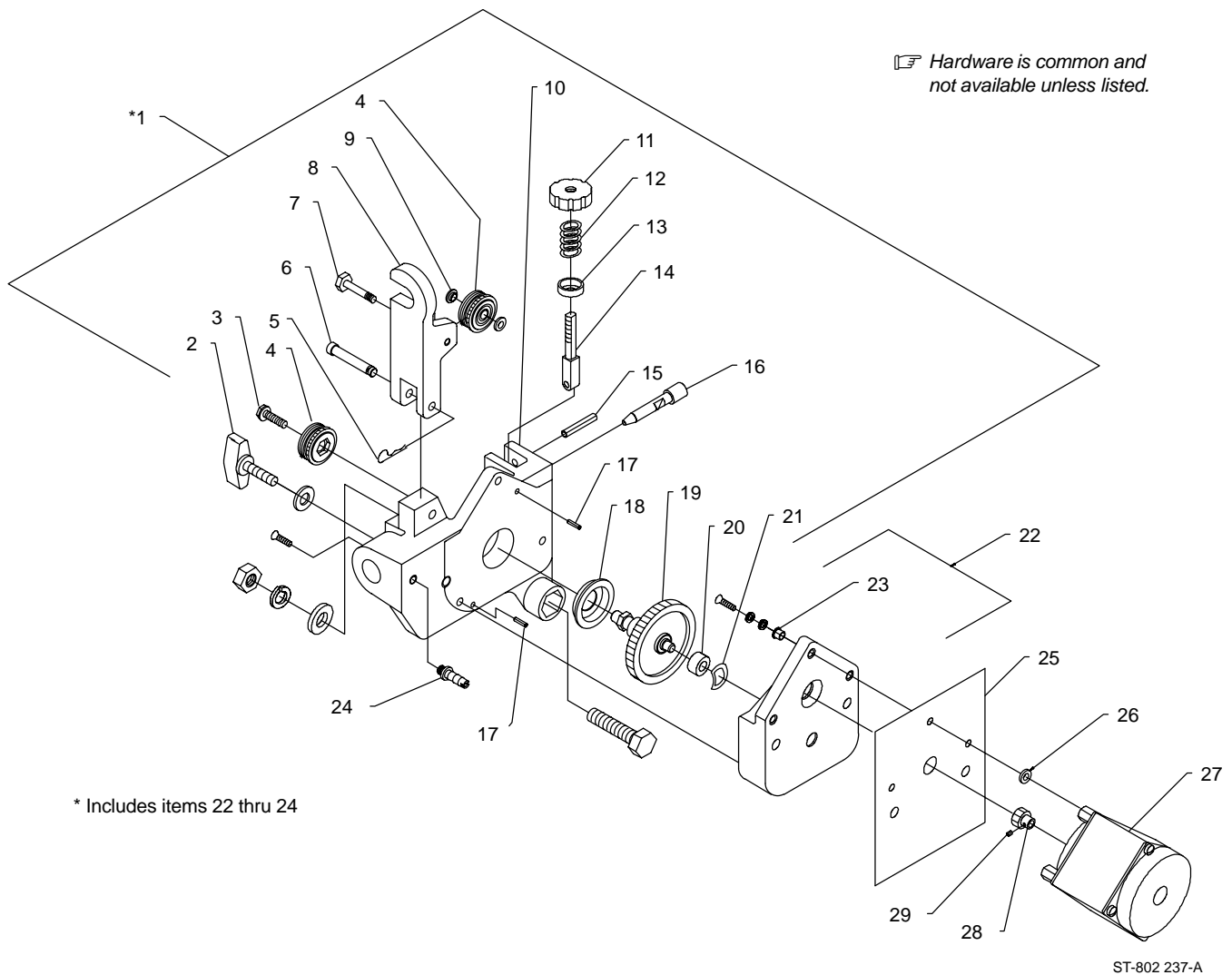

Figure 8-2. Motor & Wire Drive

Item No.	Dia. Mkgs.	Part No.	Description	Quantity
Figure 8-2. Motor & Wire Drive (Figure 8-1 Item 49)				
1		193 186	DRIVE ASSEMBLY, wire (consisting of)	1
2		124 778	KNOB, T 2.000 bar w/.312 - 18 nut	1
3		111 630	SCREW, 010-32 x .25 hexwhd-pln stl pld	1
4		◆194 118	KIT, drive roll .030-.035 (Part of Wire Guide Kits 193 520 and 193 521)	1
4		◆194 119	KIT, drive roll .047-.062 (Part of Wire Guide Kit 193 522)	1
4		◆195 591	KIT, drive roll .062 (Part of Wire Guide Kit 193 523)	1
5		151 828	PIN, cotter hair .042 x .750	1
6		090 416	PIN, hinge	1
7		191 826	SCREW, mtg idler roll	1
8		189 714	PRESSURE ARM	1
9		◆188 098	WASHER, shldr .192 ID x .375 OD	2
10		189 716	HOUSING, wire drive	1
11		092 237	KNOB, adjust tension 1.000	1
12		189 911	SPRING, cprsn .720 OD x .063 wire x 1.500	1
13		085 244	WASHER, cupped .328 ID x .812 OD x 16 ga x .125 lip	1
14		085 242	FASTENER, pinned	1
15		010 224	PIN, spring CS .187 x 1.000	1
16		058 549	GUIDE, wire inlet 1/16	1
17		602 306	PIN, spring CS .125 x .500	2
18		189 823	INSULATOR, front bearing	1
19		189 920	GEAR ASSY, shaft/bearing	1
20		189 605	BEARING ASSY, upper drive shaft	1
21		079 625	WASHER, wave .500 ID x .750 OD	1
22		196 613	CASE, gear wire drive (consisting of)	1
23		196 604	WASHER, shldr .187 ID .343 OD x .045T .234 OD x .138T nyl	3
24		144 172	FITTING, hose brs barbed M 3/16 tbg x .250-20	1
25		113 162	INSULATOR, motor	1
26		605 798	WASHER, shldr .168 ID 0.375 OD x .047T .246 OD x .030T nyl	3
27	B1	163 326	MOTOR, torque 24VAC 50/60Hz	1
28		113 169	GEAR, driver	1
29		604 612	SCREW, set stl sch 8-32 x .125 cup point	1

◆ Part of 194 118, 194 119, or 195 591 Drive Roll Kits

To maintain the factory original performance of your equipment, use only Manufacturer's Suggested Replacement Parts. Model and serial number required when ordering parts from your local distributor.

☞ Hardware is common and not available unless listed.

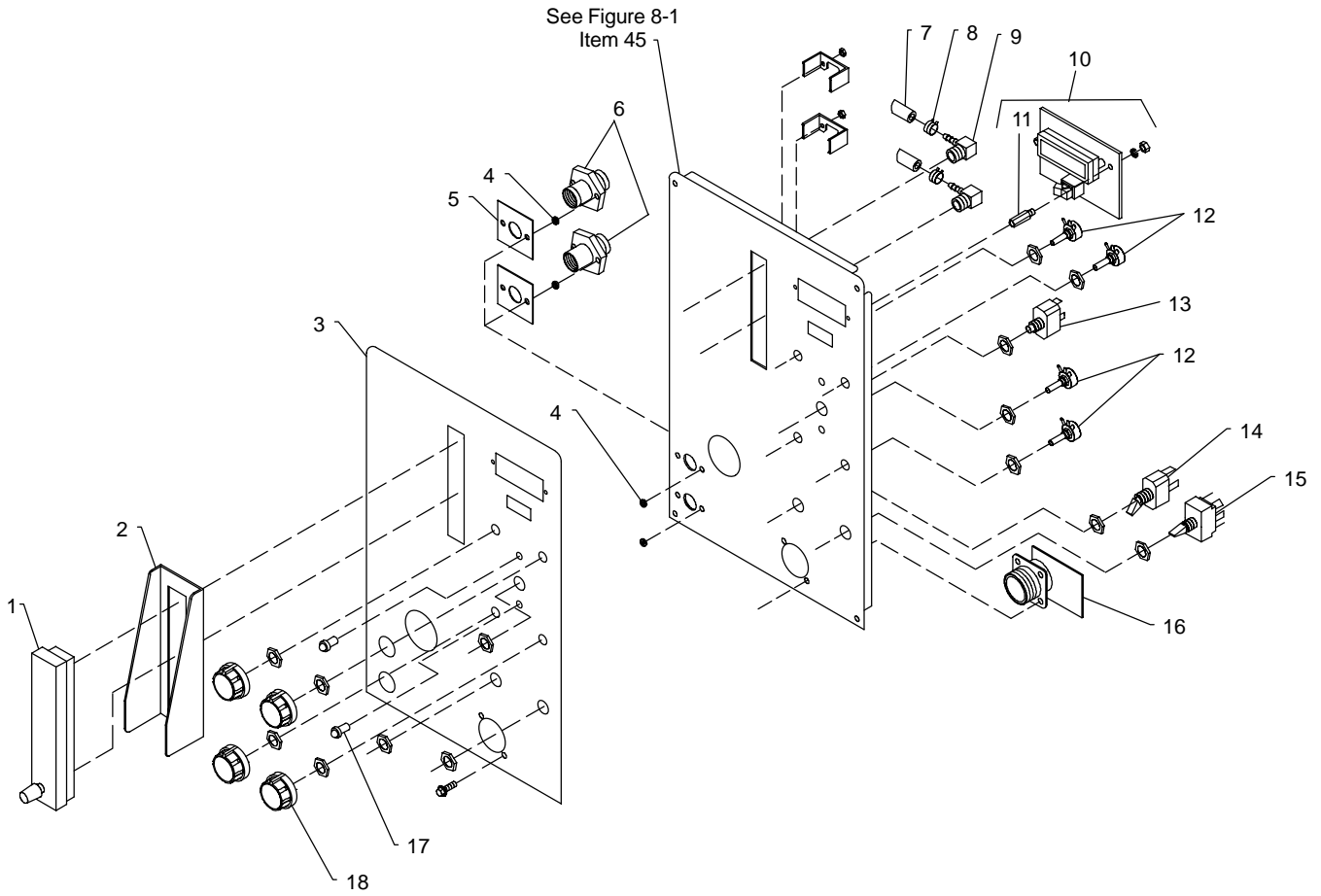

802 236-A

Figure 8-3. Panel, Front w/Components (Water-Cooled Model Illustrated)

Item No.	Dia. Mkgs.	Part No.	Description	Quantity
----------	------------	----------	-------------	----------

Figure 8-3. Panel, Front w/Components (Figure 8-1 Item 45)

...	1	...	◆ 111 569	...	METER, flow 6-60	...	1
...	2	...	◆ 111 633	...	GUARD, flow meter	...	1
...	3	NAMEPLATE, (order by model and serial number)	...	1
...	4	...	605 798	...	WASHER, shldr. nyl	...	8
...	5	...	173 259	...	INSULATOR, water flow switch	...	2
...	6	...	139 678	...	FITTING, water (supplied with water-cooled gun)	...	2
...	7	...	◆ 176 357	...	HOSE, SAE .187 ID x .410 OD (order by ft)	...	4ft
...	8	...	◆ 089 120	...	CLAMP, hose .375-.450clp dia	...	2
...	9	...	◆ 112 090	...	FITTING, pipe brs elb 1/8NPT x 3/16 hose	...	2
...		...	◆ 056 851	...	FITTING, hose brs barbed nipple 3/16tbg	...	2
...		...	◆ 010 606	...	FITTING, hose brs nut .625-18	...	2
...		...	◆ 056 108	...	FITTING, hose brs ferrule .425 ID x .718 lg	...	2
...		...	◆ 045 852	...	CLIP, component .687dia mtg adh back	...	1
...	10	PC2	186 268	...	CIRCUIT CARD, meter (consisting of)	...	1
...	11	...	115 443	...	STAND-OFF, No. 6-32 x .750 lg	...	2
...		...	133 644	...	FRAME, snap-in switch rocker panel mtg	...	1
...	12	...	073 562	...	POTENTIOMETER, CP std slot 1T 2W	...	4
...	13	...	011 232	...	SWITCH, PB SPDT	...	1
...	14	S4	134 847	...	SWITCH, tgl SPDT 15A 125VAC	...	1
...	15	S2	134 846	...	SWITCH, tgl SPTT 6A 125VAC	...	1
...	16	PC4, RC20	193 945	...	CIRCUIT CARD, filter	...	1
...		...	146 212	...	PLUG, 10 pin MS-3106A-18-1PX Amphenol	...	1
...		PLG14	115 092	...	HOUSING PLUG & SOCKETS	...	1
...	17	...	194 152	...	LED, green	...	2
...	18	...	193 919	...	KNOB, pointer	...	5

◆ Part of 114 101 Gas Flow Meter Option.

To maintain the factory original performance of your equipment, use only Manufacturer's Suggested Replacement Parts. Model and serial number required when ordering parts from your local distributor.

 Hardware is common and not available unless listed.

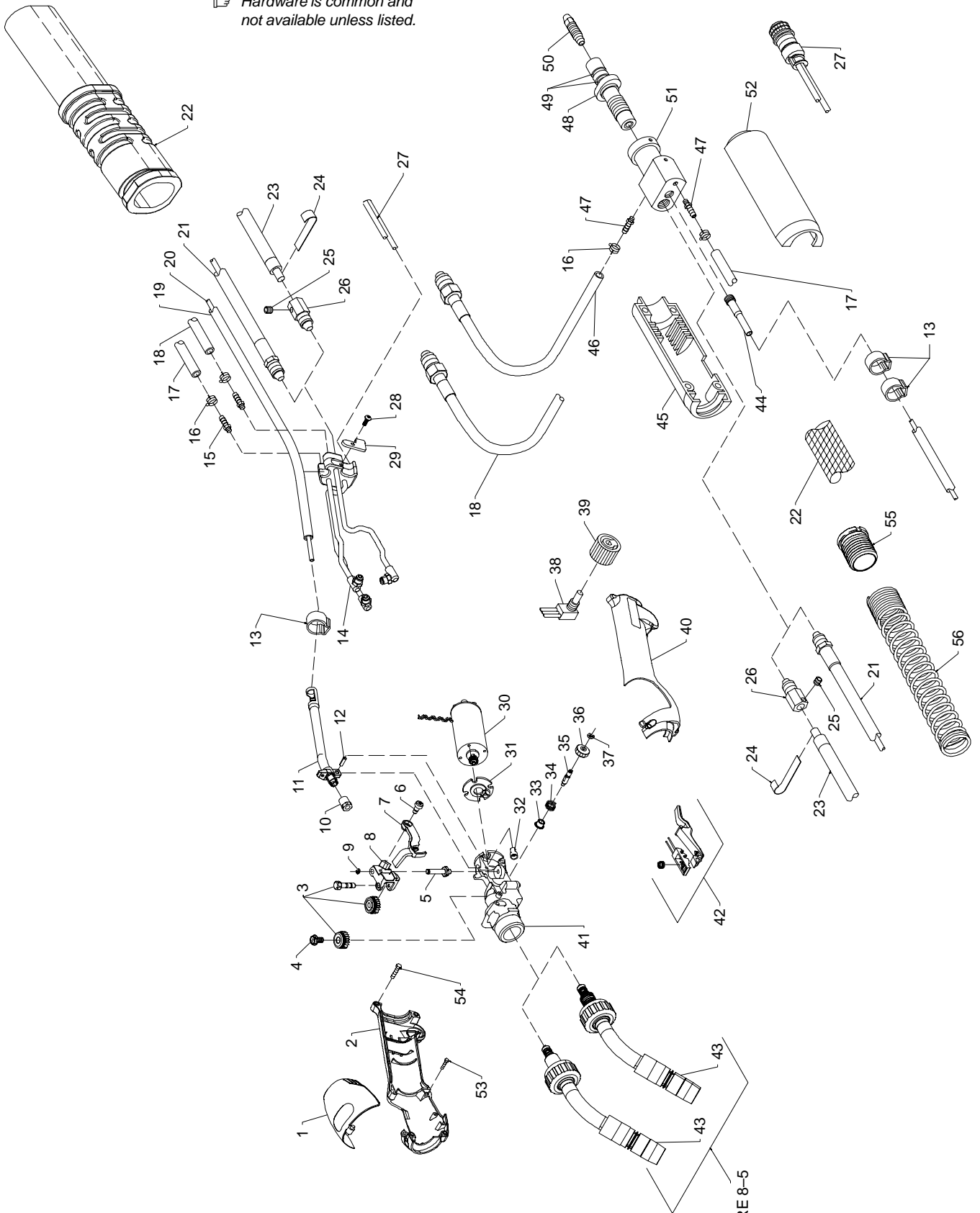

SEE FIGURE 8-5

Figure 8-4. Exploded View Of XR-Edge Gun

Item No.	Dia. Mkgs.	Part No.	Description	Quantity
----------	------------	----------	-------------	----------

Figure 8-4. Exploded View Of XR-Edge Gun

...	1	187 000	COVER,handle	1
...	2	187 002	HANDLE, right	1
...	3	194 114	KIT, drive roll .030 (Part of Wire Guide Kit 193 520)	1
...	3	194 115	KIT, drive roll .035 (Part of Wire Guide Kit 193 521)	1
...	3	194 116	KIT, drive roll .047 (Part of Wire Guide Kit 193 522)	1
...	3	194 117	KIT, drive roll .062 (Part of Wire Guide Kit 193 523)	1
...	3	◆191 135	SHAFT, hot drive roll	1
...	4	◆111 630	SCREW, 010-32 x .25 hexwhd slt	1
...	5	185 098	PIN, pressure	1
...	6	191 098	SCREW, shld stl sch 008-32 x .188 x .188 shld	1
...	7	191 097	ARM, tension	1
...	8	191 096	ARM, pressure	1
...	9	000 364	RING, rtng ext .188 shaft x .025 thk E style	1
...	10	185 106	NUT, liner collet	1
...	11	191 090	GUIDE ASSY, liner	1
...	12	602 306	PIN, spring cs .125 x .500	1
...	13	203 557	CLAMP, 1-ear type nom dim .391 x .236 wide special	3
...	14	191 104	POWER BLOCK ASSY	1
...	15	135 580	FITTING, gas (air)	1
...	15	135 580	FITTING, gas (water)	2
...	16	149 332	CLAMP, hose .405 - .485 clp dia (air)	2
...	16	149 332	CLAMP, hose .405 - .485 clp dia (water)	4
...	17	191 058	HOSE, gas in 15ft	1
...	17	191 059	HOSE, gas in 30ft	1
...	17	191 060	HOSE, gas in 50ft	1
...	18	191 072	HOSE, water in 15ft	1
...	18	191 073	HOSE, water in 30ft	1
...	18	191 074	HOSE, water in 50ft	1
...	19	203 599	CONDUIT, monocoil double wound 15ft	1
...	19	203 671	CONDUIT, monocoil double wound 30ft	1
...	19	203 673	CONDUIT, monocoil double wound 50 ft	1
...	20	191 064	LINER, .187 OD x .110 ID (15ft)	1
...	20	191 065	LINER, .187 OD x .110 ID (30ft)	1
...	20	191 066	LINER, .187 OD x .110 ID (50ft)	1
...	21	191 052	CABLE, power/water out 15ft	1
...	21	191 053	CABLE, power/water out 30ft	1
...	21	191 054	CABLE, power/water out 50ft	1
...	22	203 579	JACKET, cable combination 15ft w/molded strain relief	1
...	22	203 672	JACKET, cable combination 30ft w/molded strain relief	1
...	22	203 674	JACKET, cable combination 50ft w/molded strain relief	1
...	23	191 049	CABLE, power 15ft (air)	1
...	23	191 050	CABLE, power 30ft (air)	1
...	23	191 051	CABLE, power 50ft (air)	1
...	24	152 577	STRIP, copper .010 x 2.000 x .750 (air)	1
...	25	141 694	SCREW, set 312-18 x .37 conept sch stl pln	1
...	26	137 495	FITTING, connection power weld	1
...	27	191 055	CABLE, control 15ft	1
...	27	191 056	CABLE, control 30ft	1
...	27	191 057	CABLE, control 50ft	1
...	28	191 121	SCREW, 006-32 x .37 btn hd-soc	1
...	29	191 119	STRAIN RELIEF, cable	1
...	30	191 082	MOTOR ASSY	1
...	31	189 078	INSULATOR, motor	1
...	32	190 906	INSULATOR, motor screw	4
...	33	191 131	SPACER, tension	1
...	34	191 141	SPRING, cprsn .360 OD x .032 wire x .875 free	1
...	35	190 907	SHAFT, spring tension	1
...	36	135 773	KNOB, adjust tension thumb	1
...	37	191 087	RING, rtng ext .094 shaft x .015 thk E style	1

Item No.	Dia. Mkgs.	Part No.	Description	Quantity
Figure 8-4. Exploded View Of XR-Edge Gun (Continued)				
... 38	...	191 235	.. POTENTIOMETER, CP flat 1T .5W 10K ohm	1
... 39	...	191 205	.. KNOB, speed control	1
... 40	...	187 001	.. HANDLE, left	1
... 41	...	196 045	.. HOUSING, drive w/gears	1
... 42	...	191 212	.. TRIGGER ASSY	1
... 43	...	194 255	.. HEAD TUBE ASSY, water (see Figure 8-5)	1
... 43	...	194 073	.. HEAD TUBE ASSY, air (see Figure 8-5)	1
... 44	...	203 539	.. FITTING, liner	1
... 45	...	189 812	.. HOUSING, power pin RH	1
... 46	...	196 177	.. HOSE, water out 10in	1
... 47	...	202 513	.. FITTING, hose brs barbed M 3/16 tbg x .250-20 (air)	1
... 47	...	202 513	.. FITTING, hose brs barbed M 3/16 tbg x .250-20 (water)	2
... 48	...	193 896	.. PIN, power assembly (consisting of)	1
... 49	...	079 974	.. O-RING, .500 ID x .103 cs rbr	2
... 50	...	202 216	.. GUIDE, wire outlet .030-1/16	1
... 51	...	187 029	.. CONNECTOR, power/gas	1
... 52	...	189 811	.. HOUSING, power pin LH	1
... 53	...	156 579	.. SCREW, 004-40 x .37 soc hd-hex stl pld	1
... 54	...	143 480	.. SCREW, 006-32 x .62 soc hd-hex gr 8 pld	5
... 55	...	203 560	.. STRAIN RELIEF, spring retainer	1
... 56	...	203 562	.. SPRING, strain relief	1
...	...	◆605 107	.. GREASE MINICAP	1

◆Part of 194 114, 194 115, 194 116, or 194 117 Drive Roll Kits

To maintain the factory original performance of your equipment, use only Manufacturer's Suggested Replacement Parts. Model and serial number required when ordering parts from your local distributor.

Hardware is common and not available unless listed.

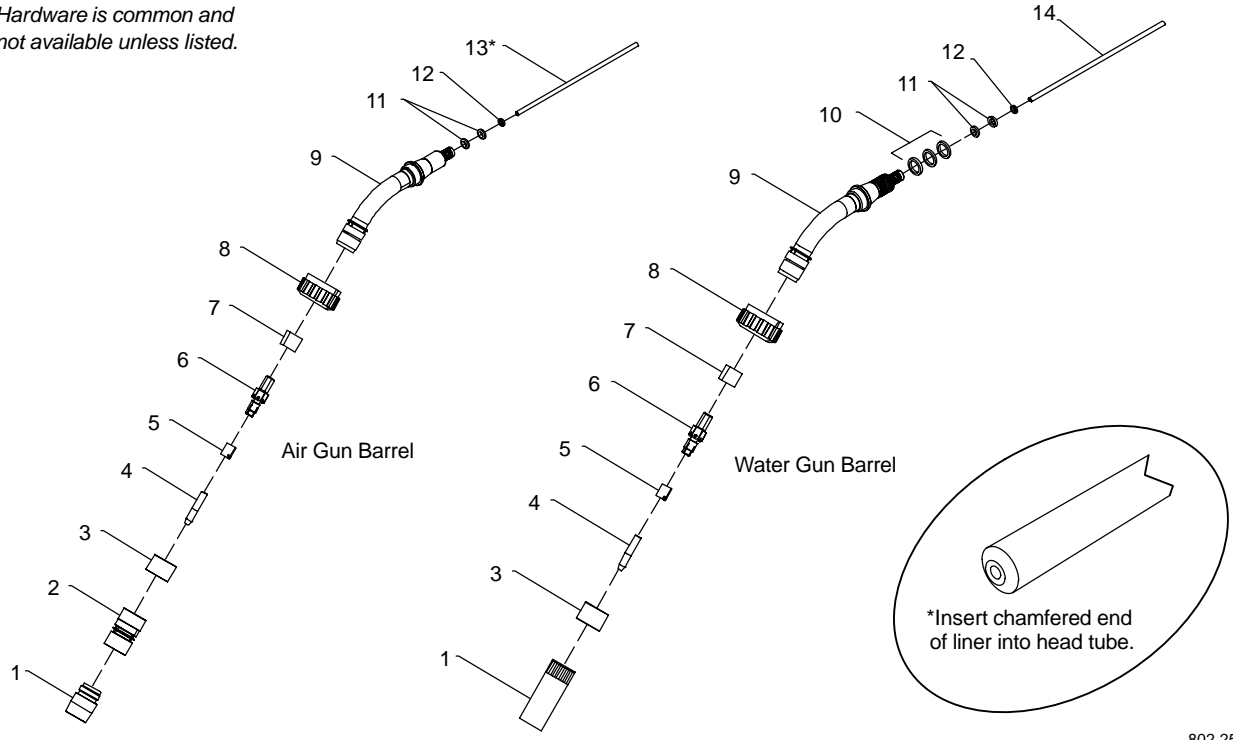

802 253-A

Figure 8-5. Barrel Assembly Of XR-Edge Gun

Item No.	Dia. Mkgs.	Part No.	Description	Quantity
----------	------------	----------	-------------	----------

Figure 8-5. Barrel Assembly Of XR-Edge Gun (Figure 8-4 Item 41)

...	1	197 728	.. NOZZLE, 5/8 orf x 2-1/2 (water)	1
...	1	185 100	.. NOZZLE, 5/8 orf x 1-3/8 (air)	1
...	2	185 105	.. NOZZLE, adapter (air)	1
...	3	185 102	.. NUT, nozzle adapter locking	1
...	4	135 428	.. TIP, contact .030/41 wire (part of Wire Guide Kit 193 520)	1
...	4	135 430	.. TIP, contact .035/52 wire (part of Wire Guide Kit 193 521)	1
...	4	135 430	.. TIP, contact .040/52 wire (part of Wire Guide Kit 196 300)	1
...	4	135 424	.. TIP, contact .047/61 wire (part of Wire Guide Kit 193 522)	1
...	4	135 425	.. TIP, contact .062/81 wire (part of Wire Guide Kit 193 523)	1
...	4	◆135 427	.. TIP, contact .030/36 wire	1
...	4	◆147 314	.. TIP, contact .035/41 wire	1
...	4	◆135 429	.. TIP, contact .047/52 wire	1
...	4	◆135 426	.. TIP, contact .062/73 wire	1
...	5	136 748	.. COLLET, nut (part of Wire Guide Kits)	1
...	6	185 110	.. ADAPTER, quick change contact tip	1
...	7	185 097	.. INSULATOR, contact tip adapter	1
...	8	185 111	.. NUT, molded head tube rotation	1
...	9	191 180	.. HEAD TUBE, air (consisting of)	1
...	9	191 181	.. HEAD TUBE, water	1
...	10	194 261	.. O-RING, .551 ID x .070CS (water)	3
...	11	191 191	.. O-RING, .312 ID x .070CS	2
...	12	164 485	.. O-RING, .176 ID x .070CS	1
...	13	◆◆193 792	.. LINER, .045-1/16 wire x 7.188 lg (air)	1
...	13	◆◆◆193 793	.. LINER, .023-.040 wire x 7.188 lg (air)	1
...	14	◆◆197 730	.. LINER, .045-1/16 wire x 7.875 lg (water)	1
...	14	◆◆◆197 729	.. LINER, .023-.040 wire x 7.875 lg (water)	1

◆Optional

◆◆Part of 193 522 and 193 523 Wire Guide Kit Options

◆◆◆Part of 193 520 and 193 521 Wire Guide Kit Options

To maintain the factory original performance of your equipment, use only Manufacturer's Suggested Replacement Parts. Model and serial number required when ordering parts from your local distributor.

 Hardware is common and not available unless listed.

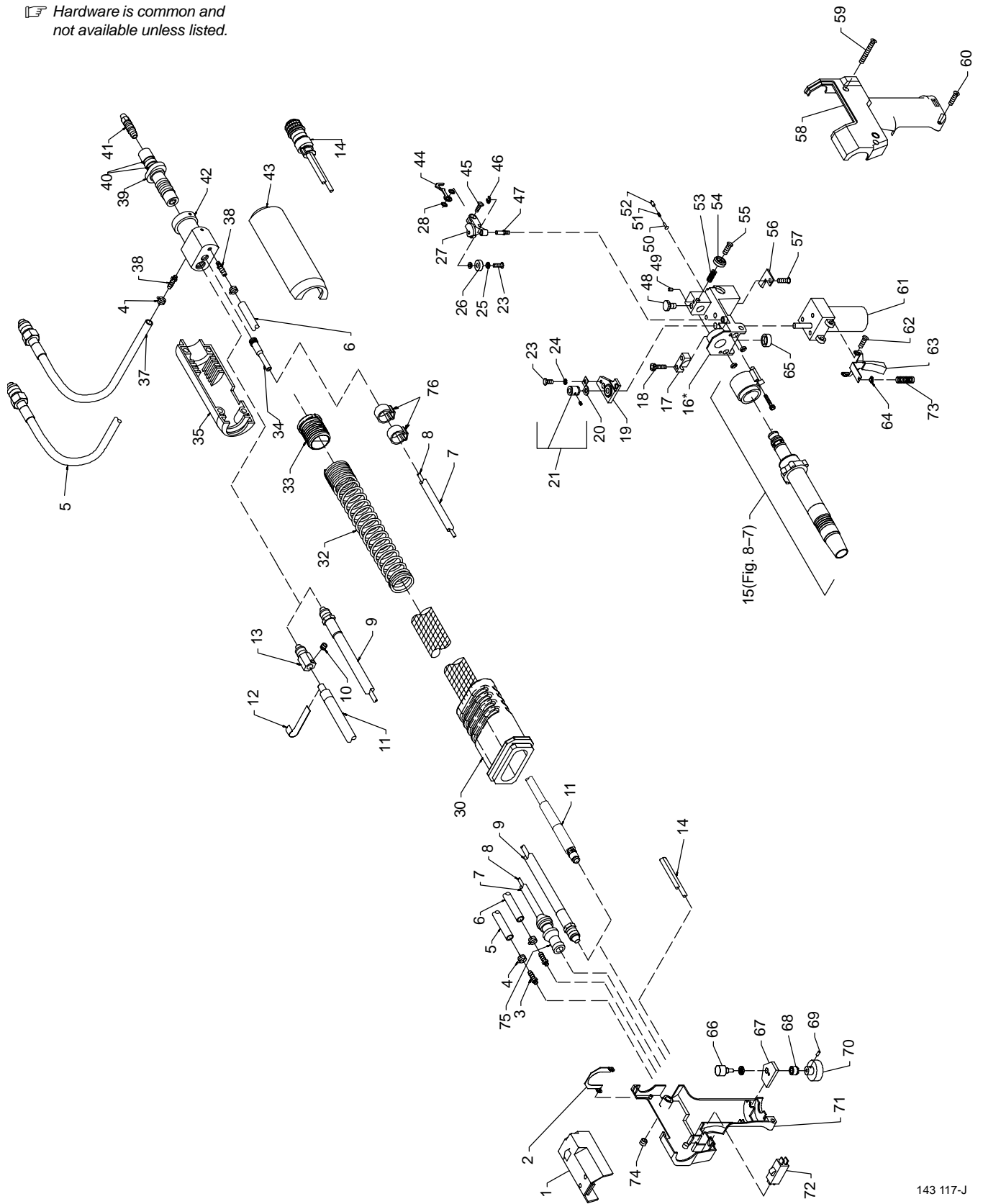

Figure 8-6. Exploded View Of Pistol-Grip Gun

143 117-J

Item No.	Dia. Mkgs.	Part No.	Description	Quantity
----------	------------	----------	-------------	----------

Figure 8-6. Exploded View Of Pistol-Grip Gun

.. 1	133 479	.. COVER	1
.. 2	135 196	.. SPRING, closure cover	1
.. 3	135 580	.. FITTING, gas (air)	1
.. 3	135 580	.. FITTING, gas (water)	2
.. 4	149 332	.. CLAMP, hose .405 – .485 clp dia (air)	2
.. 4	149 332	.. CLAMP, hose .405 – .485 clp dia (water)	4
.. 5	191 072	.. HOSE, water in 15ft	1
.. 5	191 073	.. HOSE, water in 30ft	1
.. 6	191 058	.. HOSE, gas in 15ft	1
.. 6	191 059	.. HOSE, gas in 30ft	1
.. 7	203 691	.. CONDUIT W/FITTING, molded 15 ft	1
.. 7	203 691	.. CONDUIT W/FITTING, molded 30 ft	1
.. 8	191 064	.. LINER, .187 OD x .110 ID (15ft)	1
.. 8	191 065	.. LINER, .187 OD x .110 ID (30ft)	1
.. 9	191 052	.. CABLE, power/water out 15ft	1
.. 9	191 053	.. CABLE, power/water out 30ft	1
.. 10	141 694	.. SCREW, set 312-18 x .37 conept sch stl pln	1
.. 11	203 758	.. CABLE, power 15ft (air)	1
.. 11	203 759	.. CABLE, power 30ft (air)	1
.. 12	152 577	.. STRIP, copper .010 x 2.000 x .750 (air)	1
.. 13	137 495	.. FITTING, connection power weld	1
.. 14	198 330	.. CABLE, control 15ft	1
.. 14	196 466	.. CABLE, control 30ft	1
.. 15	Fig 8-7	.. BARREL ASSEMBLY	1
.. 16	163 704	.. HOUSING, wire drive (15A & 30A models) (includes items 3, 48, 50, 51, 52, 60 & 65)	1
.. 16	163 692	.. HOUSING, wire drive (15W & 30W models) (includes items 3, 48, 50, 51, 52, 60 & 65)	1
..	151 661	.. SCREW, set 10-32 x .125 cup sch (30W models only)	2
.. 17	133 365	.. CLAMP, head tube	1
.. 18	000 417	.. SCREW, cap stl sch 10-24 x 1.000	2
.. 19	162 041	.. BEARING BLOCK ASSEMBLY	1
..	604 638	.. SCREW, cap stl sch 6-32 x .375	3
..	143 480	.. SCREW, 6-32 x .625 soc hd-hex stl	1
.. 20	162 042	.. CONTACT, current pick-up	1
.. 21	◆136 135	.. ROLL, drive VK groove .023-1/16 wire (consisting of)	1
..	◆604 612	.. SCREW, set stl sch 8-32 x .125 cup point	2
.. 21	◆183 357	.. KIT, drive VK groove .030-.035 wire (part of wire guide kit 198 384)	1
.. 21	◆183 357	.. KIT, drive VK groove .040 wire (part of wire guide kit 198 383)	1
.. 21	◆183 358	.. KIT, drive VK groove .047-.062 wire (part of wire guide kit 198 382)	1
.. 21	◆183 358	.. KIT, drive VK groove .047-.062 wire (part of wire guide kit 198 381)	1
.. 23	114 045	.. SCREW, 6-32 x .500 hexwhd slit stl slffmg	3
.. 24	602 198	.. WASHER, lock .141 ID stl split	4
.. 25	134 624	.. BEARING, flg nyl .140 ID x .187 OD x .375flg x .031thk	2
.. 26	134 623	.. BEARING, idler roll	1
.. 27	132 852	.. ARM, pressure	1
.. 28	605 798	.. WASHER, shldr nyl .375 OD x .168 ID x .080	2
.. 30	203 689	.. JACKET, cable combination 15ft molded strain relief	1
.. 30	203 690	.. JACKET, cable combination 30ft molded strain relief	1
.. 32	203 562	.. SPRING, strain relief	1
.. 33	203 560	.. STRAIN RELIEF, spring retainer	1
.. 34	203 539	.. FITTING, liner double wound adapter	1
.. 35	189 812	.. HOUSING, power pin RH	1
.. 37	166 412	.. HOSE, water 14in	1
.. 38	202 513	.. FITTING, hose brs barbed M 3/16 tbg x .250-20 (air)	1
.. 38	202 513	.. FITTING, hose brs barbed M 3/16 tbg x .250-20 (water)	2
.. 39	193 896	.. PIN, power assembly	1
.. 40	079 974	.. O-RING, .500 ID x .103 cs rbr	2

Item No.	Dia. Mkgs.	Part No.	Description	Quantity
Figure 8-6. Exploded View Of Pistol-Grip Gun (Continued)				
.. 41		202 216	.. GUIDE, wire outlet .030-1/16	1
.. 42		187 029	.. CONNECTOR, power/gas	1
.. 43		189 811	.. HOUSING, power pin LH	1
.. 44		133 083	.. SPRING, tension adj drive roll	1
.. 45		144 860	.. SCREW, mach stl flh 8-32 x .437	1
.. 46		058 968	.. RING, retainer E	2
.. 47		135 474	.. PIN, hinge	1
.. 48		155 565	.. SCREW, thumb	1
		134 799	.. O-RING, .176 ID x .070 CS (used w/thumb screw)	1
.. 49		135 126	.. SCREW, set stl sch 6-32 x .125 cup point	1
.. 50		170 353	.. PLUNGER, pin	1
.. 51		170 351	.. SPRING, cprsn .150 od x .01 wire x .375 lg	1
.. 52		170 352	.. PLUNGER, gas flow	1
.. 53		112 896	.. SPRING, cprsn .240 OD x .020 wire x .437	2
.. 54		135 773	.. KNOB, thumb tension adjusting 8-32	1
.. 55		143 360	.. SCREW, mach stl rdh 8-32 x .500	1
.. 56		136 679	.. CLAMP, strain relief	1
.. 57		132 269	.. SCREW, mach stl rdhph 8-32 x .375	1
.. 58		164 591	.. CASE, gun LH	1
.. 59		173 527	.. SCREW, 8-32 x 1.50 soc hd-hex gr 8	2
.. 60		173 528	.. SCREW, 8-32 x .875 soc hd-hex gr 8	1
.. 61	B2	161 813	.. MOTOR, gear PM 24VDC 420RPM 10.2:1 ratio	1
.. 62		191 121	.. SCREW, mach stl trh 6-32 x .250	2
.. 63		164 592	.. TRIGGER	1
.. 64		184 101	.. WASHER, shldr.140 id 0.250 od x .047 t .340 od x .078 t nyl	1
.. 65		058 262	.. CAP, valve	1
.. 66	R4	200 096	.. POTENTIOMETER, C sltd sft 1/T .5W 10K ohm	1
.. 67		144 861	.. WASHER, anti-turn	1
.. 68		135 127	.. LOCK, shaft pot .250-32 x .125dia shaft	1
.. 69		602 169	.. SCREW, set stl sch 8-32 x .187	2
.. 70		134 856	.. KNOB, speed control 1-10 .140 shaft x 1.125 OD	1
.. 71		164 590	.. CASE, gun RH	1
.. 72	PB1	000 369	.. SWITCH, lim 10A 125/250VAC DPST plgr	1
.. 73		183 884	.. SPRING, cprsn .240 OD x .026 wire x 1.000	1
.. 74		135 647	.. NUT, stl 8-32	3
.. 75		185 106	.. NUT, liner collet	1
		◆ 605 107	.. GREASE MINICAP	1
.. 76		203 557	.. CLAMP, 1-ear type	2

◆ Optional

To maintain the factory original performance of your equipment, use only Manufacturer's Suggested Replacement Parts. Model and serial number required when ordering parts from your local distributor.

☞ Hardware is common and not available unless listed.

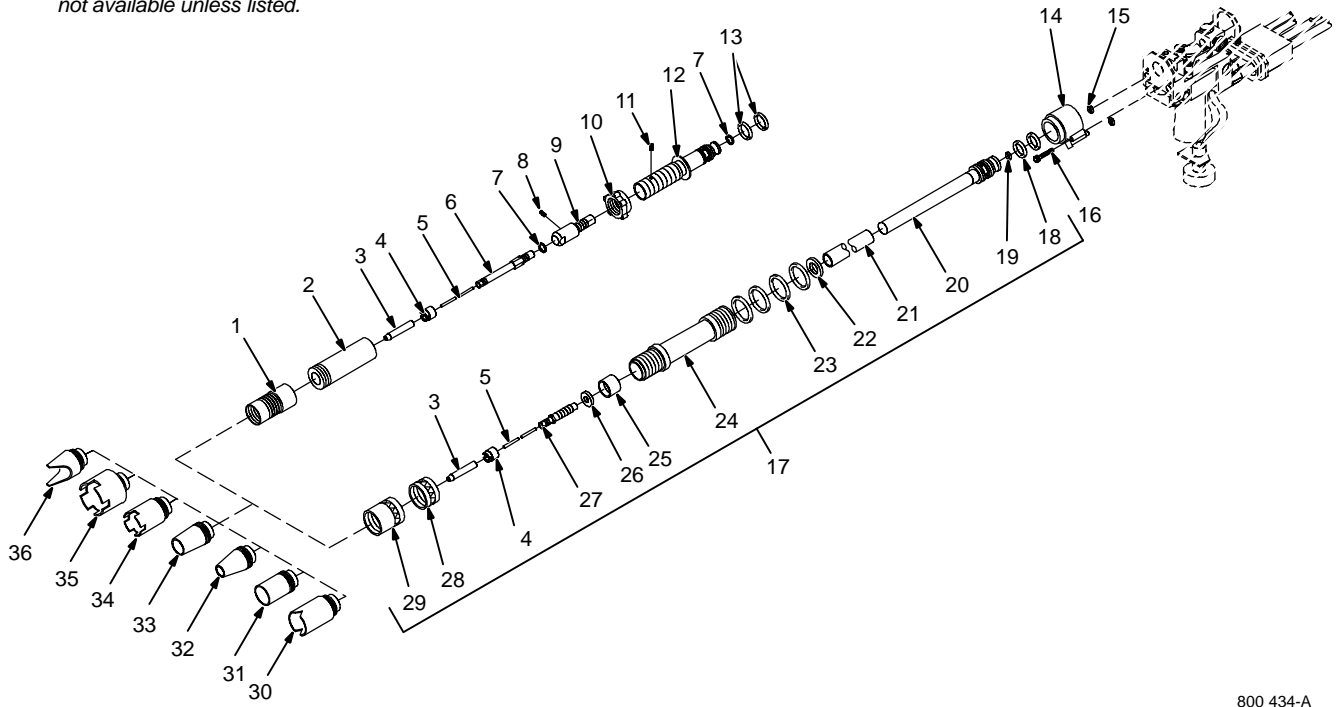

800 434-A

Figure 8-7. Barrel Assembly Of Pistol-Grip Gun

Item No.	Part No.	Description	Quantity
----------	----------	-------------	----------

Figure 8-7. Barrel Assembly Of Pistol-Grip Gun (Figure 8-6 Item 15)

.. 1	144 862	.. EXTENSION, nozzle (15A & 30A models)	1
.. 2	156 821	.. EXTENSION, barrel 2.875 lg (15A & 30A models)	1
.. 3	135 428	.. TUBE, contact .030/41 wire (Part of Wire Guide Kit 198 384)	1
.. 3	135 430	.. TUBE, contact .035/52 wire (Part of Wire Guide Kit 198 384)	1
.. 3	135 430	.. TUBE, contact .040/52 wire (Part of Wire Guide Kit 198 383)	1
.. 3	135 424	.. TUBE, contact .047/61 wire (Part of Wire Guide Kit 198 382)	1
.. 3	135 425	.. TUBE, contact .062/81 wire (Part of Wire Guide Kit 198 381)	1
.. 3	◆135 427	.. TUBE, contact .030/36 wire	1
.. 3	◆147 314	.. TUBE, contact .035/41 wire	1
.. 3	◆135 429	.. TUBE, contact .047/52 wire	1
.. 3	◆135 426	.. TUBE, contact .062/73 wire	1
..	136 821	.. WRENCH, nut tube contact	1
..	166 575	.. WRENCH, hex .078 across the flat	1
.. 4	136 748	.. NUT, collet	1
.. 5	◆◆136 683	.. LINER, teflon .045-1/16 wire x 6.875 lg	1
.. 5	◆◆◆136 682	.. LINER, teflon .023-.035 wire x 6.875 lg	1
.. 6	164 421	.. ADAPTER, contact tube (15A & 30A models)	1
.. 7	164 485	.. O-RING .176 ID x .070CS (15A & 30A models)	2
.. 8	604 612	.. SCREW, set stl sch 8-32 x .125 (15A & 30A models)	1
.. 9	164 422	.. TUBE, head (15A & 30A models)	1
.. 10	058 685	.. NUT, jam nozzle extension (15A & 30A models)	1
.. 11	602 172	.. SCREW, set stl sch 10-32 x .187 cup point (15A & 30A models)	1
.. 12	164 423	.. ADAPTER, tube head (15A & 30A models)	1
.. 13	134 800	.. O-RING, .614 ID x .070CS	2
.. 14	203 675	.. MANIFOLD, water (15W & 30W models) (consisting of)	1
.. 15	175 946	.. O-RING, .614 ID x .070CS	2
.. 16	135 128	.. SCREW, cap stl sch 6-32 x 1.000 (15W & 30W models)	2

Item No.	Part No.	Description	Quantity
Figure 8-7. Barrel Assembly Of Pistol-Grip Gun (Continued)			
.. 17	137 042	.. BARREL ASSEMBLY, water cooled (15W & 30W models) (consisting of)	1
.. 18	134 800	.. O-RING, .614 ID x .070CS	1
.. 19	134 799	.. O-RING, .176 ID x .070CS (15W & 30W models)	1
.. 20	180 805	.. FITTING ASSEMBLY, barrel	1
.. 21	136 943	.. TUBING, teflon	1
.. 22	136 834	.. WASHER, flat .594 ID fbr	1
.. 23	180 966	.. O-RING, .926 ID x .070CS	4
.. 24	137 041	.. BARREL, outer	1
.. 25	136 836	.. INSULATOR, head tube from adapter	1
.. 26	136 835	.. WASHER, flat .390 ID brs	1
.. 27	136 680	.. ADAPTER, contact tube	1
.. 28	136 833	.. NUT, 1.000-12 stl	1
.. 29	136 832	.. ADAPTER, nozzle	1
.. 30	◆009 925	.. NOZZLE, spot outside corner .937 ID x 2.375	1
.. 31	◆050 116	.. NOZZLE, 13/16 orf x 1-5/8 lg	1
.. 32	◆050 115	.. NOZZLE, 1/2 orf x 1-5/8 lg	1
.. 33	050 622	.. NOZZLE, 5/8 orf x 1-5/8 lg	1
.. 34	◆000 442	.. NOZZLE, spot	1
.. 35	◆004 466	.. NOZZLE, spot	1
.. 36	◆000 443	.. NOZZLE, spot inside corner	1

◆ Optional

◆◆ Part of 198 382 and 198 381 Wire Guide Kit Options

◆◆◆ Part of 198 384 and 198 383 Wire Guide Kit Options

To maintain the factory original performance of your equipment, use only Manufacturer's Suggested Replacement Parts. Model and serial number required when ordering parts from your local distributor.

TRUE BLUE[®]

WARRANTY

Effective January 1, 2002

(Equipment with a serial number preface of "LC" or newer)

This limited warranty supersedes all previous Miller warranties and is exclusive with no other guarantees or warranties expressed or implied.

Warranty Questions?

Call
1-800-4-A-MILLER
for your local
Miller distributor.

Your distributor also gives
you ...

Service

You always get the fast,
reliable response you
need. Most replacement
parts can be in your
hands in 24 hours.

Support

Need fast answers to the
tough welding questions?
Contact your distributor.
The expertise of the
distributor and Miller is
there to help you, every
step of the way.

LIMITED WARRANTY – Subject to the terms and conditions below, Miller Electric Mfg. Co., Appleton, Wisconsin, warrants to its original retail purchaser that new Miller equipment sold after the effective date of this limited warranty is free of defects in material and workmanship at the time it is shipped by Miller. THIS WARRANTY IS EXPRESSLY IN LIEU OF ALL OTHER WARRANTIES, EXPRESS OR IMPLIED, INCLUDING THE WARRANTIES OF MERCHANTABILITY AND FITNESS.

Within the warranty periods listed below, Miller will repair or replace any warranted parts or components that fail due to such defects in material or workmanship. Miller must be notified in writing within thirty (30) days of such defect or failure, at which time Miller will provide instructions on the warranty claim procedures to be followed.

Miller shall honor warranty claims on warranted equipment listed below in the event of such a failure within the warranty time periods. All warranty time periods start on the date that the equipment was delivered to the original retail purchaser, or one year after the equipment is sent to a North American distributor or eighteen months after the equipment is sent to an International distributor.

1. 5 Years Parts – 3 Years Labor
 - * Original main power rectifiers
 - * Inverters (input and output rectifiers only)
2. 3 Years — Parts and Labor
 - * Transformer/Rectifier Power Sources
 - * Plasma Arc Cutting Power Sources
 - * Semi-Automatic and Automatic Wire Feeders
 - * Inverter Power Supplies
 - * Intelligig
 - * Engine Driven Welding Generators
(NOTE: Engines are warranted separately by the engine manufacturer.)
3. 1 Year — Parts and Labor Unless Specified
 - * DS-2 Wire Feeder
 - * Motor Driven Guns (w/exception of Spoolmate Spoolguns)
 - * Process Controllers
 - * Positioners and Controllers
 - * Automatic Motion Devices
 - * RFCS Foot Controls
 - * Induction Heating Power Sources
 - * Water Coolant Systems
 - * Flowgauge and Flowmeter Regulators (No Labor)
 - * HF Units
 - * Grids
 - * Maxstar 85, 140
 - * Spot Welders
 - * Load Banks
 - * Racks
 - * Running Gear/Trailers
 - * Plasma Cutting Torches (except APT & SAF Models)
 - * Field Options
(NOTE: Field options are covered under True Blue[®] for the remaining warranty period of the product they are installed in, or for a minimum of one year — whichever is greater.)
4. 6 Months — Batteries
5. 90 Days — Parts
 - * MIG Guns/TIG Torches
 - * Induction Heating Coils and Blankets

- * APT, ZIPCUT & PLAZCUT Model Plasma Cutting Torches
- * Remote Controls
- * Accessory Kits
- * Replacement Parts (No labor)
- * Spoolmate Spoolguns
- * Canvas Covers

Miller's True Blue[®] Limited Warranty shall not apply to:

1. **Consumable components; such as contact tips, cutting nozzles, contactors, brushes, slip rings, relays or parts that fail due to normal wear. (Exception: brushes, slip rings, and relays are covered on Bobcat, Trailblazer, and Legend models.)**
2. Items furnished by Miller, but manufactured by others, such as engines or trade accessories. These items are covered by the manufacturer's warranty, if any.
3. Equipment that has been modified by any party other than Miller, or equipment that has been improperly installed, improperly operated or misused based upon industry standards, or equipment which has not had reasonable and necessary maintenance, or equipment which has been used for operation outside of the specifications for the equipment.

MILLER PRODUCTS ARE INTENDED FOR PURCHASE AND USE BY COMMERCIAL/INDUSTRIAL USERS AND PERSONS TRAINED AND EXPERIENCED IN THE USE AND MAINTENANCE OF WELDING EQUIPMENT.

In the event of a warranty claim covered by this warranty, the exclusive remedies shall be, at Miller's option: (1) repair; or (2) replacement; or, where authorized in writing by Miller in appropriate cases, (3) the reasonable cost of repair or replacement at an authorized Miller service station; or (4) payment of or credit for the purchase price (less reasonable depreciation based upon actual use) upon return of the goods at customer's risk and expense. Miller's option of repair or replacement will be F.O.B., Factory at Appleton, Wisconsin, or F.O.B. at a Miller authorized service facility as determined by Miller. Therefore no compensation or reimbursement for transportation costs of any kind will be allowed.

TO THE EXTENT PERMITTED BY LAW, THE REMEDIES PROVIDED HEREIN ARE THE SOLE AND EXCLUSIVE REMEDIES. IN NO EVENT SHALL MILLER BE LIABLE FOR DIRECT, INDIRECT, SPECIAL, INCIDENTAL OR CONSEQUENTIAL DAMAGES (INCLUDING LOSS OF PROFIT), WHETHER BASED ON CONTRACT, TORT OR ANY OTHER LEGAL THEORY.

ANY EXPRESS WARRANTY NOT PROVIDED HEREIN AND ANY IMPLIED WARRANTY, GUARANTY OR REPRESENTATION AS TO PERFORMANCE, AND ANY REMEDY FOR BREACH OF CONTRACT TORT OR ANY OTHER LEGAL THEORY WHICH, BUT FOR THIS PROVISION, MIGHT ARISE BY IMPLICATION, OPERATION OF LAW, CUSTOM OF TRADE OR COURSE OF DEALING, INCLUDING ANY IMPLIED WARRANTY OF MERCHANTABILITY OR FITNESS FOR PARTICULAR PURPOSE, WITH RESPECT TO ANY AND ALL EQUIPMENT FURNISHED BY MILLER IS EXCLUDED AND DISCLAIMED BY MILLER.

Some states in the U.S.A. do not allow limitations of how long an implied warranty lasts, or the exclusion of incidental, indirect, special or consequential damages, so the above limitation or exclusion may not apply to you. This warranty provides specific legal rights, and other rights may be available, but may vary from state to state.

In Canada, legislation in some provinces provides for certain additional warranties or remedies other than as stated herein, and to the extent that they may not be waived, the limitations and exclusions set out above may not apply. This Limited Warranty provides specific legal rights, and other rights may be available, but may vary from province to province.





Owner's Record

Please complete and retain with your personal records.

Model Name Serial/Style Number

Purchase Date (Date which equipment was delivered to original customer.)

Distributor

Address

City

State Zip



For Service

Call 1-800-4-A-Miller or see our website at www.MillerWelds.com to locate a DISTRIBUTOR or SERVICE AGENCY near you.

Always provide Model Name and Serial/Style Number.

Contact your Distributor for:

- Welding Supplies and Consumables
- Options and Accessories
- Personal Safety Equipment
- Service and Repair
- Replacement Parts
- Training (Schools, Videos, Books)
- Technical Manuals (Servicing Information and Parts)
- Circuit Diagrams
- Welding Process Handbooks

Contact the Delivering Carrier for:

File a claim for loss or damage during shipment.

For assistance in filing or settling claims, contact your distributor and/or equipment manufacturer's Transportation Department.

Miller Electric Mfg. Co.

An Illinois Tool Works Company
1635 West Spencer Street
Appleton, WI 54914 USA

International Headquarters—USA

USA Phone: 920-735-4505 Auto-Attended
USA & Canada FAX: 920-735-4134
International FAX: 920-735-4125

European Headquarters – United Kingdom

Phone: 44 (0) 1204-593493
FAX: 44 (0) 1204-598066

www.MillerWelds.com

