



OM-133 929R

July 1999

Processes



Stick (SMAW) Welding



Air Carbon Arc (CAC-A)
Cutting and Gouging

With Optional Equipment:



MIG (GMAW) Welding

Flux Cored (FCAW) Welding

Description



Engine Driven Welding Generator

Big Blue[®] 600DX

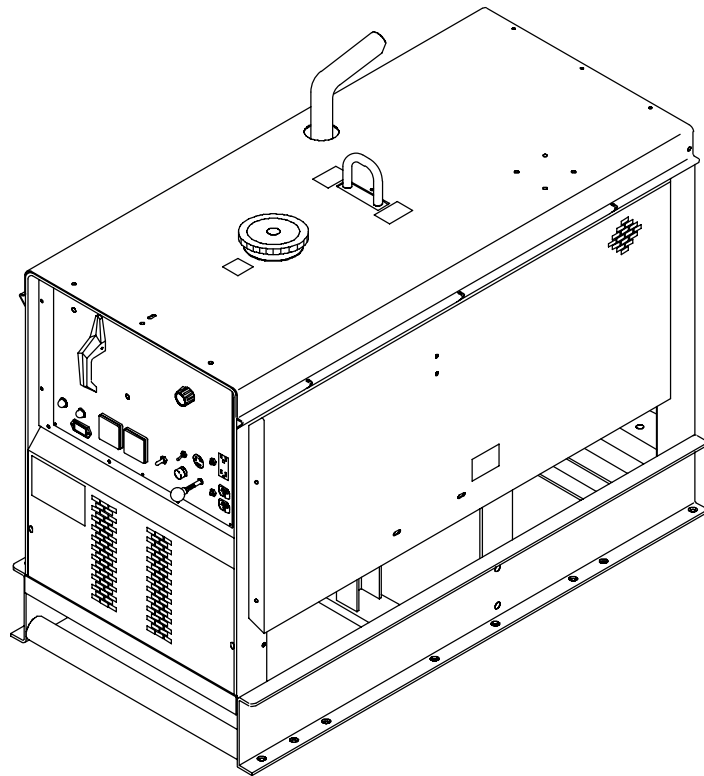

OWNER'S MANUAL



Visit our website at
www.MillerWelds.com

From Miller to You

Thank you and congratulations on choosing Miller. Now you can get the job done and get it done right. We know you don't have time to do it any other way.

That's why when Niels Miller first started building arc welders in 1929, he made sure his products offered long-lasting value and superior quality. Like you, his customers couldn't afford anything less. Miller products had to be more than the best they could be. They had to be the best you could buy.

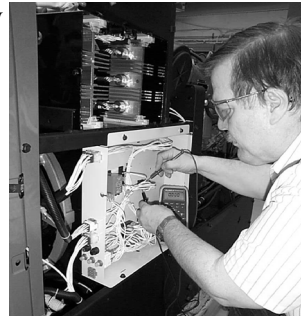

Today, the people that build and sell Miller products continue the tradition. They're just as committed to providing equipment and service that meets the high standards of quality and value established in 1929.

This Owner's Manual is designed to help you get the most out of your Miller products. Please take time to read the Safety precautions. They will help you protect yourself against potential hazards on the worksite. We've



Miller is the first welding equipment manufacturer in the U.S.A. to be registered to the ISO 9001 Quality System Standard.

made installation and operation quick and easy. With Miller you can count on years of reliable service with proper maintenance. And if for some reason the unit needs repair, there's a Troubleshooting section that will help you figure out what the problem is. The parts list will then help you to decide which exact part you may need to fix the problem. Warranty and service information for your particular model are also provided.

Miller Electric manufactures a full line of welders and welding related equipment. For information on other quality Miller products, contact your local Miller distributor to receive the latest full line catalog or individual catalog sheets. To locate your nearest distributor call 1-800-4-A-Miller.



Working as hard as you do - every power source from Miller is backed by the most hassle-free warranty in the business.

Miller offers a Technical Manual which provides more detailed service and parts information for your unit. To obtain a Technical Manual, contact your local distributor. Your distributor can also supply you with Welding Process Manuals such as SMAW, GTAW, GMAW, and GMAW-P.



TABLE OF CONTENTS

WARNING

This product, when used for welding or cutting, produces fumes or gases which contain chemicals known to the State of California to cause birth defects and, in some cases, cancer. (California Health & Safety Code Section 25249.5 et seq.)

WARNING

Battery posts, terminals and related accessories contain lead and lead compounds, chemicals known to the State of California to cause cancer and birth defects or other reproductive harm. Wash hands after handling.

CALIFORNIA

Proposition 65 Warning

Diesel engine exhaust and some of its constituents are known to the State of California to cause cancer, birth defects, and other reproductive harm.

The following terms are used interchangeably throughout this manual:
TIG = GTAW
Stick = SMAW

SECTION 1 – SAFETY PRECAUTIONS - READ BEFORE USING	1
1-1. Symbol Usage	1
1-2. Arc Welding Hazards	1
1-3. Engine Hazards	2
1-4. Additional Symbols For Installation, Operation, And Maintenance	3
1-5. Principal Safety Standards	4
1-6. EMF Information	4
SECTION 1 – CONSIGNES DE SÉCURITÉ – LIRE AVANT UTILISATION	5
1-1. Signification des symboles	5
1-2. Dangers relatifs au soudage à l'arc	5
1-3. Dangers existant en relation avec le moteur	6
1-4. Dangers supplémentaires en relation avec l'installation, le fonctionnement et la maintenance	7
1-5. Principales normes de sécurité	8
1-6. Information sur les champs électromagnétiques	8
SECTION 2 – DEFINITIONS	9
2-1. Symbols And Definitions	9
SECTION 3 – SPECIFICATIONS	9
3-1. Specifications	9
3-2. Dimensions, Weights, And Operating Angles	10
3-3. Fuel Consumption	10
3-4. Duty Cycle And Overheating	11
3-5. AC Auxiliary Power	11
3-6. Volt-Ampere Curves	12
3-7. Optional AC Power Plant Curves	13
SECTION 4 – INSTALLATION	14
4-1. Installing Welding Generator	14
4-2. Installing Exhaust Pipe	14
4-3. Activating The Dry Charge Battery	15
4-4. Connecting The Battery	16
4-5. Engine Prestart Checks	16
4-6. Connecting To Weld Output Terminals	17
4-7. Selecting Weld Cable Sizes	17
4-8. Installing Ether Cylinder (Optional Ether Starting Aid)	18
4-9. Remote A/V Control Receptacle RC3	18
4-10. Remote 14 Receptacle RC3 Information (Optional)	19
4-11. Terminal Strip 2T Connections (Optional)	19
SECTION 5 – OPERATING THE WELDING GENERATOR	20
5-1. Standard Controls (See Section 5-2)	20
5-2. Description Of Standard Controls (See Section 5-1)	21
5-3. Controls For Models With CV Option (See Section 5-4)	22
5-4. Description Of Controls For Models With CV Option (See Section 5-3)	23
SECTION 6 – OPERATING AUXILIARY EQUIPMENT	24
6-1. 120 Volt And 240 Volt Duplex Receptacles	24
6-2. Optional Auxiliary Power Receptacles	25
6-3. Connecting Optional Auxiliary Power Plant	26
SECTION 7 – MAINTENANCE & TROUBLESHOOTING	27
7-1. Routine Maintenance	27
7-2. Maintenance Label	28
7-3. Servicing Air Cleaner	29
7-4. Servicing Fuel And Lubrication Systems	30
7-5. Adjusting Engine Speed	31
7-6. Servicing Optional Ether Starting Aid	31
7-7. Checking And Replacing Alternator Belt	32
7-8. Resetting Fan Belt Safety Shutdown	33
7-9. Inspecting And Cleaning Optional Spark Arrestor Muffler	34
7-10. Overload Protection For Models With CV Option	34
7-11. Troubleshooting	35
SECTION 8 – ELECTRICAL DIAGRAMS	37
SECTION 9 – RUN-IN PROCEDURE	40
9-1. Wetstacking	40
9-2. Run-In Procedure Using Load Bank	41
9-3. Run-In Procedure Using Resistance Grid	42
SECTION 10 – AUXILIARY POWER GUIDELINES	43
SECTION 10 – PARTS LIST	50
WARRANTY	

SECTION 1 – SAFETY PRECAUTIONS - READ BEFORE USING

rom_nd_11/98

1-1. Symbol Usage



Means Warning! Watch Out! There are possible hazards with this procedure! The possible hazards are shown in the adjoining symbols.

▲ Marks a special safety message.

☞ Means "Note"; not safety related.



This group of symbols means Warning! Watch Out! possible ELECTRIC SHOCK, MOVING PARTS, and HOT PARTS hazards. Consult symbols and related instructions below for necessary actions to avoid the hazards.

1-2. Arc Welding Hazards

▲ The symbols shown below are used throughout this manual to call attention to and identify possible hazards. When you see the symbol, watch out, and follow the related instructions to avoid the hazard. The safety information given below is only a summary of the more complete safety information found in the Safety Standards listed in Section 1-5. Read and follow all Safety Standards.

▲ Only qualified persons should install, operate, maintain, and repair this unit.

▲ During operation, keep everybody, especially children, away.



ELECTRIC SHOCK can kill.

Touching live electrical parts can cause fatal shocks or severe burns. The electrode and work circuit is electrically live whenever the output is on. The input power circuit and machine internal circuits are also live when power is on. In semiautomatic or automatic wire welding, the wire, wire reel, drive roll housing, and all metal parts touching the welding wire are electrically live. Incorrectly installed or improperly grounded equipment is a hazard.

- Do not touch live electrical parts.
- Wear dry, hole-free insulating gloves and body protection.
- Insulate yourself from work and ground using dry insulating mats or covers big enough to prevent any physical contact with the work or ground.
- Do not use AC output in damp areas, if movement is confined, or if there is a danger of falling.
- Use AC output ONLY if required for the welding process.
- If AC output is required, use remote output control if present on unit.
- Disconnect input power or stop engine before installing or servicing this equipment. Lockout/tagout input power according to OSHA 29 CFR 1910.147 (see Safety Standards).
- Properly install and ground this equipment according to its Owner's Manual and national, state, and local codes.
- Always verify the supply ground – check and be sure that input power cord ground wire is properly connected to ground terminal in disconnect box or that cord plug is connected to a properly grounded receptacle outlet.
- When making input connections, attach proper grounding conductor first – double-check connections.
- Frequently inspect input power cord for damage or bare wiring – replace cord immediately if damaged – bare wiring can kill.
- Turn off all equipment when not in use.
- Do not use worn, damaged, undersized, or poorly spliced cables.
- Do not drape cables over your body.
- If earth grounding of the workpiece is required, ground it directly with a separate cable.
- Do not touch electrode if you are in contact with the work, ground, or another electrode from a different machine.
- Use only well-maintained equipment. Repair or replace damaged parts at once. Maintain unit according to manual.

- Wear a safety harness if working above floor level.
- Keep all panels and covers securely in place.
- Clamp work cable with good metal-to-metal contact to workpiece or worktable as near the weld as practical.
- Insulate work clamp when not connected to workpiece to prevent contact with any metal object.
- Do not connect more than one electrode or work cable to any single weld output terminal.

SIGNIFICANT DC VOLTAGE exists after stopping engine on inverters.

- Stop engine on inverter and discharge input capacitors according to instructions in Maintenance Section before touching any parts.

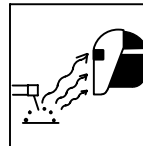

ARC RAYS can burn eyes and skin.

Arc rays from the welding process produce intense visible and invisible (ultraviolet and infrared) rays that can burn eyes and skin. Sparks fly off from the weld.

- Wear a welding helmet fitted with a proper shade of filter to protect your face and eyes from arc rays and sparks when welding or watching (see ANSI Z49.1 and Z87.1 listed in Safety Standards).
- Wear approved safety glasses with side shields under your helmet.
- Use protective screens or barriers to protect others from flash and glare; warn others not to watch the arc.
- Wear protective clothing made from durable, flame-resistant material (wool and leather) and foot protection.

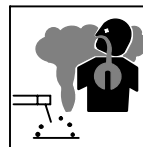

FUMES AND GASES can be hazardous.

Welding produces fumes and gases. Breathing these fumes and gases can be hazardous to your health.

- Keep your head out of the fumes. Do not breathe the fumes.
- If inside, ventilate the area and/or use exhaust at the arc to remove welding fumes and gases.
- If ventilation is poor, use an approved air-supplied respirator.
- Read the Material Safety Data Sheets (MSDSs) and the manufacturer's instructions for metals, consumables, coatings, cleaners, and degreasers.
- Work in a confined space only if it is well ventilated, or while wearing an air-supplied respirator. Always have a trained watch-person nearby. Welding fumes and gases can displace air and lower the oxygen level causing injury or death. Be sure the breathing air is safe.
- Do not weld in locations near degreasing, cleaning, or spraying operations. The heat and rays of the arc can react with vapors to form highly toxic and irritating gases.
- Do not weld on coated metals, such as galvanized, lead, or cadmium plated steel, unless the coating is removed from the weld area, the area is well ventilated, and if necessary, while wearing an air-supplied respirator. The coatings and any metals containing these elements can give off toxic fumes if welded.

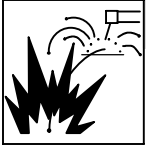

WELDING can cause fire or explosion.

Welding on closed containers, such as tanks, drums, or pipes, can cause them to blow up. Sparks can fly off from the welding arc. The flying sparks, hot workpiece, and hot equipment can cause fires and burns. Accidental contact of electrode to metal objects can cause sparks, explosion, overheating, or fire. Check and be sure the area is safe before doing any welding.

- Protect yourself and others from flying sparks and hot metal.
- Do not weld where flying sparks can strike flammable material.
- Remove all flammables within 35 ft (10.7 m) of the welding arc. If this is not possible, tightly cover them with approved covers.
- Be alert that welding sparks and hot materials from welding can easily go through small cracks and openings to adjacent areas.
- Watch for fire, and keep a fire extinguisher nearby.
- Be aware that welding on a ceiling, floor, bulkhead, or partition can cause fire on the hidden side.
- Do not weld on closed containers such as tanks, drums, or pipes, unless they are properly prepared according to AWS F4.1 (see Safety Standards).
- Connect work cable to the work as close to the welding area as practical to prevent welding current from traveling long, possibly unknown paths and causing electric shock and fire hazards.
- Do not use welder to thaw frozen pipes.
- Remove stick electrode from holder or cut off welding wire at contact tip when not in use.
- Wear oil-free protective garments such as leather gloves, heavy shirt, cuffless trousers, high shoes, and a cap.
- Remove any combustibles, such as a butane lighter or matches, from your person before doing any welding.

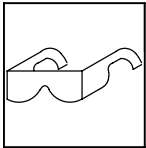

FLYING METAL can injure eyes.

- Welding, chipping, wire brushing, and grinding cause sparks and flying metal. As welds cool, they can throw off slag.
- Wear approved safety glasses with side shields even under your welding helmet.



BUILDUP OF GAS can injure or kill.

- Shut off shielding gas supply when not in use.
- Always ventilate confined spaces or use approved air-supplied respirator.

1-3. Engine Hazards



FUEL can cause fire or explosion.

- Stop engine and let it cool off before checking or adding fuel.
- Do not add fuel while smoking or if unit is near any sparks or open flames.

- Do not overfill tank – allow room for fuel to expand.
- Do not spill fuel. If fuel is spilled, clean up before starting engine.
- Dispose of rags in a fireproof container.



HOT PARTS can cause severe burns.

- Allow cooling period before maintaining.
- Wear protective gloves and clothing when working on a hot engine.
- Do not touch hot engine parts or just-welded parts bare-handed.

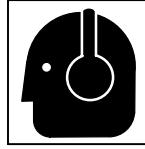

NOISE can damage hearing.

Noise from some processes or equipment can damage hearing.

- Wear approved ear protection if noise level is high.

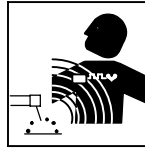

MAGNETIC FIELDS can affect pacemakers.

- Pacemaker wearers keep away.
- Wearers should consult their doctor before going near arc welding, gouging, or spot welding operations.

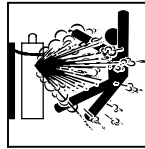

CYLINDERS can explode if damaged.

Shielding gas cylinders contain gas under high pressure. If damaged, a cylinder can explode. Since gas cylinders are normally part of the welding process, be sure to treat them carefully.

- Protect compressed gas cylinders from excessive heat, mechanical shocks, slag, open flames, sparks, and arcs.
- Install cylinders in an upright position by securing to a stationary support or cylinder rack to prevent falling or tipping.
- Keep cylinders away from any welding or other electrical circuits.
- Never drape a welding torch over a gas cylinder.
- Never allow a welding electrode to touch any cylinder.
- Never weld on a pressurized cylinder – explosion will result.
- Use only correct shielding gas cylinders, regulators, hoses, and fittings designed for the specific application; maintain them and associated parts in good condition.
- Turn face away from valve outlet when opening cylinder valve.
- Keep protective cap in place over valve except when cylinder is in use or connected for use.
- Read and follow instructions on compressed gas cylinders, associated equipment, and CGA publication P-1 listed in Safety Standards.

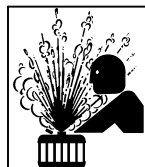

STEAM AND HOT COOLANT can burn.

- If possible, check coolant level when engine is cold to avoid scalding.
- Always check coolant level at overflow tank, if present on unit, instead of radiator (unless told otherwise in maintenance section or engine manual).
- If the engine is warm, checking is needed, and there is no overflow tank, follow the next two statements.
- Wear safety glasses and gloves and put a rag over radiator cap.
- Turn cap slightly and let pressure escape slowly before completely removing cap.



MOVING PARTS can cause injury.

- Keep away from fans, belts, and rotors.
- Keep all doors, panels, covers, and guards closed and securely in place.
- Stop engine before installing or connecting unit.
- Have only qualified people remove guards or covers for maintenance and troubleshooting as necessary.
- To prevent accidental starting during servicing, disconnect negative (-) battery cable from battery.
- Keep hands, hair, loose clothing, and tools away from moving parts.
- Reinstall panels or guards and close doors when servicing is finished and before starting engine.
- Before working on generator, remove spark plugs or injectors to keep engine from kicking back or starting.
- Block flywheel so that it will not turn while working on generator components.

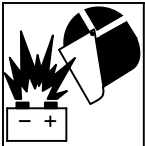

BATTERY EXPLOSION can BLIND.

- Always wear a face shield, rubber gloves, and protective clothing when working on a battery.
- Stop engine before disconnecting or connecting battery cables or servicing battery.
- Do not allow tools to cause sparks when working on a battery.
- Do not use welder to charge batteries or jump start vehicles.
- Observe correct polarity (+ and -) on batteries.
- Disconnect negative (-) cable first and connect it last.

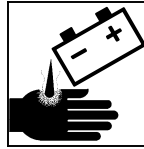

BATTERY ACID can BURN SKIN and EYES.

- Do not tip battery.
- Replace damaged battery.
- Flush eyes and skin immediately with water.

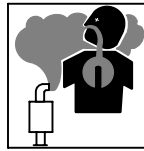

ENGINE EXHAUST GASES can kill.

- Use equipment outside in open, well-ventilated areas.
- If used in a closed area, vent engine exhaust outside and away from any building air intakes.



ENGINE HEAT can cause fire.

- Do not locate unit on, over, or near combustible surfaces or flammables.
- Keep exhaust and exhaust pipes way from flammables.



EXHAUST SPARKS can cause fire.

- Do not let engine exhaust sparks cause fire.
- Use approved engine exhaust spark arrestor in required areas – see applicable codes.

1-4. Additional Symbols For Installation, Operation, And Maintenance



FALLING UNIT can cause injury.

- Use lifting eye to lift unit only, NOT running gear, gas cylinders, trailer, or any other accessories.
- Use equipment of adequate capacity to lift and support unit.
- If using lift forks to move unit, be sure forks are long enough to extend beyond opposite side of unit.

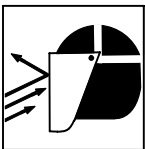

FLYING SPARKS can cause injury.

- Wear a face shield to protect eyes and face.
- Shape tungsten electrode only on grinder with proper guards in a safe location wearing proper face, hand, and body protection.
- Sparks can cause fires — keep flammables away.

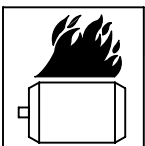

OVERHEATING can damage motors.

- Turn off or unplug equipment before starting or stopping engine.
- Do not let low voltage and frequency caused by low engine speed damage electric motors.
- Do not connect 50 or 60 Hertz motors to the 100 Hertz receptacle where applicable.

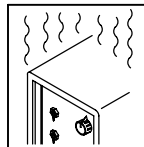

OVERUSE can cause OVERHEATING.

- Allow cooling period; follow rated duty cycle.
- Reduce current or reduce duty cycle before starting to weld again.
- Do not block or filter airflow to unit.

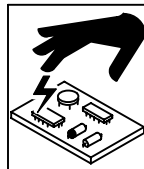

STATIC (ESD) can damage PC boards.

- Put on grounded wrist strap BEFORE handling boards or parts.
- Use proper static-proof bags and boxes to store, move, or ship PC boards.

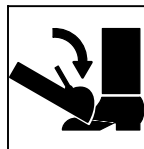

TILTING OF TRAILER can cause injury.

- Use tongue jack or blocks to support weight.
- Properly install welding generator onto trailer according to instructions supplied with trailer.

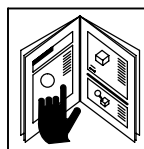

READ INSTRUCTIONS.

- Use only genuine MILLER replacement parts.
- Perform engine maintenance and service according to this manual and the engine manual.

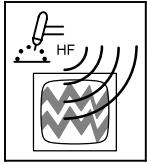

H.F. RADIATION can cause interference.

- High-frequency (H.F.) can interfere with radio navigation, safety services, computers, and communications equipment.
- Have only qualified persons familiar with electronic equipment perform this installation.
- The user is responsible for having a qualified electrician promptly correct any interference problem resulting from the installation.
- If notified by the FCC about interference, stop using the equipment at once.
- Have the installation regularly checked and maintained.
- Keep high-frequency source doors and panels tightly shut, keep spark gaps at correct setting, and use grounding and shielding to minimize the possibility of interference.

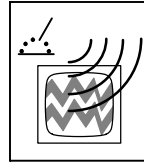

ARC WELDING can cause interference.

- Electromagnetic energy can interfere with sensitive electronic equipment such as computers and computer-driven equipment such as robots.
- Be sure all equipment in the welding area is electromagnetically compatible.
- To reduce possible interference, keep weld cables as short as possible, close together, and down low, such as on the floor.
- Locate welding operation 100 meters from any sensitive electronic equipment.
- Be sure this welding machine is installed and grounded according to this manual.
- If interference still occurs, the user must take extra measures such as moving the welding machine, using shielded cables, using line filters, or shielding the work area.

1-5. Principal Safety Standards

Safety in Welding and Cutting, ANSI Standard Z49.1, from American Welding Society, 550 N.W. LeJeune Rd, Miami FL 33126

Safety and Health Standards, OSHA 29 CFR 1910, from Superintendent of Documents, U.S. Government Printing Office, Washington, D.C. 20402.

Recommended Safe Practices for the Preparation for Welding and Cutting of Containers That Have Held Hazardous Substances, American Welding Society Standard AWS F4.1, from American Welding Society, 550 N.W. LeJeune Rd, Miami, FL 33126

National Electrical Code, NFPA Standard 70, from National Fire Protection Association, Batterymarch Park, Quincy, MA 02269.

Safe Handling of Compressed Gases in Cylinders, CGA Pamphlet P-1, from Compressed Gas Association, 1235 Jefferson Davis Highway, Suite 501, Arlington, VA 22202.

Code for Safety in Welding and Cutting, CSA Standard W117.2, from Canadian Standards Association, Standards Sales, 178 Rexdale Boulevard, Rexdale, Ontario, Canada M9W 1R3.

Safe Practices For Occupation And Educational Eye And Face Protection, ANSI Standard Z87.1, from American National Standards Institute, 1430 Broadway, New York, NY 10018.

Cutting And Welding Processes, NFPA Standard 51B, from National Fire Protection Association, Batterymarch Park, Quincy, MA 02269.

1-6. EMF Information

Considerations About Welding And The Effects Of Low Frequency Electric And Magnetic Fields

Welding current, as it flows through welding cables, will cause electromagnetic fields. There has been and still is some concern about such fields. However, after examining more than 500 studies spanning 17 years of research, a special blue ribbon committee of the National Research Council concluded that: "The body of evidence, in the committee's judgment, has not demonstrated that exposure to power-frequency electric and magnetic fields is a human-health hazard." However, studies are still going forth and evidence continues to be examined. Until the final conclusions of the research are reached, you may wish to minimize your exposure to electromagnetic fields when welding or cutting.

To reduce magnetic fields in the workplace, use the following procedures:

1. Keep cables close together by twisting or taping them.
2. Arrange cables to one side and away from the operator.
3. Do not coil or drape cables around your body.
4. Keep welding power source and cables as far away from operator as practical.
5. Connect work clamp to workpiece as close to the weld as possible.

About Pacemakers:

Pacemaker wearers consult your doctor first. If cleared by your doctor, then following the above procedures is recommended.

SECTION 1 – CONSIGNES DE SÉCURITÉ – LIRE AVANT UTILISATION

rom_nd_fre 5/97

1-1. Signification des symboles



Signifie Mise en garde ! Soyez vigilant ! Cette procédure présente des risques de danger ! Ceux-ci sont identifiés par des symboles adjacents aux directives.

▲ Identifie un message de sécurité particulier.

Signifie NOTA ; n'est pas relatif à la sécurité.



Ce groupe de symboles signifie Mise en garde ! Soyez vigilant ! Il y a des risques de danger reliés aux CHOCS ÉLECTRIQUES, aux PIÈCES EN MOUVEMENT et aux PIÈCES CHAUDES. Reportez-vous aux symboles et aux directives ci-dessous afin de connaître les mesures à prendre pour éviter tout danger.

1-2. Dangers relatifs au soudage à l'arc

▲ Les symboles présentés ci-après sont utilisés tout au long du présent manuel pour attirer votre attention et identifier les risques de danger. Lorsque vous voyez un symbole, soyez vigilant et suivez les directives mentionnées afin d'éviter tout danger. Les consignes de sécurité présentées ci-après ne font que résumer l'information contenue dans les normes de sécurité énumérées à la section 1-5. Veuillez lire et respecter toutes ces normes de sécurité.

▲ L'installation, l'utilisation, l'entretien et les réparations ne doivent être confiés qu'à des personnes qualifiées.

▲ Au cours de l'utilisation, tenir toute personne à l'écart et plus particulièrement les enfants.



UN CHOC ÉLECTRIQUE peut tuer.

Un simple contact avec des pièces électriques peut provoquer une électrocution ou des blessures graves. L'électrode et le circuit de soudage sont sous tension dès que l'appareil est sur ON. Le circuit d'entrée et les circuits internes de l'appareil sont également sous tension à ce moment-là. En soudage semi-automatique ou automatique, le fil, le dévidoir, le logement des galets d'entraînement et les pièces métalliques en contact avec le fil de soudage sont sous tension. Des matériels mal installés ou mal mis à la terre présentent un danger.

- Ne jamais toucher les pièces électriques sous tension.
- Porter des gants et des vêtements de protection secs ne comportant pas de trous.
- S'isoler de la pièce et de la terre au moyen de tapis ou d'autres moyens isolants suffisamment grands pour empêcher le contact physique éventuel avec la pièce ou la terre.
- Ne pas se servir de source électrique à courant électrique dans les zones humides, dans les endroits confinés ou là où on risque de tomber.
- Se servir d'une source électrique à courant électrique UNIQUEMENT si le procédé de soudage le demande.
- Si l'utilisation d'une source électrique à courant électrique s'avère nécessaire, se servir de la fonction de télécommande si l'appareil en est équipé.
- Couper l'alimentation ou arrêter le moteur avant de procéder à l'installation, à la réparation ou à l'entretien de l'appareil. Déverrouiller l'alimentation selon la norme OSHA 29 CFR 1910.147 (voir normes de sécurité).
- Installer et mettre à la terre correctement cet appareil conformément à son manuel d'utilisation et aux codes nationaux, provinciaux et municipaux.
- Toujours vérifier la terre du cordon d'alimentation – Vérifier et s'assurer que le fil de terre du cordon d'alimentation est bien raccordé à la borne de terre du sectionneur ou que la fiche du cordon est raccordée à une prise correctement mise à la terre.
- En effectuant les raccordements d'entrée fixer d'abord le conducteur de mise à la terre approprié et contre-vérifier les connexions.
- Vérifier fréquemment le cordon d'alimentation pour voir s'il n'est pas endommagé ou dénudé – remplacer le cordon immédiatement s'il est endommagé – un câble dénudé peut provoquer une électrocution.
- Mettre l'appareil hors tension quand on ne l'utilise pas.
- Ne pas utiliser des câbles usés, endommagés, de grosseur insuffisante ou mal épluchés.
- Ne pas enrouler les câbles autour du corps.
- Si la pièce soudée doit être mise à la terre, le faire directement avec un câble distinct – ne pas utiliser le connecteur de pièce ou le câble de retour.

- Ne pas toucher l'électrode quand on est en contact avec la pièce, la terre ou une électrode provenant d'une autre machine.
- N'utiliser qu'un matériel en bon état. Réparer ou remplacer sur-le-champ les pièces endommagées. Entretien l'appareil conformément à ce manuel.
- Porter un harnais de sécurité quand on travaille en hauteur.
- Maintenir solidement en place tous les panneaux et capots.
- Fixer le câble de retour de façon à obtenir un bon contact métal-métal avec la pièce à souder ou la table de travail, le plus près possible de la soudure.
- Isoler la pince de masse quand pas mis à la pièce pour éviter le contact avec tout objet métallique.

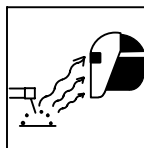

LES RAYONS DE L'ARC peuvent provoquer des brûlures dans les yeux et sur la peau.

Le rayonnement de l'arc du procédé de soudage génère des rayons visibles et invisibles intenses (ultraviolets et infrarouges) susceptibles de provoquer des brûlures dans les yeux et sur la peau. Des étincelles sont projetées pendant le soudage.

- Porter un casque de soudage muni d'un écran de filtre approprié pour protéger votre visage et vos yeux pendant le soudage ou pour regarder (voir ANSI Z49.1 et Z87.1 énuméré dans les normes de sécurité).
- Porter des protections approuvés pour les oreilles si le niveau sonore est trop élevé.
- Utiliser des écrans ou des barrières pour protéger des tiers de l'éclair et de l'éblouissement; demander aux autres personnes de ne pas regarder l'arc.
- Porter des vêtements de protection constitué dans une matière durable, résistant au feu (laine ou cuir) et une protection des pieds.

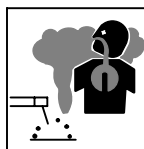

LES FUMÉES ET LES GAZ peuvent être dangereux.

Le soudage génère des fumées et des gaz. Leur inhalation peut être dangereux pour votre santé.

- Eloigner votre tête des fumées. Ne pas respirer les fumées.
- À l'intérieur, ventiler la zone et/ou utiliser un échappement au niveau de l'arc pour l'évacuation des fumées et des gaz de soudage.
- Si la ventilation est insuffisante, utiliser un respirateur à alimentation d'air homologué.
- Lire les spécifications de sécurité des matériaux (MSDSs) et les instructions du fabricant concernant les métaux, les consommables, les revêtements, les nettoyants et les dégraisseurs.
- Travailler dans un espace fermé seulement s'il est bien ventilé ou en portant un respirateur à alimentation d'air. Demander toujours à un surveillant dûment formé de se tenir à proximité. Des fumées et des gaz de soudage peuvent déplacer l'air et abaisser le niveau d'oxygène provoquant des blessures ou des accidents mortels. S'assurer que l'air de respiration ne présente aucun danger.
- Ne pas souder dans des endroits situés à proximité d'opérations de dégraissage, de nettoyage ou de pulvérisation. La chaleur et les rayons de l'arc peuvent réagir en présence de vapeurs et former des gaz hautement toxiques et irritants.
- Ne pas souder des métaux munis d'un revêtement, tels que l'acier galvanisé, plaqué en plomb ou au cadmium à moins que le revêtement n'ait été enlevé dans la zone de soudure, que l'endroit soit bien ventilé, et si nécessaire, en portant un respirateur à alimentation d'air. Les revêtements et tous les métaux renfermant ces éléments peuvent dégager des fumées toxiques en cas de soudage.



LE SOUDAGE peut provoquer un incendie ou une explosion.

Le soudage effectué sur des conteneurs fermés tels que des réservoirs, tambours ou des conduites peut provoquer leur éclatement. Des étincelles peuvent être projetées de l'arc de soudure. La projection d'étincelles, des pièces chaudes et des équipements chauds peut provoquer des incendies et des brûlures. Le contact accidentel de l'électrode avec des objets métalliques peut provoquer des étincelles, une explosion, un surchauffement ou un incendie. Avant de commencer le soudage, vérifier et s'assurer que l'endroit ne présente pas de danger.

- Se protéger et d'autres personnes de la projection d'étincelles et de métal chaud.
- Ne pas souder dans un endroit là où des étincelles peuvent tomber sur des substances inflammables.
- Déplacer toutes les substances inflammables à une distance de 10,7 m de l'arc de soudage. En cas d'impossibilité les recouvrir soigneusement avec des protections homologués.
- Des étincelles et des matériaux chauds du soudage peuvent facilement passer dans d'autres zones en traversant de petites fissures et des ouvertures.
- Surveiller tout déclenchement d'incendie et tenir un extincteur à proximité.
- Le soudage effectué sur un plafond, plancher, paroi ou séparation peut déclencher un incendie de l'autre côté.
- Ne pas effectuer le soudage sur des conteneurs fermés tels que des réservoirs, tambours, ou conduites, à moins qu'ils n'aient été préparés correctement conformément à AWS F4.1 (voir les normes de sécurité).
- Brancher le câble sur la pièce le plus près possible de la zone de soudage pour éviter le transport du courant sur une longue distance par des chemins inconnus éventuels en provoquant des risques d'électrocution et d'incendie.
- Ne pas utiliser le poste de soudage pour dégeler des conduites gelées.
- En cas de non utilisation, enlever la bague d'électrode du porte-électrode ou couper le fil à la pointe de contact.
- Porter des vêtements de protection dépourvus d'huile tels que des gants en cuir, une chemise en matériau lourd, des pantalons sans revers, des chaussures hautes et un couvre chef.
- Avant de souder, retirer toute substance combustible de vos poches telles qu'un allumeur au butane ou des allumettes.

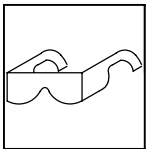

DES PARTICULES VOLANTES peuvent blesser les yeux.

- Le soudage, l'écaillage, le passage de la pièce à la brosse en fil de fer, et le meulage génèrent des étincelles et des particules métalliques volantes. Pendant la période de refroidissement des soudures, elles risquent de projeter du laitier.
 - Porter des lunettes de sécurité avec écrans latéraux ou un écran facial.



LES ACCUMULATIONS DE GAZ risquent de provoquer des blessures ou même la mort.

- Fermer l'alimentation du gaz protecteur en cas de non utilisation.
 - Veiller toujours à bien aérer les espaces confinés ou se servir d'un respirateur d'adduction d'air homologué.



DES PIÈCES CHAUDES peuvent provoquer des brûlures graves.

- Prévoir une période de refroidissement avant d'effectuer des travaux d'entretien.
- Porter des gants et des vêtements de protection pour travailler sur un moteur chaud.
 - Ne pas toucher à mains nues les parties chaudes du moteur ni les pièces récemment soudées.

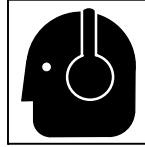

LE BRUIT peut affecter l'ouïe.

Le bruit des processus et des équipements peut affecter l'ouïe.

- Porter des protections approuvés pour les oreilles si le niveau sonore est trop élevé.

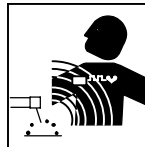

LES CHAMPS MAGNÉTIQUES peuvent affecter les stimulateurs cardiaques.

- Porteurs de stimulateur cardiaque, restez à distance.
- Les porteurs d'un stimulateur cardiaque doivent d'abord consulter leur médecin avant de s'approcher des opérations de soudage à l'arc, de gougeage ou de soudage par points.

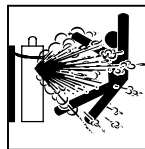

Si des BOUTEILLES sont endommagées, elles pourront exploser.

Des bouteilles de gaz protecteur contiennent du gaz sous haute pression. Si une bouteille est endommagée, elle peut exploser. Du fait que les bouteilles de gaz font normalement partie du procédé de soudage, les manipuler avec précaution.

- Protéger les bouteilles de gaz comprimé d'une chaleur excessive, des chocs mécaniques, du laitier, des flammes ouvertes, des étincelles et des arcs.
- Placer les bouteilles debout en les fixant dans un support stationnaire ou dans un porte-bouteilles pour les empêcher de tomber ou de se renverser.
- Tenir les bouteilles éloignées des circuits de soudage ou autres circuits électriques.
- Ne jamais placer une torche de soudage sur une bouteille à gaz.
- Une électrode de soudage ne doit jamais entrer en contact avec une bouteille.
- Ne jamais souder une bouteille pressurisée – risque d'explosion.
- Utiliser seulement des bouteilles de gaz protecteur, régulateurs, tuyaux et raccords convenables pour cette application spécifique; les maintenir ainsi que les éléments associés en bon état.
- Ne pas tenir la tête en face de la sortie en ouvrant la soupape de la bouteille.
- Maintenir le chapeau de protection sur la soupape, sauf en cas d'utilisation ou de branchement de la bouteille.
- Lire et suivre les instructions concernant les bouteilles de gaz comprimé, les équipements associés et les publication P-1 CGA énumérées dans les normes de sécurité.

1-3. Dangers existant en relation avec le moteur



LE CARBURANT MOTEUR peut provoquer un incendie ou une explosion.

- Arrêter le moteur avant de vérifier le niveau de carburant ou de faire le plein.
 - Ne pas faire le plein en fumant ou proche d'une source d'étincelles ou d'une flamme nue.
- Ne pas faire le plein de carburant à ras bord; prévoir de l'espace pour son expansion.
- Faire attention de ne pas renverser de carburant. Nettoyer tout carburant renversé avant de faire démarrer le moteur.
- Jeter les chiffons dans un récipient ignifuge.

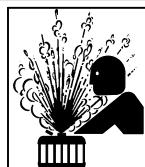

LA VAPEUR ET LE LIQUIDE DE REFROIDISSEMENT CHAUD peuvent provoquer des brûlures.

- Il est préférable de vérifier le liquide de refroidissement une fois le moteur refroidi pour éviter de se brûler.
 - Si le moteur est chaud et que le liquide doit être vérifié, opérer comme suivant :
 - Mettre des lunettes de sécurité et des gants, placer un torchon sur le bouchon du radiateur.
 - Dévisser le bouchon légèrement et laisser la vapeur s'échapper avant d'enlever le bouchon.



DES ORGANES MOBILES peuvent provoquer des blessures.

- Ne pas approcher les mains des ventilateurs, courroies et autres pièces en mouvement.
- Maintenir fermés et fixement en place les portes, panneaux, recouvrements et dispositifs de protection.
- Arrêter le moteur avant d'installer ou brancher l'appareil.
- Demander seulement à un personnel qualifié d'enlever les dispositifs de sécurité ou les recouvrements pour effectuer, s'il y a lieu, des travaux d'entretien et de dépannage.
- Pour empêcher tout démarrage accidentel pendant les travaux d'entretien, débrancher le câble négatif (-) de batterie de la borne.
- Ne pas approcher les mains, cheveux, vêtements lâches et outils des organes mobiles.
- Remettre en place les panneaux ou les dispositifs de protection et fermer les portes à la fin des travaux d'entretien et avant de faire démarrer le moteur.
- Avant d'intervenir, déposer les bougies ou injecteurs pour éviter la mise en route accidentelle du moteur.
- Bloquer le volant moteur pour éviter sa rotation lors d'une intervention sur le générateur.

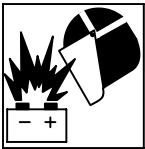

L'EXPLOSION DE LA BATTERIE peut RENDRE AVEUGLE.

- Toujours porter une protection faciale, des gants en caoutchouc et vêtements de protection lors d'une intervention sur la batterie.
- Arrêter le moteur avant de débrancher ou de brancher les câbles de batterie.
- Éviter de provoquer des étincelles avec les outils en travaillant sur la batterie.
- Ne pas utiliser le poste de soudage pour charger les batteries ou des véhicules de démarrage rapide.
- Observer la polarité correcte (+ et -) sur les batteries.
- Débrancher le câble négatif (-) en premier lieu. Le rebrancher en dernier lieu.

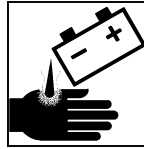

L'ACIDE DE LA BATTERIE peut provoquer des brûlures dans les YEUX et sur la PEAU.

- Ne pas renverser la batterie.
- Remplacer une batterie endommagée.
- Rincer immédiatement les yeux et la peau à l'eau.

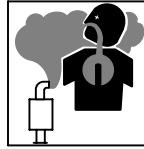

LES GAZ D'ÉCHAPPEMENT DU MOTEUR peuvent provoquer des accidents mortels.

- Utiliser l'équipement à l'extérieur dans des zones ouvertes et bien ventilées.
- En cas d'utilisation dans un endroit fermé évacuer les gaz d'échappement du moteur vers l'extérieur à distance des entrées d'air dans les bâtiments.



LA CHALEUR DU MOTEUR peut provoquer un incendie.

- Ne pas placer l'appareil sur, au-dessus ou à proximité de surfaces inflammables.
- Tenir à distance les produits inflammables de l'échappement.



LES ÉTINCELLES À L'ÉCHAPPEMENT peuvent provoquer un incendie.

- Empêcher les étincelles d'échappement du moteur de provoquer un incendie.
- Utiliser uniquement un pare-étincelles approuvé – voir codes en vigueur.

1-4. Dangers supplémentaires en relation avec l'installation, le fonctionnement et la maintenance



LA CHUTE DE L'APPAREIL peut blesser.

- Utiliser l'anneau de levage uniquement pour soulever l'appareil lui-même ; sans chariot, de bouteilles de gaz, remorque, ou autres accessoires.
- Utiliser un équipement de levage de capacité suffisante pour lever l'appareil.
- En utilisant des fourches de levage pour déplacer l'unité, s'assurer que les fourches sont suffisamment longues pour dépasser du côté opposé de l'appareil.

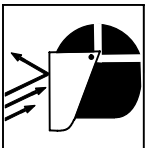

LES ÉTINCELLES VOLANTES risquent de provoquer des blessures.

- Porter un écran facial pour protéger le visage et les yeux.
- Affuturer l'électrode au tungstène uniquement à la meuleuse dotée de protecteurs. Cette manoeuvre est à exécuter dans un endroit sûr lorsque l'on porte l'équipement homologué de protection du visage, des mains et du corps.
- Les étincelles risquent de causer un incendie – éloigner toute substance inflammable.

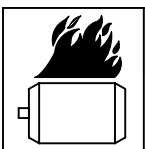

LE SURCHAUFFEMENT peut endommager le moteur électrique.

- Arrêter ou déconnecter l'équipement avant de démarrer ou d'arrêter le moteur.
- Ne pas laisser tourner le moteur trop lentement sous risque d'endommager le moteur électrique à cause d'une tension et d'une fréquence trop faibles.
- Ne pas brancher de moteur de 50 ou de 60 Hz à la prise de 100 Hz, s'il y a lieu.

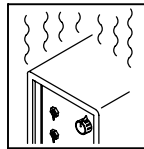

L'EMPLOI EXCESSIF peut SURCHAUFFER L'ÉQUIPEMENT.

- Laisser l'équipement refroidir ; respecter le facteur de marche nominal.
- Réduire le courant ou le facteur de marche avant de poursuivre le soudage.
- Ne pas obstruer les passages d'air du poste.

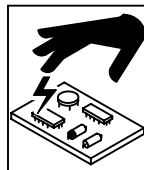

LES CHARGES ÉLECTROSTATIQUES peuvent endommager les circuits imprimés.

- Établir la connexion avec la barrette de terre avant de manipuler des cartes ou des pièces.
- Utiliser des pochettes et des boîtes antistatiques pour stocker, déplacer ou expédier des cartes de circuits imprimés.

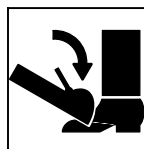

UNE REMORQUE QUI BASCULE peut entraîner des blessures.

- Utiliser les supports de la remorque ou des blocs pour soutenir le poids.
- Installer convenablement le poste sur la remorque comme indiqué dans le manuel s'y rapportant.

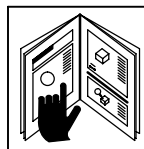

LIRE LES INSTRUCTIONS.

- Utiliser uniquement des pièces de rechange MILLER.
- Effectuer la maintenance et la mise en service d'après le manuel et celui du moteur.

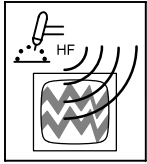

LE RAYONNEMENT HAUTE FRÉQUENCE (H.F.) risque de provoquer des interférences.

- Le rayonnement haute fréquence (H.F.) peut provoquer des interférences avec les équipements de radio-navigation et de communication, les services de sécurité et les ordinateurs.
- Demander seulement à des personnes qualifiées familiarisées avec des équipements électroniques de faire fonctionner l'installation.
- L'utilisateur est tenu de faire corriger rapidement par un électricien qualifié les interférences résultant de l'installation.
- Si le FCC signale des interférences, arrêter immédiatement l'appareil.
- Effectuer régulièrement le contrôle et l'entretien de l'installation.
- Maintenir soigneusement fermés les portes et les panneaux des sources de haute fréquence, maintenir les éclateurs à une distance correcte et utiliser une terre et un blindage pour réduire les interférences éventuelles.

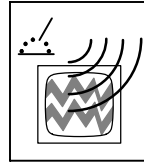

LE SOUDAGE À L'ARC risque de provoquer des interférences.

- L'énergie électromagnétique risque de provoquer des interférences pour l'équipement électronique sensible tel que les ordinateurs et l'équipement commandé par ordinateur tel que les robots.
- Veiller à ce que tout l'équipement de la zone de soudage soit compatible électromagnétiquement.
- Pour réduire la possibilité d'interférence, maintenir les câbles de soudage aussi courts que possible, les grouper, et les poser aussi bas que possible (ex. par terre).
- Veiller à souder à une distance de 100 mètres de tout équipement électronique sensible.
- Veiller à ce que ce poste de soudage soit posé et mis à la terre conformément à ce mode d'emploi.
- En cas d'interférences après avoir pris les mesures précédentes, il incombe à l'utilisateur de prendre des mesures supplémentaires telles que le déplacement du poste, l'utilisation de câbles blindés, l'utilisation de filtres de ligne ou la pose de protecteurs dans la zone de travail.

1-5. Principales normes de sécurité

Safety in Welding and Cutting, norme ANSI Z49.1, de l'American Welding Society, 550 N.W. Lejeune Rd, Miami FL 33126

Safety and Health Standards, OSHA 29 CFR 1910, du Superintendent of Documents, U.S. Government Printing Office, Washington, D.C. 20402.

Recommended Safe Practice for the Preparation for Welding and Cutting of Containers That Have Held Hazardous Substances, norme AWS F4.1, de l'American Welding Society, 550 N.W. Lejeune Rd, Miami FL 33126

National Electrical Code, NFPA Standard 70, de la National Fire Protection Association, Batterymarch Park, Quincy, MA 02269.

Safe Handling of Compressed Gases in Cylinders, CGA Pamphlet P-1, de la Compressed Gas Association, 1235 Jefferson Davis Highway, Suite 501, Arlington, VA 22202.

Règles de sécurité en soudage, coupage et procédés connexes, norme CSA W117.2, de l'Association canadienne de normalisation, vente de normes, 178 Rexdale Boulevard, Rexdale (Ontario) Canada M9W 1R3.

Safe Practices For Occupation And Educational Eye And Face Protection, norme ANSI Z87.1, de l'American National Standards Institute, 1430 Broadway, New York, NY 10018.

Cutting and Welding Processes, norme NFPA 51B, de la National Fire Protection Association, Batterymarch Park, Quincy, MA 02269.

1-6. Information sur les champs électromagnétiques

Données sur le soudage électrique et sur les effets, pour l'organisme, des champs magnétiques basse fréquence

Le courant de soudage, pendant son passage dans les câbles de soudage, causera des champs électromagnétiques. Il y a eu et il y a encore un certain souci à propos de tels champs. Cependant, après avoir examiné plus de 500 études qui ont été faites pendant une période de recherche de 17 ans, un comité spécial ruban bleu du National Research Council a conclu: "L'accumulation de preuves, suivant le jugement du comité, n'a pas démontré que l'exposition aux champs magnétiques et champs électriques à haute fréquence représente un risque à la santé humaine". Toutefois, des études sont toujours en cours et les preuves continuent à être examinées. En attendant que les conclusions finales de la recherche soient établies, il vous serait souhaitable de réduire votre exposition aux champs électromagnétiques pendant le soudage ou le coupage.

Afin de réduire les champs électromagnétiques dans l'environnement de travail, respecter les consignes suivantes :



















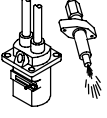
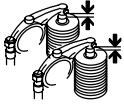













- 1 Garder les câbles ensemble en les torsadant ou en les attachant avec du ruban adhésif.
- 2 Mettre tous les câbles du côté opposé de l'opérateur.
- 3 Ne pas courber pas et ne pas entourer pas les câbles autour de votre corps.
- 4 Garder le poste de soudage et les câbles le plus loin possible de vous.
- 5 Relier la pince de masse le plus près possible de la zone de soudure.

Consignes relatives aux stimulateurs cardiaques :

Les personnes qui portent un stimulateur cardiaque doivent avant tout consulter leur docteur. Si vous êtes déclaré apte par votre docteur, il est alors recommandé de respecter les consignes ci-dessus.

SECTION 2 – DEFINITIONS

2-1. Symbols And Definitions

	Stop Engine		Start Engine		Ether Starting Aid		Engine
	Do Not Switch While Welding		Battery (Engine)		Circuit Breaker		Engine Oil
	Check Injectors/ Pump		Check Valve Clearance		Fuel		Protective Earth (Ground)
	Positive		Negative		Certified/Trained Mechanic		Welding Arc
	Amperes		Volts		Panel/Local		Remote
	On		Temperature		Output		Alternating Current
	Stick (SMAW) Welding		Constant Current (CC)		MIG (GMAW) Welding		Constant Voltage (CV)
	Time		Hours		Seconds		Single Phase
	Three Phase		Read Operator's Manual				

SECTION 3 – SPECIFICATIONS

3-1. Weld, Power, And Engine Specifications

Welding Mode	Weld Output Range	Rated Welding Output	Maximum Open-Circuit Voltage	Auxiliary Power Rating	Engine	Fuel Capacity
CC/DC	45 – 600 A	600 A, 30 Volts DC, 40% Duty Cycle	95 (88 in CC mode on units with CV)	Single-Phase, 3 kVA/kW, 25 A, 120 V AC, 60 Hz	Deutz F3L-912 Air-Cooled, Three-Cylinder, 41.5 HP Diesel Engine	23 gal (87 L)
CV/DC (Optional)	14 – 38 V	400 A, 36 Volts DC, 100% Duty Cycle	48			

3-2. Dimensions, Weights, And Operating Angles

Dimensions	
Height	47-5/8 in (1210 mm)
Width	31-1/4 in (794 mm)
Depth	60-1/2 in (1537 mm)
A	59-1/8 in (1502 mm)
B	47-1/4 in (1200 mm)
C	43-1/4 in (1099 mm)
D	32-3/4 in (832 mm)
E	24-15/16 in (633 mm)
F	10-1/2 in (267 mm)
G	6-1/2 in (165 mm)
H	2-7/8 in (73 mm)
J	29-7/8 in (759 mm)
K	11/16 in (24 mm)
L	21/32 in (17 mm) Dia. 16 Holes
Weight	
1898 lb (861 kg)	

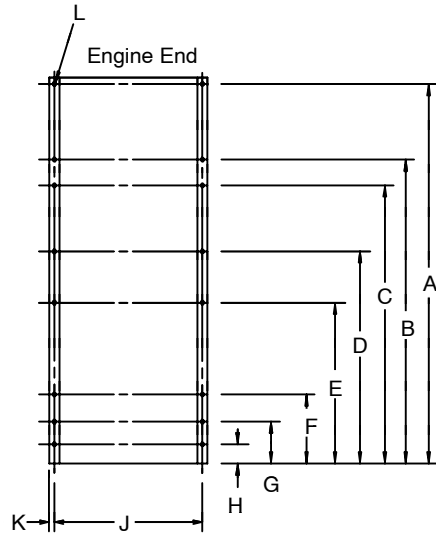

ST-158 699



- ▲ Do not exceed operating angles while running or engine damage will occur.
- ▲ Do not move or operate unit where it could tip.

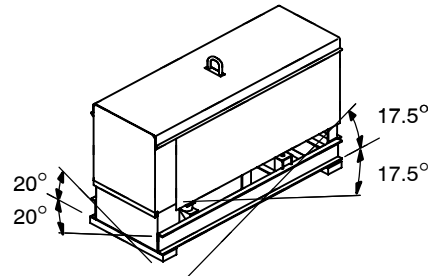

angles_1 3/96

3-3. Fuel Consumption

The curve shows typical fuel use under weld or power loads.

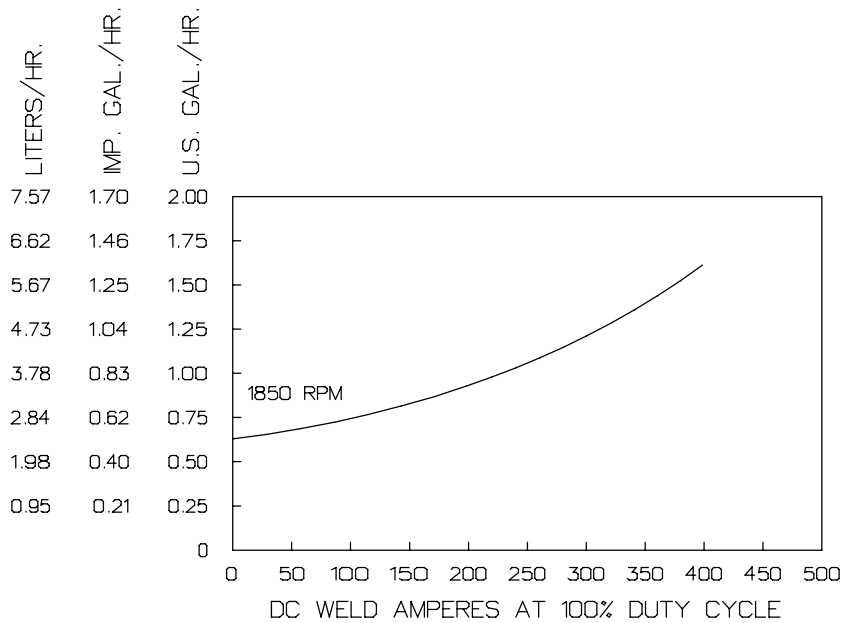

Ref. ST-047 094-C

3-4. Duty Cycle And Overheating

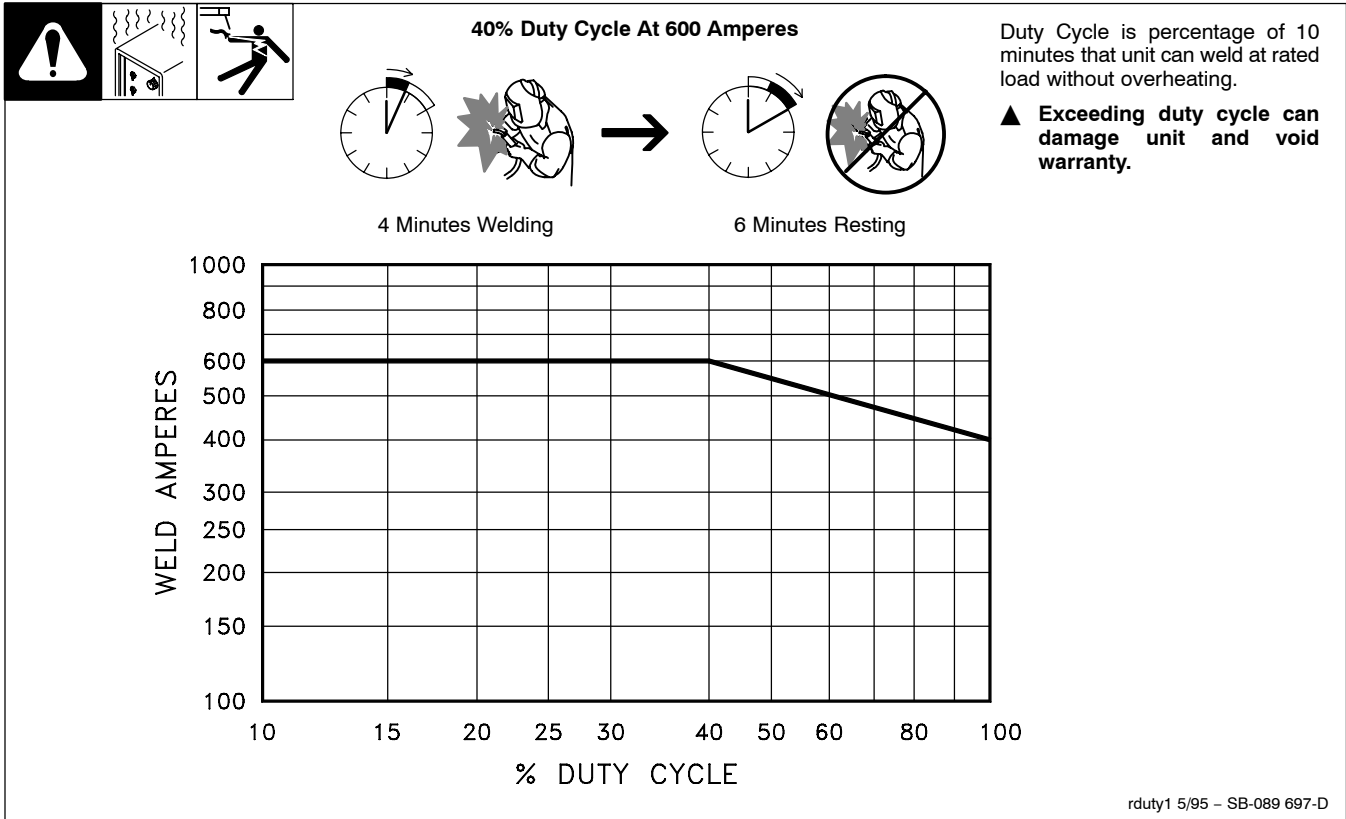

3-5. AC Auxiliary Power

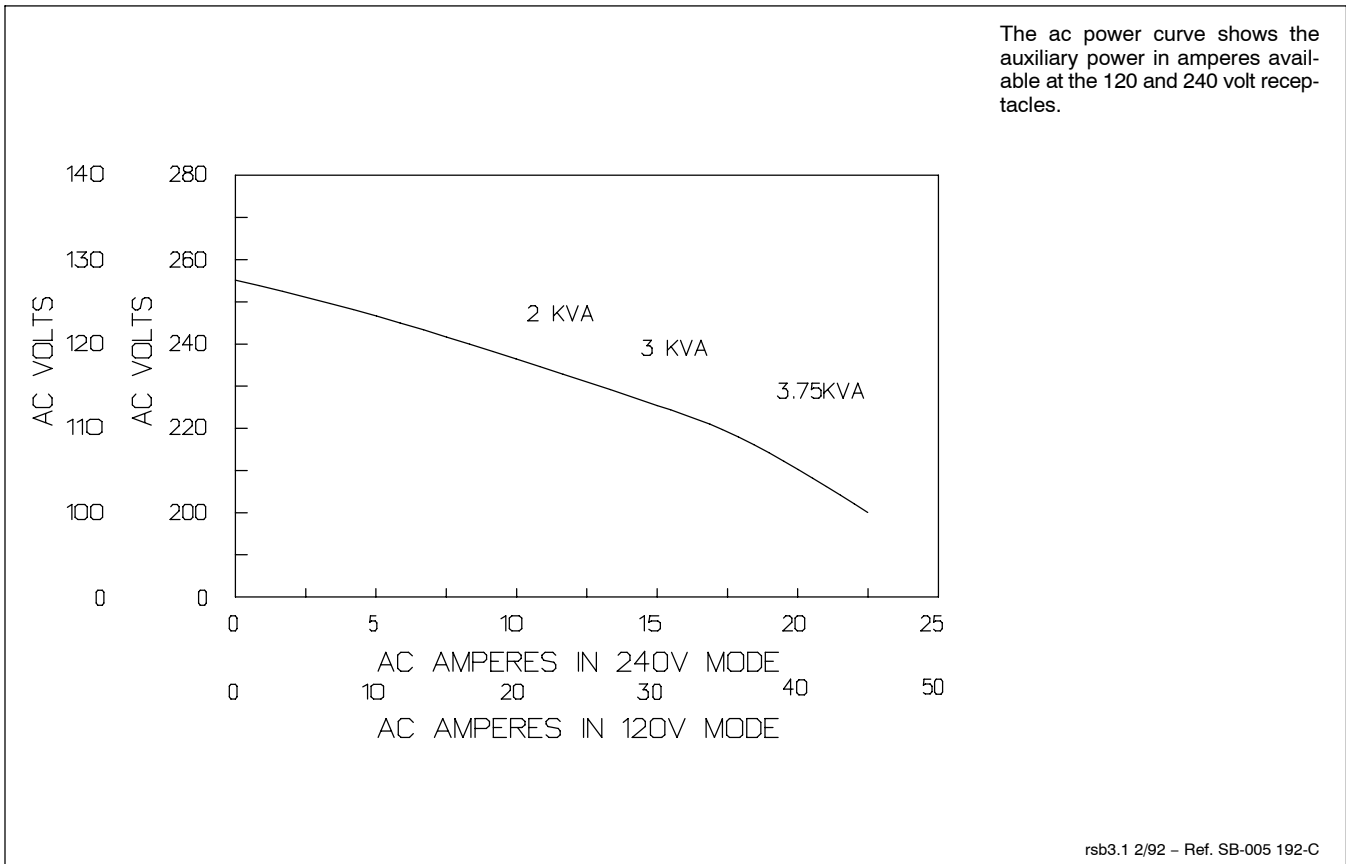

3-6. Volt-Ampere Curves

The volt-ampere curve shows the minimum and maximum voltage and amperage output capabilities of the welding generator. Curves of all other settings fall between the curves shown.

A. CC/DC (Standard)

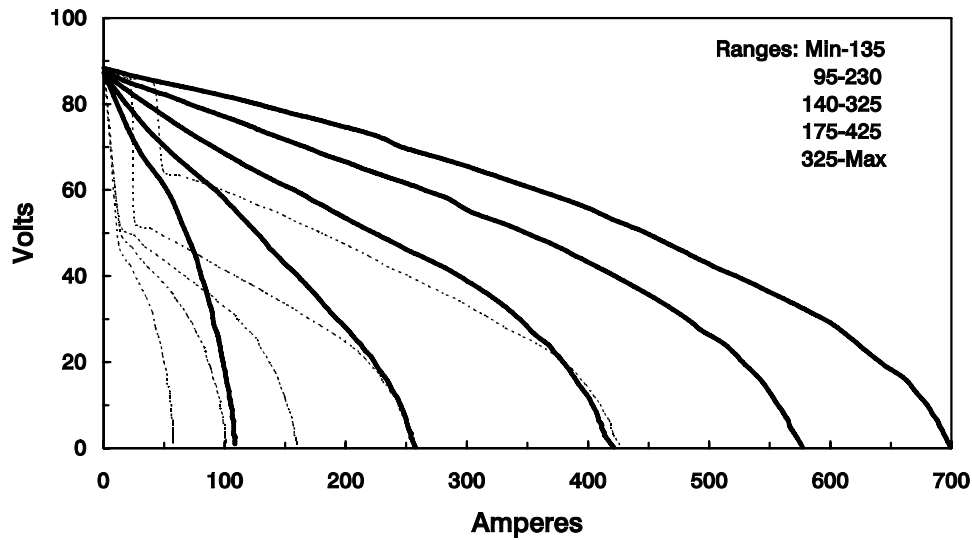

B. CV/DC (Models With CV Option)

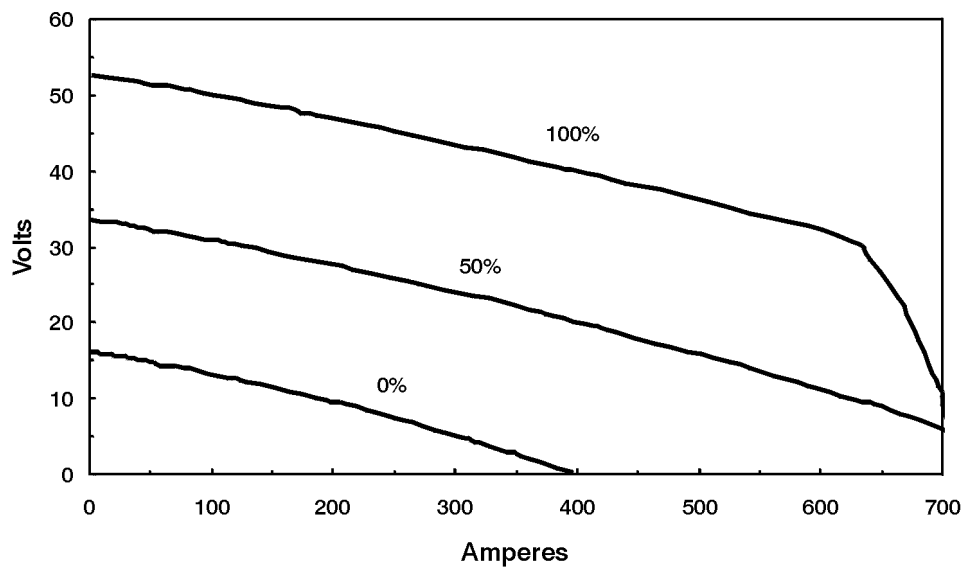

ST-183 880-A / ST-186 173-A

3-7. Optional AC Power Plant Curves

The ac power curves show the auxiliary power in amperes available at the single-phase 120/240 volt or three-phase 240 volt terminals.

A. 7.5 KVA/KW Single-Phase Auxiliary Power Plant (No Weld Load)

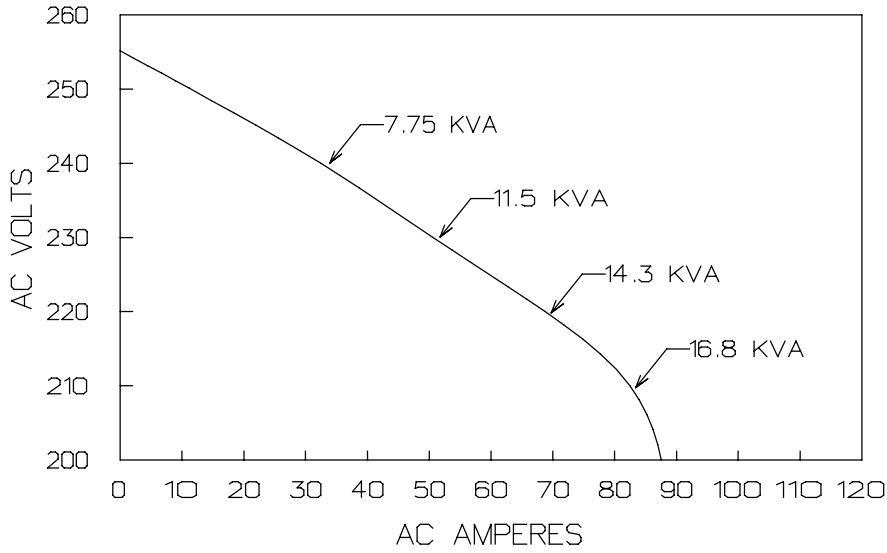

B. 10 KVA/KW Three-Phase Auxiliary Power Plant (No Weld Load)

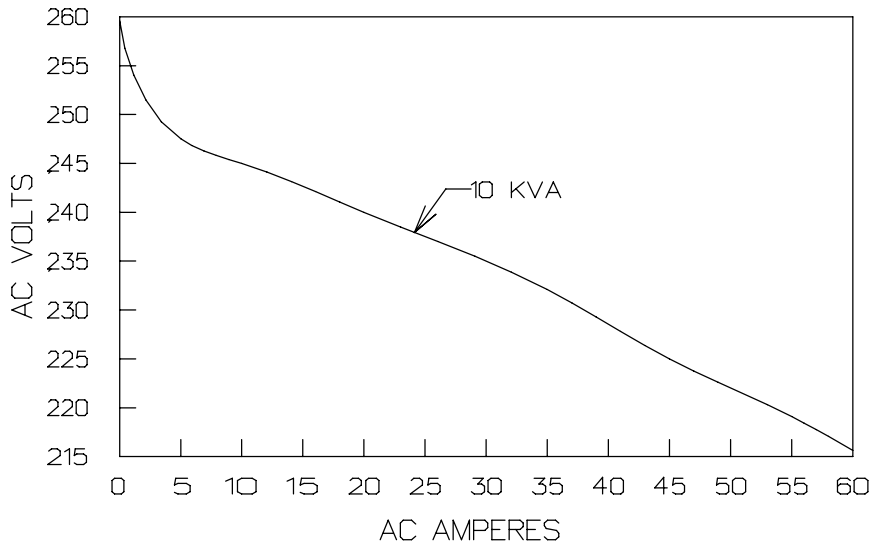

SECTION 4 – INSTALLATION

4-1. Installing Welding Generator

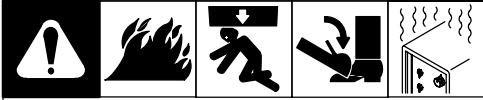

Movement

▲ Do Not Lift Unit From End

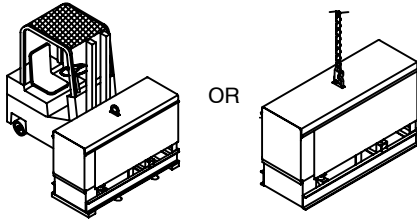

Airflow Clearance

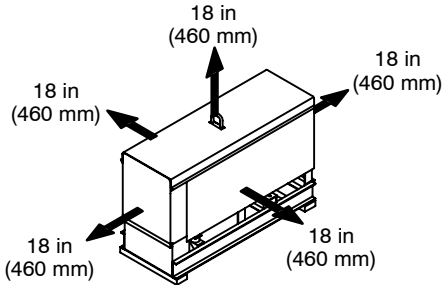

Location

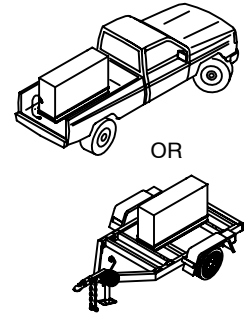

Grounding

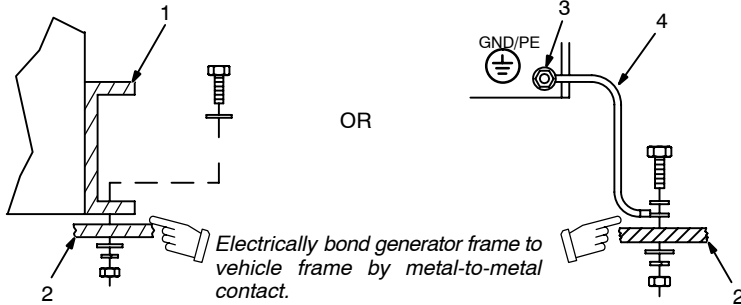

- 1 Generator Base
- 2 Metal Vehicle Frame
- 3 Equipment Grounding Terminal
- 4 Grounding Cable

Use #10 AWG or larger insulated copper wire.

▲ If unit does not have GFCI receptacles, use GFCI-protected extension cord.

install1 3/96 – Ref. ST-800 652 / Ref. ST-800 477-A / ST-158 936-A / S-0854

4-2. Installing Exhaust Pipe

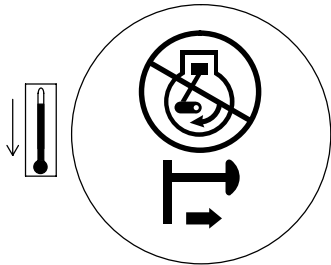

Tools Needed:

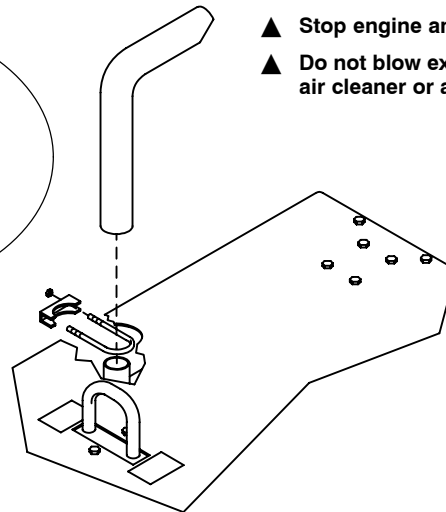
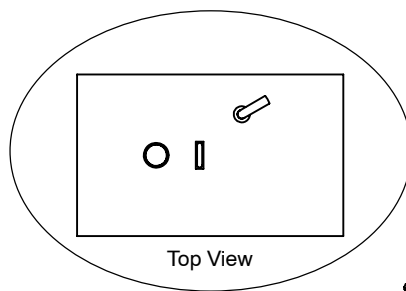
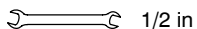

- ▲ Stop engine and let cool.
- ▲ Do not blow exhaust toward air cleaner or air intake.

exh_pipe2 4/96 – ST-154 089-A / ST-154 611 / ST-180 933-B

4-3. Activating The Dry Charge Battery

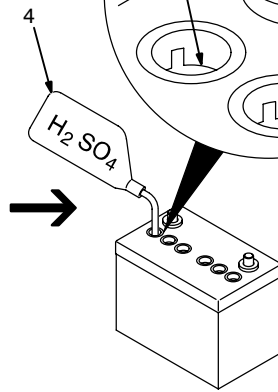
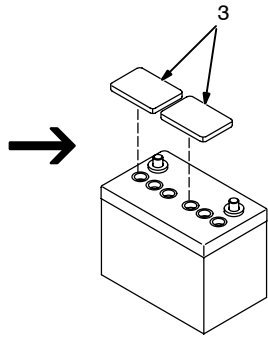
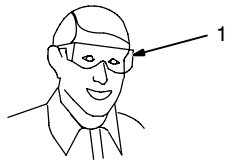
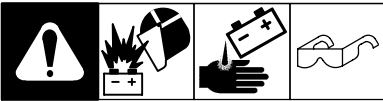

Remove battery from unit.

- 1 Eye Protection – Safety Glasses Or Face Shield
- 2 Rubber Gloves
- 3 Vent Caps
- 4 Sulfuric Acid Electrolyte (1.265 Specific Gravity)
- 5 Well

Fill each cell with electrolyte to **bottom** of well (maximum).

▲ **Do not overfill battery cells.**

Wait ten minutes and check electrolyte level. If necessary, add electrolyte to raise to proper level. Reinstall vent caps.

6 Battery Charger

▲ **Read and follow all instructions supplied with battery charger.**

Charge battery for 12 minutes at 30 amperes or 30 minutes at 5 amperes. Disconnect charging cables and install battery.

☞ *When electrolyte is low, add only distilled water to cells to maintain proper level.*

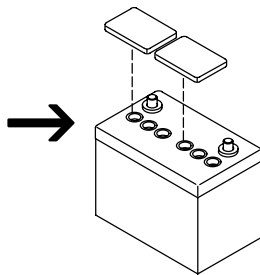
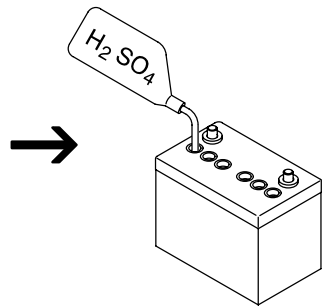
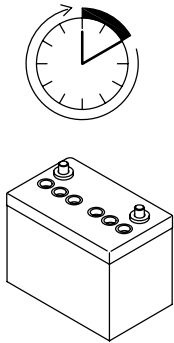

5 A For 30 Minutes

OR



30 A For 12 Minutes

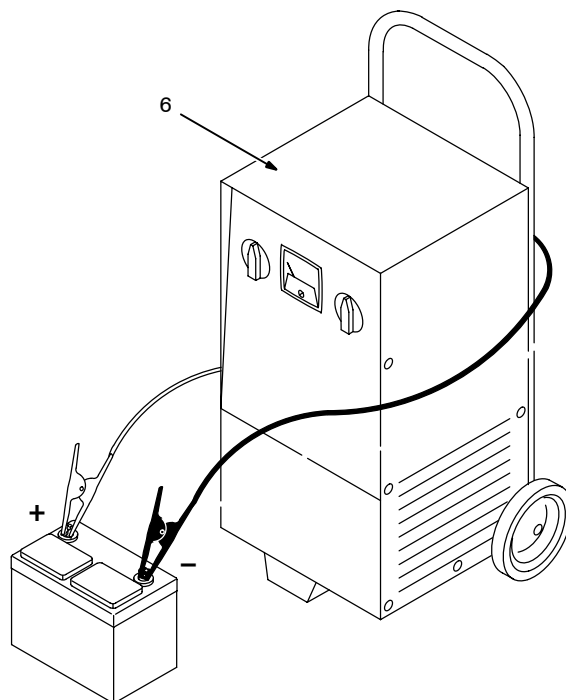

Tools Needed:



drybatt1 2/96 – S-0886

4-4. Connecting The Battery

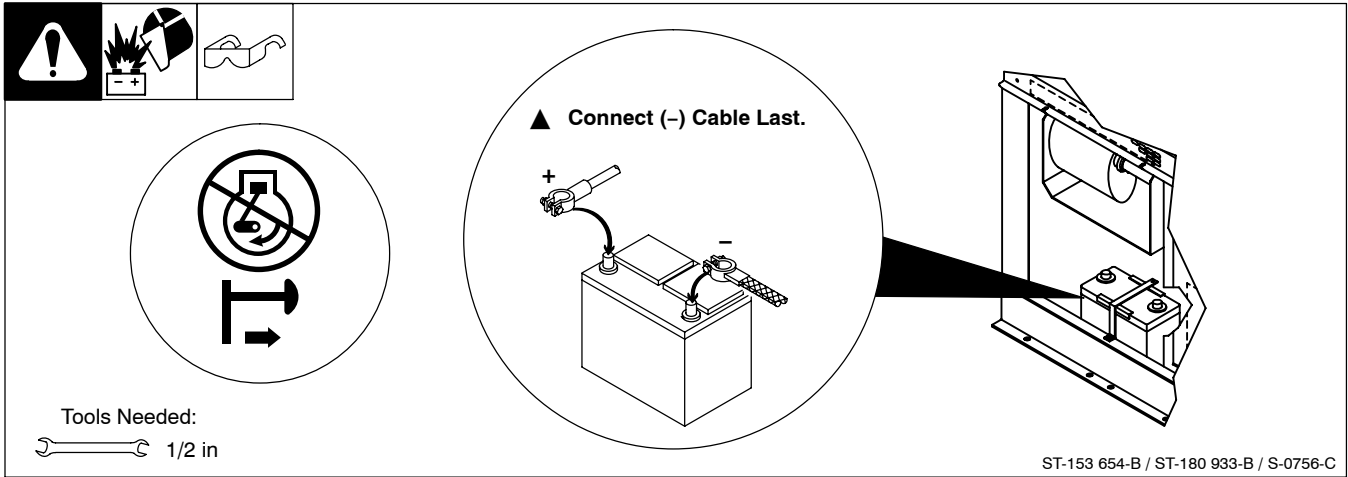

▲ **Connect (-) Cable Last.**

Tools Needed:
 1/2 in

ST-153 654-B / ST-180 933-B / S-0756-C

4-5. Engine Prestart Checks

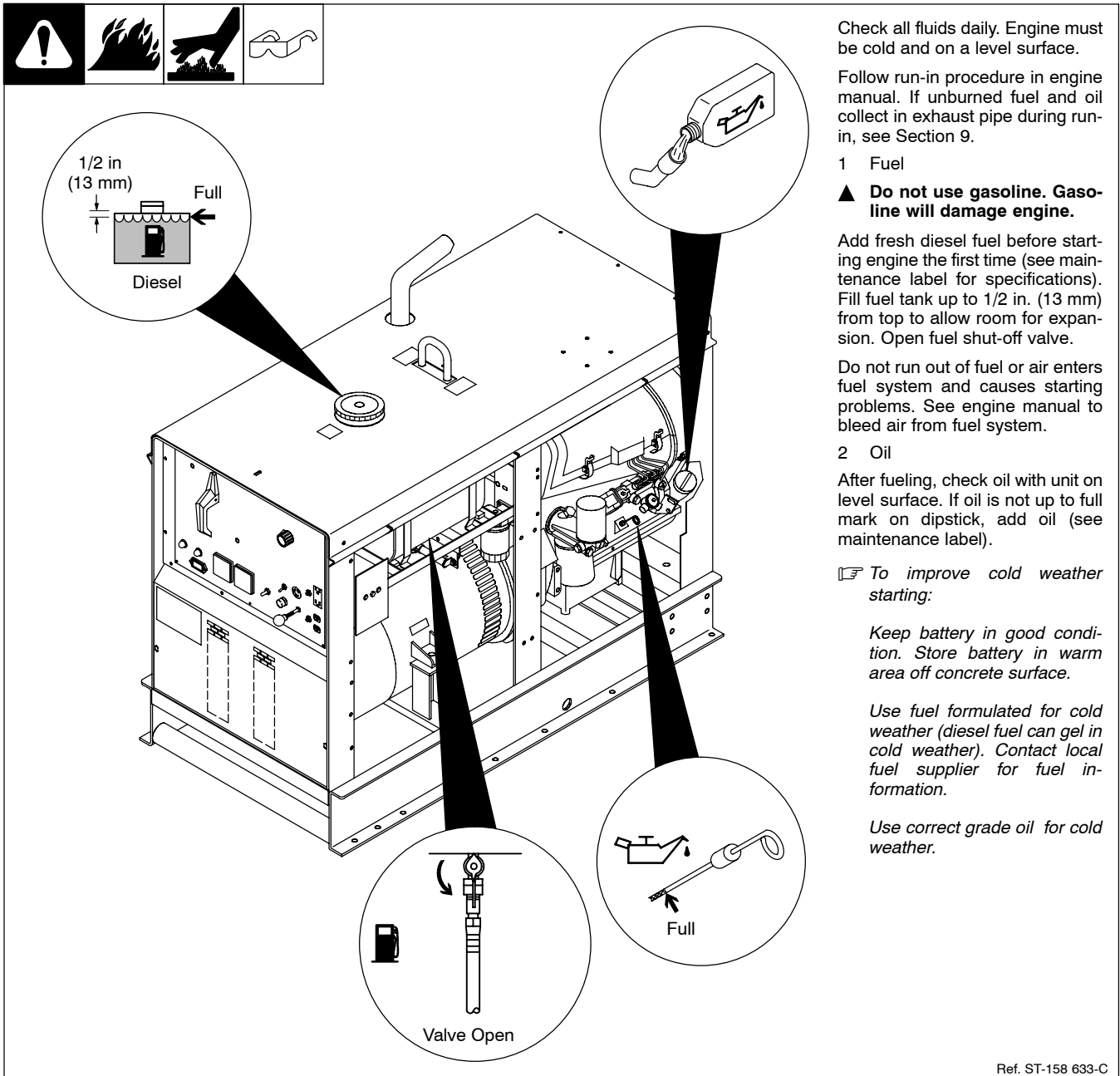

1/2 in (13 mm) Full
 Diesel

1 Fuel

▲ **Do not use gasoline. Gasoline will damage engine.**

Add fresh diesel fuel before starting engine the first time (see maintenance label for specifications). Fill fuel tank up to 1/2 in. (13 mm) from top to allow room for expansion. Open fuel shut-off valve.

Do not run out of fuel or air enters fuel system and causes starting problems. See engine manual to bleed air from fuel system.

2 Oil

After fueling, check oil with unit on level surface. If oil is not up to full mark on dipstick, add oil (see maintenance label).

☞ *To improve cold weather starting:*

Keep battery in good condition. Store battery in warm area off concrete surface.

Use fuel formulated for cold weather (diesel fuel can gel in cold weather). Contact local fuel supplier for fuel information.

Use correct grade oil for cold weather.

Valve Open

Full

Ref. ST-158 633-C

4-6. Connecting To Weld Output Terminals

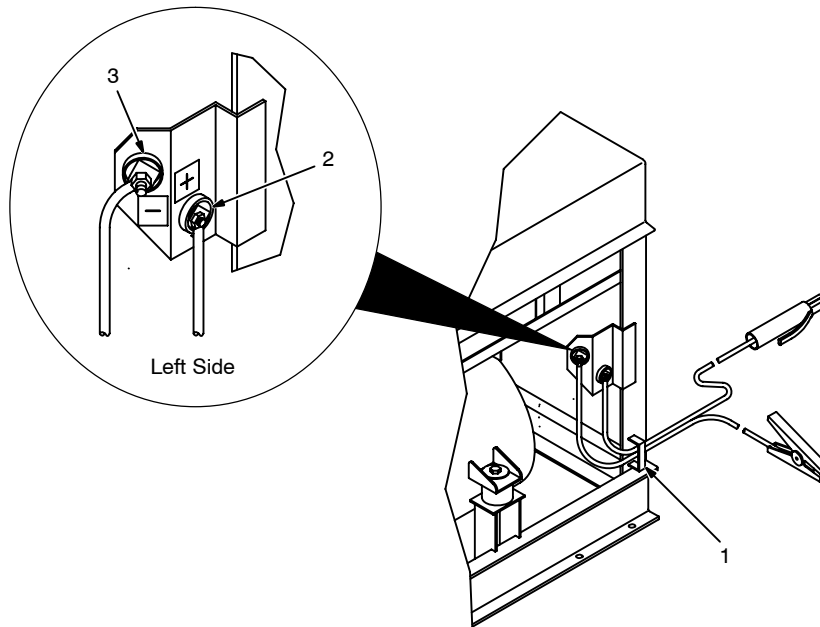

Open left side door.

1 Bracket

Route cables through bracket.

2 Positive (+) Weld Output Terminal

3 Negative (-) Weld Output Terminal

For Stick welding Direct Current Electrode Positive (DCEP), connect work cable to - terminal and electrode holder cable to + terminal.

For Direct Current Electrode Negative (DCEN), reverse cable connections.

If equipped with optional polarity switch, connect electrode holder cable to Electrode (-) terminal and work cable to Work (+) terminal.

For MIG and FCAW welding with CV option, connect work cable to (-) terminal and wire feeder cable to (+) terminal

Close door.

Tools Needed:

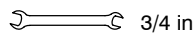

3/4 in

ST-158 700

4-7. Selecting Weld Cable Sizes

Welding Amperes	Total Cable (Copper) Length In Weld Circuit Not Exceeding							
	100 ft (30 m) Or Less		150 ft (45 m)	200 ft (60 m)	250 ft (70 m)	300 ft (90 m)	350 ft (105 m)	400 ft (120 m)
	10 – 60% Duty Cycle	60 – 100% Duty Cycle	10 – 100% Duty Cycle					
100	4	4	4	3	2	1	1/0	1/0
150	3	3	2	1	1/0	2/0	3/0	3/0
200	3	2	1	1/0	2/0	3/0	4/0	4/0
250	2	1	1/0	2/0	3/0	4/0	2-2/0	2-2/0
300	1	1/0	2/0	3/0	4/0	2-2/0	2-3/0	2-3/0
350	1/0	2/0	3/0	4/0	2-2/0	2-3/0	2-3/0	2-4/0
400	1/0	2/0	3/0	4/0	2-2/0	2-3/0	2-4/0	2-4/0
500	2/0	3/0	4/0	2-2/0	2-3/0	2-4/0	3-3/0	3-3/0
600	3/0	4/0	2-2/0	2-3/0	2-4/0	3-3/0	3-4/0	3-4/0
700	4/0	2-2/0	2-3/0	2-4/0	3-3/0	3-4/0	3-4/0	4-4/0

*Weld cable size (AWG) is based on either a 4 volts or less drop or a current density of at least 300 circular mils per ampere. Contact your distributor for the mm² equivalent weld cable sizes.

S-0007-E

4-8. Installing Ether Cylinder (Optional Ether Starting Aid)

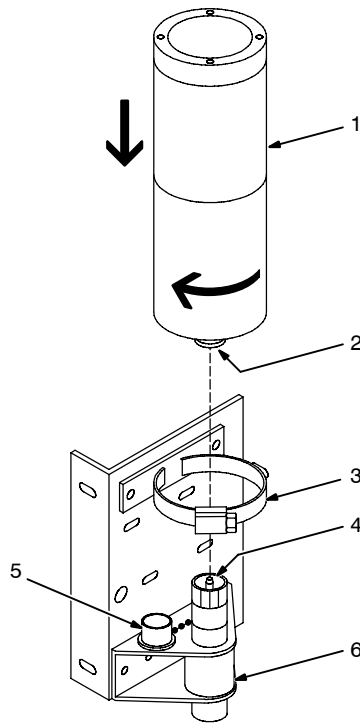
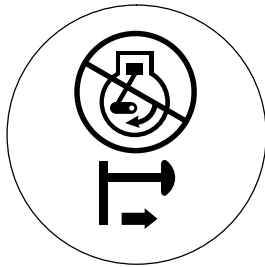

- ▲ Stop engine.
- ▲ Improper handling or exposure to ether can harm your health. Follow manufacturer's safety instructions on cylinder.
- ▲ Do not use Ether Starting Aid while engine is running.

Open side door(s).

- 1 Ether Cylinder
- 2 Nozzle

Remove cover and clean cylinder nozzle.

- 3 Clamp
- 4 Fitting
- 5 Cap
- 6 Valve

Remove cap and clean fitting. Install cylinder on fitting. Tighten clamp.

☞ After installing cylinder, wait at least 10 minutes before using to let ether particles settle and prevent atomizer plugging.

Put cap on fitting when cylinder is removed.

ether1 7/96 - ST-153 382-A / ST-180 933-B

4-9. Remote A/V Control Receptacle RC3

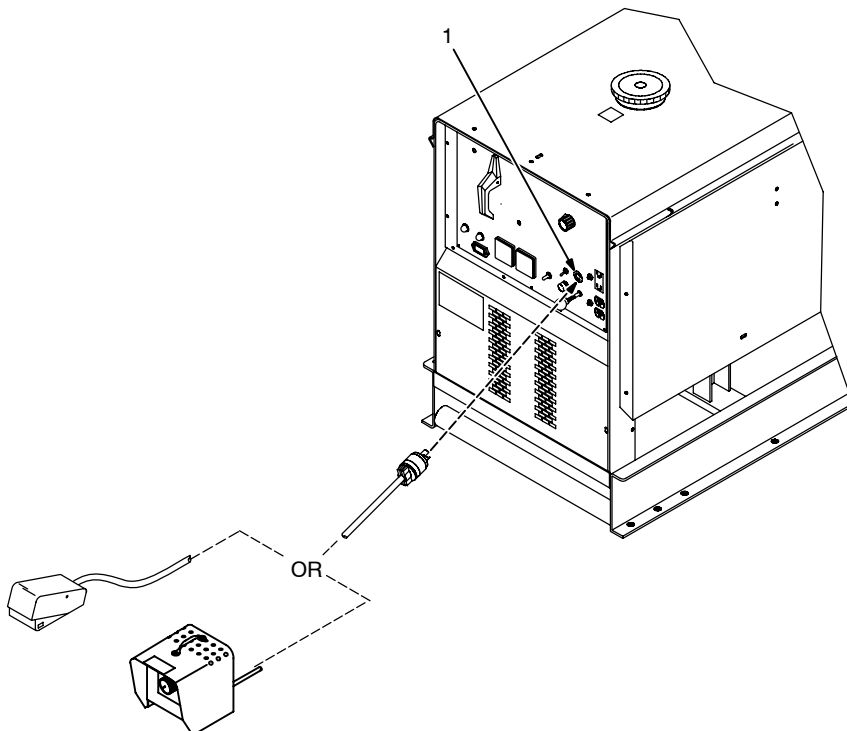

- 1 Remote A/V Receptacle RC3
- Connect optional remote control to RC3 (see Section 5-1).

Ref. ST-154 862-A / ST-048 720-K

4-10. Remote 14 Receptacle RC3 Information (Optional)

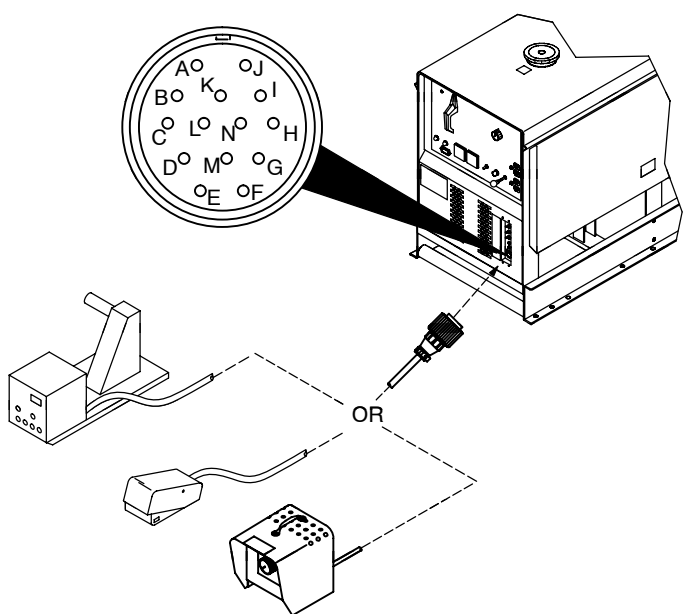

Ref. ST-800 862-B

REMOTE 14	Socket*	Socket Information
	A	24 volts ac. Protected by circuit breaker CB4.
	B	Contact closure to A completes 24 volts ac contactor control circuit.
	I	115 volts ac. Protected by circuit breaker CB3.
	J	Contact closure to I completes 115 volts ac contactor control circuit.
A/V	G	Circuit common for 24 and 115 volts ac circuits.
	C	0 to +10 volts dc output to remote control from min to max of Amperage/Voltage control R1.
	D	Remote control circuit common.
	E	0 to +10 volts dc input command signal from remote control.
	K	Chassis common.

*The remaining sockets are not used.

4-11. Terminal Strip 2T Connections (Optional)

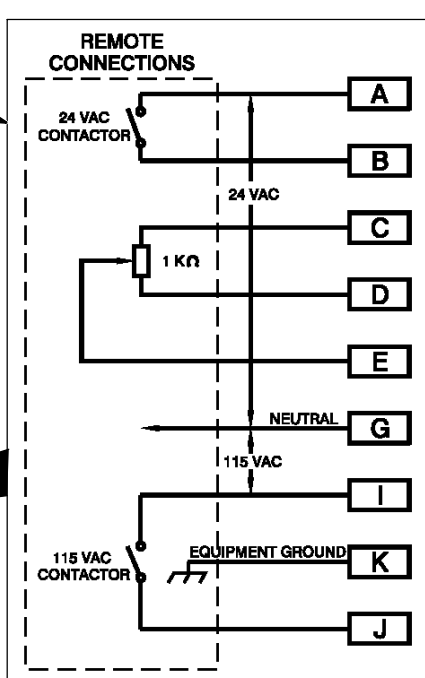
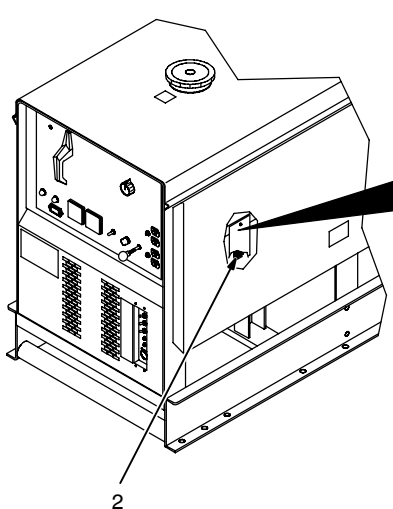
▲ Stop engine.
If remote control plug does not fit in receptacle RC3, wire cord directly to terminal strip 2T.

▲ Do not connect to Remote 14 receptacle RC3 and terminal strip 2T at the same time. Use only one remote control method.

Open right side door.

- Cover
- Terminal Strip 2T

Connect leads to 2T using terminal information shown in Section 4-10.

Reinstall cover. Close door.

Tools Needed:

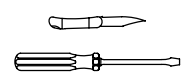

Ref. ST-800 862-B / Ref. ST-185 316

SECTION 5 – OPERATING THE WELDING GENERATOR

5-1. Standard Controls (See Section 5-2)

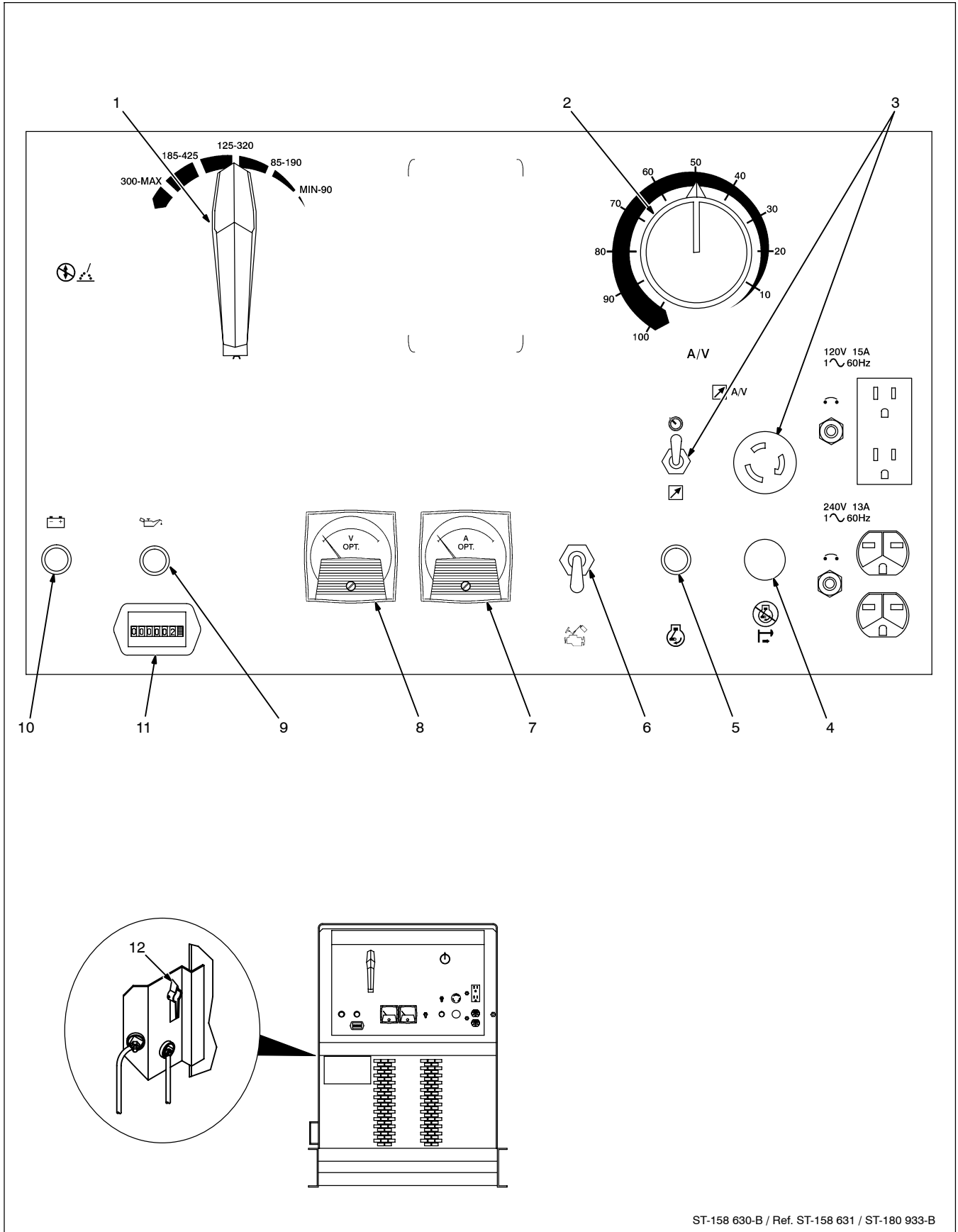

5-2. Description Of Standard Controls (See Section 5-1)

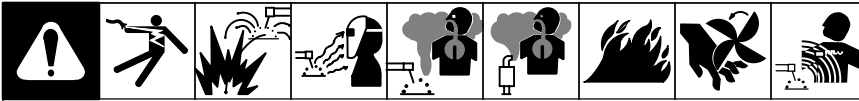

This unit has a max OCV control circuit that resets the Amperage/Voltage Control to maximum when the arc breaks. When an arc is struck, weld output control returns to the front panel or remote control setting. The Amperage/voltage Control adjusts amperage only when welding and does not adjust open-circuit voltage.

1 Ampere Range Switch

Use switch to select one of five ampere ranges.

For most welding applications, use lowest ampere range possible to help prevent arc outages.

▲ **Do not switch under load.**

2 Amperage/Voltage Control

Control adjusts amperage within range selected by Ampere Range switch. Weld output

would be 223 A DC with controls set as shown (50% of 125 to 320 A).

3 Remote A/V Control Receptacle And Switch

Connect optional remote control to RC3 (See Section 4-9). Use switch to select front panel or remote amperage control (see example below).

4 Manual Stop Control

5 Engine Start Button

6 Ether Starting Aid Switch (Optional)

Push switch up and release while cranking engine to release ether.

▲ **Do not use Ether if engine is running.**

To Start: Press button and use Ether switch (if necessary). Release button when engine starts.

Do not crank engine while engine is turning.

To Stop: Pull control out and hold. Release control when engine stops.

7 DC Ammeter (Optional)

8 DC Voltmeter (Optional)

9 Oil Pressure Warning Light

Light goes off if oil pressure is too low.

▲ **If light goes off, stop engine and check oil level.**

10 Battery Charging Warning Light

Light goes on when battery is not charging.

▲ **If light goes on, stop engine and check engine belt.**

11 Engine Hour Meter

12 Polarity Switch (Optional)

Example: Combination Remote Amperage Control

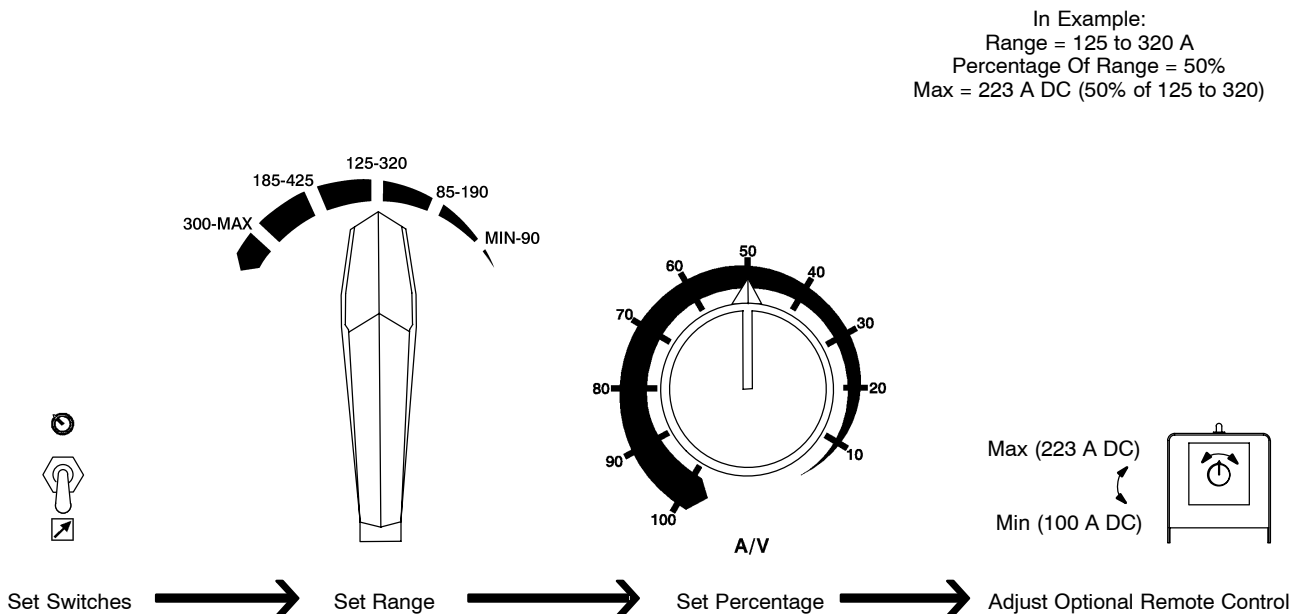

5-3. Controls For Models With CV Option (See Section 5-4)

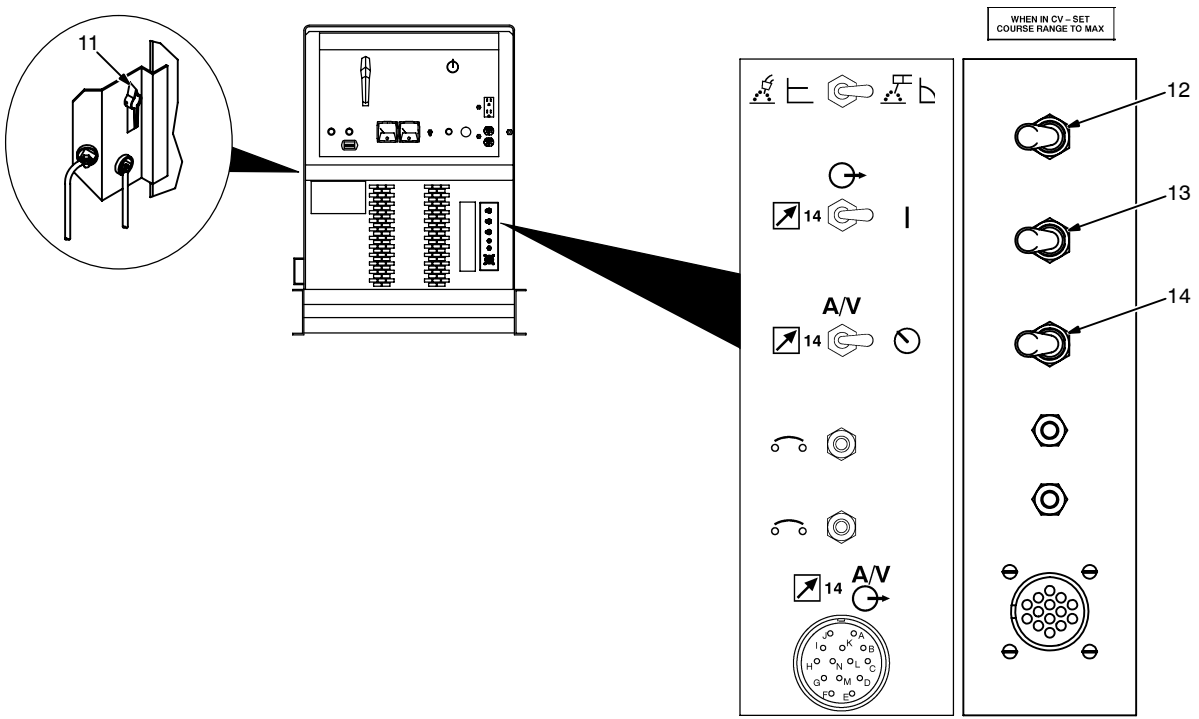
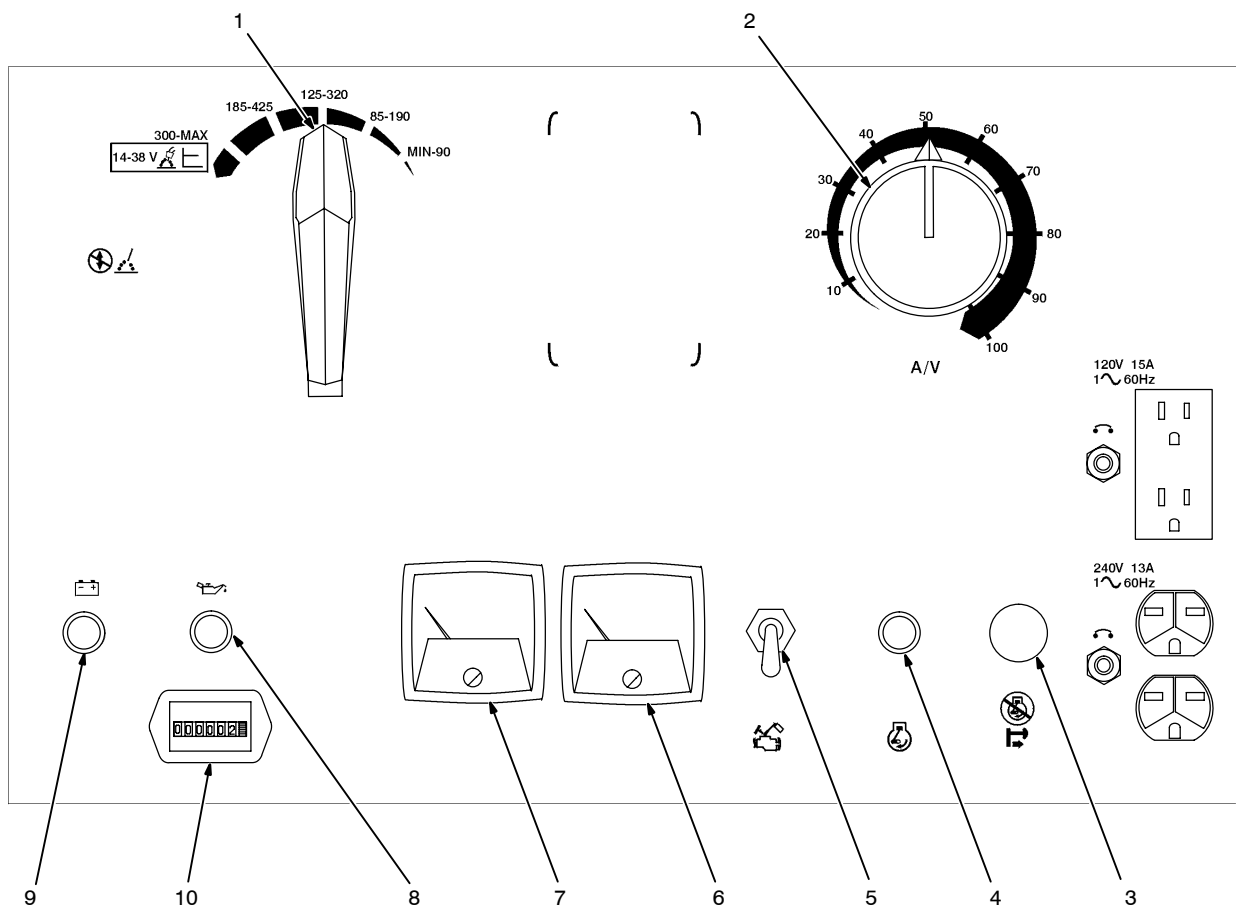

5-4. Description Of Controls For Models With CV Option (See Section 5-3)

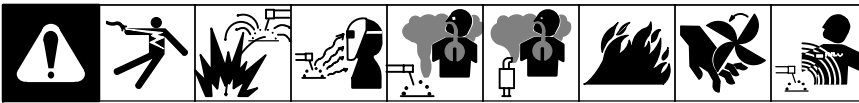

☞ This unit has a max OCV control circuit that resets Amperage/Voltage Control R1 to maximum when the arc breaks. When an arc is struck, weld output control returns to the R1 front panel or combination front panel/remote control setting. The Amperage/Voltage control adjusts amperage only when constant current (CC) welding and does not adjust open-circuit voltage. The max OCV control circuit does not function when constant voltage (CV) welding.

1 Ampere Range Switch

▲ Do not switch under load.

Use switch to select one of five ampere ranges. Use the lower four ranges for CC welding. Use the highest range for CV/DC welding.

For most welding applications, use lowest amperage range possible to help prevent arc outages.

2 Amperage/Voltage Control

With CC/CV switch in CC position, use control to adjust amperage within range selected by Ampere Ranges switch. With switch in CV position, use control to adjust voltage.

Weld output would be 223 A DC with amperage controls set as shown (50% of 125 to 320 A).

3 Manual Stop Control

4 Engine Start Button

5 Ether Starting Aid Switch (Optional)

Push switch up and release while cranking engine to release ether.

▲ Do not use Ether if engine is running.

To Start: Press button and use Ether switch (if necessary). Release button when engine starts.

Do not crank engine while engine is turning.

To Stop: Pull control out and hold. Release control when engine stops.

6 DC Ammeter (Optional)

7 DC Voltmeter (Optional)

8 Oil Pressure Warning Light

Light goes off if oil pressure is too low.

▲ If light goes off, stop engine and check oil level.

9 Battery Charging Warning Light

Light goes on when battery is not charging.

▲ If light goes on, stop engine and check engine belt.

10 Engine Hour Meter

11 Polarity Switch (Optional)

12 Constant Current/Constant Voltage (CC/CV) Switch

Use switch to select type of weld output. Use CC for Stick (SMAW) welding. Use CV for wire feed processes (MIG, FCAW). If using CV, place Ampere Range switch in maximum position.

13 Output/Contactor Switch

▲ Weld output terminals are energized when Output/Contactor switch is On and engine is running

Use switch to control remote contactor connected to Remote 14 receptacle RC3 or terminal strip 2T.

For weld output, place switch in the On position. Open-circuit voltage is present at the weld output terminals whenever engine is running.

For remote output control, place switch in Remote position. Open-circuit voltage is present at the weld output terminals when remote contactor switch is closed.

14 Amperage/Voltage Control Switch

Use switch to select front panel or remote amperage and voltage adjustment.

For front panel control, place switch in Panel position. For remote control, place switch in Remote position and connect remote control to Remote 14 receptacle RC3 or terminal strip 2T.

Example: Combination Remote Amperage Control

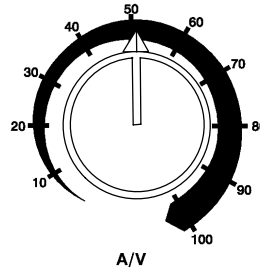
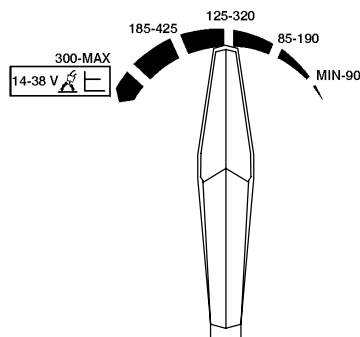
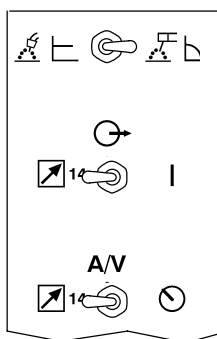

In Example:
Mode = CC
Range = 125 to 320 A DC
Percentage Of Range = 50%
Min = 125 A DC
Max = 223 A DC
(50% of 140 to 325)

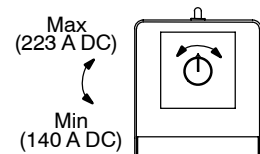

Set Switches



Set Range



Set Percentage



Adjust Remote Control

SECTION 6 – OPERATING AUXILIARY EQUIPMENT

6-1. 120 Volt And 240 Volt Duplex Receptacles

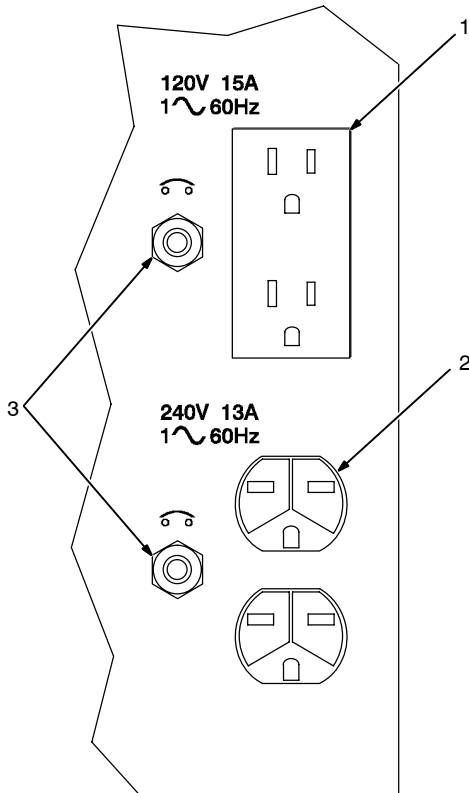

▲ If unit does not have GFCI receptacles, use GFCI-protected extension cord.

- 1 120 V 15 A AC Receptacle RC2
- 2 240 V 15 A AC Receptacle RC1

Receptacles supply 60 Hz single-phase power at weld/power speed.

- 3 Circuit Breakers CB1 And CB2

CB1 and CB2 protect RC1 and RC2 from overload. If CB1 or CB2 opens, RC1 and one half of RC2 does not work. 120 volts may still be present at RC1. Press button to reset breaker.

☞ If a circuit breaker continues to open, contact Factory Authorized Service Agent.

Maximum output from each duplex receptacle is 1.8 kVA/kW, and 3 kVA/kW from all receptacles.

☞ Auxiliary power is not affected by weld output.

EXAMPLE: If 10 A is drawn from RC1, only 5 A is available at RC2:
 $(240\text{ V} \times 10\text{ A}) + (120\text{ V} \times 5\text{ A}) = 3.0\text{ kVA/kW}$

6-2. Optional Auxiliary Power Receptacles

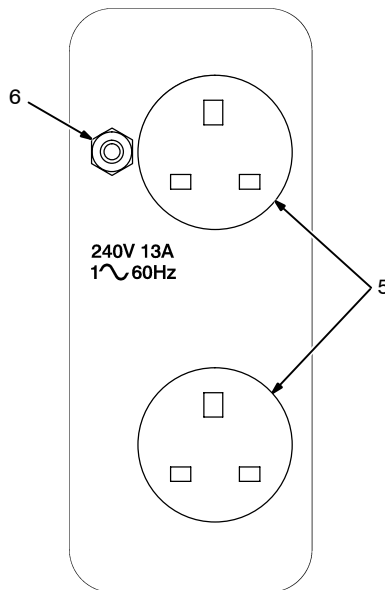
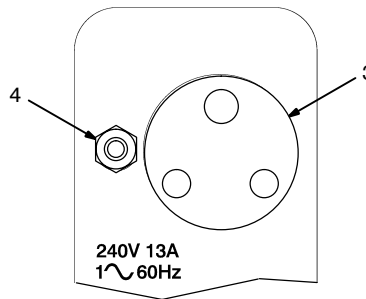
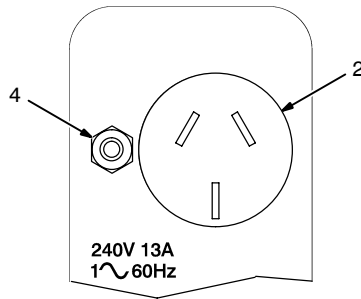
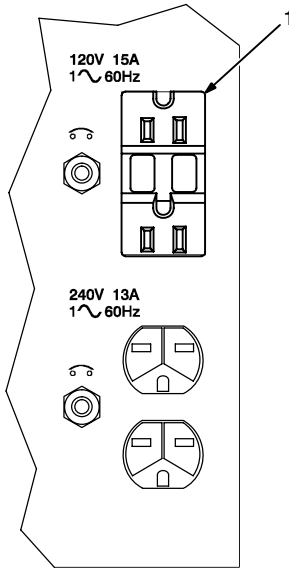

☞ Auxiliary power is not affected by weld output.

If a circuit breaker continues to open, contact Factory Authorized Service Agent.

GFCI Receptacle Option

- 1 120 V 15 A AC GFCI Receptacle GFCI1

Auxiliary power output and circuit breaker protection is the same as standard receptacles (see Section 6-1).

If a ground fault is detected, GFCI Reset button pops out and receptacle does not work. Check for faulty tools plugged in receptacle. Press button to reset.

☞ At least once a month, run engine at weld/power speed and press test button to verify GFCI is working properly.

Australian And South African Receptacle Options

- 2 240 V 10 A AC Australian Receptacle RC1
- 3 240 Volt 13 A AC South African Receptacle RC1

RC1 supplies 60 Hz single-phase power at weld/power speed. Maximum output from receptacle is 3 kVA/kW.

- 4 Circuit Breaker CB1

CB1 protects RC1 from overload. If CB1 opens, RC1 does not work. Press button to reset breaker.

British Receptacle Option

- 5 240 Volt 13 A AC British Receptacles RC1 And RC2

RC1 and RC2 supply 60 Hz single-phase power at weld/power speed. Maximum combined output from both receptacles is 3 kVA/kW.

- 6 Circuit Breaker CB1

CB1 protects RC1 and RC2 from overload. If CB1 opens, the receptacles do not work. Press button to reset breaker.

6-3. Connecting Optional Auxiliary Power Plant



- ▲ Stop engine.
- ▲ Power and weld outputs are live at the same time. Disconnect or insulate unused cables.

Have qualified person install according to circuit diagram and Auxiliary Power Guidelines Booklet (M176 712).

Remove junction box cover.

- 1 Lead 93
- 2 Lead 92
- 3 Lead 91
- 4 Lead 90 (Neutral)
- 5 Lead 42 (Circuit Grounding Lead)

Lead 42 connects to front panel Ground stud.

- 6 Grounding Terminal
- 7 Jumper Lead 42

- 8 Isolated Neutral Terminal

Jumper 42 is connected to lead 90 at factory. Jumper 42 may be disconnected from neutral to meet applicable electrical codes.

- 9 User-Supplied Leads

- 10 Load Terminals

Connect leads to terminals.

- 11 Fuses F1, F2, And F3

F1, F2, and F3 protect each load line from overload.

Set Engine Control switch to Run when using auxiliary power.

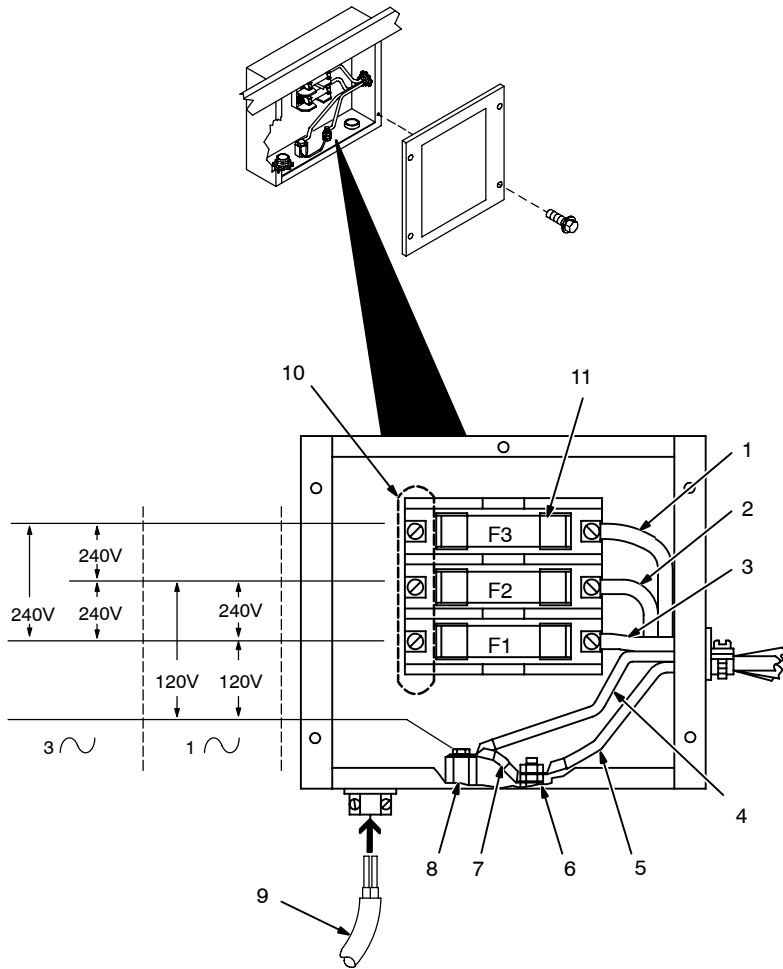

AC ~ Output	Single Phase 1 ~	Three Phase 3 ~
Volts	120/240	240
Amps	31	24
KVA/KW	7.5	10
Frequency	60 Hz	
Engine Speed	1850 RPM	
Max. Fuse Size	35 Amperes	

Lead 42 connects to GROUND stud on front of unit.
Jumper 42 is connected to 90 at factory.

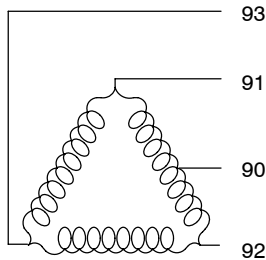

Tools Needed:

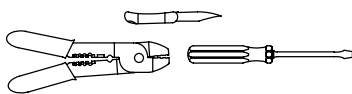









SECTION 7 – MAINTENANCE & TROUBLESHOOTING

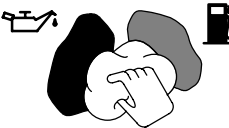
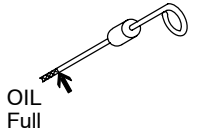



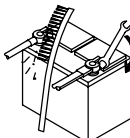
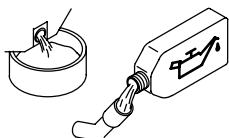
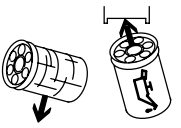

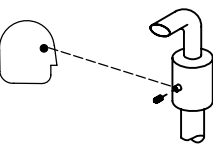
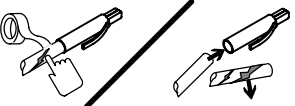
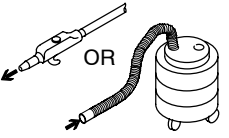
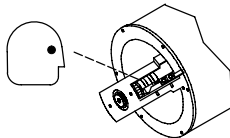
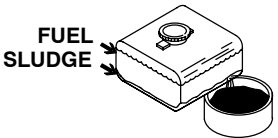
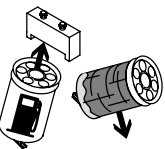
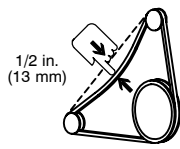
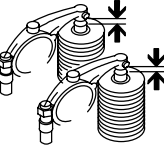



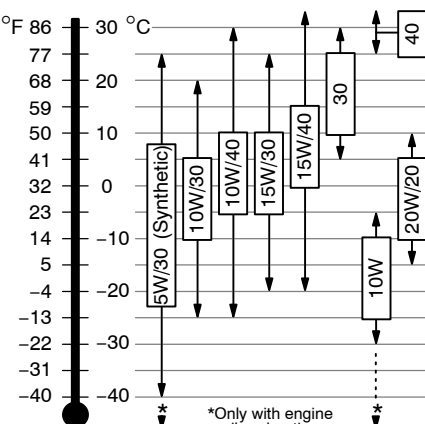

7-1. Routine Maintenance

NOTE 

Follow the storage procedure in the engine owner's manual if the unit will not be used for an extended period.

		 Recycle engine fluids.		<p>▲ Stop engine before maintaining.</p> <p> See also Engine Manual and Maintenance Label. Service engine more often if used in severe conditions.</p> <p>* To be done by Factory Authorized Service Agent.</p>	
8 h					
 Wipe Up Spills.		 OIL Full		 Check Fluid Levels. See Section 4-5.	
				 FUEL WATER Drain Water From Fuel System.	
50 h					
 Clean Air Filter. See Section 7-3.				 Clean And Tighten Weld Terminals.	
100 h					
 Clean And Tighten Battery Connections.		 Change Oil. See Section 7-4.		 Change Oil Filter. See Section 7-4.	
200 h			250 h		
 Replace Unreadable Labels.				 Check And Clean Spark Arrestor. See Section 7-9.	
500 h					
		 Repair Or Replace Cracked Cables.			
1000 h					
 Blow Out Or Vacuum Inside. During Heavy Service, Clean Monthly.		 Service Welding Generator Brushes And Slip Rings. Service More Often In Dirty Conditions.*		 FUEL SLUDGE Drain Sludge From Fuel Tank. See Section 7-4.	
 Change Fuel Filters. See Section 7-4.		 1/2 in. (13 mm) Check Belt Tension. See Section 7-7.		 Check Valve Clearance.*	

7-2. Maintenance Label

DEUTZ F3L912 DIESEL ENGINE	
	<p>See Engine Manual for complete engine care. Give Engine Specification and Serial Number when ordering parts.</p>
 <p><i>Check daily.</i></p>	
<p>Recommended Oil . . . API Service Classification CD/CE (or better) Oil Change & Filter . . . dirty conditions 100 hours or less normal conditions 125-150 hours Oil Filter MILLER 064 677, Deutz 117-4418, Fram PH6923 Oil Capacity 8.5 qt (8 L) or 9 qt (8.5 L) with filter change</p>	
 <p><i>Diesel</i></p>	<p>Fuel Capacity 23 gal (87 L) Fuel Grade 1-D or 2-D Cetane No. 45 min. Secondary Fuel Filter MILLER 064 686, Deutz 117-4423, Fram P4102 Primary Fuel Filter/ Water Separator MILLER 062 342, Fram P1107 <i>Fill filter with clean fuel before installing – read instructions on filter.</i></p>
	<p>Air Filter Service 50 hours or less – see Owner’s Manual Air Filter Element MILLER 020 319, Donaldson P181052, Fram CAK 253</p>
	<p>Blower Belt MILLER 064 690, Deutz 223-5531, Gates N7500 <i>Avoid recirculation of air from hot air exit to blower intake.</i></p>
	<p>Battery BCI Group 31 Cranking Performance at 0°F (-18°C) 800 Amps</p>
	<p>Alternator Belt Gates 7425, Deutz 0223-5179</p>
	<p>Engine RPM – No Load Weld 1850</p>
	<p>Valve Clearance – Cold Intake . . . 0.006 in (0.15 mm) Exhaust . 0.006 in (0.15 mm)</p>
	<p><i>Have only trained technician maintain injection pump and injectors. AIR, WATER, or GASOLINE will harm the injection system. If engine has run out of fuel or fuel filter is changed, bleeding of air may be required. Check engine manual for proper procedure.</i></p> <p><i>Injectors should be checked annually.</i></p>
	<p>Spark Arrestor Inspection And Service 250 operating hours – see Owner’s Manual</p>

S-181 642-B

7-3. Servicing Air Cleaner

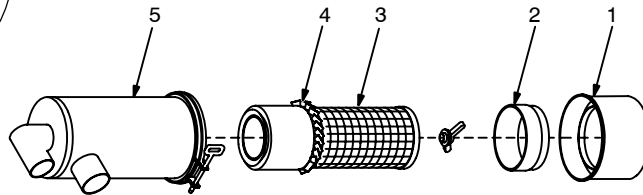
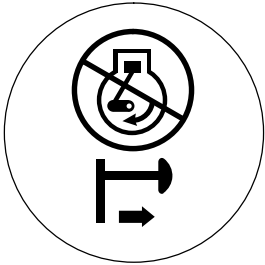

▲ **Stop engine.**

▲ **Do not run engine without air cleaner or with dirty element.**

Clean or replace element if dirty or damaged. Replace element yearly or after six cleanings.

1 Dust Cap

2 Baffle

3 Element

4 Plastic Fins

5 Housing

To clean air filter:

Wipe off cap and housing. Remove cap and dump out dust. Wipe dust from inside cap and housing with damp cloth. Remove element and reinstall cap.

▲ **Do not clean housing with air hose.**

Clean element with compressed air only. Keep nozzle at least 1 in (25 mm) from inside of element. Max. air pressure: 100 psi (690 kPa). Do not remove plastic fins. Replace element if it has holes or damaged gaskets.

Reinstall element and cap (cap arrows pointing up).

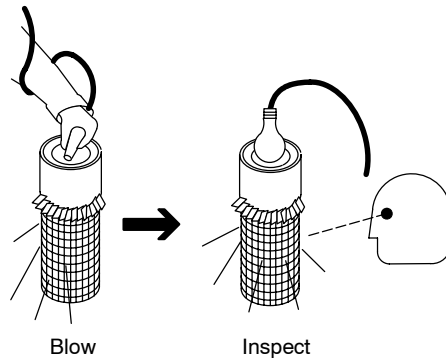

Blow

Inspect

aircleaner1 4/96 - ST-153 929-B / ST-153 585 / Ref. ST-180 933-B / Ref. S-0698-B

7-4. Servicing Fuel And Lubrication Systems

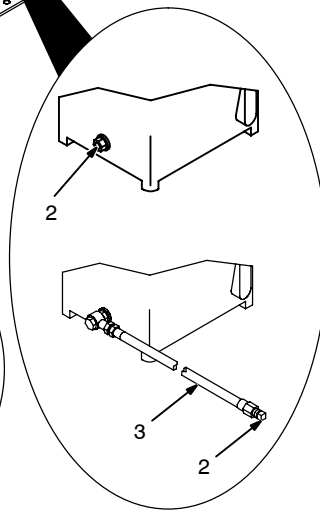
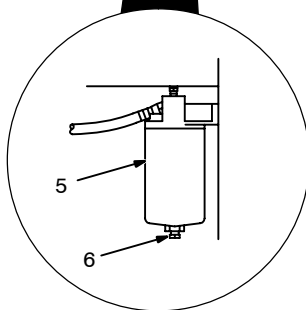
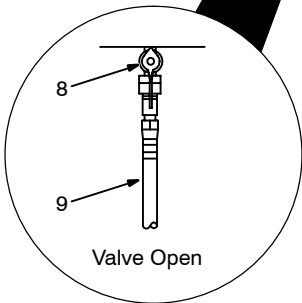
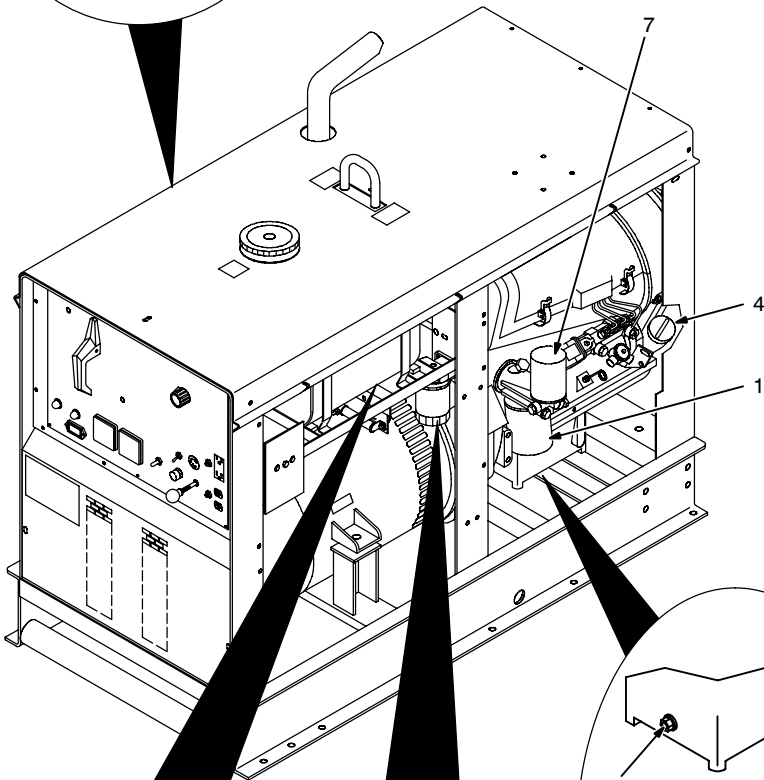
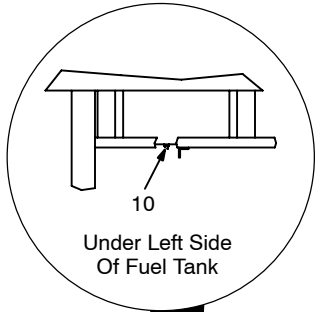
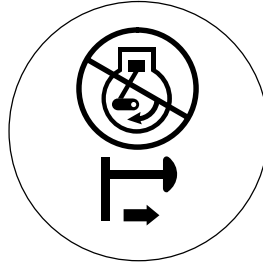
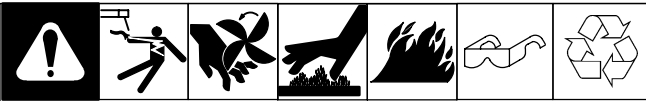

▲ Stop engine and let cool.

- 1 Oil Filter
- 2 Oil Drain Plug
- 3 Oil Drain Hose (Optional)
- 4 Oil Fill Cap
- 5 Primary Fuel Filter (Fuel/Water Separator)
- 6 Petcock
- 7 Secondary Fuel Filter
- 8 Fuel Shutoff Valve
- 9 Fuel Line
- 10 Sludge Drain Plug

To change oil and filter:

See engine manual.

To drain water from fuel system:

Open primary fuel filter petcock and drain water into metal container. Close petcock when water-free fuel flows.

To replace primary fuel filter:

Close shutoff valve and turn filter counterclockwise. Remove filter.

Apply thin coat of fuel to gasket on new filter. Install new filter and turn clockwise. Open shutoff valve. Bleed air from fuel system according to engine manual.

Inspect fuel line, and replace if cracked or worn.

To replace secondary fuel filter:

See engine manual.

To drain sludge from fuel tank:

Put metal container under drain, and remove sludge drain plug. Re-install plug when done.

▲ After servicing, start engine and check for fuel leaks.

▲ Stop engine, tighten connections as necessary, and wipe up spilled fuel.

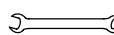

Close doors.

Tools Needed:

 3/8, 7/16, 3/4 in

7-5. Adjusting Engine Speed



Engine Speed (No Load)		RPM
Weld/Power		1850

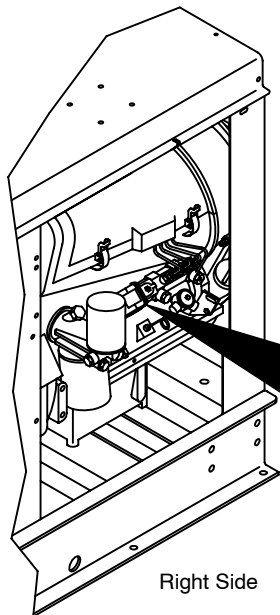

Right Side

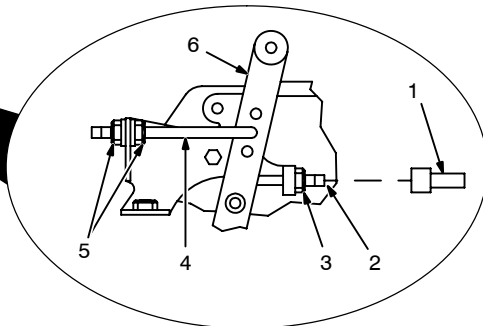

Tools Needed:

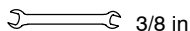

3/8 in

Engine speed is factory set and should not require adjustment. After tuning engine, check engine speed with tachometer. See table for proper no load speed. If necessary, adjust speed as follows:

- 1 Plastic Cap
- 2 High Speed Stop Screw
- 3 Lock Nut

Remove plastic cap from screw. Loosen nut. Turn screw out (toward front of engine) several turns.

- 4 Linkage
- 5 Lock Nuts

Loosen nuts. Start engine and move linkage until engine runs at weld/power speed. Tighten nuts.

▲ Stop engine.

- 6 Speed Control Lever

Turn screw in until screw touches lever. Tighten lock nut on screw and reinstall plastic cap.

Close side door.

ST-045 768-B

7-6. Servicing Optional Ether Starting Aid

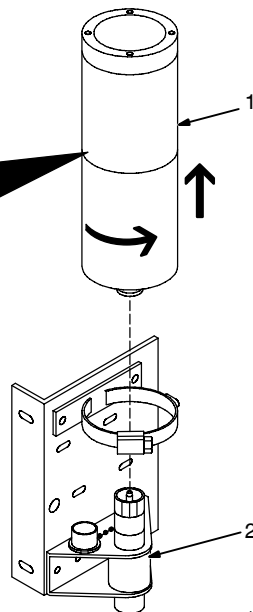
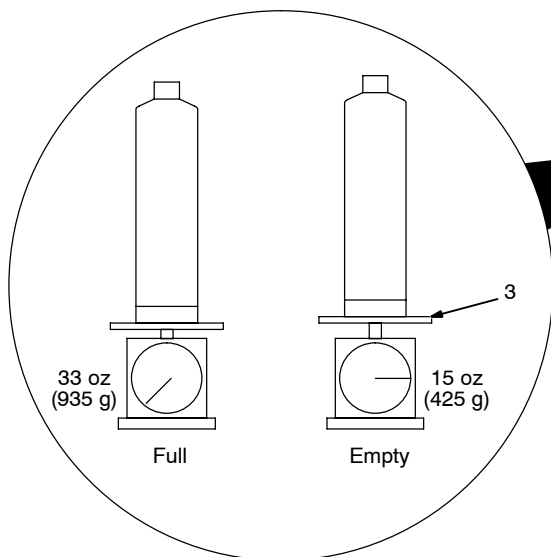
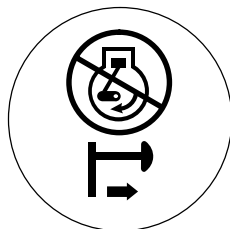

▲ Stop engine.

▲ Improper handling or exposure to ether can harm your health. Follow manufacturer's safety instructions on cylinder.

If engine does not start in cold weather, check ether cylinder as follows:

Remove cylinder from valve.

- 1 Ether Cylinder
- 2 Valve
- 3 Scale

Weigh cylinder to see if it is empty.

Be sure atomizer is not plugged and valve fitting is clean.

Replace cylinder according to Section 4-8.

ether2 7/96 - ST-153 382-A / Ref. ST-180 933-B / S-0692

7-7. Checking And Replacing Alternator Belt

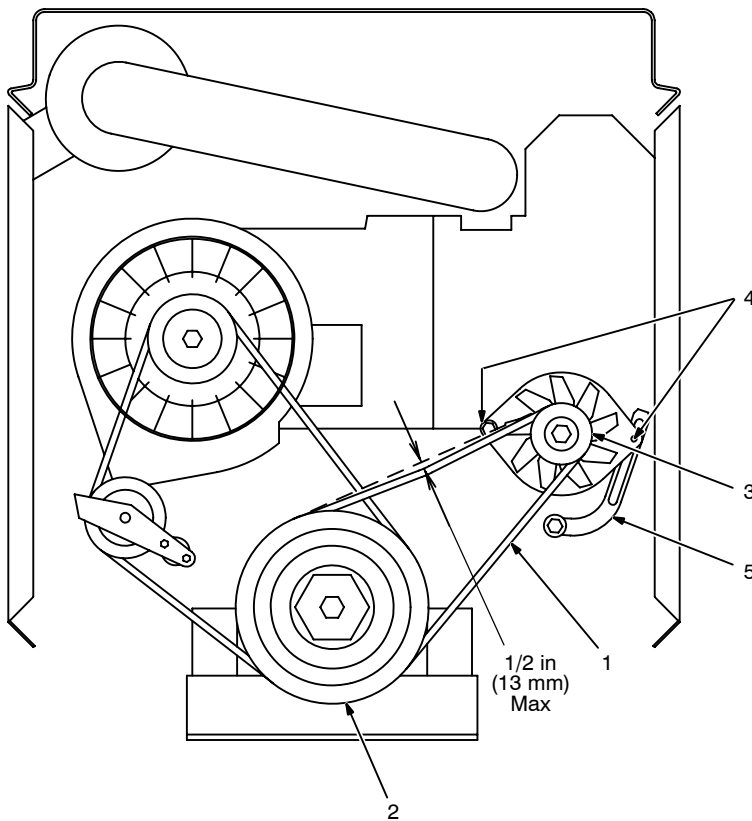
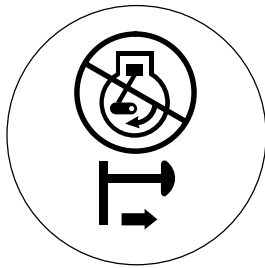

▲ Stop engine.

To check belt tension:

Remove rear panel.

- 1 Alternator V-Belt
- 2 Crank Pulley
- 3 Alternator Pulley

Place straight edge along top of pulleys. Pull down belt as far as it will go, then measure distance from belt to straight edge.

If measurement is less than 1/2 in (13 mm), belt is okay. If not okay, adjust belt tension.

To adjust belt tension:

- 4 Hex Nuts (2)
- 5 Alternator Bracket

Loosen nuts. Pivot alternator until belt is tight. Tighten nuts. Recheck tightness of belt. Readjust if necessary.

Replace belt if damaged or cracked.

To replace belt:

Loosen hex nuts and pivot alternator clockwise. Remove belt.

Install new belt, pivot alternator until belt is tight, and tighten nuts. Recheck tightness of belt after running engine 15 minutes.

Reinstall rear panel.

Tools Needed:

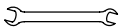
 1/2, 11/16 in

7-8. Resetting Fan Belt Safety Shutdown

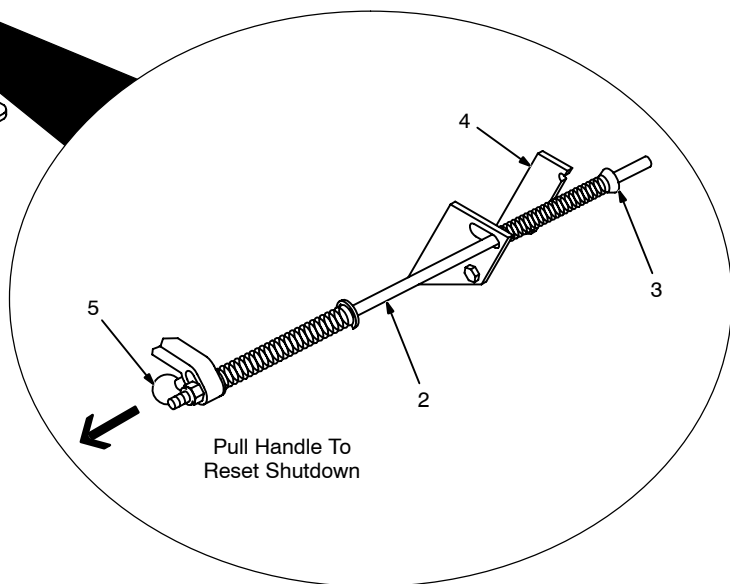
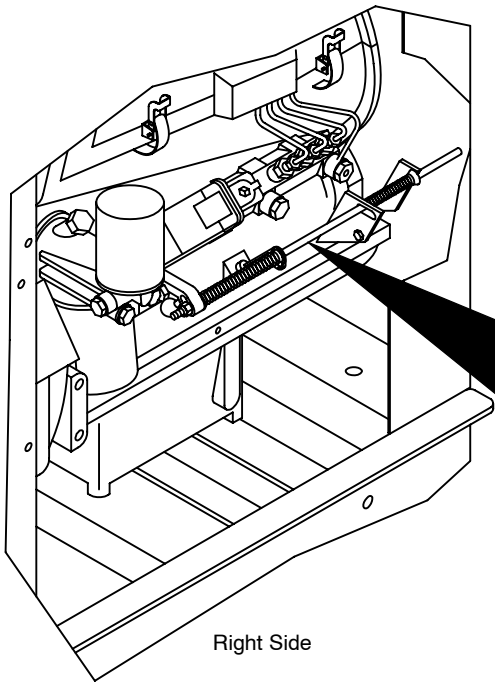
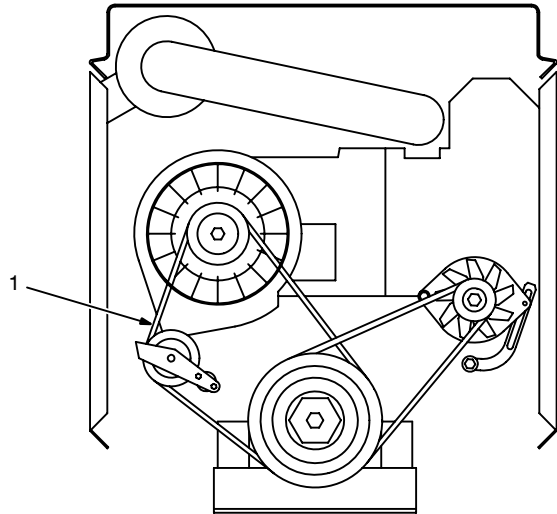
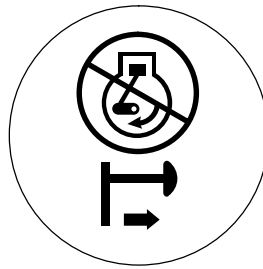

▲ Stop engine.

1 Cooling Fan V-Belt

See engine manual to replace or tighten belt.

If belt breaks or becomes loose, safety shutdown stops engine.

Correct problem, then reset safety shutdown as follows:

- 2 Rod
- 3 Stop
- 4 Bracket
- 5 Handle

Pull handle towards front of unit until stop snaps in position behind bracket.

Close door.

Tools Needed:

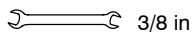
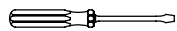

7-9. Inspecting And Cleaning Optional Spark Arrestor Muffler

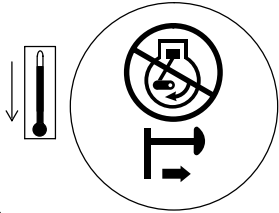
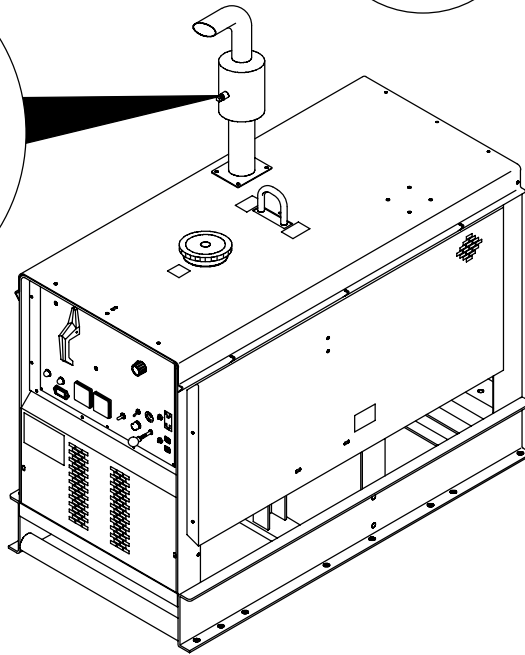
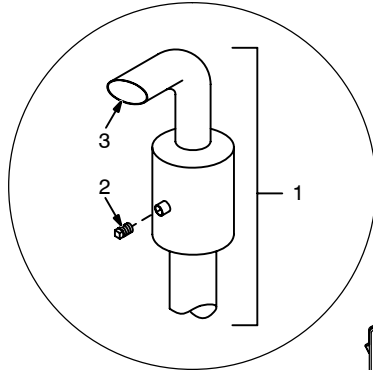

▲ Stop engine and let cool.

- 1 Spark Arrestor Muffler
- 2 Cleanout Plug
- 3 Exhaust Pipe

Remove plug and remove any dirt covering cleanout hole.

Start engine and run at idle speed to blow out cleanout hole. If nothing blows out of hole, briefly cover end of exhaust pipe with fireproof material.

▲ Stop engine and let cool.

Reinstall cleanout plug.

Tools Needed:

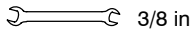

ST-800 633-B / Ref. ST-180 933-B

7-10. Overload Protection For Models With CV Option

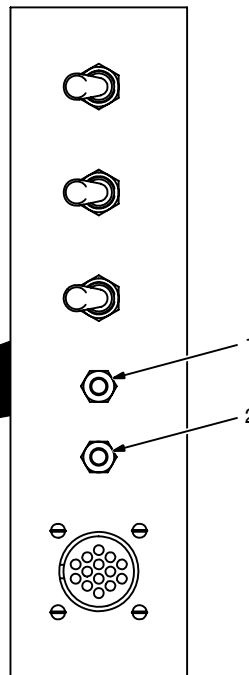
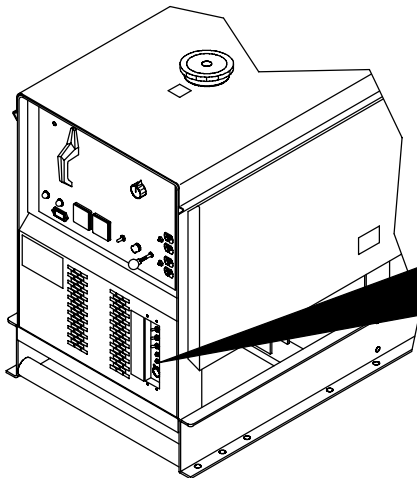

1 Circuit Breaker CB3

CB3 protects the 115 volt ac output to Remote receptacle RC3 and terminal strip 2T.

If CB3 opens, the 115 volt ac output stops.

2 Circuit Breaker CB4

CB4 protects the 24 volts ac output to Remote receptacle RC3 and terminal strip 2T.

If CB3 opens, the 24 volt ac output stops.

Press button to reset circuit breaker. If a breaker continues to open, contact Factory Authorized Service Agent.

ST-800 862-A / ST-148 404

7-11. Troubleshooting

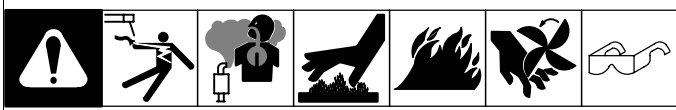

A. Welding

Trouble	Remedy
No weld output.	Check position of Ampere Range switch.
	Check position of optional polarity switch.
	Disconnect equipment from auxiliary power receptacles during start-up.
	Place A/V Control switch in Panel position, or place switch in Remote position and connect remote control to Remote A/V Control receptacle RC3 (see Sections 4-9 and 5-1).
	Check and secure connections to Remote A/V Control receptacle RC3 (see Section 4-9).
	Place optional Output/Contactor Control switch in On position, or place switch in Remote position and connect remote contactor to optional Remote 14 receptacle RC3 or terminal strip 2T (see Sections 4-10 and 4-11).
	Have Factory Authorized Service Agent check brushes and slip rings, field excitation circuit, and optional field current regulator board PC1.
Erratic weld output.	Check and tighten connections inside and outside unit.
	Be sure connection to work piece is clean and tight.
	Use dry, properly stored electrodes.
	Remove excessive coils from weld cables.
	Check Ampere Range switch connections and contacts.
High or low weld output.	Check engine speed, and adjust if necessary (see Section 7-5).
	Check optional CC/CV switch position.
Low open-circuit voltage.	Check engine speed, and adjust if necessary (see Section 7-5).
	Check optional CC/CV switch position.
	Have Factory Authorized Service Agent check optional field current regulator board PC1 and CV regulator board PC2.
Maximum weld output only in each ampere range.	Have Factory Authorized Service Agent check Amperage/Voltage control R1, capacitor C8, diode D8, integrated rectifier SR4, control relay CR2, and optional CV regulator board PC2.
Wire feeder does not work (models with CV option).	Reset circuit breaker CB3 and/or CB4 (see Section 7-10).
	Check connections to optional Remote 14 receptacle RC3 and terminal strip 2T (see Sections 4-10 and 4-11).
	Repair or replace wire feeder.
No amperage control (or voltage control on models with CV option).	Place A/V Control switch in correct position.
	Check connections to optional Remote 14 receptacle RC3 and terminal strip 2T (see Sections 4-10 and 4-11).
	Repair or replace remote control device.
	Have Factory Authorized Service Agent check optional CV regulator board PC2.
Low CV weld output (models with CV option).	Set Ampere Range switch to highest range.
Min or max CV weld output only (models with CV option).	Check position of Amperage/voltage control and Amperage/Voltage Control switch.

Trouble	Remedy
	Repair or replace remote control device.
	Have Factory Authorized Service Agent check optional CV regulator board PC2.

B. Auxiliary Power

Trouble	Remedy
No output at auxiliary power receptacles.	Reset receptacle circuit breakers.
	Have Factory Authorized Service Agent check brushes and slip rings, and optional field current regulator board PC1.
High or low output at auxiliary power receptacles.	Check engine speed, and adjust if necessary (see Section 7-5).
No or low output at optional auxiliary power plant.	Check connections to auxiliary power plant (see Section 6-3).
	Check engine speed, and adjust if necessary (see Section 7-5).
	Place A/V Control switch in Panel position, or place switch in Remote position and connect remote control to Remote A/V Control receptacle RC3 (see Sections 4-9 and 5-1).
	Check fuses F1, F2, and F3 and replace as necessary (see Section 6-3).
	Set optional remote control at maximum (see Section 4-9 or 4-10).
	Place optional Output/Contactor Control switch in On position, or place switch in Remote position and connect remote contactor to optional Remote 14 receptacle RC3 or terminal strip 2T (see Sections 4-10 and 4-11).
	Place optional CC/CV switch in CC position (see Section 5-3).
High output at optional auxiliary power plant.	Have Factory Authorized Service Agent check brushes and slip rings, and optional field current regulator board PC1.
	Check engine speed, and adjust if necessary (see Section 7-5).
	Have Factory Authorized Service Agent check optional field current regulator board PC1.

C. Engine

Trouble	Remedy
Engine does not start.	Check fuel level (see Section 4-5).
	Open fuel valve (see Section 4-5).
	Check battery and replace if necessary.
	Check blower fan V-belt according to engine manual. Safety shutdown stops engine if belt is broken or loose (see Section 7-8).
	Check engine Start button and replace if necessary.
	Check engine charging system according to engine manual.
	See engine manual.
Engine suddenly stops.	Check blower fan V-belt according to engine manual. Safety shutdown stops engine if belt is broken or loose (see Section 7-8).
	See engine manual.
Battery discharges between uses.	Clean top of battery with baking soda and water solution; rinse with clear water.
	Recharge or replace battery if necessary.

Trouble	Remedy
	Periodically recharge battery (approximately every 3 months).
Engine uses oil during run-in period; wetstacking occurs.	Dry engine (see Section 9).

Notes

DECIMAL EQUIVALENTS

	$\frac{1}{64}$.015625
	$\frac{1}{32}$.03125
	$\frac{3}{64}$.046875
		.0625
$\frac{1}{16}$	$\frac{5}{64}$.078125
	$\frac{3}{32}$.09375
	$\frac{7}{64}$.109375
$\frac{1}{8}$.125
	$\frac{9}{64}$.140625
	$\frac{5}{32}$.15625
	$\frac{11}{64}$.171875
$\frac{3}{16}$.1875
	$\frac{13}{64}$.203125
	$\frac{7}{32}$.21875
	$\frac{15}{64}$.234375
$\frac{1}{4}$.25
	$\frac{17}{64}$.265625
	$\frac{9}{32}$.28125
	$\frac{19}{64}$.296875
$\frac{5}{16}$.3125
	$\frac{21}{64}$.328125
	$\frac{11}{32}$.34375
	$\frac{23}{64}$.359375
$\frac{3}{8}$.375
	$\frac{25}{64}$.390625
	$\frac{13}{32}$.40625
	$\frac{27}{64}$.421875
$\frac{7}{16}$.4375
	$\frac{29}{64}$.453125
	$\frac{15}{32}$.46875
	$\frac{31}{64}$.484375
$\frac{1}{2}$.5
	$\frac{33}{64}$.515625
	$\frac{17}{32}$.53125
	$\frac{35}{64}$.546875
$\frac{9}{16}$.5625
	$\frac{37}{64}$.578125
	$\frac{19}{32}$.59375
	$\frac{39}{64}$.609375
$\frac{5}{8}$.625
	$\frac{41}{64}$.640625
	$\frac{21}{32}$.65625
	$\frac{43}{64}$.671875
$\frac{11}{16}$.6875
	$\frac{45}{64}$.703125
	$\frac{23}{32}$.71875
	$\frac{47}{64}$.734375
$\frac{3}{4}$.75
	$\frac{49}{64}$.765625
	$\frac{25}{32}$.78125
	$\frac{51}{64}$.796875
$\frac{13}{16}$.8125
	$\frac{53}{64}$.828125
	$\frac{27}{32}$.84375
	$\frac{55}{64}$.859375
$\frac{7}{8}$.875
	$\frac{57}{64}$.890625
	$\frac{29}{32}$.90625
	$\frac{59}{64}$.921875
$\frac{15}{16}$.9375
	$\frac{61}{64}$.953125
	$\frac{31}{32}$.96875
	$\frac{63}{64}$.984375
1		1.

SECTION 8 - ELECTRICAL DIAGRAMS

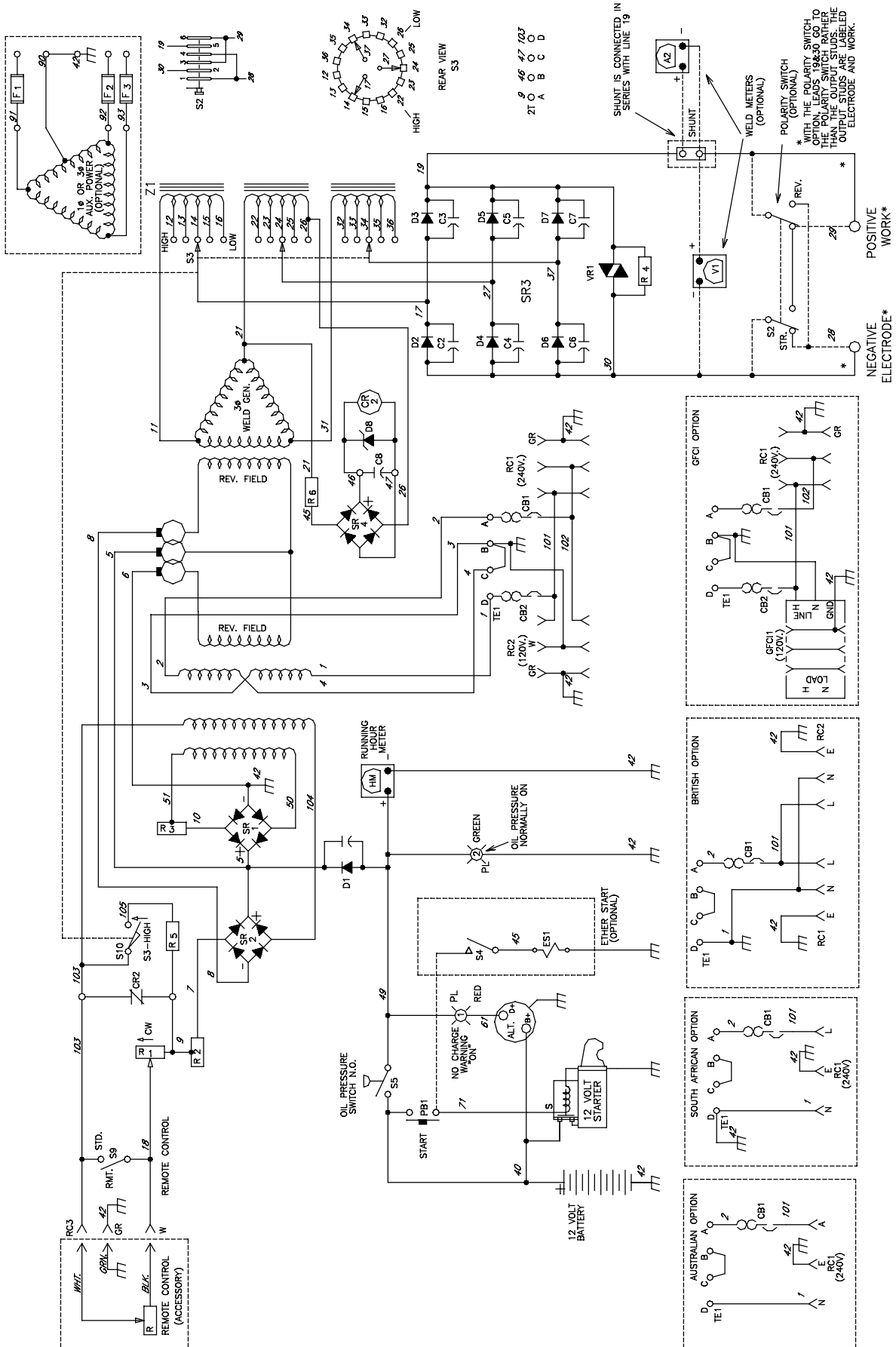

Figure 8-1. Circuit Diagram For Welding Generator (Standard Models)

PLG8/RC8
 18 → 1 → 18
 43 → 2 → 43
 52 → 3 → 52

PLG9/RC9
 52 → 1 → 52
 52 → 2 → 52
 56 → 3 → 56
 65 → 4 → 65

PLG10/RC10
 49 → 1 → 49
 40 → 2 → 40
 71 → 3 → 71
 → 4 →

PLG11/RC11
 18 → 1 → 18
 26 → 2 → 26
 54 → 3 → 54
 57 → 4 → 57

PLG20/RC20
 3 → 1 → 3
 5 → 2 → 5
 → 3 →
 3 → 4 → 3
 → 5 →
 18 → 6 → 18
 54 → 7 → 54
 43 → 8 → 43
 52 → 9 → 52

PLG21/RC21
 131 → 1 → 131
 59 → 2 → 59
 43 → 3 → 43
 18 → 4 → 18
 44 → 5 → 44
 3 → 6 → 3
 132 → 7 → 132
 42 → 8 → 42
 59 → 9 → 59

PLG22/RC22
 1 → 1 → 1
 → 2 →
 → 3 →
 103 → 4 → 103
 → 5 →
 104 → 6 → 104
 81 → 7 → 81
 → 8 →
 82 → 9 → 82
 130 → 10 → 130
 8 → 11 → 8
 → 12 →

A	B	C	D	E	F	A	B	C	D	E	G	I	K	J	A	B	C	
1T	0	0	0	0	0	2T	0	0	0	0	0	0	0	0	3T	0	0	0
3	5	6	8	18	131	59	43	18	44	3	132	42	59	81	82	130		

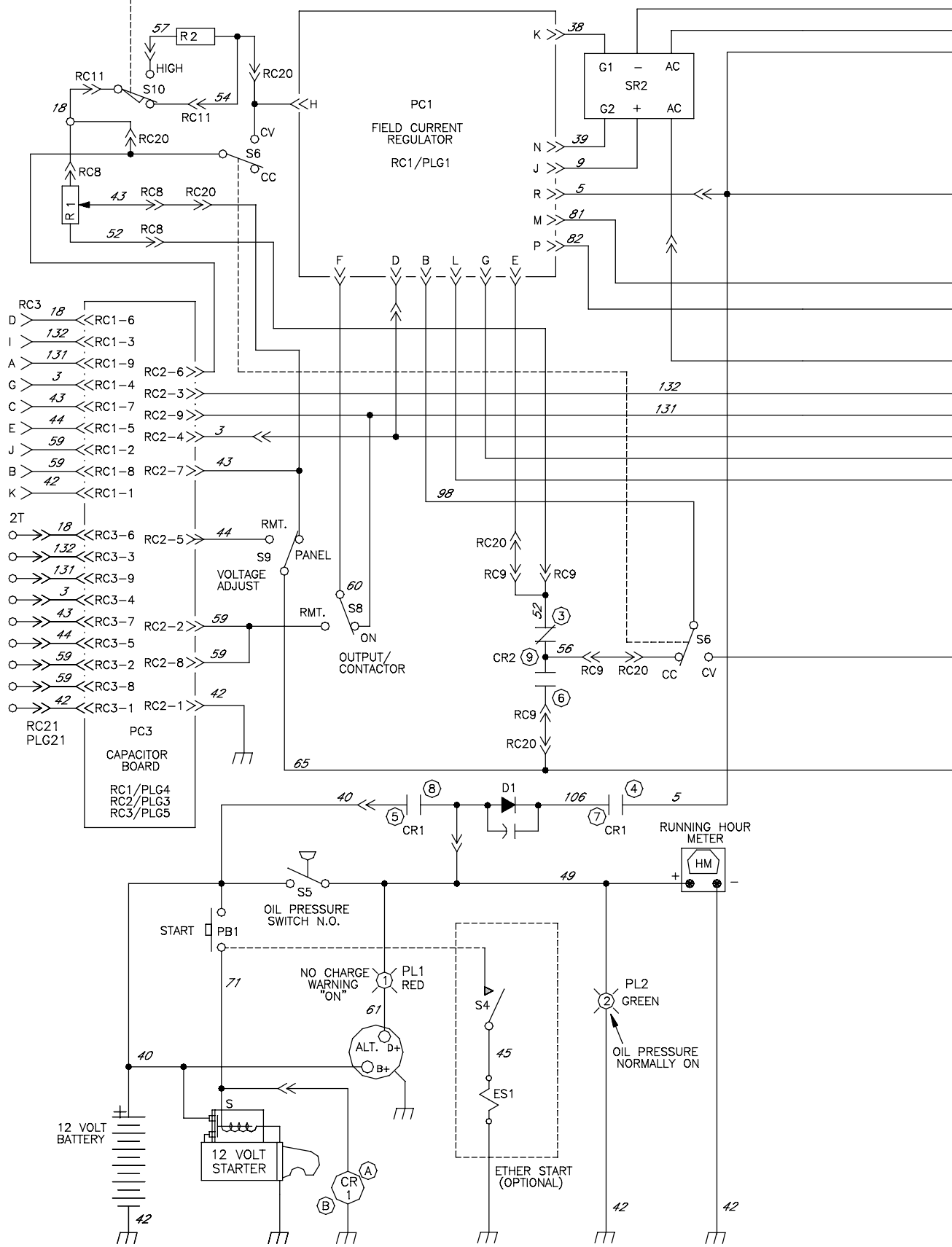
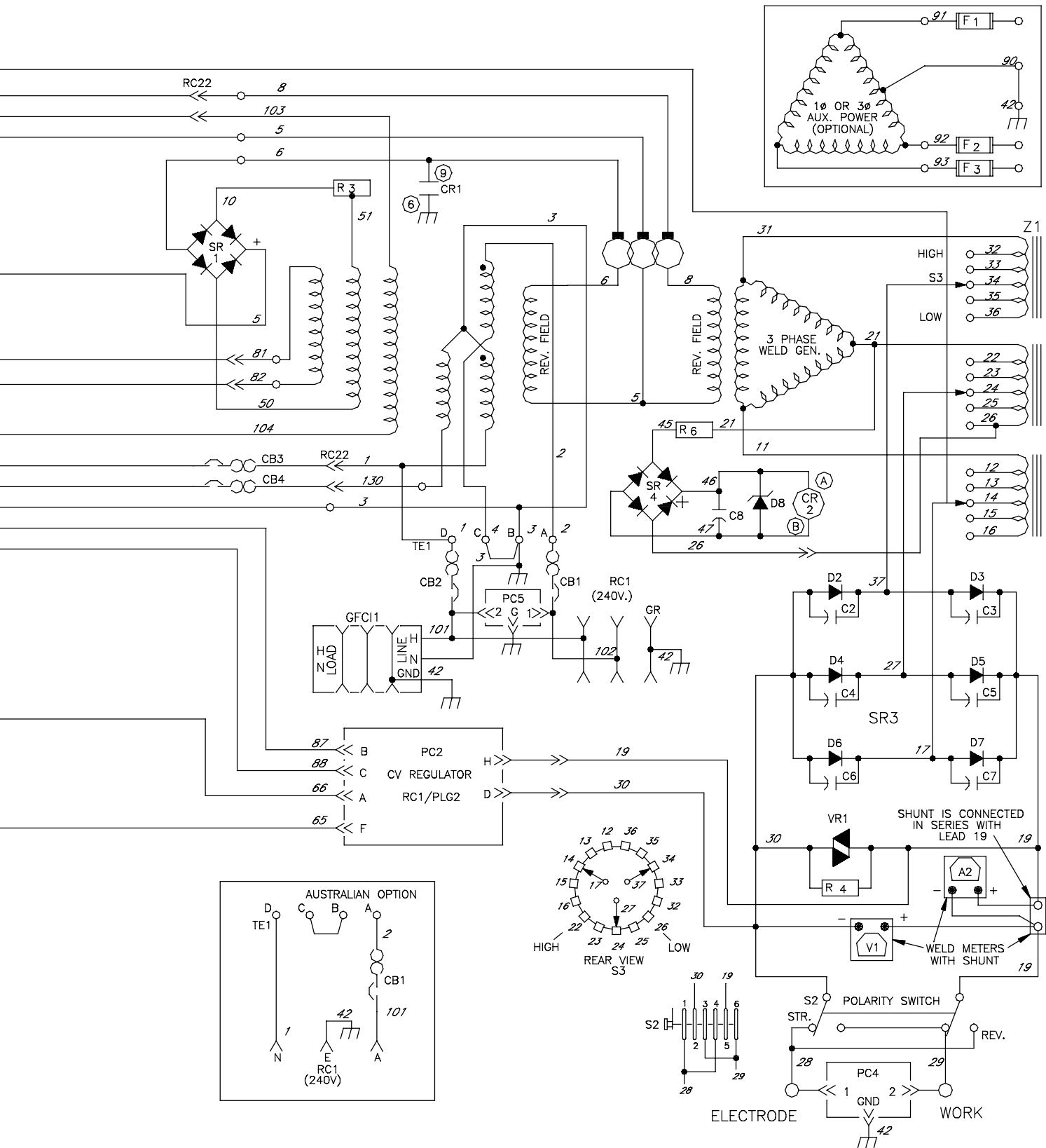

Figure 8-2. Circuit Diagram For Welding Generator (Models With CV Option)



SECTION 9 – RUN-IN PROCEDURE

run_in1 6/96

9-1. Wetstacking

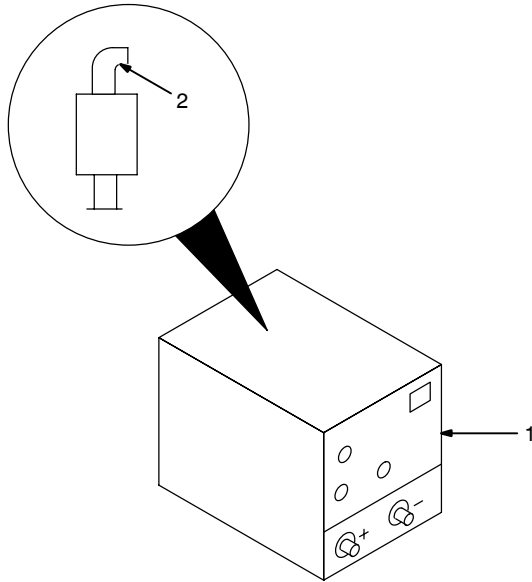

1 Welding Generator

Run diesel engines near rated output during run-in period to properly seat piston rings and prevent wetstacking. See nameplate or rating label to find rated output.

Do not idle engine longer than necessary. Piston rings seat faster if engine runs at weld/power rpm, and the welding generator is kept loaded during run-in.

2 Engine Exhaust Pipe

Wetstacking is unburned fuel and oil in the exhaust pipe and occurs during run-in if the engine is run too long at light load or idle rpm.

If exhaust pipe is coated with a wet, black, tar-like substance, dry the engine using one of the following run-in procedures.

See the engine manual for additional engine run-in information.

9-2. Run-In Procedure Using Load Bank

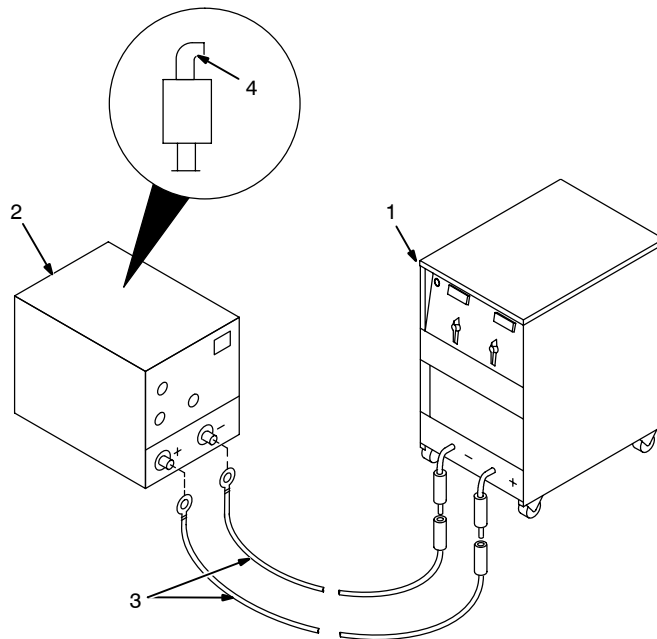

- ▲ **Stop engine.**
- ▲ **Do not touch hot exhaust pipe, engine parts, or load bank/grid.**
- ▲ **Keep exhaust and pipe away from flammables.**

1 Load Bank

Turn all load bank switches Off. If needed, connect load bank to 115 volts ac wall receptacle or generator auxiliary power receptacle.

2 Welding Generator

Place A/V range switch in maximum position, A/V control in minimum position, and Output Selector switch (if present) in either DC position.

3 Weld Cables

Connect load bank to generator weld output terminals using proper size weld cables with correct connectors. Observe correct polarity.

Start engine and run for several minutes.

Set load bank switches and then adjust generator A/V control so load equals rated generator output (see nameplate).

Check generator and load bank meters after first five minutes then every fifteen minutes to be sure generator is loaded properly.

☞ *Check oil level frequently during run-in; add oil if needed.*

After one hour (minimum) place A/V control in minimum position, then turn off load bank to remove load. Run engine several minutes at no load.

- ▲ **Stop engine and let cool.**

4 Engine Exhaust Pipe

Repeat procedure if wetstacking is present.

9-3. Run-In Procedure Using Resistance Grid

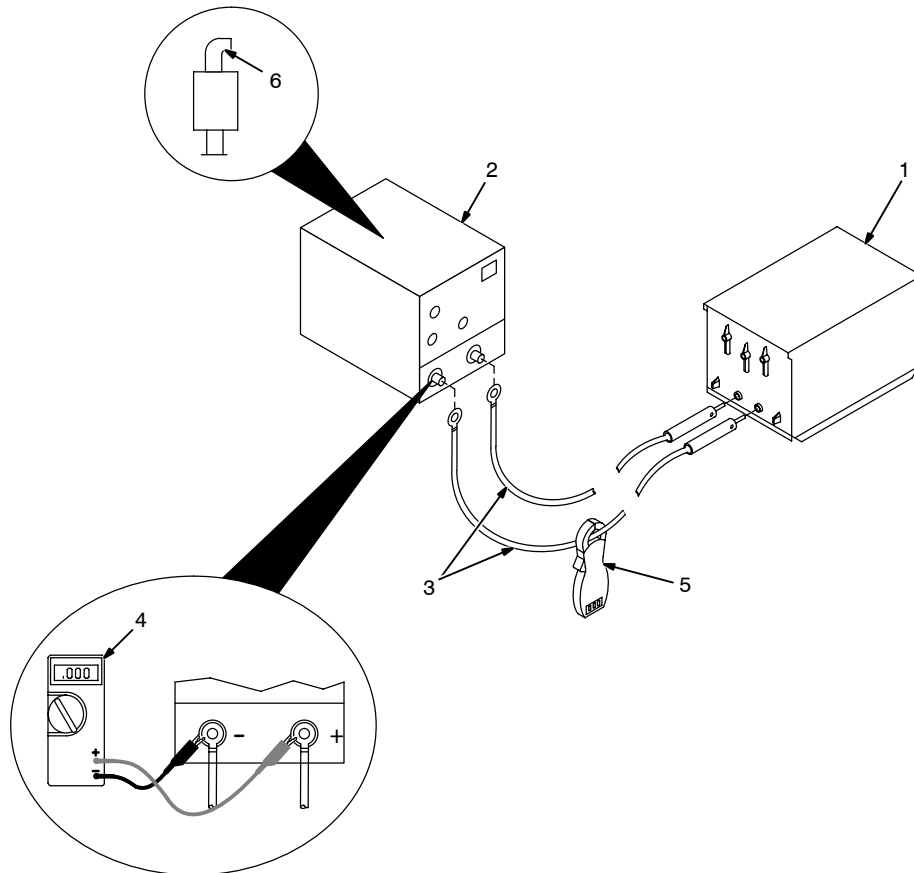

- ▲ **Stop engine.**
- ▲ **Do not touch hot exhaust pipe, engine parts, or load bank/grid.**
- ▲ **Keep exhaust and pipe away from flammables.**

1 Resistance Grid
Use grid sized for generator rated output.

Turn Off grid.

2 Welding Generator
Place A/V range switch in maximum position, A/V control in minimum position, and Output Selector switch (if present) in either DC position.

3 Weld Cables
Connect grid to generator weld output terminals using proper size weld cables with correct connectors (polarity is not important).

4 Voltmeter
5 Clamp-On Ammeter
Connect voltmeter and ammeter as shown, if not provided on generator.

Start engine and run for several minutes.

Set grid switches and then adjust generator A/V control so load equals rated generator output (see nameplate).

Check generator and meters after first five minutes then every fifteen minutes to be sure generator is loaded properly.

☞ *Check oil level frequently during run-in; add oil if needed.*



After one hour (minimum), place A/V control in minimum position, then shut down grid to remove load. Run engine several minutes at no load.

- ▲ **Stop engine and let cool.**

6 Engine Exhaust Pipe
Repeat procedure if wetstacking is present.

SECTION 10 – AUXILIARY POWER GUIDELINES

10-1. Selecting Equipment



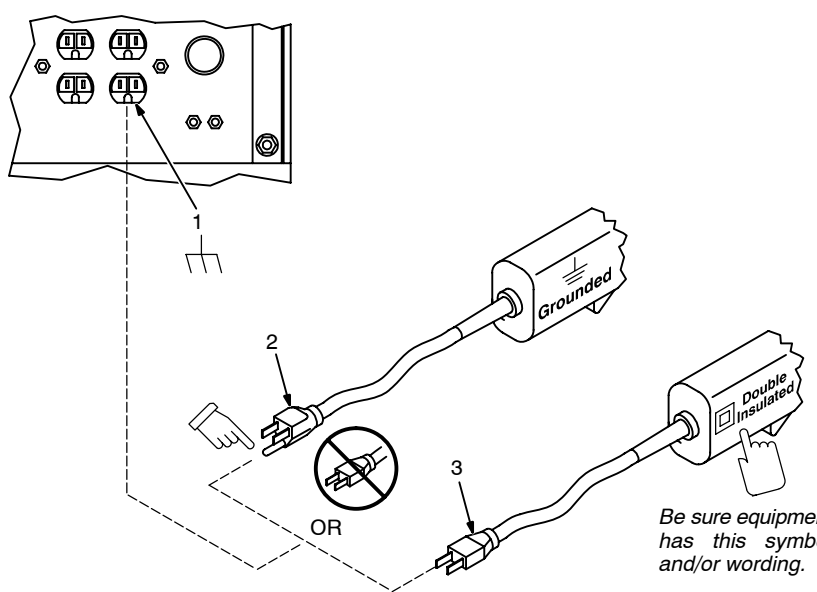



- 1 Auxiliary Power Receptacles – Neutral Bonded To Frame
- 2 3-Prong Plug From Case Grounded Equipment
- 3 2-Prong Plug From Double Insulated Equipment

aux_pwr 2/99 – Ref. ST-159 730 / ST-800 577

10-2. Grounding Generator To Truck Or Trailer Frame

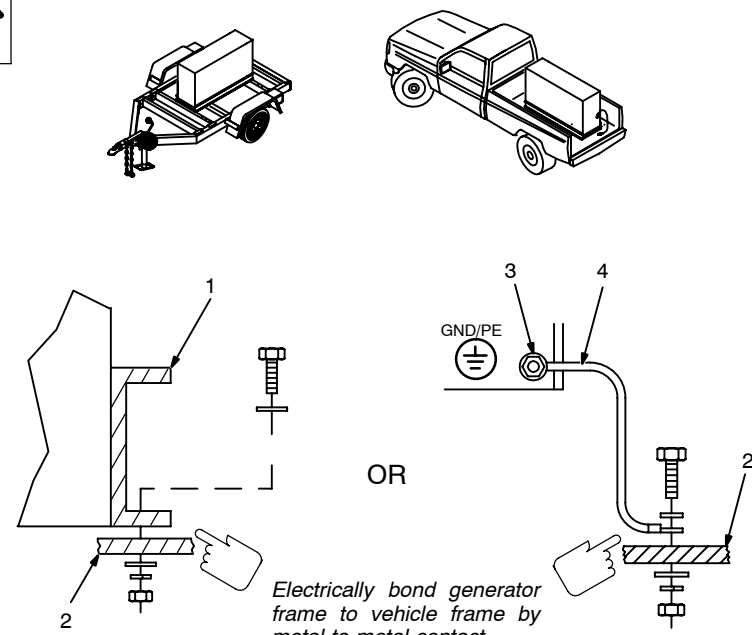

- 1 Generator Base
- 2 Metal Vehicle Frame
- 3 Equipment Grounding Terminal
- 4 Grounding Cable

Use #10 AWG or larger insulated copper wire.

▲ If unit does not have GFCI receptacles, use GFCI-protected extension cord.

S-0854

10-3. Grounding When Supplying Building Systems

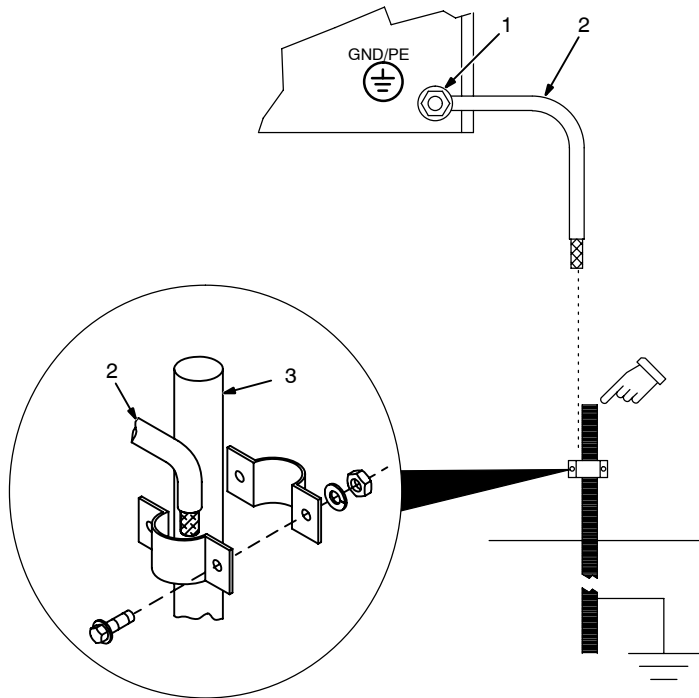

- 1 Equipment Grounding Terminal
 - 2 Grounding Cable
- Use #10 AWG or larger insulated copper wire.
- 3 Ground Device
- ▲ **Ground generator to system earth ground if supplying power to a premises (home, shop, farm) wiring system.**

Use ground device as stated in electrical codes.

ST-800 576-B

10-4. How Much Power Does Equipment Require?

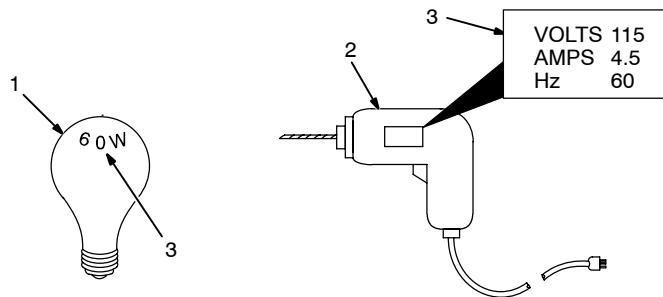

- 1 Resistive Load
- A light bulb is a resistive load and requires a constant amount of power.
- 2 Non-Resistive Load
- Equipment with a motor is a non-resistive load and requires approximately six times more power while starting the motor than when running (see Section 10-8).
- 3 Rating Data
- Rating shows volts and amperes, or watts required to run equipment.

AMPERES x VOLTS = WATTS

EXAMPLE 1: If a drill uses 4.5 amperes at 115 volts, calculate its running power requirement in watts.

$$4.5 \text{ A} \times 115 \text{ V} = 520 \text{ W}$$

The load applied by the drill is 520 watts.

EXAMPLE 2: If three 200 watt flood lamps are used with the drill from Example 1, add the individual loads to calculate total load.

$$(200 \text{ W} + 200 \text{ W} + 200 \text{ W}) + 520 \text{ W} = 1120 \text{ W}$$

The total load applied by the three flood lamps and drill is 1120 watts.

S-0623

10-5. Approximate Power Requirements For Industrial Motors

Industrial Motors	Rating	Starting Watts	Running Watts
Split Phase	1/8 HP	800	300
	1/6 HP	1225	500
	1/4 HP	1600	600
	1/3 HP	2100	700
	1/2 HP	3175	875
Capacitor Start-Induction Run	1/3 HP	2020	720
	1/2 HP	3075	975
	3/4 HP	4500	1400
	1 HP	6100	1600
	1-1/2 HP	8200	2200
	2 HP	10550	2850
	3 HP	15900	3900
	5 HP	23300	6800
	1-1/2 HP	8100	2000
Capacitor Start-Capacitor Run	5 HP	23300	6000
	7-1/2 HP	35000	8000
	10 HP	46700	10700
Fan Duty	1/8 HP	1000	400
	1/6 HP	1400	550
	1/4 HP	1850	650
	1/3 HP	2400	800
	1/2 HP	3500	1100

10-6. Approximate Power Requirements For Farm/Home Equipment

Farm/Home Equipment	Rating	Starting Watts	Running Watts
Stock Tank De-Icer		1000	1000
Grain Cleaner	1/4 HP	1650	650
Portable Conveyor	1/2 HP	3400	1000
Grain Elevator	3/4 HP	4400	1400
Milk Cooler		2900	1100
Milker (Vacuum Pump)	2 HP	10500	2800
FARM DUTY MOTORS	1/3 HP	1720	720
Std. (e.g. Conveyors,	1/2 HP	2575	975
Feed Augers, Air	3/4 HP	4500	1400
Compressors)	1 HP	6100	1600
	1-1/2 HP	8200	2200
	2 HP	10550	2850
	3 HP	15900	3900
	5 HP	23300	6800
High Torque (e.g. Barn	1-1/2 HP	8100	2000
Cleaners, Silo Unloaders,	5 HP	23300	6000
Silo Hoists, Bunk Feeders)	7-1/2 HP	35000	8000
	10 HP	46700	10700
3-1/2 cu. ft. Mixer	1/2 HP	3300	1000
High Pressure 1.8 Gal/Min	500 PSI	3150	950
Washer 2 gal/min	550 PSI	4500	1400
2 gal/min	700 PSI	6100	1600
Refrigerator or Freezer		3100	800
Shallow Well Pump	1/3 HP	2150	750
	1/2 HP	3100	1000
Sump Pump	1/3 HP	2100	800
	1/2 HP	3200	1050

10-7. Approximate Power Requirements For Contractor Equipment

Contractor	Rating	Starting Watts	Running Watts
Hand Drill	1/4 in	350	350
	3/8 in	400	400
	1/2 in	600	600
Circular Saw	6-1/2 in	500	500
	7-1/4 in	900	900
	8-1/4 in	1400	1400
Table Saw	9 in	4500	1500
	10 in	6300	1800
Band Saw	14 in	2500	1100
Bench Grinder	6 in	1720	720
	8 in	3900	1400
	10 in	5200	1600
Air Compressor	1/2 HP	3000	1000
	1 HP	6000	1500
	1-1/2 HP	8200	2200
	2 HP	10500	2800
Electric Chain Saw	1-1/2 HP, 12 in	1100	1100
	2 HP, 14 in	1100	1100
Electric Trimmer	Standard 9 in	350	350
	Heavy Duty 12 in	500	500
Electric Cultivator	1/3 HP	2100	700
Elec. Hedge Trimmer	18 in	400	400
Flood Lights	HID	125	100
	Metal Halide	313	250
	Mercury	1000	
	Sodium	1400	
	Vapor	1250	1000
Submersible Pump	400 gph	600	200
Centrifugal Pump	900 gph	900	500
Floor Polisher	3/4 HP, 16 in	4500	1400
	1 HP, 20 in	6100	1600
High Pressure Washer	1/2 HP	3150	950
	3/4 HP	4500	1400
	1 HP	6100	1600
55 gal Drum Mixer	1/4 HP	1900	700
Wet & Dry Vac	1.7 HP	900	900
	2-1/2 HP	1300	1300

10-8. Power Required To Start Motor

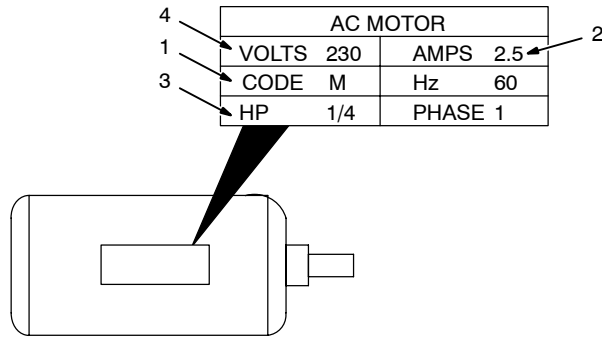

- 1 Motor Start Code
- 2 Running Amperage
- 3 Motor HP
- 4 Motor Voltage

To find starting amperage:

Step 1: Find code and use table to find kVA/HP. If code is not listed, multiply running amperage by six to find starting amperage.

Step 2: Find Motor HP and Volts.

Step 3: Determine starting amperage (see example).

Welding generator amperage output must be at least twice the motor's running amperage.

Single-Phase Induction Motor Starting Requirements

Motor Start Code	G	H	J	K	L	M	N	P
KVA/HP	6.3	7.1	8.0	9.0	10.0	11.2	12.5	14.0

$$\frac{\text{kVA/HP} \times \text{HP} \times 1000}{\text{VOLTS}} = \text{STARTING AMPERAGE}$$

EXAMPLE: Calculate the starting amperage required for a 230 V, 1/4 HP motor with a motor start code of M.

Volts = 230 HP = 1/4 Using Table, Code M results in kVA/HP = 11.2

$$\frac{11.2 \times 1/4 \times 1000}{230} = 12.2 \text{ A} \quad \text{Starting the motor requires 12.2 amperes.}$$

S-0624

10-9. How Much Power Can Generator Supply?

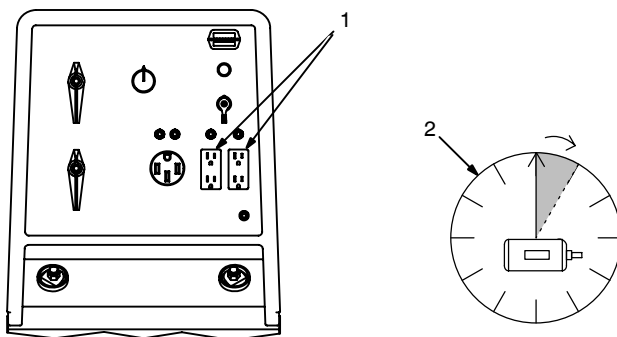

- 1 Limit Load To 90% Of Generator Output

Always start non-resistive (motor) loads in order from largest to smallest, and add resistive loads last.

- 2 5 Second Rule

If motor does not start within 5 seconds, turn off power to prevent motor damage. Motor requires more power than generator can supply.

Ref. ST-800 396-A / S-0625

10-10. Typical Connections To Supply Standby Power



☞ *Customer-supplied equipment is required if generator is to supply standby power during emergencies or power outages.*

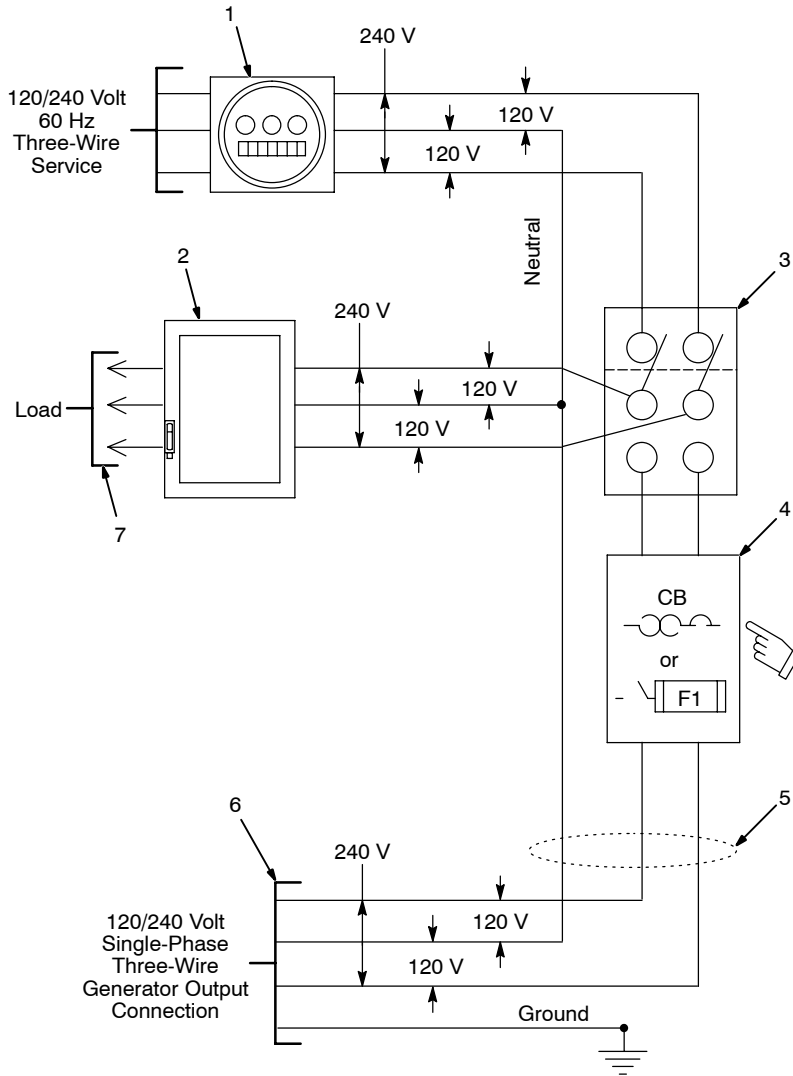

- 1 Power Company Service Meter
- 2 Main and Branch Overcurrent Protection
- 3 Double-Pole, Double-Throw Transfer Switch

Obtain and install correct switch. Switch rating must be same as or greater than the branch overcurrent protection.

- 4 Circuit Breakers or Fused Disconnect Switch

Obtain and install correct circuit breakers or switch.

- 5 Extension Cord

Select as shown in Section 10-11.

- 6 Generator Connections

Connect terminals or plug of adequate amperage capacity to cord. Follow all applicable codes and safety practices.

Turn off or unplug all equipment connected to generator before starting or stopping engine. When starting or stopping, the engine has low speed which causes low voltage and frequency.

- 7 Load Connections

Item 4 is not necessary if circuit protection is already present in welding generator auxiliary power output circuit.

10-11. Selecting Extension Cord (Use Shortest Cord Possible)



Cord Lengths for 120 Volt Loads

▲ If unit does not have GFCI receptacles, use GFCI-protected extension cord.

Current (Amperes)	Load (Watts)	Maximum Allowable Cord Length in ft (m) for Conductor Size (AWG)*					
		4	6	8	10	12	14
5	600			350 (106)	225 (68)	137 (42)	100 (30)
7	840		400 (122)	250 (76)	150 (46)	100 (30)	62 (19)
10	1200	400 (122)	275 (84)	175 (53)	112 (34)	62 (19)	50 (15)
15	1800	300 (91)	175 (53)	112 (34)	75 (23)	37 (11)	30 (9)
20	2400	225 (68)	137 (42)	87 (26)	50 (15)	30 (9)	
25	3000	175 (53)	112 (34)	62 (19)	37 (11)		
30	3600	150 (46)	87 (26)	50 (15)	37 (11)		
35	4200	125 (38)	75 (23)	50 (15)			
40	4800	112 (34)	62 (19)	37 (11)			
45	5400	100 (30)	62 (19)				
50	6000	87 (26)	50 (15)				

*Conductor size is based on maximum 2% voltage drop

Cord Lengths for 240 Volt Loads

▲ If unit does not have GFCI receptacles, use GFCI-protected extension cord.

Current (Amperes)	Load (Watts)	Maximum Allowable Cord Length in ft (m) for Conductor Size (AWG)*					
		4	6	8	10	12	14
5	1200			700 (213)	450 (137)	225 (68)	200 (61)
7	1680		800 (244)	500 (152)	300 (91)	200 (61)	125 (38)
10	2400	800 (244)	550 (168)	350 (107)	225 (69)	125 (38)	100 (31)
15	3600	600 (183)	350 (107)	225 (69)	150 (46)	75 (23)	60 (18)
20	4800	450 (137)	275 (84)	175 (53)	100 (31)	60 (18)	
25	6000	350 (107)	225 (69)	125 (38)	75 (23)		
30	7000	300 (91)	175 (53)	100 (31)	75 (23)		
35	8400	250 (76)	150 (46)	100 (31)			
40	9600	225 (69)	125 (38)	75 (23)			
45	10,800	200 (61)	125 (38)				
50	12,000	175 (53)	100 (31)				

*Conductor size is based on maximum 2% voltage drop

SECTION 11 – PARTS LIST

 Hardware is common and not available unless listed.

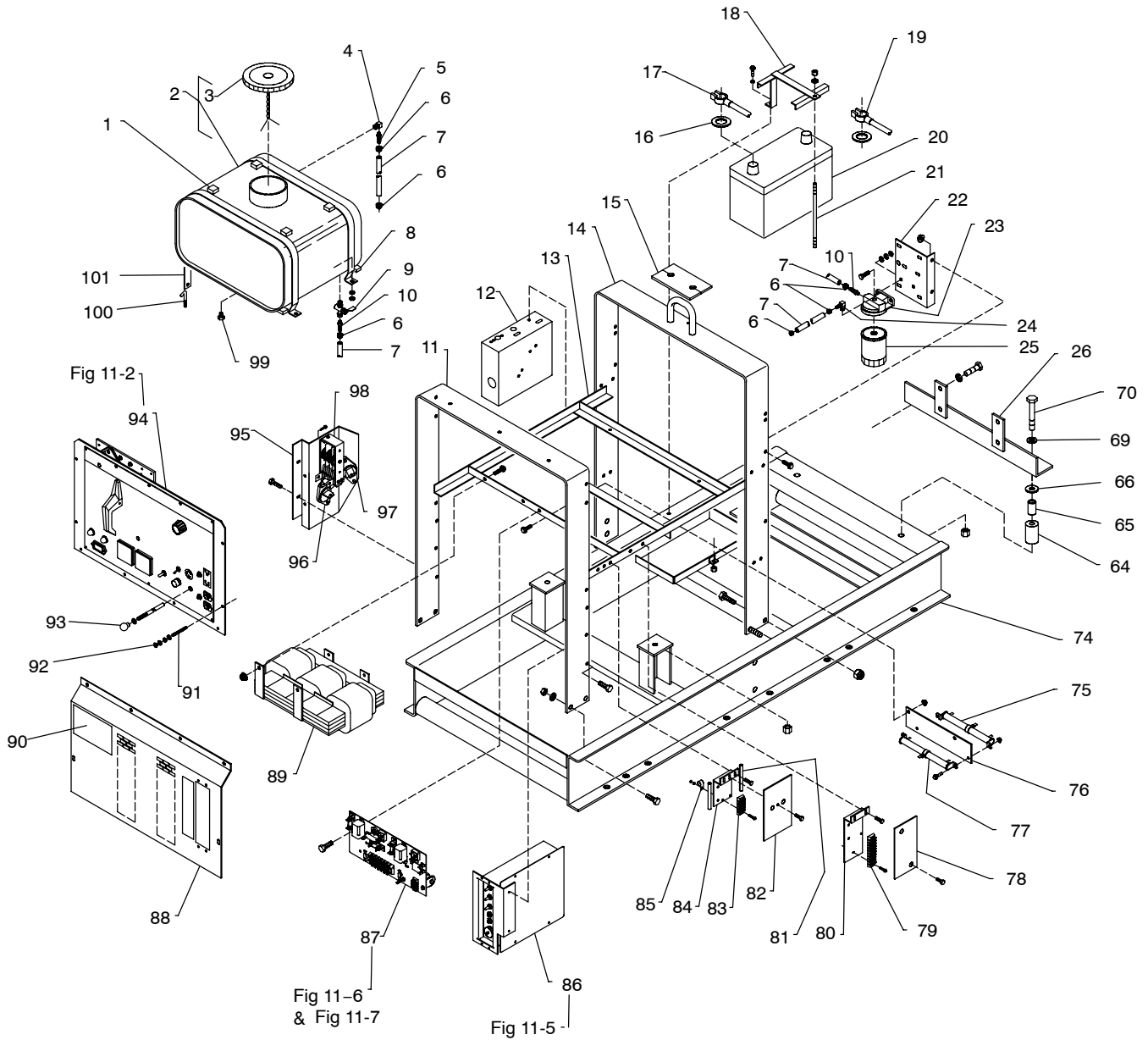

Figure 11-1. Main Assembly

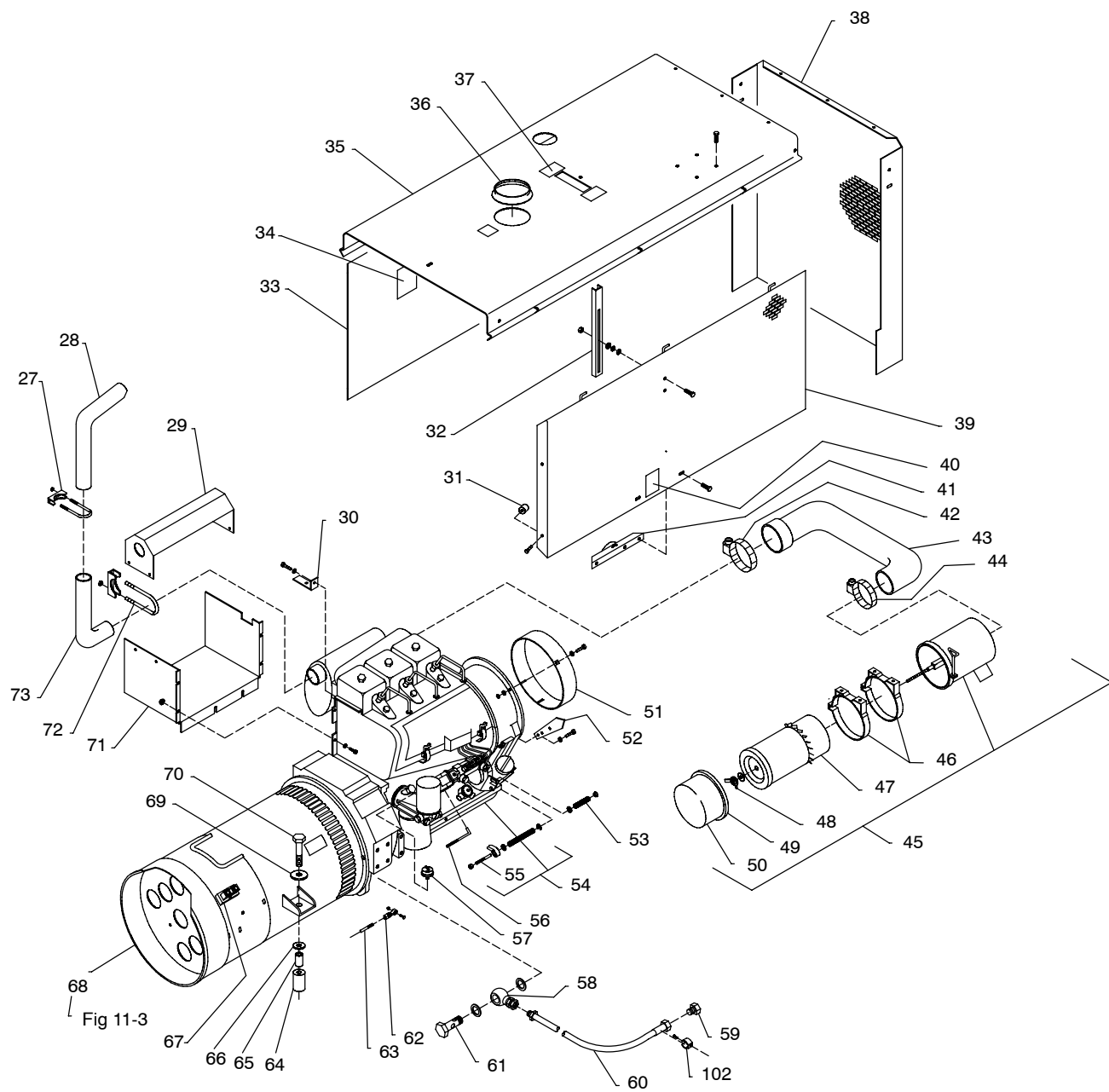

Fig 11-3

Item No.	Dia. Mkgs.	Part No.	Description	Quantity
Figure 11-1. Main Assembly				
1		134 771	PLUG, protective .640sq	4
2		184 675	TANK, fuel 23gal (consisting of)	1
3		182 022	CAP, fuel large	1
4		020 185	FITTING, pipe brs elb st 1/8NPT	1
5		053 525	FITTING, brs barbed M 5/16tbg x 1/8NPT	1
6		172 071	CLAMP, hose .520-.605clp dia slfittng	6
7		134 835	HOSE, SAE .312 ID x .560 OD (order by ft)	6ft
8		097 507	STRIP, rbr adh back .125 x 1.000 x 20.500	2
9		010 314	VALVE, shut-off fuel	1
10		039 599	FITTING, brs barbed M 5/16tbg x 1/4NPT	2
11		+048 227	UPRIGHT, base front	1
12		◆134 903	FUSE BOX	1
		+◆134 902	COVER, fuse box	1
		◆179 637	LABEL, warning auxiliary power	1
		◆026 947	STAND-OFF, insulator	1
		◆149 541	HOLDER, fuse crtg 60A 250V	1
		*◆089 585	FUSE, crtg 35A 250V	3
		◆604 102	CONNECTOR, clamp cable 1.000	2
		◆048 489	CLAMP, nyl 1.000dia	1
13		170 689	FRAME, mtg reactor	1
14		170 617	UPRIGHT, base center	1
15		017 479	SEAL, weather lift eye	1
16		108 081	TERMINAL PROTECTOR, battery post mtg	2
17		182 276	CABLE, bat pos	1
18		118 644	HOLD DOWN, battery	1
19		032 453	CABLE, bat neg	1
20	BAT	012 724	BATTERY, 12V 95A	1
21		010 460	STUD, stl .312-18 x 10.000	1
22		083 859	BRACKET, mtg fuel filter	1
23		083 553	BASE, filter fuel w/adapter	1
24		145 282	FITTING, hose brs barbed elb M 5/16tbg x 1/4NPT	1
25		062 342	SEPARATOR, fuel filter & water	1
26		116 707	SUPPORT, front engine	1
27		010 875	CLAMP, muffler 2.000dia U	1
28		105 734	PIPE, muffler ext elb	1
29		176 232	BAFFLE, air muffler exhaust	1
30		048 216	BRACKET, mtg breather	1
31		087 341	BUMPER, door 1.000 OD x .750 high	4
32		004 130	BRACKET, support door	2
33		+091 160	DOOR, LH side	1
		168 385	LABEL, warning battery explosion can blind	1
34		181 642	LABEL, diesel engine maintenance	1
35		+105 909	COVER, top	1
36		035 968	WASHER, flat rbr 3.625 ID x 5.875 OD x .062thk	1
		195 869	CABLE TIE, 0-17.500 weather resistant	1
37		108 487	LABEL, warning falling equipment etc	2
38		048 206	PANEL, end engine	1
39		+106 411	DOOR, RH side	1
		089 343	RIVET, nyl .250dia x 1.000 lg	6
40		158 610	LABEL, warning electric shock and moving parts	2
41		087 336	LATCH, door	2
42		023 313	CLAMP, hose 3.250-3.000clp dia slfittng	1
43		177 323	HOSE, air cleaner	1
44		010 863	CLAMP, hose 2.062-3.000clp dia slfittng	1
		165 785	HOSE, air cleaner 2.500 ID	1
45		045 657	AIR CLEANER, intake (consisting of)	1
46		021 115	BAND, mtg air cleaner	2
47		*020 319	ELEMENT	1
48		021 117	WING NUT ASSEMBLY	1
49		021 114	CLAMP ASSEMBLY	1
50		021 116	CAP, dust	1
		004 115	BAFFLE, dust cap	1
51		048 213	BAFFLE, air intake	1
52			LEVER, trip shutdown (included w/engine - see engine parts list)	1

Item No.	Dia. Mkgs.	Part No.	Description	Quantity
Figure 11-1. Main Assembly (Continued)				
53			SPRING, (included w/engine – see engine parts list)	1
54		181 634	ENGINE, diesel electric (consisting of)	1
55		087 371	ROD, shutdown	1
56		070 661	ROD, speed control	1
		604 393	NUT, speed push-on type .187	1
57	S5	151 969	SWITCH, pressure oil 4psi NO	1
58		◆047 361	FITTING, banjo	1
59		◆089 351	FITTING, pipe brs plug hexhd 1/2NPT	1
60		◆008 114	HOSE, oil w/fittings 17.500 lg	1
61		◆047 234	BOLT, banjo	1
		◆047 235	WASHER, oil seal copper	2
62		127 994	BALL JOINT, .250-28	1
63		162 740	STUD, stl .250-28 x 45.000	1
		032 878	CLAMP, stl cush .500dia x .406mtg hole (used on wiring harness)	1
64		083 476	TUBING, nprn .875 ID x 2.500 OD x 2.000	2
65		071 730	TUBING, stl .875 OD x 12ga wall x 2.375	4
66		071 890	RETAINER, mount engine/generator	4
67	SHUNT	030 084	SHUNT, meter 500MV 600A	1
68		Fig 11-3	GENERATOR	1
69		071 731	WASHER, flat stl .656 ID x 2.250 OD x .187thk	4
70		601 945	SCREW, cap stl hexhd .625-18 x 4.000	4
71		176 236	BAFFLE, air outlet	1
72			CLAMP, muffler (included w/engine – see engine parts list)	1
73		105 733	PIPE, muffler extension elb	1
74		165 739	BASE	1
75	R2	030 060	RESISTOR, WW adj 375W 20 ohm (CC model)	1
76		170 681	STRIP, mtg resistor	1
77	R3	128 862	RESISTOR, WW adj 375W 50 ohm (CC model)	1
78		◆186 008	INSULATION, terminal strip	1
79	2T	◆038 601	BLOCK, term 30A 9P	1
80		◆184 499	BRACKET, mtg terminal strip	1
	PLG21	◆168 071	CONNECTOR & SOCKETS	1
81		603 107	HOSE, nprn slit bk .156 ID x .343 OD (order by ft)	1ft
82		053 967	INSULATION, rectifier	1
83	TE1/TE4	038 621	BLOCK, term 30A 4P	1
		038 620	LINK, jumper	2
84		081 499	BRACKET, mtg	1
85		010 146	CLAMP, nyl .625clp dia	1
86		Fig 11-5	CV-3 CONTROL BOX	1
87		Fig 11-6	PANEL, mtg components (CC/CV model)	1
87		Fig 11-7	PANEL, mtg components (CC model)	1
88		+182 171	PANEL, front lower (CC model)	1
88		+◆185 826	PANEL, front lower (CC/CV model)	1
89	Z1	169 424	REACTOR	1
90		134 792	LABEL, warning general precautionary	1
91		083 030	STUD, brs .250-20 x 1.750 grounding	1
92		601 836	NUT, brs hex .250-20 jam hvy grounding	3
93		019 603	KNOB, ball	1
94		Fig 11-2	PANEL, front w/components	1
95		108 127	BRACKET, mtg terminal pwr output	1
95		◆088 951	BRACKET, mtg components	1
96	Pos	039 047	TERMINAL, pwr output red	1
97	Neg	039 046	TERMINAL, pwr output black	1
98		◆091 067	SWITCH, polarity	1
		◆059 773	HANDLE, switch	1
99		605 288	FITTING, pipe galv plug sq hd .250NPT	1
100		070 010	BOLT, J stl .250-20 x 2.750	2
101		088 696	STRAP, hold down fuel tank	2
		045 161	KIT, label	1
102		◆192 197	BRACKET, mounting	1

+When ordering a component originally displaying a precautionary label, the label should also be ordered.

◆OPTIONAL *Recommended Spare Parts.

To maintain the factory original performance of your equipment, use only Manufacturer's Suggested Replacement Parts. Model and serial number required when ordering parts from your local distributor.

☞ Hardware is common and not available unless listed.

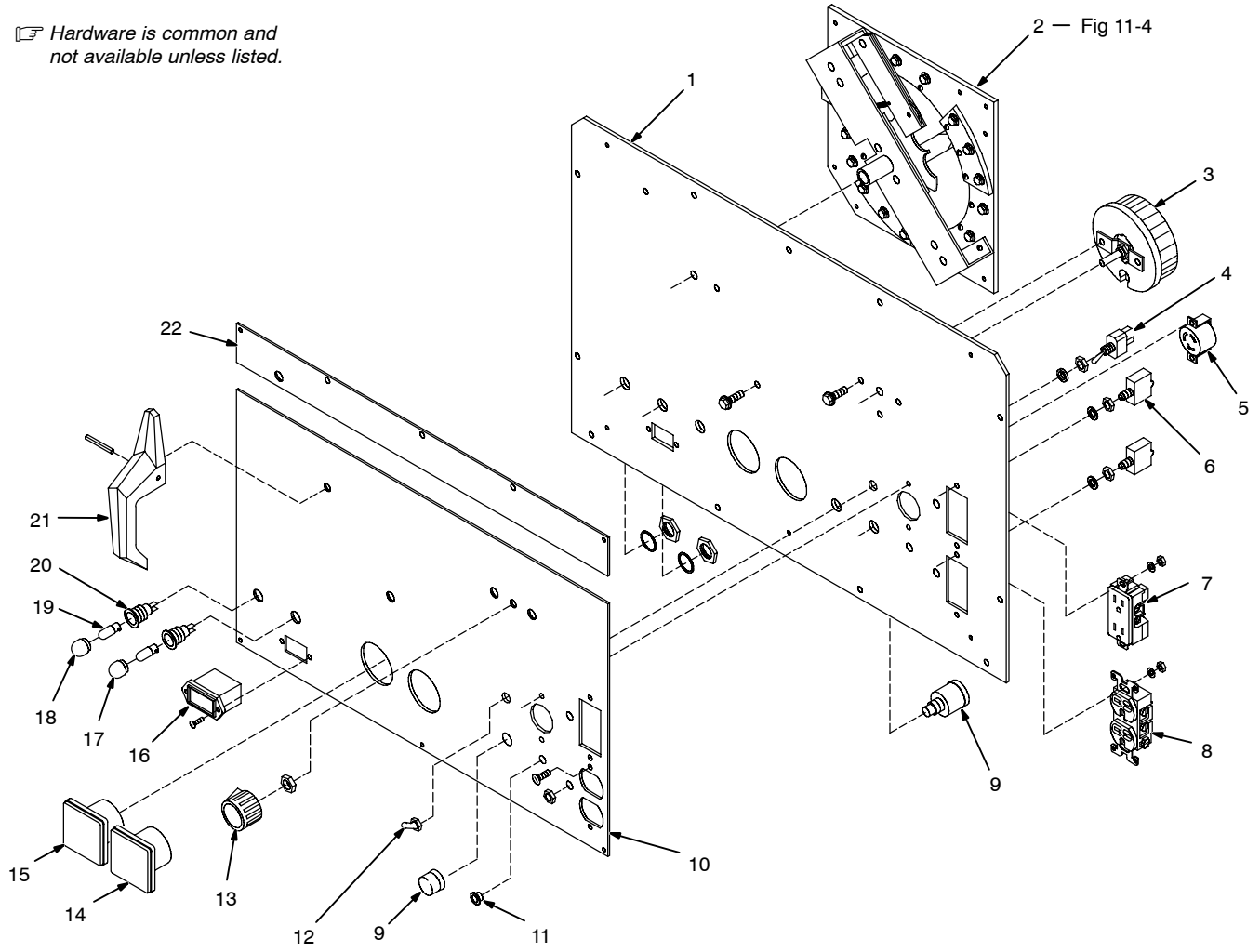

ST-048 457-N

Figure 11-2. Panel, Front w/Components (CC Model Illustrated)

Item No.	Dia. Mkgs.	Part No.	Description	Quantity
Figure 11-2. Panel, Front w/Components (Fig 11-1 Item 94)				
1		154 292	PANEL, front upper	1
2	S3	171 878	SWITCH, range (Fig 11-4)	1
3	R1	605 960	RHEOSTAT, WW 300W 34 ohm (CC model)	1
3	R1	◆072 462	POTENTIOMETER, C std sft 1/T 2W 1000 ohm (CV/CC model)	1
4		011 609	SWITCH, tgl SPDT 15A 125VAC (CC model)	1
5		032 897	RECEPTACLE, twlk grd 2P3W 15A 125V (CC model)	1
		073 690	PLUG, str grd armd 2P3W 15A Arrow Hart 5965V	
6	CB1,2	139 266	CIRCUIT BREAKER, man reset 1P 15A 250VAC	2
7	GFCI 1	◆168 068	RECEPTACLE, str dx grd 2P3W 15A 125V	1
7	RC2	170 901	RECEPTACLE, str dx grd 2P3W 125V (top) (CC model)	1
8	RC1	604 103	RECEPTACLE, str dx grd 2P3W 15A 250V (bottom)	1
		170 493	PLATE, ident receptacle	1
		025 234	PLUG, str grd 2P3W 15A 250V Arrow Hart 5666V	
9	PB1	046 433	SWITCH, PB MC NO w/black cap	1
10		180 904	PLATE, ident control rating (CC model)	1
10		◆185 763	PLATE, ident control rating (CC/CV model)	1
11		088 731	BUSHING, snap-in nyl .375 ID x .500mtg hole	1
12		021 385	BOOT, toggle switch lever	1
13		148 723	KNOB, pointer	1
14		◆046 652	METER, amp DC 50MV 0-600	1
15		◆046 654	METER, volt DC 0-100	1
		◆003 645	BUS BAR, shunt/sec	2
		◆145 626	BRACKET, mtg shunt	1
16	HM	145 247	METER, hour 10-24VDC	1
17		082 790	LENS, light green	1
18		082 789	LENS, light red	1
19	PL1,2	*048 155	BULB, incand flg base 12V	2
20		082 788	HOLDER, indicator light	2
21		019 754	HANDLE, switch range	1
22			NAMEPLATE, (order by model and serial number)	1

◆OPTIONAL

*Recommended Spare Parts.

To maintain the factory original performance of your equipment, use only Manufacturer's Suggested Replacement Parts. Model and serial number required when ordering parts from your local distributor.

Hardware is common and not available unless listed.

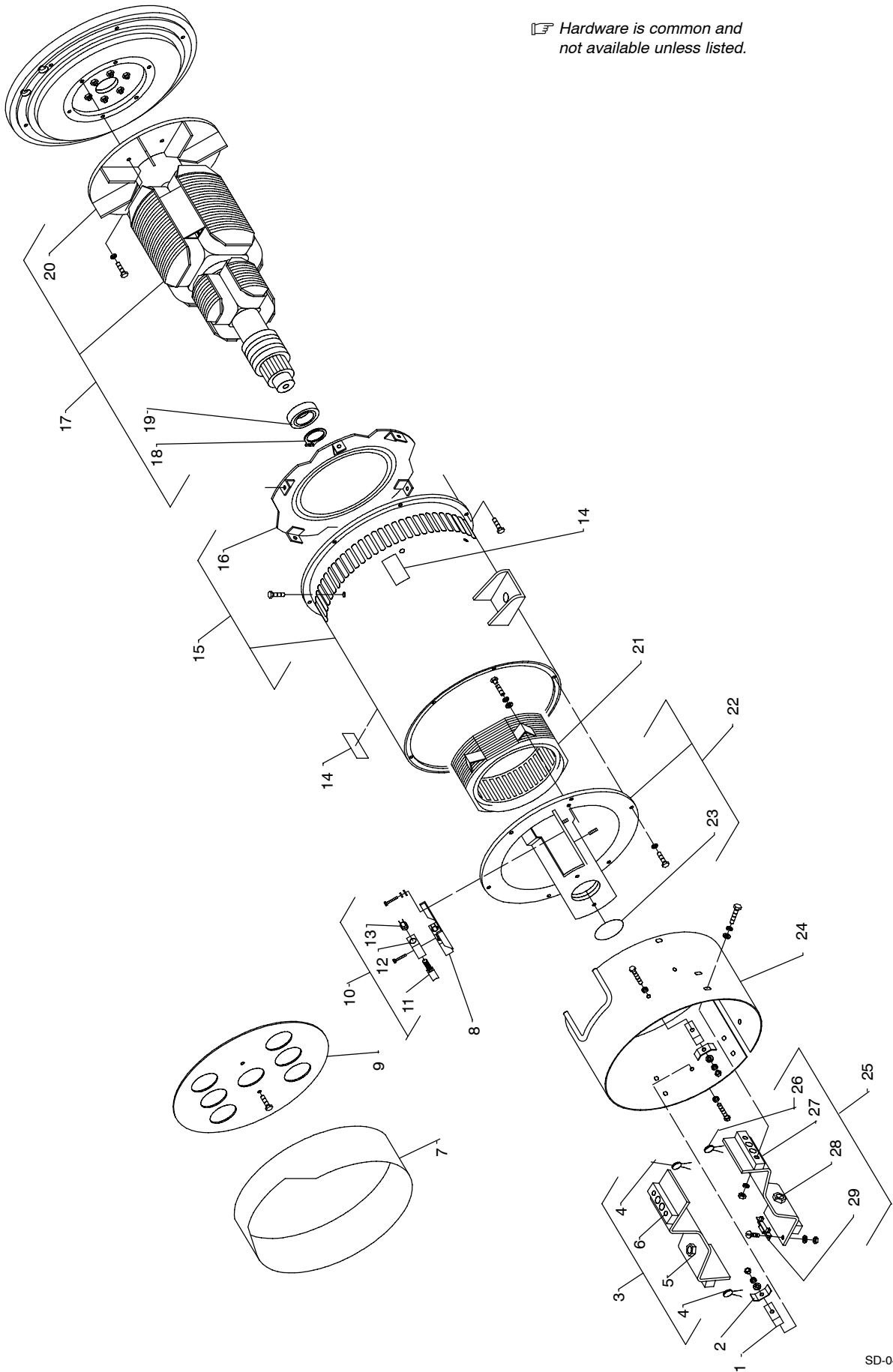

Figure 11-3. Generator

SD-048 456-E

Item No.	Dia. Mkgs.	Part No.	Description	Quantity
Figure 11-3. Generator (Fig 11-1 Item 68)				
1		106 426	INSULATOR	4
2		106 440	BUS BAR, rectifier	2
3	SR3	106 427	DIODE ASSEMBLY, reverse polarity (consisting of)	1
4	C4,6	048 420	CAPACITOR, rectifier	2
	C2	106 641	CAPACITOR	1
5	D2,4,6	037 957	DIODE, rect 275A 300V RP	3
6		106 425	INSULATOR	2
7		182 170	BAFFLE, air rectifier	1
8		173 066	BRACKET, mtg brushholder	1
9		048 202	BAFFLE, air diodes	1
10		018 614	BRUSH SET, (consisting of)	3
11		*151 299	BRUSH, contact	1
12		600 270	HOLDER, brush	1
13		152 044	CAP, brushholder	1
14		013 367	LABEL, warning moving parts can cause serious injury	2
15		+169 423	STATOR, gen (consisting of)	1
15		+♦170 496	STATOR, gen (consisting of)	1
16		039 207	BAFFLE, air gen	1
17		083 751	ROTOR, gen (consisting of)	1
18		024 617	RING, retaining external	1
19		053 390	BEARING, ball	1
20		083 748	FAN, rotor	1
21		044 374	STATOR, excitor (CC model)	1
21		♦180 684	STATOR, excitor (CC/CV model)	1
22		173 068	ENDBELL, gen (consisting of)	1
23		143 220	O-RING, 2.859 ID x .139CS	1
24		106 424	BARREL, rectifier	1
25	SR3	106 430	DIODE ASSEMBLY, (consisting of)	1
26	C5,7	048 420	CAPACITOR, rectifier	2
	C3	106 641	CAPACITOR	1
27		106 425	INSULATOR	1
28	D1,3,5	037 956	DIODE, rect 275A 300V SP	3
29	VR1,R4	046 819	SUPPRESSOR	1

*Recommended Spare Parts.

+When ordering a component originally displaying a precautionary label, the label should also be ordered.

♦Part of 042 890 Optional 10/7.5kVA 240/120V Auxiliary Power.

To maintain the factory original performance of your equipment, use only Manufacturer's Suggested Replacement Parts. Model and serial number required when ordering parts from your local distributor.

Item No.	Dia. Mkgs.	Part No.	Description	Quantity
171 878 Figure 11-4. Switch, Range (Fig 11-2 Item 2)				
.. 1		114 235 ..	BRACKET, mtg switch range (consisting of)	1
.. 2		010 671	SPRING, ext .312 OD x .042 wire x 1.875	1
.. 3		017 428 ..	LOCATOR, quadrant switch	1
.. 4 ... S10		172 245 ..	SWITCH, micro	1
.. 5		170 677 ..	BOOT, switch lim plunger seal	1
.. 6		171 854 ..	CONTACT BOARD, (consisting of)	1
.. 7		172 701	CONTACT, movable switch (consisting of)	3
.. 8		011 025	SPRING, pressure	1
.. 9		011 010	CONTACT, switch copper	2
.. 10		011 009	CONTACT, switch bronze	2
.. 11		171 856	SPACER, contact .250thk	1
.. 12		011 007	SPRING, pressure	1
.. 13		011 018	CONTACT, stationary	9
.. 14		172 702	CONTACT, stationary switch (consisting of)	6
.. 15		011 018	CONTACT, stationary	2
.. 16		171 856	SPACER, contact .250thk	1
.. 17		011 095	CONTACT BOARD, stationary switch	2
.. 18		011 019	CONTACT BOARD, movable switch	2
.. 19		011 012	SHIM, guide contact board	6
.. 20		011 013	GUIDE, contact board movable switch	3

 Hardware is common and not available unless listed.

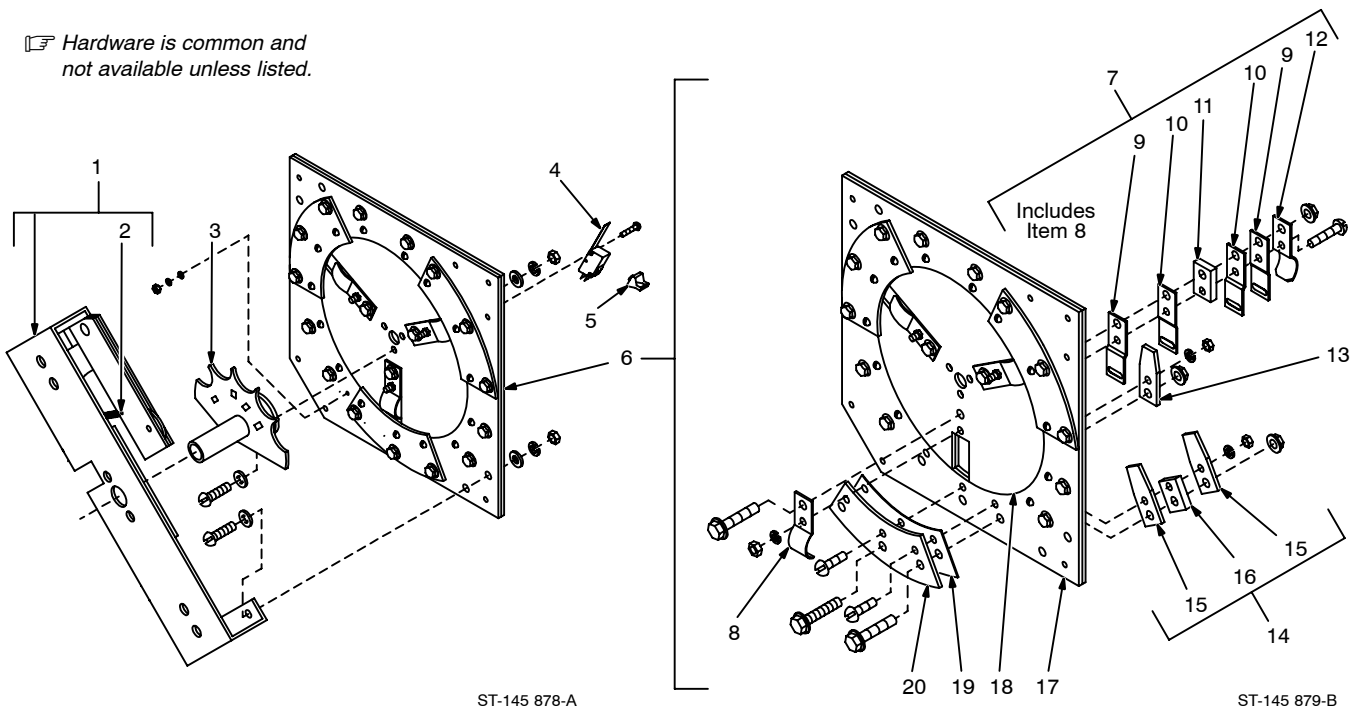



Figure 11-4. Switch, Range

To maintain the factory original performance of your equipment, use only Manufacturer's Suggested Replacement Parts. Model and serial number required when ordering parts from your local distributor.

Item No.	Dia. Mkgs.	Part No.	Description	Quantity
----------	------------	----------	-------------	----------

Figure 11-5. Control Box CC/CV (Figure 11-1 Item 86) (Optional)

1		605 321	NUT, .468-32 brs blk	3
2	S6	011 611	SWITCH, tgl DPDT 15A 125V	1
3	S8,9	011 609	SWITCH, tgl SPDT 15A 125V	2
4		601 836	NUT, .250-20	3
5		010 915	WASHER, flat	3
6		083 030	STUD, brs .250-20 x 1.750	1
7		185 778	CV CONTROL BOX	1
8	RC20	147 663	CONNECTOR & SOCKETS	1
9	RC21	168 071	CONNECTOR & SOCKETS	1
10	RC22	158 466	CONNECTOR & SOCKETS	1
11	SR2	097 353	DIODE/SCR BRIDGE	1
12	PC1	185 746	CIRCUIT CARD ASSEMBLY, field	1
13	RC1	114 064	CONNECTOR, rect univ 84 15 pin	1
14	PLG1	135 275	CONNECTOR & PINS	1
15		134 201	STAND-OFF, support PC card	11
16	PC2	185 747	CIRCUIT CARD ASSEMBLY, voltage	1
17	RC1	115 092	CONNECTOR & SOCKETS	1
18	PC3	150 415	CIRCUIT CARD ASSEMBLY, CONNECTOR	1
19		185 761	COVER, CV control box	1
20	PLG3-5	165 668	CONNECTOR & PINS	3
21	CB3,4	083 432	CIRCUIT BREAKER, man reset 1P 10A 250VAC	2
22	RC3	143 976	CONNECTOR & SOCKETS	1
23		039 885	CONNECTOR, circ MS protective	1
24		147 195	NUT, .375-27 nyl	2
25		021 385	BOOT, tgl switch	3

 Hardware is common and not available unless listed.

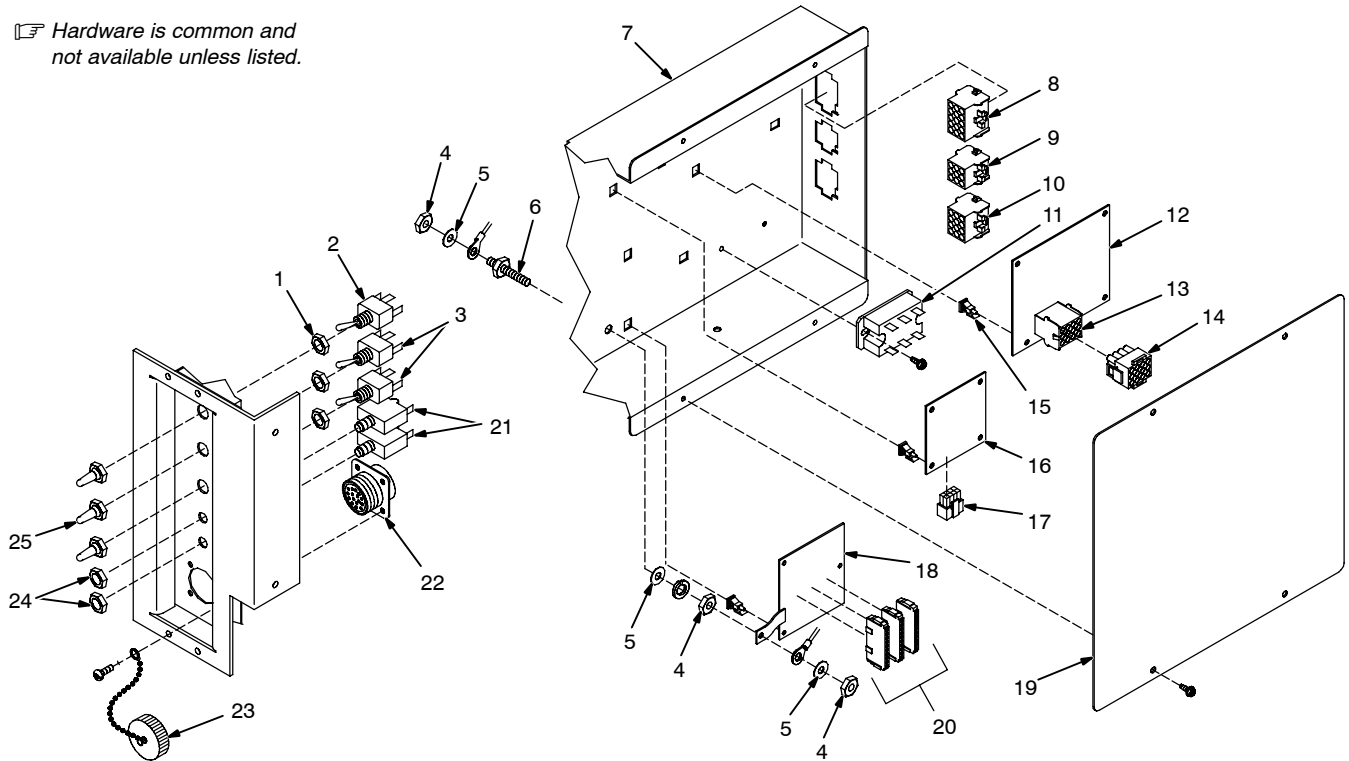

ST-801 850

Figure 11-5. Control Box CC/CV (Optional)

To maintain the factory original performance of your equipment, use only Manufacturer's Suggested Replacement Parts. Model and serial number required when ordering parts from your local distributor.

Item No.	Dia. Mkgs.	Part No.	Description	Quantity
----------	------------	----------	-------------	----------

**Figure 11-6. Panel, Mtg Components (CC/CV Model)
(Figure 11-1 Item 87)**

.. 1	.. R2	.. 185 748	.. RESISTOR BOARD	.. 1
.. 2	.. SR1,4	.. 035 704	.. RECTIFIER, integ 40A 800V	.. 2
.. 3	.. D8	.. 192 307	.. KIT, diode w/washers	.. 1
.. 4	.. R3	.. 128 862	.. RESISTOR, WW adj 375W 50 ohm w/mtg bkt	.. 1
.. 5 601 836	.. NUT, brs 250-20	.. 2
.. 6 134 201	.. STAND-OFF SUPPORT, PC card	.. 3
.. 7 185 187	.. PANEL, mtg components	.. 1
.. 8	.. 3T	.. 185 189	.. BLOCK, terminal 15A 3P	.. 1
.. 9 083 030	.. STUD, brs .250-20 x 1.750 hex collar	.. 1
.. 10 010 913	.. WASHER, flat brs	.. 1
.. 11	.. 1T	.. 038 639	.. BLOCK, terminal 30A 6P	.. 1
.. 12 164 617	.. CLIP, wiring	.. 2
.. 13	.. D1	.. 189 701	.. DIODE/CAPACITOR BOARD	.. 1
.. 14	.. C8	.. 170 674	.. CAPACITOR BOARD	.. 1
.. 15	.. R6	.. 030 844	.. RESISTOR, WW fxd 25W 25 ohm	.. 1
.. 16 605 741	.. CLIP, mtg resistor	.. 2
.. 17	.. CR1,2	.. 044 588	.. RELAY, encl 12VDC 3PDT	.. 2

 Hardware is common and not available unless listed.

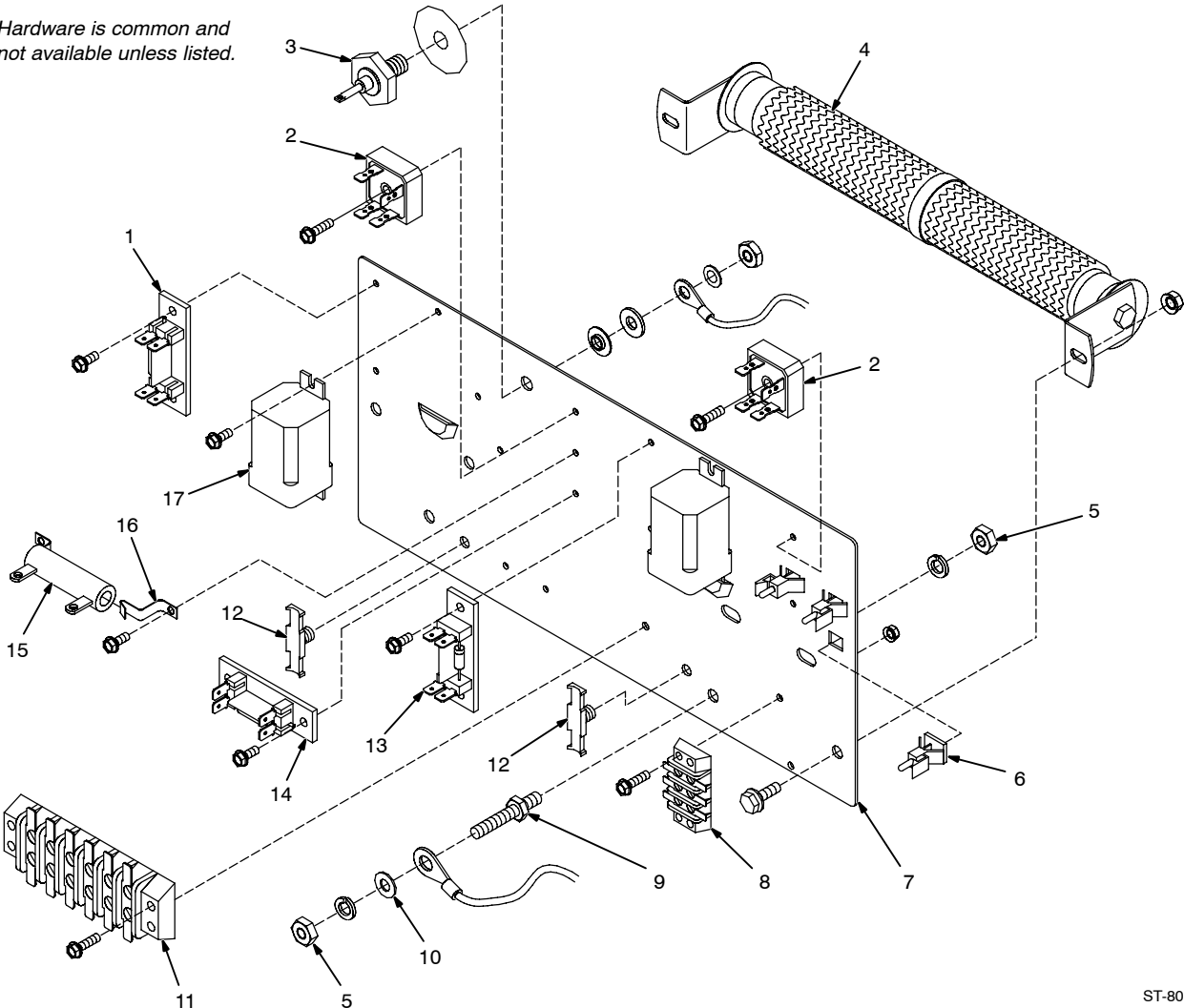

ST-801 851

Figure 11-6. Panel, Mtg Components (CC/CV Model)

To maintain the factory original performance of your equipment, use only Manufacturer's Suggested Replacement Parts. Model and serial number required when ordering parts from your local distributor.

Item No.	Dia. Mkgs.	Part No.	Description	Quantity
----------	------------	----------	-------------	----------

**Figure 11-7. Panel, Mtg Components (CC Model)
(Figure 11-1 Item 87)**

.. 1	170 672	.. PANEL, mtg components	1
.. 2 ... R6 ...	030 844	.. RESISTOR, WW fxd 25W 250 ohm	1
.. 3	605 741	.. CLIP, mtg resistor	2
.. 4 ... R5 ...	128 862	.. RESISTOR, WW adj 375W	1
.. 5 . SR1,2,4	035 704	.. RECTIFIER, integ 40A 800V	3
.. 6 ... 2T ...	038 621	.. TERMINAL BLOCK, 30A 4P	1
.. 7 .. CR2 ..	044 588	.. RELAY, encl 12VDC 3PDT	1
.. 8 ... D1 ...	189 701	.. DIODE/CAPACITOR BOARD	1
.. 9 ... D8 ...	192 307	.. KIT, diode w/washers	1
.. 10 .. C8 ...	170 674	.. CAPACITOR BOARD	1

 Hardware is common and not available unless listed.

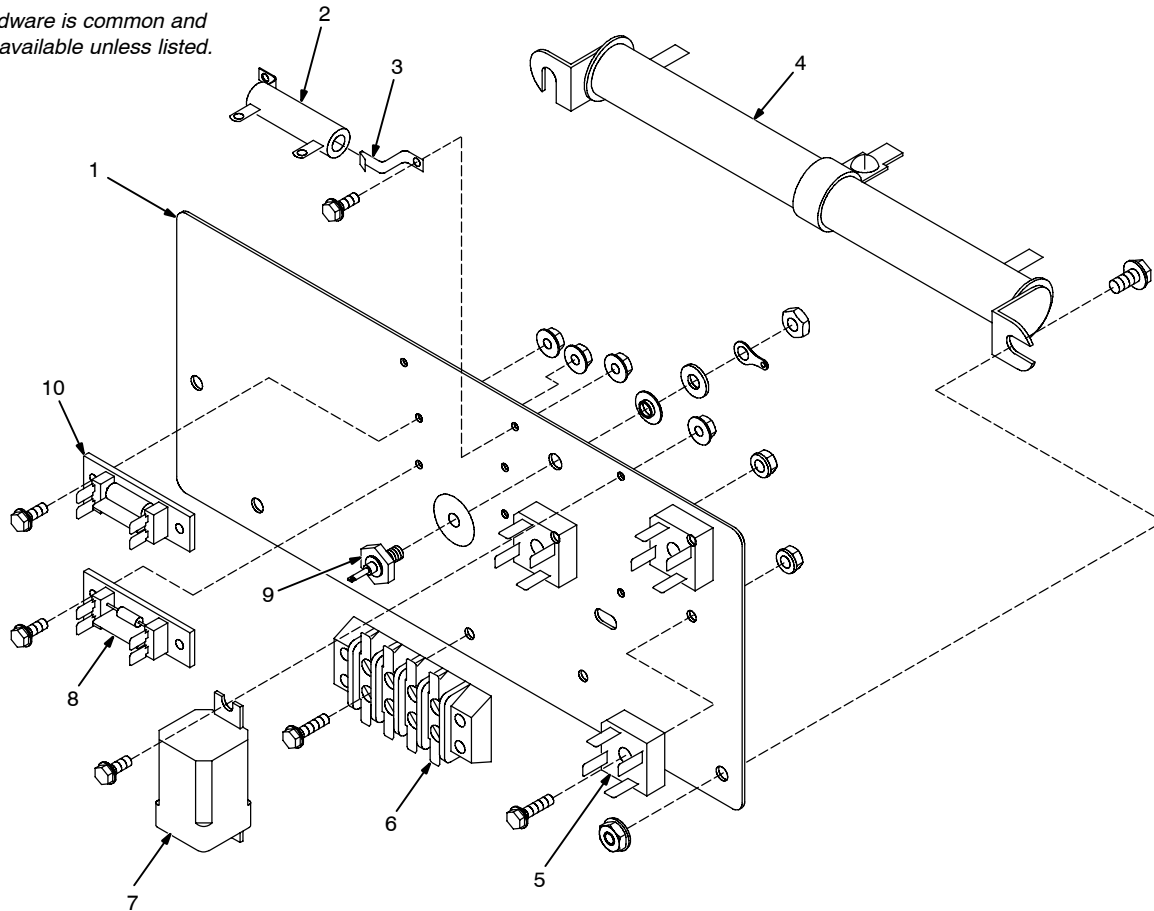

ST-801 852

Figure 11-7. Panel, Mtg Components (CC Model)

To maintain the factory original performance of your equipment, use only Manufacturer's Suggested Replacement Parts. Model and serial number required when ordering parts from your local distributor.

TRUE BLUE® WARRANTY

Effective January 1, 1999
(Equipment with a serial number preface of "KK" or newer)

This limited warranty supersedes all previous Miller warranties and is exclusive with no other guarantees or warranties expressed or implied.

LIMITED WARRANTY – Subject to the terms and conditions below, Miller Electric Mfg. Co., Appleton, Wisconsin, warrants to its original retail purchaser that new Miller equipment sold after the effective date of this limited warranty is free of defects in material and workmanship at the time it is shipped by Miller. THIS WARRANTY IS EXPRESSLY IN LIEU OF ALL OTHER WARRANTIES, EXPRESS OR IMPLIED, INCLUDING THE WARRANTIES OF MERCHANTABILITY AND FITNESS.

Within the warranty periods listed below, Miller will repair or replace any warranted parts or components that fail due to such defects in material or workmanship. Miller must be notified in writing within thirty (30) days of such defect or failure, at which time Miller will provide instructions on the warranty claim procedures to be followed.

Miller shall honor warranty claims on warranted equipment listed below in the event of such a failure within the warranty time periods. All warranty time periods start on the date that the equipment was delivered to the original retail purchaser, or one year after the equipment is sent to a North American distributor or eighteen months after the equipment is sent to an International distributor.

1. 5 Years Parts – 3 Years Labor
 - * Original main power rectifiers
 - * Inverters (input and output rectifiers only)
2. 3 Years — Parts and Labor
 - * Transformer/Rectifier Power Sources
 - * Plasma Arc Cutting Power Sources
 - * Semi-Automatic and Automatic Wire Feeders
 - * Inverter Power Supplies
 - * Intellitig
 - * Engine Driven Welding Generators
(NOTE: Engines are warranted separately by the engine manufacturer.)
3. 1 Year — Parts and Labor
 - * Motor Driven Guns (w/exception of Spoolmate 185)
 - * Process Controllers
 - * Positioners and Controllers
 - * Automatic Motion Devices
 - * Robots
 - * RFCS Foot Controls
 - * IHPS Power Sources
 - * Water Coolant Systems
 - * HF Units
 - * Grids
 - * Maxstar 140
 - * Spot Welders
 - * Load Banks
 - * SDX Transformers
 - * Miller Cyclomatic Equipment
 - * Running Gear/Trailers
 - * Plasma Cutting Torches (except APT, ZIPCUT & PLAZCUT Models)
 - * Field Options
(NOTE: Field options are covered under True Blue® for the remaining warranty period of the product they are installed in, or for a minimum of one year — whichever is greater.)
4. 6 Months — Batteries
5. 90 Days — Parts
 - * MIG Guns/TIG Torches

- * APT, ZIPCUT & PLAZCUT Model Plasma Cutting Torches
- * Remote Controls
- * Accessory Kits
- * Replacement Parts (No labor)
- * Spoolmate 185

Miller's True Blue® Limited Warranty shall not apply to:

1. Items furnished by Miller, but manufactured by others, such as engines or trade accessories. These items are covered by the manufacturer's warranty, if any.
2. Consumable components; such as contact tips, cutting nozzles, contactors, brushes, slip rings, relays or parts that fail due to normal wear.
3. Equipment that has been modified by any party other than Miller, or equipment that has been improperly installed, improperly operated or misused based upon industry standards, or equipment which has not had reasonable and necessary maintenance, or equipment which has been used for operation outside of the specifications for the equipment.

MILLER PRODUCTS ARE INTENDED FOR PURCHASE AND USE BY COMMERCIAL/INDUSTRIAL USERS AND PERSONS TRAINED AND EXPERIENCED IN THE USE AND MAINTENANCE OF WELDING EQUIPMENT.

In the event of a warranty claim covered by this warranty, the exclusive remedies shall be, at Miller's option: (1) repair; or (2) replacement; or, where authorized in writing by Miller in appropriate cases, (3) the reasonable cost of repair or replacement at an authorized Miller service station; or (4) payment of or credit for the purchase price (less reasonable depreciation based upon actual use) upon return of the goods at customer's risk and expense. Miller's option of repair or replacement will be F.O.B., Factory at Appleton, Wisconsin, or F.O.B. at a Miller authorized service facility as determined by Miller. Therefore no compensation or reimbursement for transportation costs of any kind will be allowed.

TO THE EXTENT PERMITTED BY LAW, THE REMEDIES PROVIDED HEREIN ARE THE SOLE AND EXCLUSIVE REMEDIES. IN NO EVENT SHALL MILLER BE LIABLE FOR DIRECT, INDIRECT, SPECIAL, INCIDENTAL OR CONSEQUENTIAL DAMAGES (INCLUDING LOSS OF PROFIT), WHETHER BASED ON CONTRACT, TORT OR ANY OTHER LEGAL THEORY.

ANY EXPRESS WARRANTY NOT PROVIDED HEREIN AND ANY IMPLIED WARRANTY, GUARANTY OR REPRESENTATION AS TO PERFORMANCE, AND ANY REMEDY FOR BREACH OF CONTRACT TORT OR ANY OTHER LEGAL THEORY WHICH, BUT FOR THIS PROVISION, MIGHT ARISE BY IMPLICATION, OPERATION OF LAW, CUSTOM OF TRADE OR COURSE OF DEALING, INCLUDING ANY IMPLIED WARRANTY OF MERCHANTABILITY OR FITNESS FOR PARTICULAR PURPOSE, WITH RESPECT TO ANY AND ALL EQUIPMENT FURNISHED BY MILLER IS EXCLUDED AND DISCLAIMED BY MILLER.

Some states in the U.S.A. do not allow limitations of how long an implied warranty lasts, or the exclusion of incidental, indirect, special or consequential damages, so the above limitation or exclusion may not apply to you. This warranty provides specific legal rights, and other rights may be available, but may vary from state to state.

In Canada, legislation in some provinces provides for certain additional warranties or remedies other than as stated herein, and to the extent that they may not be waived, the limitations and exclusions set out above may not apply. This Limited Warranty provides specific legal rights, and other rights may be available, but may vary from province to province.

Warranty Questions?

Call
1-800-4-A-MILLER
for your local
Miller distributor.

Your distributor also gives you ...

Service

You always get the fast, reliable response you need. Most replacement parts can be in your hands in 24 hours.

Support

Need fast answers to the tough welding questions? Contact your distributor. The expertise of the distributor and Miller is there to help you, every step of the way.





Owner's Record

Please complete and retain with your personal records.

Model Name

Serial/Style Number

Purchase Date

(Date which equipment was delivered to original customer.)

Distributor

Address

City

State

Zip



Resources Available

Always provide Model Name and Serial/Style Number.

Contact your Distributor for:

To locate distributor nearest you call
1-800-4-A-Miller

Welding Supplies and Consumables

Options and Accessories

Personal Safety Equipment

Service and Repair

Replacement Parts

Training (Schools, Videos, Books)

Technical Manuals (Servicing Information
and Parts)

Circuit Diagrams

Welding Process Handbooks

Contact the Delivering Carrier for:

For assistance in filing or settling claims,
contact your distributor and/or equipment
manufacturer's Transportation Department.

File a claim for loss or damage during
shipment.

Miller Electric Mfg. Co.

An Illinois Tool Works Company
1635 West Spencer Street
Appleton, WI 54914 USA

International Headquarters—USA

USA Phone: 920-735-4505 Auto-Attended
USA & Canada FAX: 920-735-4134
International FAX: 920-735-4125

European Headquarters – United Kingdom

Phone: 44 (0) 1204-593493
FAX: 44 (0) 1204-598066

www.MillerWelds.com



Miller
The Power of Blue.