



OM-1325

204 902A

January 2002

Processes



MIG (GMAW) Welding



Flux Cored (FCAW) Welding

Description



Arc Welding Power Source
and Wire Feeder

Millermatic[®] 210 And M-25 Gun

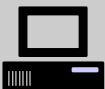
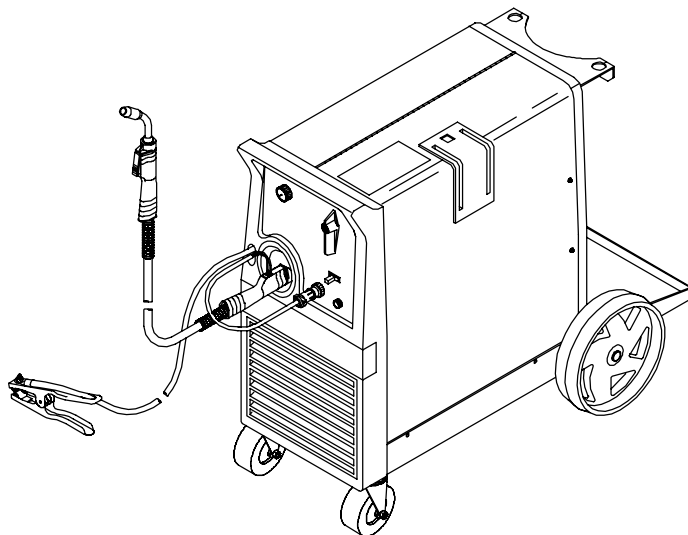

Visit our website at
www.MillerWelds.com

OWNER'S MANUAL

MANUAL DEL OPERADOR

(cuando disponible) sigue al manual en inglés

From Miller to You

Thank you and congratulations on choosing Miller. Now you can get the job done and get it done right. We know you don't have time to do it any other way.

That's why when Niels Miller first started building arc welders in 1929, he made sure his products offered long-lasting value and superior quality. Like you, his customers couldn't afford anything less. Miller products had to be more than the best they could be. They had to be the best you could buy.



Today, the people that build and sell Miller products continue the tradition. They're just as committed to providing equipment and service that meets the high standards of quality and value established in 1929.

This Owner's Manual is designed to help you get the most out of your Miller products. Please take time to read the Safety precautions. They will help you protect yourself against potential hazards on the worksite.



Miller is the first welding equipment manufacturer in the U.S.A. to be registered to the ISO 9001 Quality System Standard.

We've made installation and operation quick and easy. With Miller you can count on years of reliable service with proper maintenance. And if for some reason the unit needs repair, there's a Troubleshooting section that will help you figure out what the problem is. The parts list will then help you to decide which exact part you may need to fix the problem. Warranty and service information for your particular model are also provided.



Miller Electric manufactures a full line of welders and welding related equipment. For information on other quality Miller products, contact your local Miller distributor to receive the latest full line catalog or individual catalog sheets. **To locate your nearest distributor or service agency call 1-800-4-A-Miller, or visit us at www.MillerWelds.com on the web.**

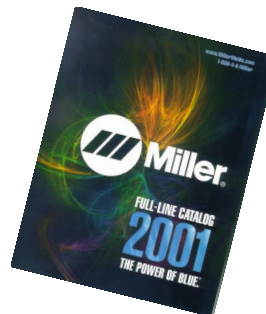

Working as hard as you do – every power source from Miller is backed by the most hassle-free warranty in the business.

Miller offers a Technical Manual which provides more detailed service and parts information for your unit. To obtain a Technical Manual, contact your local distributor. Your distributor can also supply you with Welding Process Manuals such as SMAW, GTAW, GMAW, and GMAW-P.



TABLE OF CONTENTS

WARNING

This product, when used for welding or cutting, produces fumes or gases which contain chemicals known to the State of California to cause birth defects and, in some cases, cancer. (California Health & Safety Code Section 25249.5 et seq.)

The following terms are used interchangeably throughout this manual:
MIG = GMAW

SECTION 1 – SAFETY PRECAUTIONS - READ BEFORE USING	1
1-1. Symbol Usage	1
1-2. Arc Welding Hazards	1
1-3. Additional Symbols For Installation, Operation, And Maintenance	3
1-4. Principal Safety Standards	3
1-5. EMF Information	4
SECTION 1 – CONSIGNES DE SECURITE – LIRE AVANT UTILISATION	5
1-1. Signification des symboles	5
1-2. Dangers relatifs au soudage à l'arc	5
1-3. Dangers supplémentaires en relation avec l'installation, le fonctionnement et la maintenance	7
1-4. Principales normes de sécurité	8
1-5. Information sur les champs électromagnétiques	8
SECTION 2 – INSTALLATION	9
2-1. Welding Power Source And MIG Gun Specifications	9
2-2. Welding Power Source Duty Cycle And Overheating	9
2-3. MIG Welding Gun Duty Cycle And Overheating	10
2-4. Volt-Ampere Curves	10
2-5. Installing Work Clamp	11
2-6. Installing Welding Gun	11
2-7. Connecting An Optional Spool Gun	12
2-8. Setting Gun Polarity For Wire Type	12
2-9. Installing Gas Supply	13
2-10. Installing MIG Wire Spool and Adjusting Hub Tension	14
2-11. Positioning Jumper Links	15
2-12. Electrical Service Guide	15
2-13. Selecting A Location And Connecting Input Power	16
2-14. Threading Welding Wire	17
2-15. Using Gun/Cable Holder	18
SECTION 3 – OPERATION	19
3-1. Controls	19
3-2. Weld Parameter Chart	20
SECTION 4 – MAINTENANCE & TROUBLESHOOTING	22
4-1. Routine Maintenance	22
4-2. Circuit Breaker CB1	22
4-3. Unit Overload	22
4-4. Replacing Gun Contact Tip	23
4-5. Changing Drive Roll and Wire Inlet Guide	23
4-6. Aligning Drive Rolls and Wire Guide	24
4-7. Cleaning Or Replacing Gun Liner	25
4-8. Replacing Switch And/Or Head Tube	26
4-9. Troubleshooting	27
SECTION 5 – ELECTRICAL DIAGRAM	28

TABLE OF CONTENTS

SECTION 6 – MIG WELDING (GMAW) GUIDELINES	29
6-1. Typical MIG Process Connections	29
6-2. Typical MIG Process Control Settings	30
6-3. Holding And Positioning Welding Gun	31
6-4. Conditions That Affect Weld Bead Shape	32
6-5. Gun Movement During Welding	33
6-6. Poor Weld Bead Characteristics	33
6-7. Good Weld Bead Characteristics	33
6-8. Troubleshooting – Excessive Spatter	34
6-9. Troubleshooting – Porosity	34
6-10. Troubleshooting – Excessive Penetration	34
6-11. Troubleshooting – Lack Of Penetration	35
6-12. Troubleshooting – Incomplete Fusion	35
6-13. Troubleshooting – Burn-Through	35
6-14. Troubleshooting – Waviness Of Bead	36
6-15. Troubleshooting – Distortion	36
6-16. Common MIG Shielding Gases	37
6-17. Troubleshooting Guide For Semiautomatic Welding Equipment	37
SECTION 7 – PARTS LIST	40
OPTIONS AND ACCESSORIES	
WARRANTY	

SECTION 1 – SAFETY PRECAUTIONS - READ BEFORE USING

som_nd_4/98

1-1. Symbol Usage



Means Warning! Watch Out! There are possible hazards with this procedure! The possible hazards are shown in the adjoining symbols.

▲ Marks a special safety message.

☞ Means "Note"; not safety related.



This group of symbols means Warning! Watch Out! possible ELECTRIC SHOCK, MOVING PARTS, and HOT PARTS hazards. Consult symbols and related instructions below for necessary actions to avoid the hazards.

1-2. Arc Welding Hazards

▲ The symbols shown below are used throughout this manual to call attention to and identify possible hazards. When you see the symbol, watch out, and follow the related instructions to avoid the hazard. The safety information given below is only a summary of the more complete safety information found in the Safety Standards listed in Section 1-4. Read and follow all Safety Standards.

▲ Only qualified persons should install, operate, maintain, and repair this unit.

▲ During operation, keep everybody, especially children, away.



ELECTRIC SHOCK can kill.

Touching live electrical parts can cause fatal shocks or severe burns. The electrode and work circuit is electrically live whenever the output is on. The input power circuit and machine internal circuits are also

live when power is on. In semiautomatic or automatic wire welding, the wire, wire reel, drive roll housing, and all metal parts touching the welding wire are electrically live. Incorrectly installed or improperly grounded equipment is a hazard.

- Do not touch live electrical parts.
- Wear dry, hole-free insulating gloves and body protection.
- Insulate yourself from work and ground using dry insulating mats or covers big enough to prevent any physical contact with the work or ground.
- Do not use AC output in damp areas, if movement is confined, or if there is a danger of falling.
- Use AC output ONLY if required for the welding process.
- If AC output is required, use remote output control if present on unit.
- Disconnect input power or stop engine before installing or servicing this equipment. Lockout/tagout input power according to OSHA 29 CFR 1910.147 (see Safety Standards).
- Properly install and ground this equipment according to its Owner's Manual and national, state, and local codes.
- Always verify the supply ground – check and be sure that input power cord ground wire is properly connected to ground terminal in disconnect box or that cord plug is connected to a properly grounded receptacle outlet.
- When making input connections, attach proper grounding conductor first – double-check connections.
- Frequently inspect input power cord for damage or bare wiring – replace cord immediately if damaged – bare wiring can kill.
- Turn off all equipment when not in use.
- Do not use worn, damaged, undersized, or poorly spliced cables.
- Do not drape cables over your body.

- If earth grounding of the workpiece is required, ground it directly with a separate cable.
- Do not touch electrode if you are in contact with the work, ground, or another electrode from a different machine.
- Use only well-maintained equipment. Repair or replace damaged parts at once. Maintain unit according to manual.
- Wear a safety harness if working above floor level.
- Keep all panels and covers securely in place.
- Clamp work cable with good metal-to-metal contact to workpiece or worktable as near the weld as practical.
- Insulate work clamp when not connected to workpiece to prevent contact with any metal object.
- Do not connect more than one electrode or work cable to any single weld output terminal.

SIGNIFICANT DC VOLTAGE exists after removal of input power on inverters.

- Turn Off inverter, disconnect input power, and discharge input capacitors according to instructions in Maintenance Section before touching any parts.

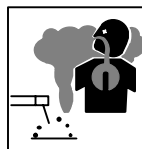

FUMES AND GASES can be hazardous.

Welding produces fumes and gases. Breathing these fumes and gases can be hazardous to your health.

- Keep your head out of the fumes. Do not breathe the fumes.
- If inside, ventilate the area and/or use exhaust at the arc to remove welding fumes and gases.
- If ventilation is poor, use an approved air-supplied respirator.
- Read the Material Safety Data Sheets (MSDSs) and the manufacturer's instructions for metals, consumables, coatings, cleaners, and degreasers.
- Work in a confined space only if it is well ventilated, or while wearing an air-supplied respirator. Always have a trained watch-person nearby. Welding fumes and gases can displace air and lower the oxygen level causing injury or death. Be sure the breathing air is safe.
- Do not weld in locations near degreasing, cleaning, or spraying operations. The heat and rays of the arc can react with vapors to form highly toxic and irritating gases.
- Do not weld on coated metals, such as galvanized, lead, or cadmium plated steel, unless the coating is removed from the weld area, the area is well ventilated, and if necessary, while wearing an air-supplied respirator. The coatings and any metals containing these elements can give off toxic fumes if welded.



ARC RAYS can burn eyes and skin.

Arc rays from the welding process produce intense visible and invisible (ultraviolet and infrared) rays that can burn eyes and skin. Sparks fly off from the weld.

- Wear a welding helmet fitted with a proper shade of filter to protect your face and eyes when welding or watching (see ANSI Z49.1 and Z87.1 listed in Safety Standards).
- Wear approved safety glasses with side shields under your helmet.
- Use protective screens or barriers to protect others from flash and glare; warn others not to watch the arc.
- Wear protective clothing made from durable, flame-resistant material (leather and wool) and foot protection.



WELDING can cause fire or explosion.

Welding on closed containers, such as tanks, drums, or pipes, can cause them to blow up. Sparks can fly off from the welding arc. The flying sparks, hot workpiece, and hot equipment can cause fires and burns. Accidental contact of electrode to metal objects can cause sparks, explosion, overheating, or fire. Check and be sure the area is safe before doing any welding.

- Protect yourself and others from flying sparks and hot metal.
- Do not weld where flying sparks can strike flammable material.
- Remove all flammables within 35 ft (10.7 m) of the welding arc. If this is not possible, tightly cover them with approved covers.
- Be alert that welding sparks and hot materials from welding can easily go through small cracks and openings to adjacent areas.
- Watch for fire, and keep a fire extinguisher nearby.
- Be aware that welding on a ceiling, floor, bulkhead, or partition can cause fire on the hidden side.
- Do not weld on closed containers such as tanks, drums, or pipes, unless they are properly prepared according to AWS F4.1 (see Safety Standards).
- Connect work cable to the work as close to the welding area as practical to prevent welding current from traveling long, possibly unknown paths and causing electric shock and fire hazards.
- Do not use welder to thaw frozen pipes.
- Remove stick electrode from holder or cut off welding wire at contact tip when not in use.
- Wear oil-free protective garments such as leather gloves, heavy shirt, cuffless trousers, high shoes, and a cap.
- Remove any combustibles, such as a butane lighter or matches, from your person before doing any welding.

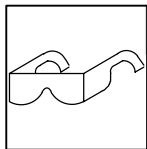

FLYING METAL can injure eyes.

- Welding, chipping, wire brushing, and grinding cause sparks and flying metal. As welds cool, they can throw off slag.
- Wear approved safety glasses with side shields even under your welding helmet.



BUILDUP OF GAS can injure or kill.

- Shut off shielding gas supply when not in use.
- Always ventilate confined spaces or use approved air-supplied respirator.

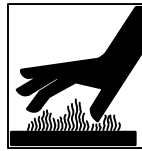

HOT PARTS can cause severe burns.

- Do not touch hot parts bare handed.
- Allow cooling period before working on gun or torch.

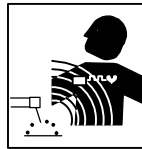

MAGNETIC FIELDS can affect pacemakers.

- Pacemaker wearers keep away.
- Wearers should consult their doctor before going near arc welding, gouging, or spot welding operations.

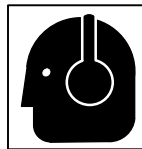

NOISE can damage hearing.

Noise from some processes or equipment can damage hearing.

- Wear approved ear protection if noise level is high.

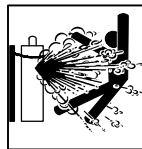

CYLINDERS can explode if damaged.

Shielding gas cylinders contain gas under high pressure. If damaged, a cylinder can explode. Since gas cylinders are normally part of the welding process, be sure to treat them carefully.

- Protect compressed gas cylinders from excessive heat, mechanical shocks, slag, open flames, sparks, and arcs.
- Install cylinders in an upright position by securing to a stationary support or cylinder rack to prevent falling or tipping.
- Keep cylinders away from any welding or other electrical circuits.
- Never drape a welding torch over a gas cylinder.
- Never allow a welding electrode to touch any cylinder.
- Never weld on a pressurized cylinder – explosion will result.
- Use only correct shielding gas cylinders, regulators, hoses, and fittings designed for the specific application; maintain them and associated parts in good condition.
- Turn face away from valve outlet when opening cylinder valve.
- Keep protective cap in place over valve except when cylinder is in use or connected for use.
- Read and follow instructions on compressed gas cylinders, associated equipment, and CGA publication P-1 listed in Safety Standards.

1-3. Additional Symbols For Installation, Operation, And Maintenance



FIRE OR EXPLOSION hazard.

- Do not install or place unit on, over, or near combustible surfaces.
- Do not install unit near flammables.
- Do not overload building wiring – be sure power supply system is properly sized, rated, and protected to handle this unit.



MOVING PARTS can cause injury.

- Keep away from moving parts such as fans.
- Keep all doors, panels, covers, and guards closed and securely in place.



FALLING UNIT can cause injury.

- Use lifting eye to lift unit only, NOT running gear, gas cylinders, or any other accessories.
- Use equipment of adequate capacity to lift and support unit.
- If using lift forks to move unit, be sure forks are long enough to extend beyond opposite side of unit.

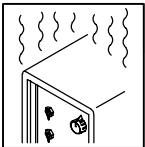

OVERUSE can cause OVERHEATING

- Allow cooling period; follow rated duty cycle.
- Reduce current or reduce duty cycle before starting to weld again.
- Do not block or filter airflow to unit.



STATIC (ESD) can damage PC boards.

- Put on grounded wrist strap BEFORE handling boards or parts.
- Use proper static-proof bags and boxes to store, move, or ship PC boards.



MOVING PARTS can cause injury.

- Keep away from moving parts.
- Keep away from pinch points such as drive rolls.



WELDING WIRE can cause injury.

- Do not press gun trigger until instructed to do so.
- Do not point gun toward any part of the body, other people, or any metal when threading welding wire.

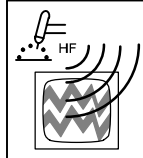

H.F. RADIATION can cause interference.

- High-frequency (H.F.) can interfere with radio navigation, safety services, computers, and communications equipment.
- Have only qualified persons familiar with electronic equipment perform this installation.
- The user is responsible for having a qualified electrician promptly correct any interference problem resulting from the installation.
- If notified by the FCC about interference, stop using the equipment at once.
- Have the installation regularly checked and maintained.
- Keep high-frequency source doors and panels tightly shut, keep spark gaps at correct setting, and use grounding and shielding to minimize the possibility of interference.

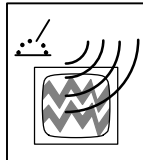

ARC WELDING can cause interference.

- Electromagnetic energy can interfere with sensitive electronic equipment such as computers and computer-driven equipment such as robots.
- Be sure all equipment in the welding area is electromagnetically compatible.
- To reduce possible interference, keep weld cables as short as possible, close together, and down low, such as on the floor.
- Locate welding operation 100 meters from any sensitive electronic equipment.
- Be sure this welding machine is installed and grounded according to this manual.
- If interference still occurs, the user must take extra measures such as moving the welding machine, using shielded cables, using line filters, or shielding the work area.

1-4. Principal Safety Standards

Safety in Welding and Cutting, ANSI Standard Z49.1, from American Welding Society, 550 N.W. LeJeune Rd, Miami FL 33126

Safety and Health Standards, OSHA 29 CFR 1910, from Superintendent of Documents, U.S. Government Printing Office, Washington, D.C. 20402.

Recommended Safe Practices for the Preparation for Welding and Cutting of Containers That Have Held Hazardous Substances, American Welding Society Standard AWS F4.1, from American Welding Society, 550 N.W. LeJeune Rd, Miami, FL 33126

National Electrical Code, NFPA Standard 70, from National Fire Protection Association, Batterymarch Park, Quincy, MA 02269.

Safe Handling of Compressed Gases in Cylinders, CGA Pamphlet P-1, from Compressed Gas Association, 1235 Jefferson Davis Highway, Suite 501, Arlington, VA 22202.

Code for Safety in Welding and Cutting, CSA Standard W117.2, from Canadian Standards Association, Standards Sales, 178 Rexdale Boulevard, Rexdale, Ontario, Canada M9W 1R3.

Safe Practices For Occupation And Educational Eye And Face Protection, ANSI Standard Z87.1, from American National Standards Institute, 1430 Broadway, New York, NY 10018.

Cutting And Welding Processes, NFPA Standard 51B, from National Fire Protection Association, Batterymarch Park, Quincy, MA 02269.

1-5. EMF Information

Considerations About Welding And The Effects Of Low Frequency Electric And Magnetic Fields

Welding current, as it flows through welding cables, will cause electromagnetic fields. There has been and still is some concern about such fields. However, after examining more than 500 studies spanning 17 years of research, a special blue ribbon committee of the National Research Council concluded that: "The body of evidence, in the committee's judgment, has not demonstrated that exposure to power-frequency electric and magnetic fields is a human-health hazard." However, studies are still going forth and evidence continues to be examined. Until the final conclusions of the research are reached, you may wish to minimize your exposure to electromagnetic fields when welding or cutting.

To reduce magnetic fields in the workplace, use the following procedures:

1. Keep cables close together by twisting or taping them.
2. Arrange cables to one side and away from the operator.
3. Do not coil or drape cables around your body.
4. Keep welding power source and cables as far away from operator as practical.
5. Connect work clamp to workpiece as close to the weld as possible.

About Pacemakers:

Pacemaker wearers consult your doctor first. If cleared by your doctor, then following the above procedures is recommended.

SECTION 1 – CONSIGNES DE SECURITE – LIRE AVANT UTILISATION

som_nd_fre 4/98

1-1. Signification des symboles



Signifie Mise en garde ! Soyez vigilant ! Cette procédure présente des risques de danger ! Ceux-ci sont identifiés par des symboles adjacents aux directives.

▲ Identifie un message de sécurité particulier.

Signifie NOTA ; n'est pas relatif à la sécurité.



Ce groupe de symboles signifie Mise en garde ! Soyez vigilant ! Il y a des risques de danger reliés aux CHOCS ÉLECTRIQUES, aux PIÈCES EN MOUVEMENT et aux PIÈCES CHAUDES. Reportez-vous aux symboles et aux directives ci-dessous afin de connaître les mesures à prendre pour éviter tout danger.

1-2. Dangers relatifs au soudage à l'arc

▲ Les symboles présentés ci-après sont utilisés tout au long du présent manuel pour attirer votre attention et identifier les risques de danger. Lorsque vous voyez un symbole, soyez vigilant et suivez les directives mentionnées afin d'éviter tout danger. Les consignes de sécurité présentées ci-après ne font que résumer l'information contenue dans les normes de sécurité énumérées à la section 1-4. Veuillez lire et respecter toutes ces normes de sécurité.

▲ L'installation, l'utilisation, l'entretien et les réparations ne doivent être confiés qu'à des personnes qualifiées.

▲ Au cours de l'utilisation, tenir toute personne à l'écart et plus particulièrement les enfants.



UN CHOC ÉLECTRIQUE peut tuer.

Un simple contact avec des pièces électriques peut provoquer une électrocution ou des blessures graves. L'électrode et le circuit de soudage sont sous tension dès que l'appareil est sur ON. Le circuit d'entrée et les circuits internes de l'appareil sont également sous tension à ce moment-là. En soudage semi-automatique ou automatique, le fil, le dévidoir, le logement des galets d'entraînement et les pièces métalliques en contact avec le fil de soudage sont sous tension. Des matériels mal installés ou mal mis à la terre présentent un danger.

- Ne jamais toucher les pièces électriques sous tension.
- Porter des gants et des vêtements de protection secs ne comportant pas de trous.
- S'isoler de la pièce et de la terre au moyen de tapis ou d'autres moyens isolants suffisamment grands pour empêcher le contact physique éventuel avec la pièce ou la terre.
- Ne pas se servir de source électrique à courant électrique dans les zones humides, dans les endroits confinés ou là où on risque de tomber.
- Se servir d'une source électrique à courant électrique UNIQUEMENT si le procédé de soudage le demande.
- Si l'utilisation d'une source électrique à courant électrique s'avère nécessaire, se servir de la fonction de télécommande si l'appareil en est équipé.
- Couper l'alimentation ou arrêter le moteur avant de procéder à l'installation, à la réparation ou à l'entretien de l'appareil. Déverrouiller l'alimentation selon la norme OSHA 29 CFR 1910.147 (voir normes de sécurité).
- Installer et mettre à la terre correctement cet appareil conformément à son manuel d'utilisation et aux codes nationaux, provinciaux et municipaux.
- Toujours vérifier la terre du cordon d'alimentation – Vérifier et s'assurer que le fil de terre du cordon d'alimentation est bien raccordé à la borne de terre du sectionneur ou que la fiche du cordon est raccordée à une prise correctement mise à la terre.
- En effectuant les raccordements d'entrée fixer d'abord le conducteur de mise à la terre approprié et contre-vérifier les connexions.
- Vérifier fréquemment le cordon d'alimentation pour voir s'il n'est pas endommagé ou dénudé – remplacer le cordon immédiatement s'il est endommagé – un câble dénudé peut provoquer une électrocution.
- Mettre l'appareil hors tension quand on ne l'utilise pas.
- Ne pas utiliser des câbles usés, endommagés, de grosseur insuffisante ou mal épissés.
- Ne pas enrouler les câbles autour du corps.
- Si la pièce soudée doit être mise à la terre, le faire directement avec un câble distinct.
- Ne pas toucher l'électrode quand on est en contact avec la pièce, la terre ou une électrode provenant d'une autre machine.

- N'utiliser qu'un matériel en bon état. Réparer ou remplacer sur-le-champ les pièces endommagées. Entretien l'appareil conformément à ce manuel.
- Porter un harnais de sécurité quand on travaille en hauteur.
- Maintenir solidement en place tous les panneaux et capots.
- Fixer le câble de retour de façon à obtenir un bon contact métal-métal avec la pièce à souder ou la table de travail, le plus près possible de la soudure.
- Isoler la pince de masse quand pas mis à la pièce pour éviter le contact avec tout objet métallique.

Il y a DU COURANT CONTINU IMPORTANT dans les convertisseurs après la suppression de l'alimentation électrique.

- Arrêter les convertisseurs, débrancher le courant électrique, et décharger les condensateurs d'alimentation selon les instructions indiquées dans la partie entretien avant de toucher les pièces.

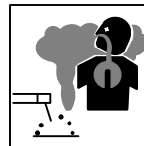

LES FUMÉES ET LES GAZ peuvent être dangereux.

Le soudage génère des fumées et des gaz. Leur inhalation peut être dangereuse pour votre santé.

- Eloigner votre tête des fumées. Ne pas respirer les fumées.
- A l'intérieur, ventiler la zone et/ou utiliser un échappement au niveau de l'arc pour l'évacuation des fumées et des gaz de soudage.
- Si la ventilation est insuffisante, utiliser un respirateur à alimentation d'air homologué.
- Lire les spécifications de sécurité des matériaux (MSDSs) et les instructions du fabricant concernant les métaux, les consommables, les revêtements, les nettoyants et les dégraissants.
- Travailler dans un espace fermé seulement s'il est bien ventilé et en portant un respirateur à alimentation d'air. Demander toujours à un surveillant dûment formé de se tenir à proximité. Des fumées et des gaz de soudage peuvent déplacer l'air et abaisser le niveau d'oxygène provoquant des blessures ou des accidents mortels. S'assurer que l'air de respiration ne présente aucun danger.
- Ne pas souder dans des endroits situés à proximité d'opérations de dégraissage, de nettoyage ou de pulvérisation. La chaleur et les rayons de l'arc peuvent réagir en présence de vapeurs et former des gaz hautement toxiques et irritants.
- Ne pas souder des métaux munis d'un revêtement, tels que l'acier galvanisé, plaqué en plomb ou au cadmium à moins que le revêtement n'ait été enlevé dans la zone de soudure, que l'endroit soit bien ventilé, et si nécessaire, en portant un respirateur à alimentation d'air. Les revêtements et tous les métaux renfermant ces éléments peuvent dégager des fumées toxiques en cas de soudage.



LES RAYONS DE L'ARC peuvent provoquer des brûlures dans les yeux et sur la peau.

Le rayonnement de l'arc du procédé de soudage génère des rayons visibles et invisibles intenses (ultraviolets et infrarouges) susceptibles de provoquer des brûlures dans les yeux et sur la peau. Des étincelles sont projetées pendant le soudage.

- Porter un casque de soudage muni d'un écran de filtre approprié pour protéger votre visage et vos yeux pendant le soudage ou pour regarder (voir ANSI Z49.1 et Z87.1 énuméré dans les normes de sécurité).
- Porter des protections approuvés pour les oreilles si le niveau sonore est trop élevé.
- Utiliser des écrans ou des barrières pour protéger des tiers de l'éclair et de l'éblouissement; demander aux autres personnes de ne pas regarder l'arc.
- Porter des vêtements de protection constitué dans une matière durable, résistant au feu (cuir ou laine) et une protection des pieds.



LE SOUDAGE peut provoquer un incendie ou une explosion.

Le soudage effectué sur des conteneurs fermés tels que des réservoirs, tambours ou des conduites peut provoquer leur éclatement. Des étincelles peuvent être projetées de l'arc de soudure. La projection d'étincelles, des pièces chaudes et des équipements chauds peut provoquer des incendies et des brûlures. Le contact accidentel de l'électrode avec des objets métalliques peut provoquer des étincelles, une explosion, un surchauffement ou un incendie. Avant de commencer le soudage, vérifier et s'assurer que l'endroit ne présente pas de danger.

- Se protéger et d'autres personnes de la projection d'étincelles et de métal chaud.
- Ne pas souder dans un endroit là où des étincelles peuvent tomber sur des substances inflammables.
- Déplacer toutes les substances inflammables à une distance de 10,7 m de l'arc de soudage. En cas d'impossibilité les recouvrir soigneusement avec des protections homologués.
- Des étincelles et des matériaux chauds du soudage peuvent facilement passer dans d'autres zones en traversant de petites fissures et des ouvertures.
- Surveiller tout déclenchement d'incendie et tenir un extincteur à proximité.
- Le soudage effectué sur un plafond, plancher, paroi ou séparation peut déclencher un incendie de l'autre côté.
- Ne pas effectuer le soudage sur des conteneurs fermés tels que des réservoirs, tambours, ou conduites, à moins qu'ils n'aient été préparés correctement conformément à AWS F4.1 (voir les normes de sécurité).
- Brancher le câble sur la pièce le plus près possible de la zone de soudage pour éviter le transport du courant sur une longue distance par des chemins inconnus éventuels en provoquant des risques d'électrocution et d'incendie.
- Ne pas utiliser le poste de soudage pour dégeler des conduites gelées.
- En cas de non utilisation, enlever la bague d'électrode du porte-électrode ou couper le fil à la pointe de contact.
- Porter des vêtements de protection dépourvus d'huile tels que des gants en cuir, une chemise en matériau lourd, des pantalons sans revers, des chaussures hautes et un couvre chef.
- Avant de souder, retirer toute substance combustible de vos poches telles qu'un allumeur au butane ou des allumettes.



DES PARTICULES VOLANTES peuvent blesser les yeux.

- Le soudage, l'écaillage, le passage de la pièce à la brosse en fil de fer, et le meulage génèrent des étincelles et des particules métalliques volantes. Pendant la période de refroidissement des soudures, elles risquent de projeter du laitier.
- Porter des lunettes de sécurité avec écrans latéraux ou un écran facial.



LES ACCUMULATIONS DE GAZ risquent de provoquer des blessures ou même la mort.

- Fermer l'alimentation du gaz protecteur en cas de non utilisation.
- Veiller toujours à bien aérer les espaces confinés ou se servir d'un respirateur d'adduction d'air homologué.



DES PIÈCES CHAUDES peuvent provoquer des brûlures graves.

- Ne pas toucher des parties chaudes à mains nues
- Prévoir une période de refroidissement avant d'utiliser le pistolet ou la torche.

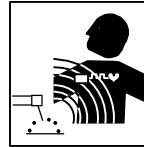

LES CHAMPS MAGNÉTIQUES peuvent affecter les stimulateurs cardiaques.

- Porteurs de stimulateur cardiaque, restez à distance.
- Les porteurs d'un stimulateur cardiaque doivent d'abord consulter leur médecin avant de s'approcher des opérations de soudage à l'arc, de gougeage ou de soudage par points.

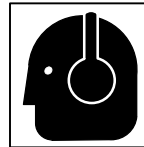

LE BRUIT peut affecter l'ouïe.

Le bruit des processus et des équipements peut affecter l'ouïe.

- Porter des protections approuvés pour les oreilles si le niveau sonore est trop élevé.

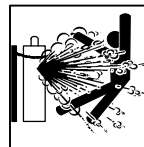

Si des BOUTEILLES sont endommagées, elles pourront exploser.

Des bouteilles de gaz protecteur contiennent du gaz sous haute pression. Si une bouteille est endommagée, elle peut exploser. Du fait que les bouteilles de gaz font normalement partie du procédé de soudage, les manipuler avec précaution.

- Protéger les bouteilles de gaz comprimé d'une chaleur excessive, des chocs mécaniques, du laitier, des flammes ouvertes, des étincelles et des arcs.
- Placer les bouteilles debout en les fixant dans un support stationnaire ou dans un porte-bouteilles pour les empêcher de tomber ou de se renverser.
- Tenir les bouteilles éloignées des circuits de soudage ou autres circuits électriques.
- Ne jamais placer une torche de soudage sur une bouteille à gaz.
- Une électrode de soudage ne doit jamais entrer en contact avec une bouteille.
- Ne jamais souder une bouteille pressurisée – risque d'explosion.
- Utiliser seulement des bouteilles de gaz protecteur, régulateurs, tuyaux et raccords convenables pour cette application spécifique; les maintenir ainsi que les éléments associés en bon état.
- Ne pas tenir la tête en face de la sortie en ouvrant la soupape de la bouteille.
- Maintenir le chapeau de protection sur la soupape, sauf en cas d'utilisation ou de branchement de la bouteille.
- Lire et suivre les instructions concernant les bouteilles de gaz comprimé, les équipements associés et les publications P-1 CGA énumérées dans les normes de sécurité.

1-3. Dangers supplémentaires en relation avec l'installation, le fonctionnement et la maintenance



Risque D'INCENDIE OU D'EXPLOSION.

- Ne pas placer l'appareil sur, au-dessus ou à proximité de surfaces inflammables.
- Ne pas installer l'appareil à proximité de produits inflammables
- Ne pas surcharger l'installation électrique – s'assurer que l'alimentation est correctement dimensionnée et protégé avant de mettre l'appareil en service.



LA CHUTE DE L'APPAREIL peut blesser.

- Utiliser l'anneau de levage uniquement pour soulever l'appareil, NON PAS les chariot, les bouteilles de gaz ou tout autre accessoire.
- Utiliser un engin d'une capacité appropriée pour soulever l'appareil.
- En utilisant des fourches de levage pour déplacer l'unité, s'assurer que les fourches sont suffisamment longues pour dépasser du côté opposé de l'appareil.

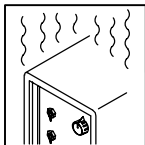

L'EMPLOI EXCESSIF peut SURCHAUFFER L'ÉQUIPEMENT.

- Prévoir une période de refroidissement, respecter le cycle opératoire nominal.
- Réduire le courant ou le cycle opératoire avant de recommencer le soudage.
- Ne pas obstruer les passages d'air du poste.

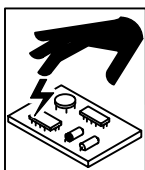

LES CHARGES ÉLECTROSTATIQUES peuvent endommager les circuits imprimés.

- Établir la connexion avec la barrette de terre avant de manipuler des cartes ou des pièces.
- Utiliser des pochettes et des boîtes antistatiques pour stocker, déplacer ou expédier des cartes de circuits imprimés.

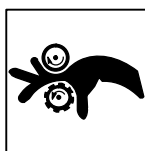

DES ORGANES MOBILES peuvent provoquer des blessures.

- Ne pas s'approcher des organes mobiles.
- Ne pas s'approcher des points de coincement tels que des rouleaux de commande.



LES FILS DE SOUDAGE peuvent provoquer des blessures.

- Ne pas appuyer sur la gachette avant d'en avoir reçu l'instruction.
- Ne pas diriger le pistolet vers soi, d'autres personnes ou toute pièce mécanique en engageant le fil de soudage.



DES ORGANES MOBILES peuvent provoquer des blessures.

- Rester à l'écart des organes mobiles comme le ventilateur.
- Maintenir fermés et fixement en place les portes, panneaux, recouvrements et dispositifs de protection.

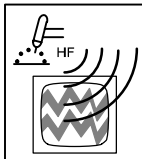

LE RAYONNEMENT HAUTE FRÉQUENCE (H.F.) risque de provoquer des interférences.

- Le rayonnement haute fréquence peut provoquer des interférences avec les équipements de radio-navigation et de communication, les services de sécurité et les ordinateurs.
- Demander seulement à des personnes qualifiées familiarisées avec des équipements électroniques de faire fonctionner l'installation.
- L'utilisateur est tenu de faire corriger rapidement par un électricien qualifié les interférences résultant de l'installation.
- Si le FCC signale des interférences, arrêter immédiatement l'appareil.
- Effectuer régulièrement le contrôle et l'entretien de l'installation.
- Maintenir soigneusement fermés les portes et les panneaux des sources de haute fréquence, maintenir les éclateurs à une distance correcte et utiliser une terre et un blindage pour réduire les interférences éventuelles.

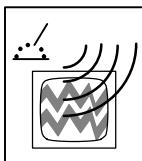

LE SOUDAGE À L'ARC risque de provoquer des interférences.

- L'énergie électromagnétique risque de provoquer des interférences pour l'équipement électronique sensible tel que les ordinateurs et l'équipement commandé par ordinateur tel que les robots.
- Veiller à ce que tout l'équipement de la zone de soudage soit compatible électromagnétiquement.
- Pour réduire la possibilité d'interférence, maintenir les câbles de soudage aussi courts que possible, les grouper, et les poser aussi bas que possible (ex. par terre).
- Veiller à souder à une distance de 100 mètres de tout équipement électronique sensible.
- Veiller à ce que ce poste de soudage soit posé et mis à la terre conformément à ce mode d'emploi.
- En cas d'interférences après avoir pris les mesures précédentes, il incombe à l'utilisateur de prendre des mesures supplémentaires telles que le déplacement du poste, l'utilisation de câbles blindés, l'utilisation de filtres de ligne ou la pose de protecteurs dans la zone de travail.

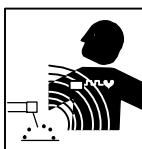

LES CHAMPS MAGNÉTIQUES peuvent affecter les stimulateurs cardiaques.

- Porteurs de stimulateur cardiaque, restez à distance.
- Les porteurs d'un stimulateur cardiaque doivent d'abord consulter leur médecin avant de s'approcher des opérations de soudage à l'arc, de gougeage ou de soudage par points.

1-4. Principales normes de sécurité

Safety in Welding and Cutting, norme ANSI Z49.1, de l'American Welding Society, 550 N.W. Lejeune Rd, Miami FL 33126

Safety and Health Standards, OSHA 29 CFR 1910, du Superintendent of Documents, U.S. Government Printing Office, Washington, D.C. 20402.

Recommended Safe Practice for the Preparation for Welding and Cutting of Containers That Have Held Hazardous Substances, norme AWS F4.1, de l'American Welding Society, 550 N.W. Lejeune Rd, Miami FL 33126

National Electrical Code, NFPA Standard 70, de la National Fire Protection Association, Batterymarch Park, Quincy, MA 02269.

Safe Handling of Compressed Gases in Cylinders, CGA Pamphlet P-1, de la Compressed Gas Association, 1235 Jefferson Davis Highway, Suite 501, Arlington, VA 22202.

Règles de sécurité en soudage, coupage et procédés connexes, norme CSA W117.2, de l'Association canadienne de normalisation, vente de normes, 178 Rexdale Boulevard, Rexdale (Ontario) Canada M9W 1R3.

Safe Practices For Occupation And Educational Eye And Face Protection, norme ANSI Z87.1, de l'American National Standards Institute, 1430 Broadway, New York, NY 10018.

Cutting and Welding Processes, norme NFPA 51B, de la National Fire Protection Association, Batterymarch Park, Quincy, MA 02269.

1-5. Information sur les champs électromagnétiques

Données sur le soudage électrique et sur les effets, pour l'organisme, des champs magnétiques basse fréquence

Le courant de soudage, pendant son passage dans les câbles de soudage, causera des champs électromagnétiques. Il y a eu et il y a encore un certain souci à propos de tels champs. Cependant, après avoir examiné plus de 500 études qui ont été faites pendant une période de recherche de 17 ans, un comité spécial ruban bleu du National Research Council a conclu: "L'accumulation de preuves, suivant le jugement du comité, n'a pas démontré que l'exposition aux champs magnétiques et champs électriques à haute fréquence représente un risque à la santé humaine". Toutefois, des études sont toujours en cours et les preuves continuent à être examinées. En attendant que les conclusions finales de la recherche soient établies, il vous serait souhaitable de réduire votre exposition aux champs électromagnétiques pendant le soudage ou le coupage.

Afin de réduire les champs électromagnétiques dans l'environnement de travail, respecter les consignes suivantes :

- 1 Garder les câbles ensemble en les torsadant ou en les attachant avec du ruban adhésif.
- 2 Mettre tous les câbles du côté opposé de l'opérateur.
- 3 Ne pas courber pas et ne pas entourer pas les câbles autour de votre corps.
- 4 Garder le poste de soudage et les câbles le plus loin possible de vous.
- 5 Relier la pince de masse le plus près possible de la zone de soudure.

Consignes relatives aux stimulateurs cardiaques :

Les personnes qui portent un stimulateur cardiaque doivent avant tout consulter leur docteur. Si vous êtes déclaré apte par votre docteur, il est alors recommandé de respecter les consignes ci-dessus.

SECTION 2 – INSTALLATION



2-1. Welding Power Source And MIG Gun Specifications

Rated Output	Amperage Range DC	Max. Open Circuit Voltage DC	Amps Input at Rated Output, 60 Hz, Single-Phase			
			200 (208) V	230 V	KVA	KW
160 A at 24.5 VDC, 60% Duty Cycle 210 A at 23 VDC 30% Duty Cycle	30-210	34.5	31.2 2.1*	27.1 1.8*	6.36 0.51*	5.45 0.26*

*While idling

Wire Type and Diameter			Wire Feed Speed	Maximum Spool Size	Dimensions	Net Weight
Solid Steel	Stainless Steel	Flux Cored	35-700 IPM (.89-17.8 m/min)	12 in (305 mm) Diameter 33 lb (15 kg)	H: 32 in (813 mm) W: 19 in (483 mm) D: 39 in (991 mm)	215 lb (98 kg)
.023 – .035 in (0.6 – 1.2 mm)	.023 – .035 in (0.6 – 0.9 mm)	.030 – .045 in (0.8 – 1.2 mm)				
Operating Temperature Range -- -20C to +40C			Storage Temperature Range -- -30C to + 50C			

2-2. Welding Power Source Duty Cycle And Overheating

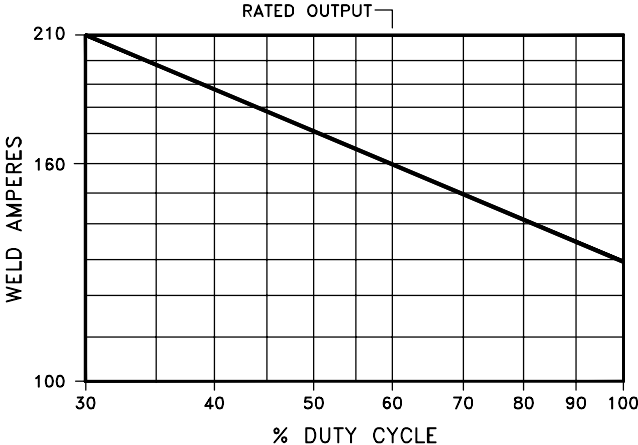

RATED OUTPUT

WELD AMPERES

% DUTY CYCLE

Duty Cycle is percentage of 10 minutes that unit can weld at rated load without overheating.

If unit overheats, thermostat(s) opens, output stops, and cooling fan runs. Wait fifteen minutes for unit to cool. Reduce amperage or voltage, or duty cycle before welding.

▲ Exceeding duty cycle can damage unit and void warranty.

60% Duty Cycle At 160 Amperes

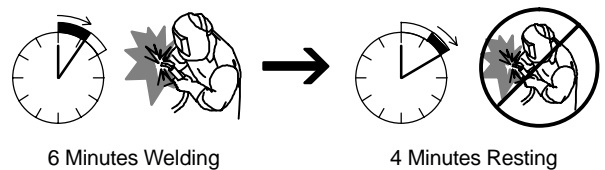

6 Minutes Welding 4 Minutes Resting

30% Duty Cycle At 210 Amperes

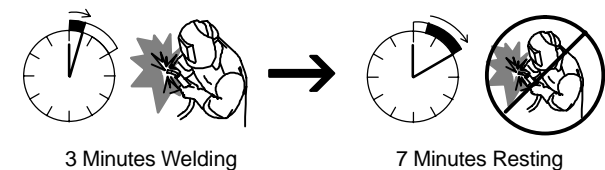

3 Minutes Welding 7 Minutes Resting

Overheating

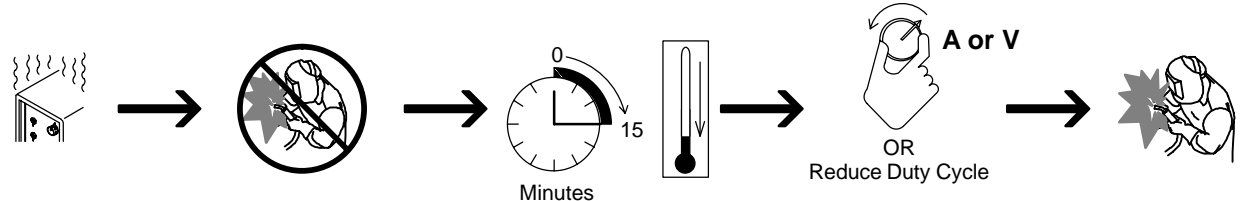

Minutes

A or V
OR
Reduce Duty Cycle

duty1 4/95 – 204 075



2-3. MIG Welding Gun Duty Cycle And Overheating

CAUTION

WELDING LONGER THAN RATED DUTY CYCLE can damage gun and void warranty.

- Do not weld at rated load longer than shown below.
- Using gasless flux cored wire reduces gun duty cycle.

warn7.1 8/93

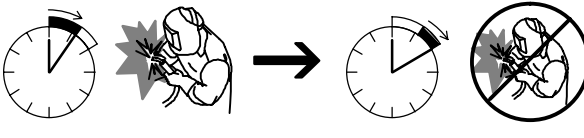
<p>Definition</p>  <p>Duty Cycle is percentage of 10 minutes that gun can weld at rated load without overheating.</p>	<p>.023 To .045 in (0.6 To 1.1 mm) Hard Or Flux Cored Wires</p> <p>100% Duty Cycle At 200 Amperes Using CO₂</p> <p>100% Duty Cycle At 150 Amperes Using Mixed Gases</p>  <p>Continuous Welding</p>	<p>.023 To .045 in (0.6 To 1.1 mm) Hard Or Flux Cored Wires</p> <p>60% Duty Cycle At 300 Amperes Using CO₂</p> <p>60% Duty Cycle At 200 Amperes Using Mixed Gases</p>  <p>6 Minutes Welding 4 Minutes Resting</p>
---	---	--

SB1.1 8/93

2-4. Volt-Ampere Curves

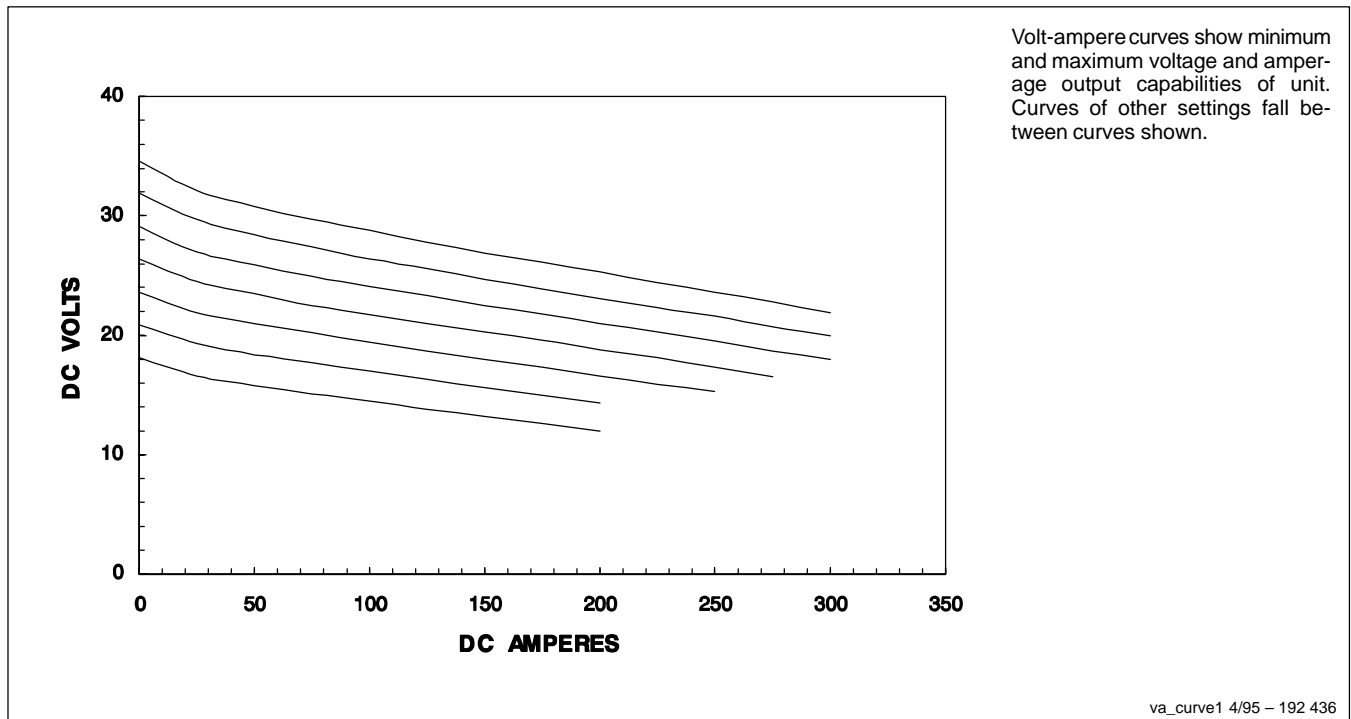

va_curve1 4/95 - 192 436

2-5. Installing Work Clamp

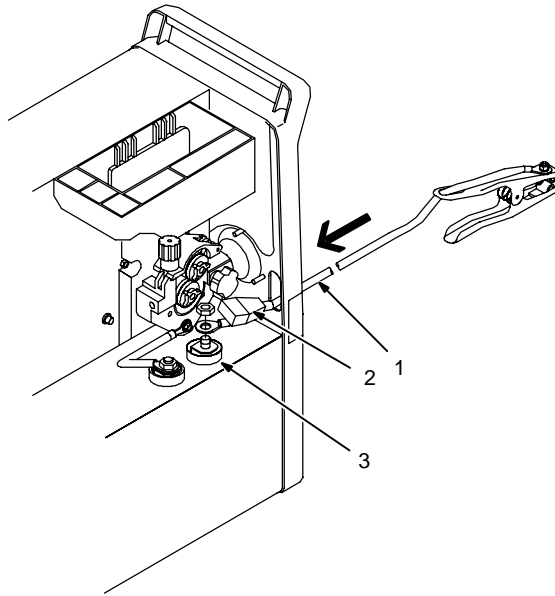

- 1 Work Cable
 - 2 Boot
- Route cable through front panel opening. Slide boot onto work cable.
- 3 Negative (-) Output Terminal
- Connect cable to terminal and cover connection with boot.
Close door.

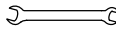
Tools Needed:
 3/4 in

Ref. 802 474-C

2-6. Installing Welding Gun

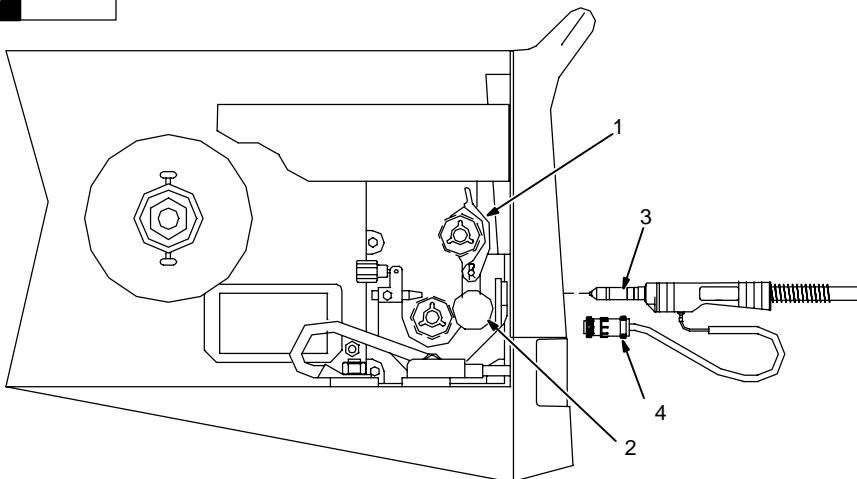

- 1 Drive Assembly
 - 2 Gun Securing Knob
 - 3 Gun End
- Loosen securing knob. Insert gun end through opening until it bottoms against drive assembly (make sure gun end does not touch drive rolls). Tighten knob.
- 4 Gun Trigger Plug
- Insert plug into receptacle, and tighten threaded collar.
Close door.

Ref. 802 064-B

2-7. Connecting An Optional Spool Gun

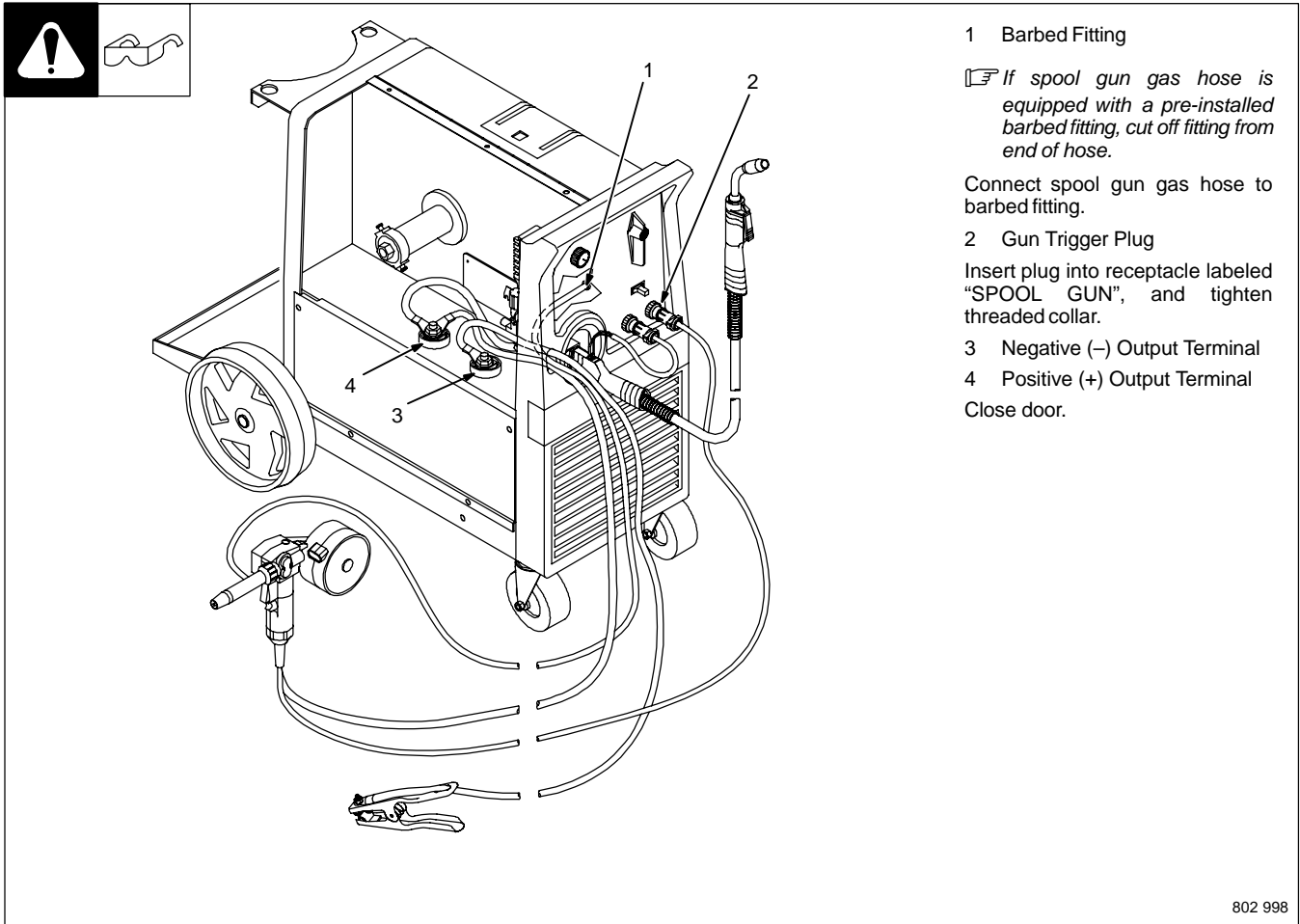

802 998

2-8. Setting Gun Polarity For Wire Type

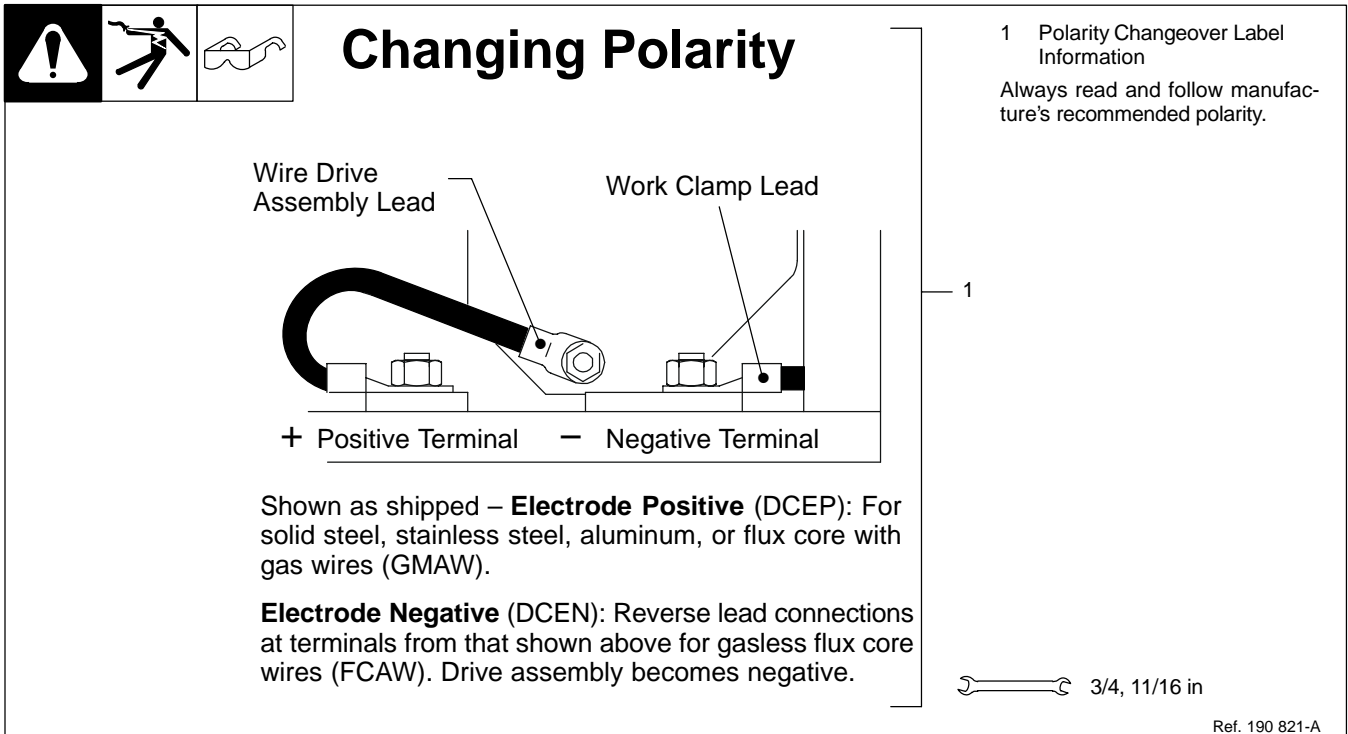

Ref. 190 821-A

2-9. Installing Gas Supply

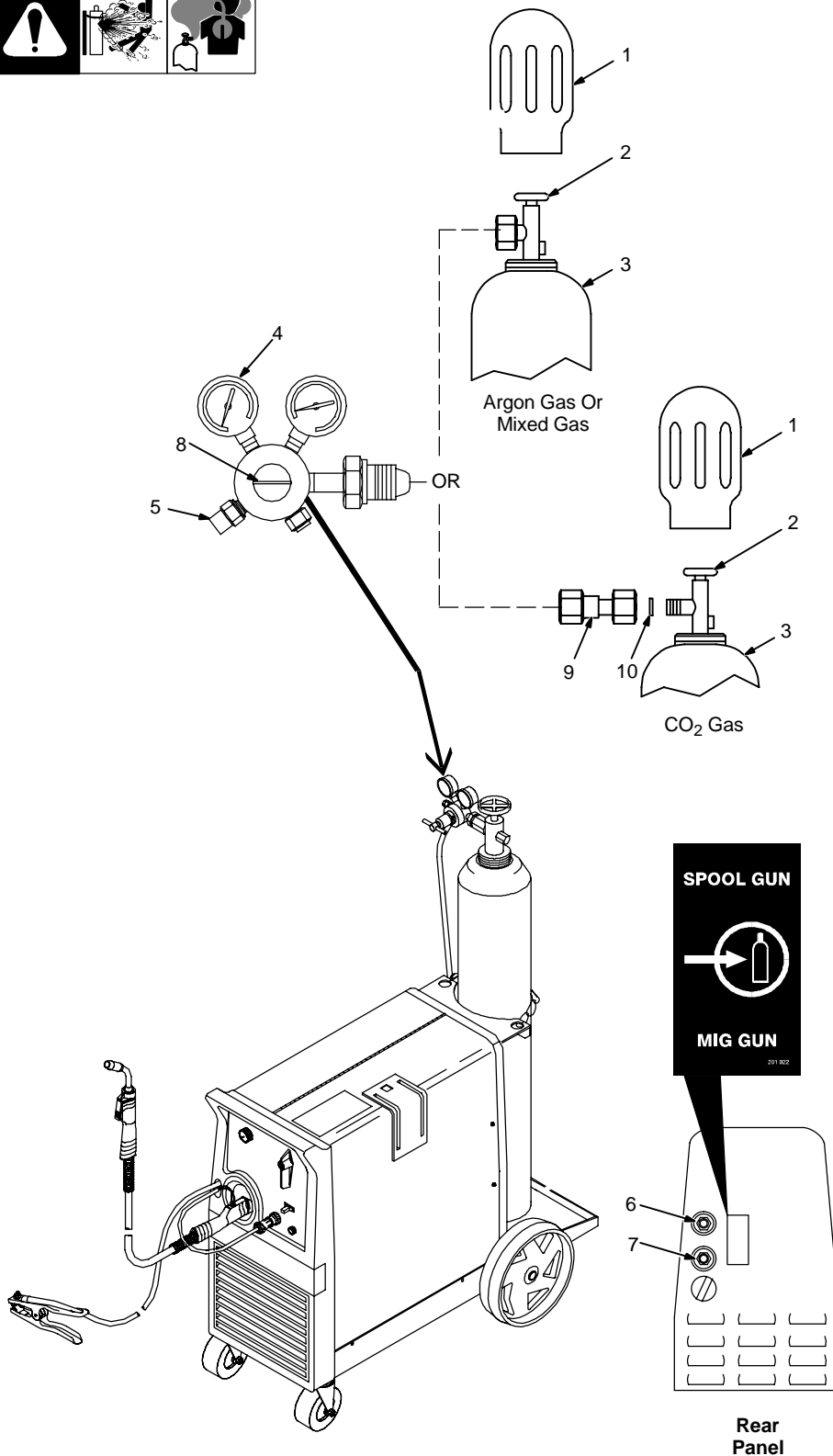

Obtain gas cylinders and chain to running gear, wall, or other stationary support so cylinders cannot fall and break off valve.

- 1 Cap
- 2 Cylinder Valve

Remove cap, stand to side of valve, and open valve slightly. Gas flow blows dust and dirt from valve. Close valve.

- 3 Cylinder
- 4 Regulator/Flowmeter

Install so face is vertical.

- 5 Regulator/Flowmeter Gas Hose Connection
- 6 Welding Power Source Gas Hose Connection For Spool Gun
- 7 Welding Power Source Gas Hose Connection For MIG Gun

Connect gas hose between regulator/flowmeter gas hose connection, and fitting on rear of welding power source.

8 Gas Flow Adjustment Control
Typical flow rate is 25 cfh (cubic feet per hour). Check wire manufacturer's recommended flow rate.

- 9 CO₂ Adapter (Customer Supplied)

- 10 O-Ring (Customer Supplied)

Install adapter with O-ring between regulator/flowmeter and CO₂ cylinder.

Tools Needed:

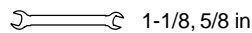

802 028-A / Ref. 802 991

2-10. Installing MIG Wire Spool and Adjusting Hub Tension

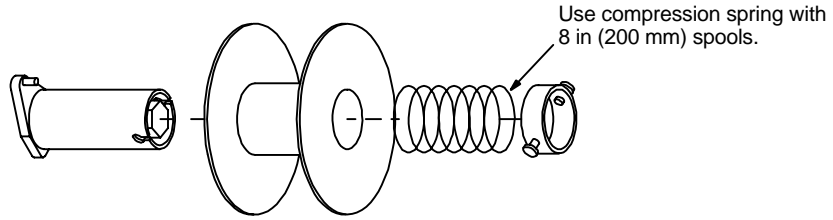

When a slight force is needed to turn spool, tension is set.

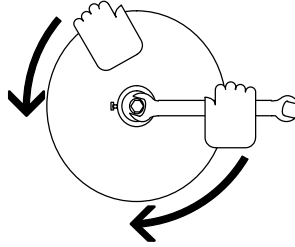

Tools Needed:

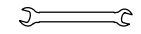

 15/16 in

072573-B

2-11. Positioning Jumper Links



Check input voltage available at site and listed on the machine rating label.

1 Jumper Links Access Door
Open door.

2 Jumper Link Label

Check label – only one is on unit.

3 Input Voltage Jumper Links

Move jumper links to match input voltage.

Close and secure access door.

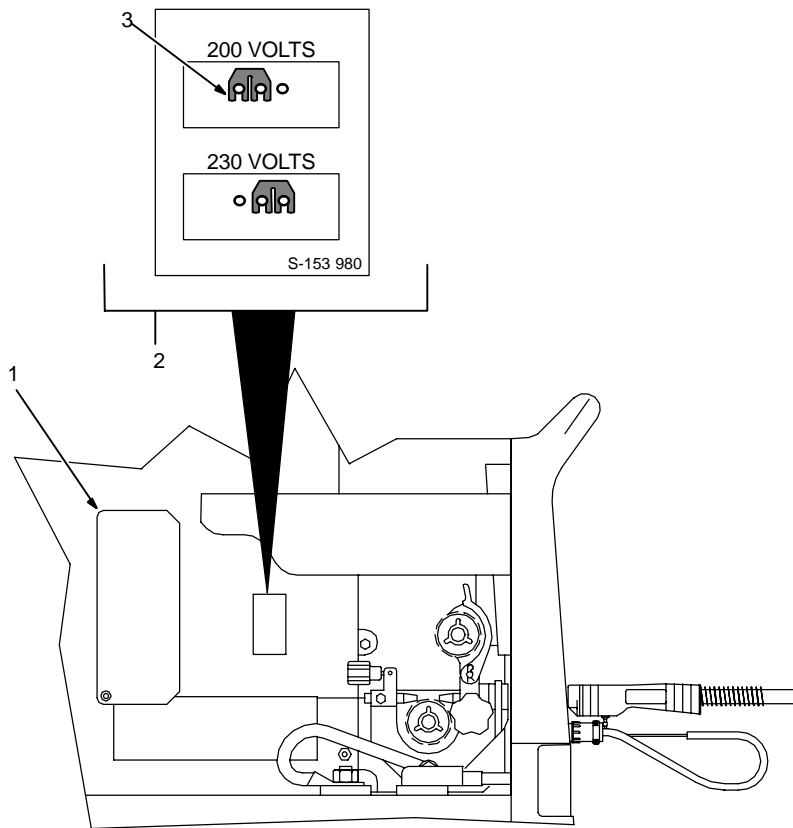

Tools Needed:



Ref. 802 476-B

2-12. Electrical Service Guide

Input Voltage	200	230
Input Amperes At Rated Output	32	28
Max Recommended Standard Fuse Or Circuit Breaker Rating In Amperes		
Circuit Breaker ¹ , Time-Delay ²	35	30
Normal Operating ³	45	40
Min Input Conductor Size In AWG/Kcmil	10	10
Max Recommended Input Conductor Length In Feet (Meters)	89 (27)	118 (36)
Min Grounding Conductor Size In AWG/Kcmil	10	10

Reference: 1999 National Electrical Code (NEC)

1 Choose a circuit breaker with time-current curves comparable to a Time Delay Fuse.

2 "Time-Delay" fuses are UL class "RK5".

3 "Normal Operating" (general purpose – no intentional delay) fuses are UL class "K5" (up to and including 60 amp), and UL class "H" (65 amp and above).

2-13. Selecting A Location And Connecting Input Power

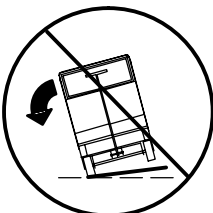
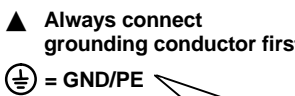
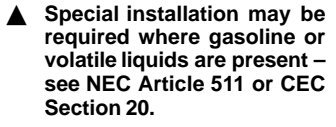
18 in (457 mm) of space for airflow

1 Rating Label
Supply correct input power.

2 Plug (NEMA Type 6-50P)

3 Receptacle (NEMA Type 6-50R)

Connect plug to receptacle.

4 Input And Grounding Conductors

Connect directly to line disconnect device if hard wiring is required.

5 Line Disconnect Device

See Section 2-12.

▲ **Special installation may be required where gasoline or volatile liquids are present – see NEC Article 511 or CEC Section 20.**

▲ **Always connect grounding conductor first.**

⊕ = GND/PE

5

L1

L2

4

2

1

3

L2

L1

230 VAC, 1 ~

802 991

2-14. Threading Welding Wire



- 1 Wire Spool
 - 2 Welding Wire
 - 3 Inlet Wire Guide
 - 4 Pressure Adjustment Knob
 - 5 Drive Roll
 - 6 Outlet Wire Guide
 - 7 Gun Conduit Cable
- Lay gun cable out straight.

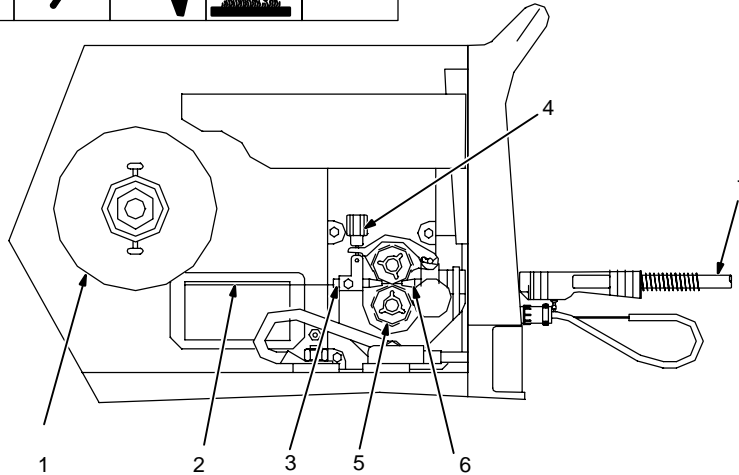

Tools Needed:

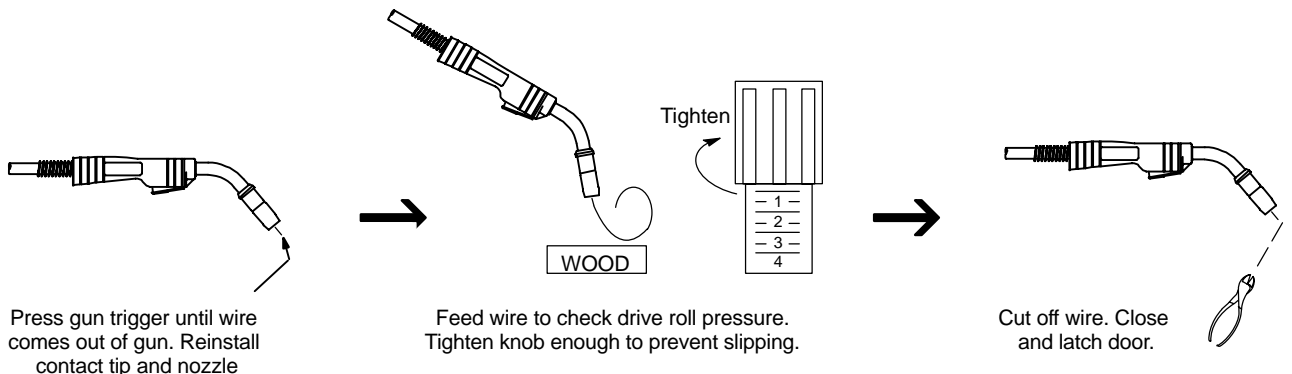
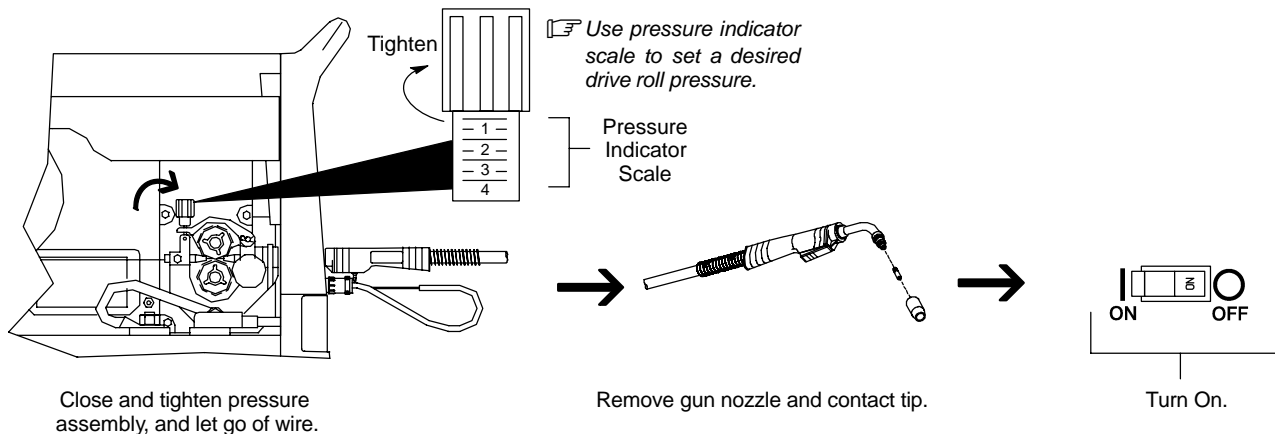
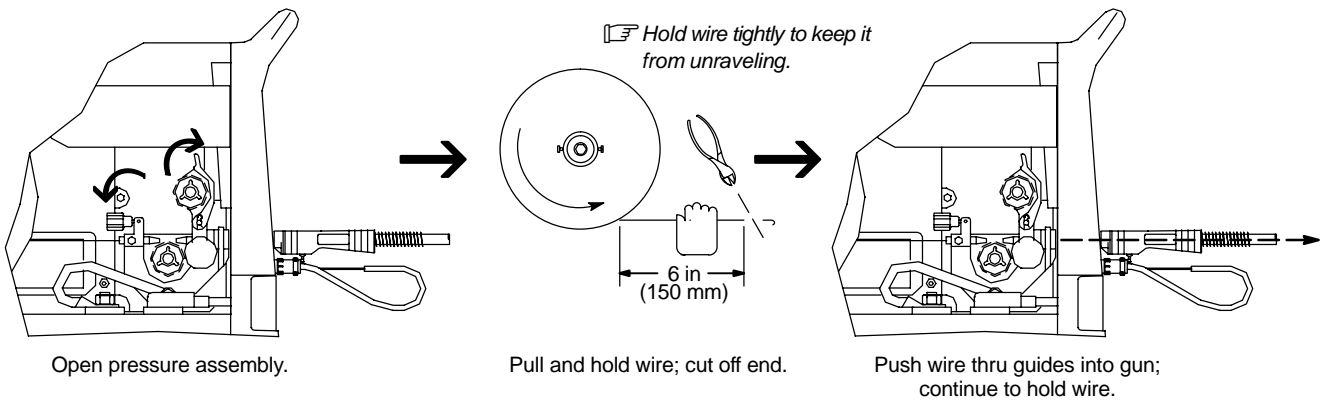
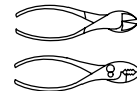

Ref. 802 064-B / S-0627-A

2-15. Using Gun/Cable Holder

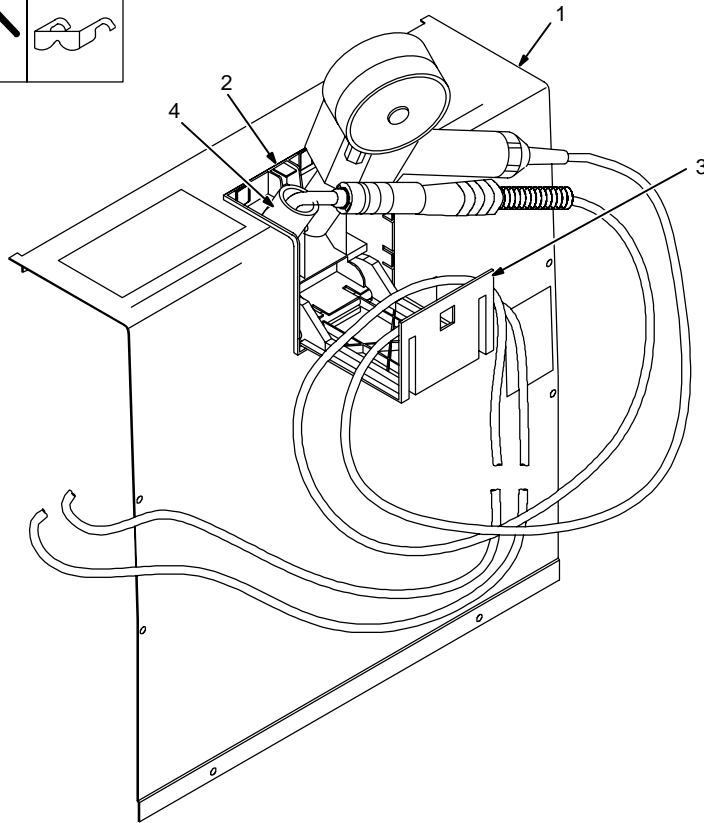

1 Side Panel

2 Latch

3 Cable Holder

Press latch down to release and open door.

4 Holster (2)

Wrap cable around cable holder, and place gun nozzle into holster.

802 726

SECTION 3 – OPERATION

3-1. Controls

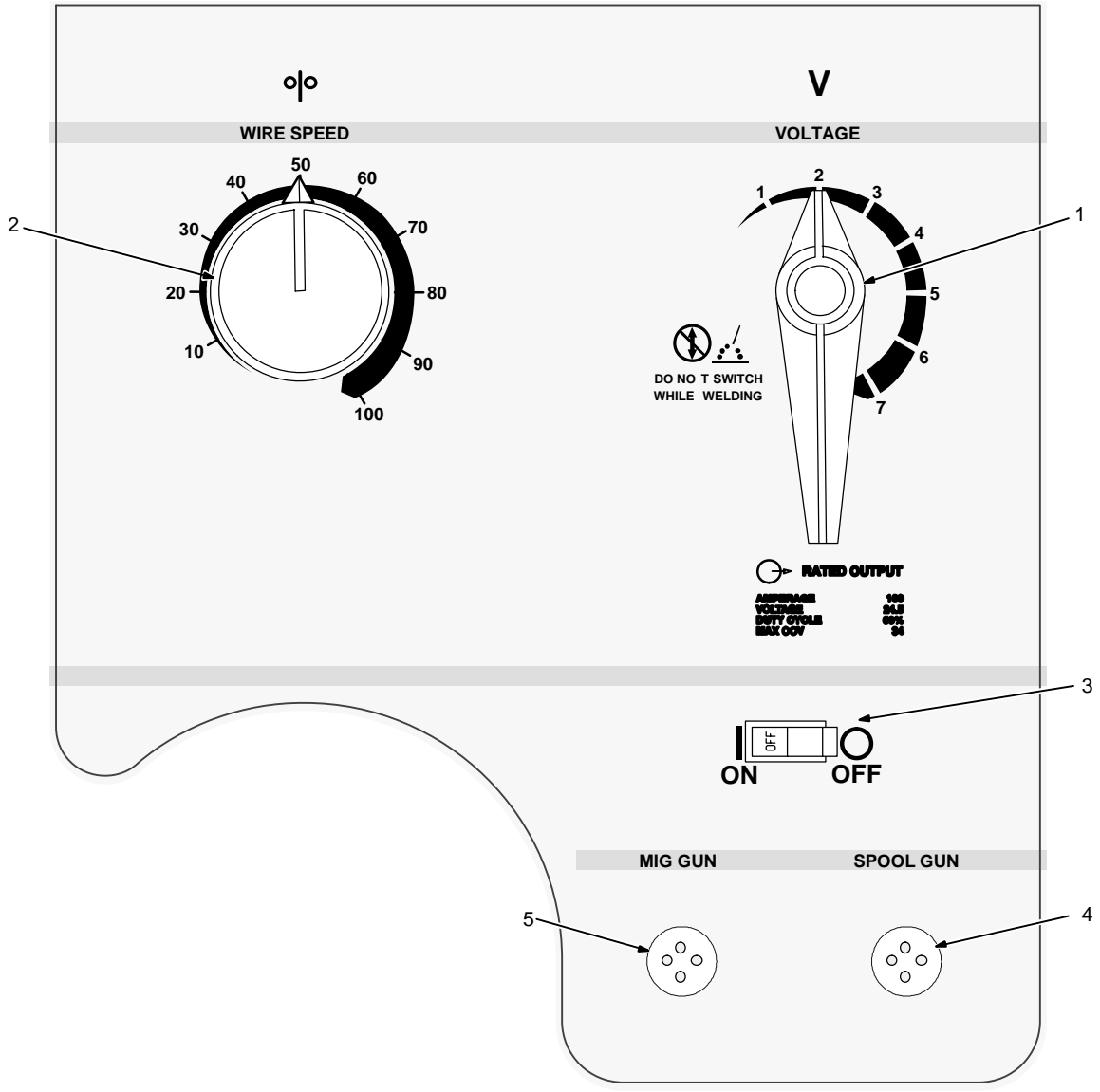
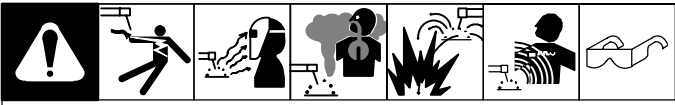

Ref. 200 034-B

1 Voltage Control

Set Voltage control according to the parameter chart for good starting point. Turn control clockwise to increase voltage.

2 Wire Speed Control

Set Wire Speed control according to the parameter chart. Increase or decrease wire speed to obtain desired bead profile and travel speed.

3 Power Switch

This switch energizes the main transformer and control circuitry.

4 Spool Gun Receptacle

5 MIG Gun Receptacle

3-2. Weld Parameter Chart

Selecting Wire, Gas and Control Settings

What Material are You Welding?	Suggested Wire Types	Suggested Shielding Gases and Flow Rate	Wire Sizes (Diameter)
Steel	Solid (or hard) ER70S-6	100% CO ₂ , 25 cfh	0.023" (0.6mm) 0.030" (0.8mm) 0.035" (0.9mm)
		75% Ar/25% CO ₂ , 25 cfh (Ar/CO ₂ produces less spatter - better overall appearance)	0.023" (0.6mm) 0.030" (0.8mm) 0.035" (0.9mm)
Steel – for outdoor, windy applications or when weld appearance is not critical.	Flux core E71T-11	No shielding gas required	0.030" (0.8mm) 0.035" (0.9mm) 0.045" (1.1mm)
Stainless steel	Stainless steel ER 308, ER 308L ER 308LSi	Tri-Mix, 35 cfh (90% He/7.5% Ar/2.5% CO ₂)	0.023" (0.6mm)
			0.030" (0.8mm)
			0.035" (0.9mm)
Aluminum with Spoolmate™ 3035 spoolgun.	Aluminum 4043 ER	100% Ar, 35 cfh	0.030" (0.8mm) 0.035" (0.9mm)

*Line voltage can affect weld output, settings on this chart are starting values only. You may need to adjust voltage and wire feed speed to optimize your settings.

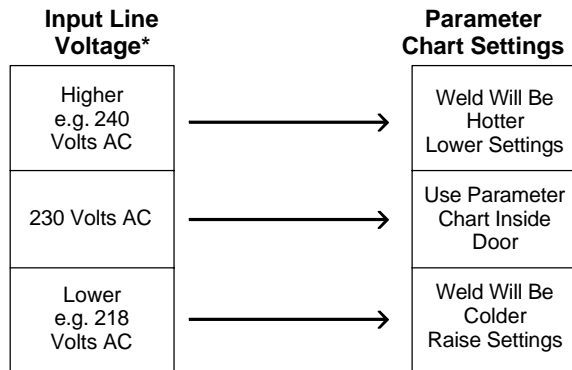

Select Voltage and Wire Speed Based on Thickness of Metal Being Welded

To read settings:

First number is voltage. Second number is wire speed.

(—) Means not recommended.

Wire Speed listed is a starting value only and can be fine-tuned while welding.

Example: 2/40

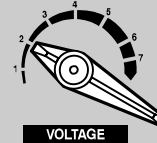

3/8" (9.5 mm)	1/4" (6.4 mm)	3/16" (4.8 mm)	1/8" (3.2 mm)	14 ga. (2.0 mm)	16 ga. (1.6 mm)	18 ga. (1.2 mm)	20 ga. (0.9 mm)	22 ga. (0.8 mm)
—	6/90	5/80	4/60	4/55	3/45	3/40	2/22	2/20
—	6/70	5/60	4/45	3/30	3/28	2/18	2/25	—
6/55	5/48	4/38	4/36	3/25	3/22	2/12	—	—
—	5/90	4/80	3/65	3/60	2/40	2/35	1/22	1/20
5/70	4/60	3/52	3/50	2/34	2/32	2/28	1/18	1/18
5/55	4/48	3/42	3/40	3/35	2/28	2/22	1/12	—
4/65	4/62	3/55	2/42	2/40	1/20	—	—	—
4/52	4/50	3/40	2/32	2/30	1/18	—	—	—
4/32	4/30	3/25	2/20	—	—	—	—	—
7/95	6/90	5/85	5/80	4/75	4/70	3/52	3/52	3/50
7/85	6/80	5/75	5/70	4/60	3/47	3/45	3/40	—
7/70	6/65	5/60	4/50	3/40	3/37	3/35	—	—
—	6/80	5/75	4/70	3/55	—	—	—	—
7/80	6/70	5/65	4/60	3/50	—	—	—	—

SECTION 4 – MAINTENANCE & TROUBLESHOOTING

4-1. Routine Maintenance

				▲ Disconnect power before maintaining.	☞ Maintain more often during severe conditions.
	3 Months				
Replace unreadable labels			Repair or replace cracked weld cable		
Clean and tighten weld terminals					
	6 Months				
Blow out or vacuum inside.		OR		Remove drive roll and carrier. Apply light coat of oil or grease to drive motor shaft.	

Ref. 802 990

4-2. Circuit Breaker CB1

					<p>1 Circuit Breaker CB1 If CB1 opens, wire feeding stops.</p> <p>2 Welding Gun Check gun liner for blockage or kinks.</p> <p>3 Wire Drive Assembly Check for jammed wire, binding drive gear or misaligned drive rolls.</p> <p>Allow cooling period and reset breaker. Close door.</p>

Ref. 802 475-B / Ref. 802 714

4-3. Unit Overload

Thermostats TP1 in rectifier SR1 and TP2 in stabilizer Z1 protect the unit from damage due to overheating. If TP1 and/or TP2 opens, wait several minutes before trying to weld.

4-4. Replacing Gun Contact Tip

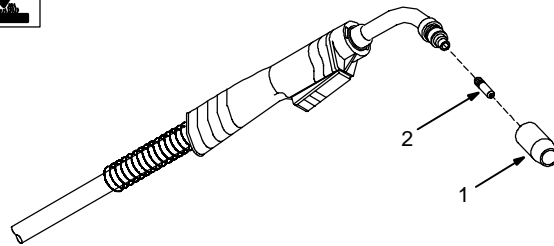

▲ Turn Off power.

- 1 Nozzle
- 2 Contact Tip

Cut off welding wire at contact tip. Remove nozzle.

Remove contact tip and install new contact tip. Reinstall nozzle.

Tools Needed:

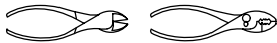

Ref. 800 797-C

4-5. Changing Drive Roll and Wire Inlet Guide

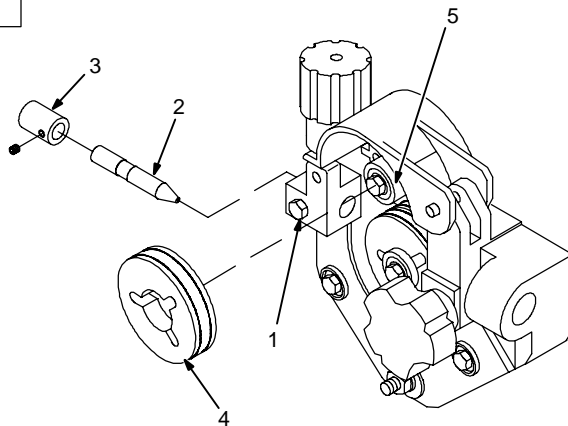

Tools Needed:

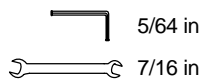

- 1 Securing Screw
- 2 Inlet Wire Guide

Loosen screw. Slide tip as close to drive rolls as possible without touching. Tighten screw.

- 3 Anti-Wear Guide
- Install guide as shown.

- 4 Drive Roll

The drive roll consists of two different sized grooves. The stamped markings on the end surface of the drive roll refers to the groove on the opposite side of the drive roll. The groove closest to the motor shaft is the proper groove to thread (see Section 2-14).

Install correct drive roll for wire size and type.

- 5 Drive Roll Securing Nut

Turn nut one click to secure drive roll.

Ref. 802 990

4-6. Aligning Drive Rolls and Wire Guide

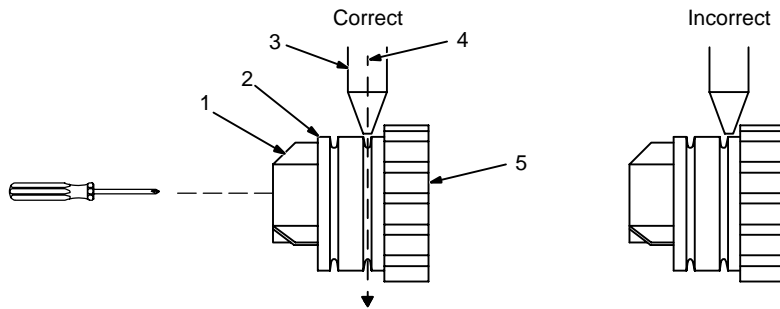
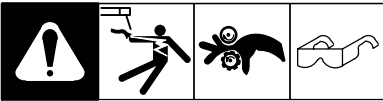

▲ Turn Off power.

View is from top of drive rolls looking down with pressure assembly open.

- 1 Drive Roll Securing Nut
- 2 Drive Roll
- 3 Wire Guide
- 4 Welding Wire
- 5 Drive Gear

Insert screwdriver, and turn screw in or out until drive roll groove lines up with wire guide.

Close pressure roll assembly.

Tools Needed:

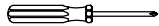

Ref. 800 412-A

4-7. Cleaning Or Replacing Gun Liner

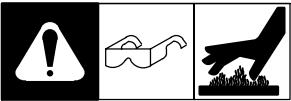

▲ Disconnect gun from unit first.

Tools Needed:

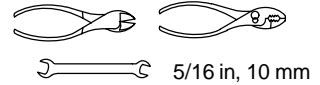

5/16 in, 10 mm

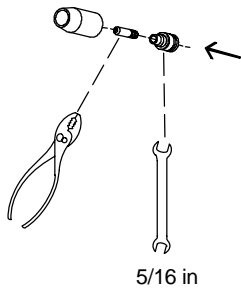

5/16 in

Head Tube

Remove nozzle, contact tip, and adapter.

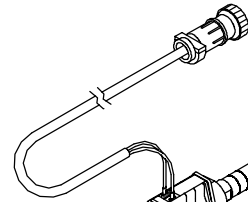

Lay gun cable out straight before installing new liner.

10 mm

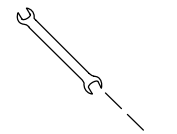

Remove liner.

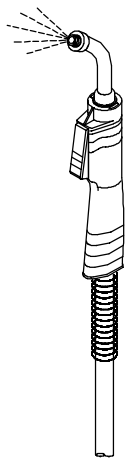
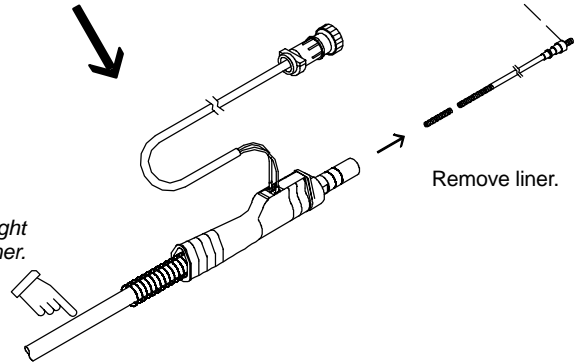

Blow out gun casing.

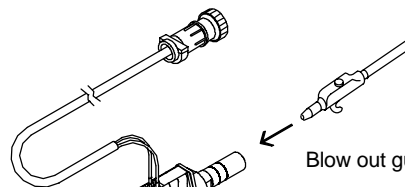

To Reassemble Gun:

Install and tighten new liner.

Cut liner off 3/4 in (20 mm) (3/8 in [9.5 mm] for aluminum) from head tube.

Install adapter, contact tip, and nozzle.

Ref. 800 797-C

4-8. Replacing Switch And/Or Head Tube

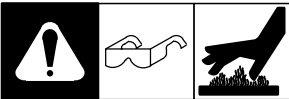

▲ Disconnect gun first.

1 Remove handle locking nut.

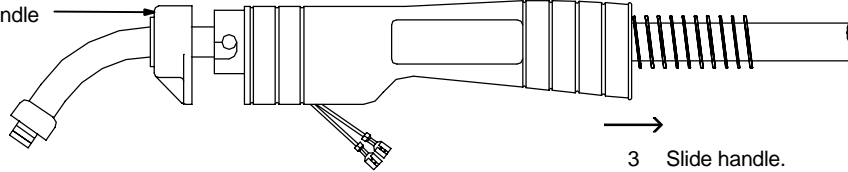

3 Slide handle.

2 Remove switch housing. Note: If installing new switch, push switch lead connectors onto terminal of new switch (polarity is not important). Install switch back into handle, and secure with handle locking nut. If replacing head tube, continue to end of figure.

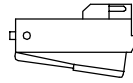

4 Secure head tube in vice.

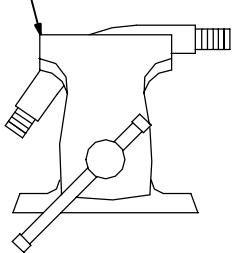

5 Loosen jam nut. Remove from vice and turn head tube out by hand.

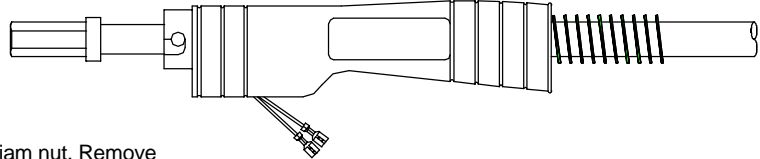
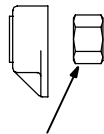

6 Install existing shock washer onto new head tube. Hand-tighten head tube into connector cable.

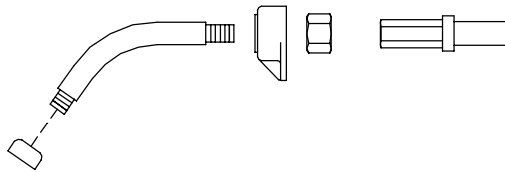

7 Place head tube in vice and tighten until nuts are tight.

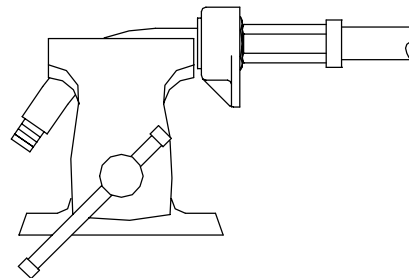

8 Remove from vice. Reposition handle and install switch housing. Secure with handle locking nut.

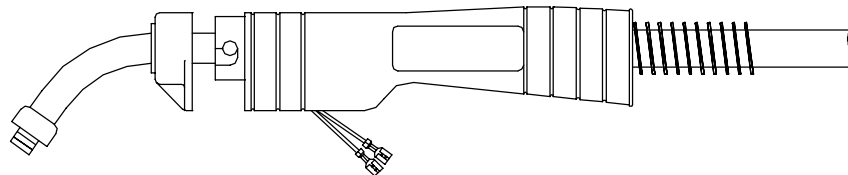

Tools Needed:

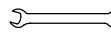
 3/4 in



Ref. 800 795-C

4-9. Troubleshooting

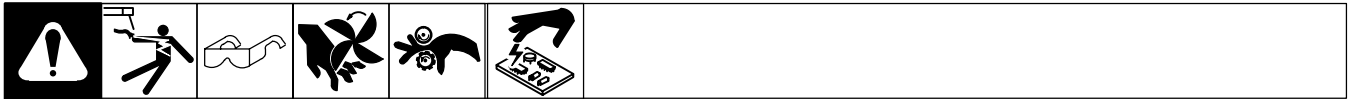

Welding Trouble	Remedy
No weld output; wire does not feed.	Secure power cord plug in receptacle (see Section 2-13).
	Check and replace power switch if necessary.
	Check circuit breaker CB1, and reset if necessary (see Section 4-2).
	Replace building line fuse or reset circuit breaker if open (see Section 2-13).
	Secure gun plug in receptacle or repair leads, or replace trigger switch (see Section 2-6 and/or 4-8).
	Thermostat TP1 or TP2 open (overheating). Allow fan to run; the thermostat will close when the unit has cooled (see Section 4-3).
No weld output; wire feeds.	Connect work clamp to get good metal to metal contact.
	Replace contact tip (see Section 4-4).
Low weld output.	Connect unit to proper input voltage or check for low line voltage (see Section 2-13).
Low, high, or erratic wire speed.	Readjust front panel settings (see Section 3-1).
	Change to correct size drive roll (see Section 4-5).
	Readjust drive roll pressure (see Section 2-14).
	Replace inlet guide, contact tip, and/or liner if necessary (see Sections 4-4, and 4-7).
Wire Drive/Gun Trouble	Remedy
Electrode wire feeding stops during welding.	Straighten gun cable and/or replace damaged parts (see Section 4-7).
	Adjust drive roll pressure (see Section 2-14).
	Readjust hub tension (see Section 2-10).
	Replace contact tip if blocked (see Section 4-4).
	Clean or replace wire inlet guide or liner if dirty or plugged (see Section 4-7).
	Replace drive roll if worn or slipping (see Section 4-5).
	Secure gun plug in receptacle or repair leads, or replace trigger switch (see Section 2-6 and/or 4-8).
	Check and clear any restrictions at drive assembly and liner (see Section 4-7).
Have nearest Factory Authorized Service Agent check drive motor.	

SECTION 5 – ELECTRICAL DIAGRAM

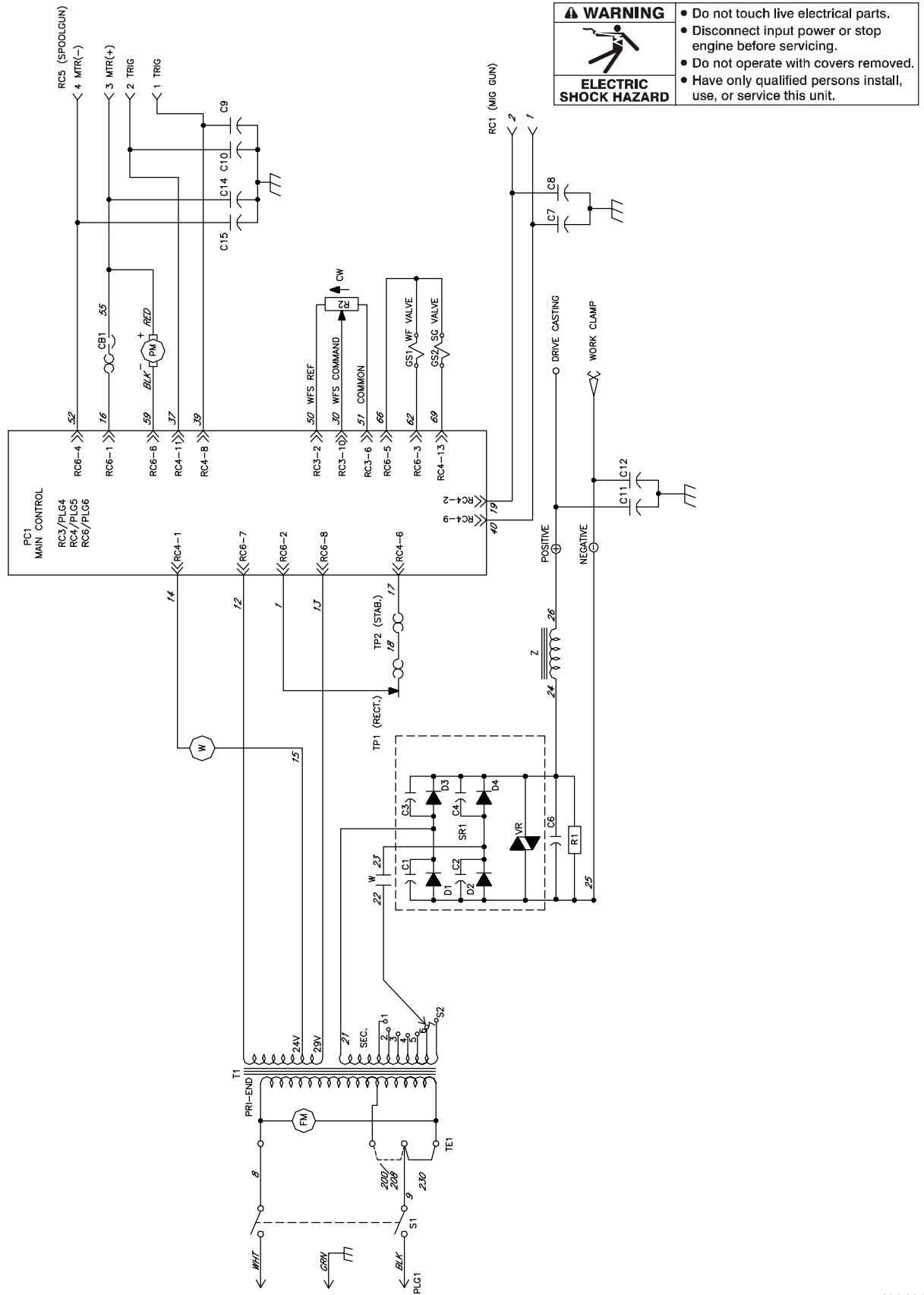
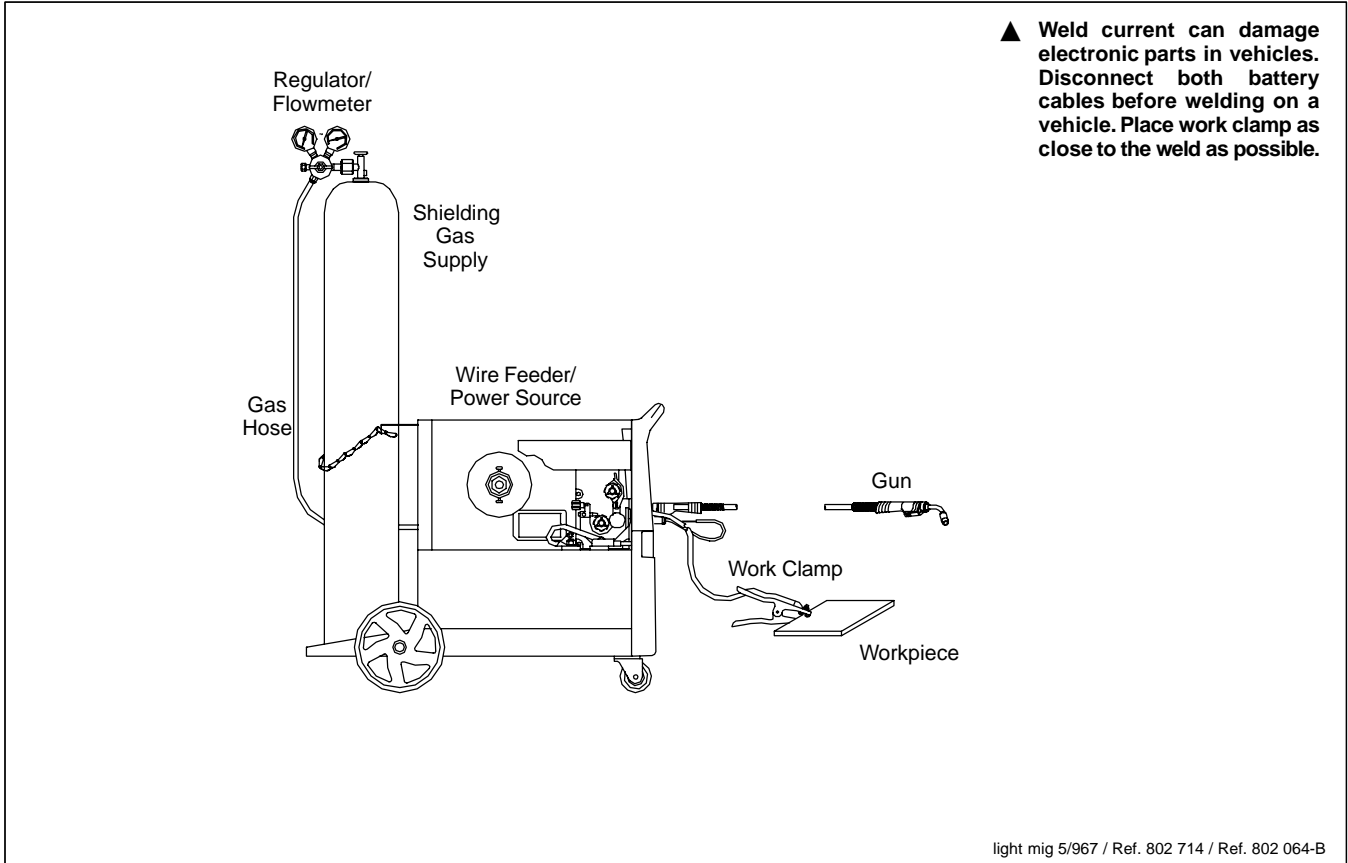

Figure 5-1. Welding Power Source Circuit Diagram

SECTION 6 – MIG WELDING (GMAW) GUIDELINES



6-1. Typical MIG Process Connections



6-2. Typical MIG Process Control Settings

NOTE

These settings are guidelines only. Material and wire type, joint design, fitup, position, shielding gas, etc. affect settings. Test welds to be sure they comply to specifications.

Material thickness determines weld parameters.

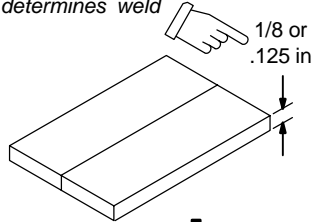

Convert Material Thickness to Amperage (A)

(.001 in = 1 ampere)

.125 in = 125 A

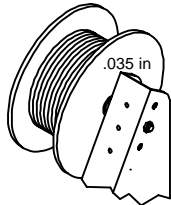

Wire Size	Amperage Range
.023 in	30 – 90 A
.030 in	40 – 145 A
.035 in	50 – 180 A

Select Wire Size

Wire Size	Recommendation	Wire Speed (Approx.)
.023 in	3.5 in per ampere	3.5 x 125 A = 437 ipm
.030 in	2 in per ampere	2 x 125 A = 250 ipm
.035 in	1.6 in per ampere	1.6 x 125 A = 200 ipm

Select Wire Speed (Amperage)

125 A based on 1/8 in material thickness

ipm = inch per minute

Low voltage: wire stubs into work
 High voltage: arc is unstable (spatter)
 Set voltage midway between high/low voltage.

Select Voltage

Wire speed (amperage) controls weld penetration
 (wire speed = burn-off rate)

Voltage controls height and width of weld bead.

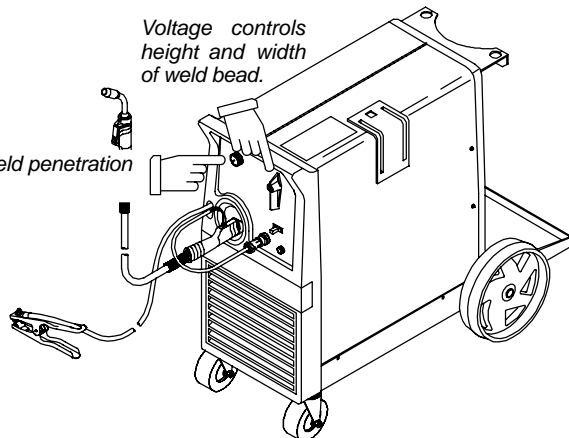

802 992

6-3. Holding And Positioning Welding Gun

NOTE 

Welding wire is energized when gun trigger is pressed. Before lowering helmet and pressing trigger, be sure wire is no more than 1/2 in (13 mm) past end of nozzle, and tip of wire is positioned correctly on seam.

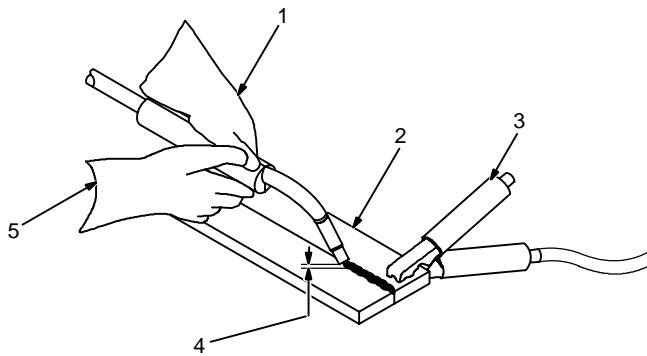

- 1 Hold Gun and Control Gun Trigger
- 2 Workpiece
- 3 Work Clamp
- 4 Electrode Extension (Stickout) 1/4 to 1/2 in (6 To 13 mm)
- 5 Cradle Gun and Rest Hand on Workpiece

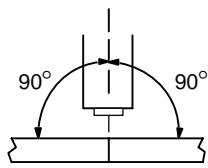

End View Of Work Angle

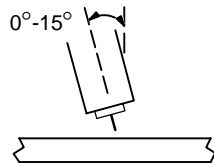

Side View Of Gun Angle

GROOVE WELDS

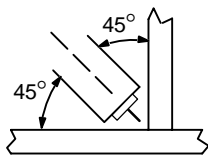

End View Of Work Angle

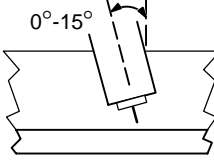

Side View Of Gun Angle

FILLET WELDS

S-0421-A

6-4. Conditions That Affect Weld Bead Shape

NOTE

Weld bead shape depends on gun angle, direction of travel, electrode extension (stickout), travel speed, thickness of base metal, wire feed speed (weld current), and voltage.

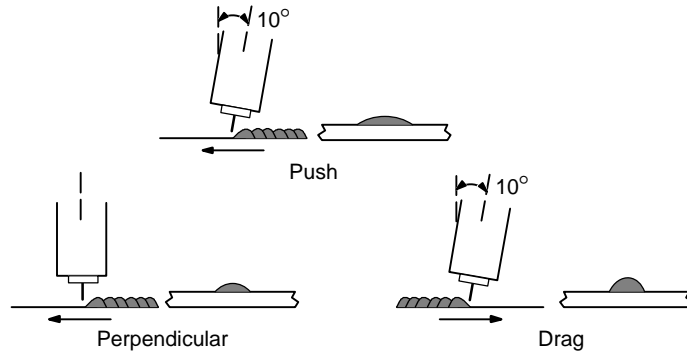

GUN ANGLES AND WELD BEAD PROFILES

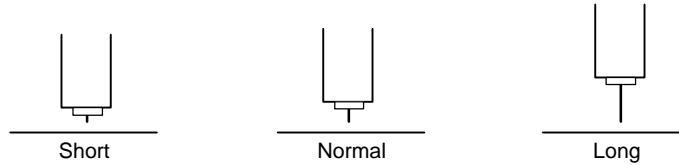

ELECTRODE EXTENSIONS (STICKOUT)

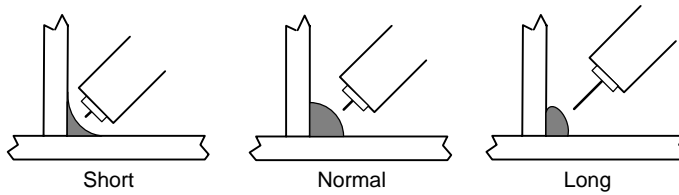

FILLET WELD ELECTRODE EXTENSIONS (STICKOUT)

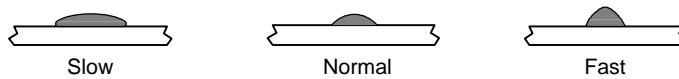

GUN TRAVEL SPEED

S-0634

6-5. Gun Movement During Welding

NOTE

Normally, a single stringer bead is satisfactory for most narrow groove weld joints; however, for wide groove weld joints or bridging across gaps, a weave bead or multiple stringer beads works better.

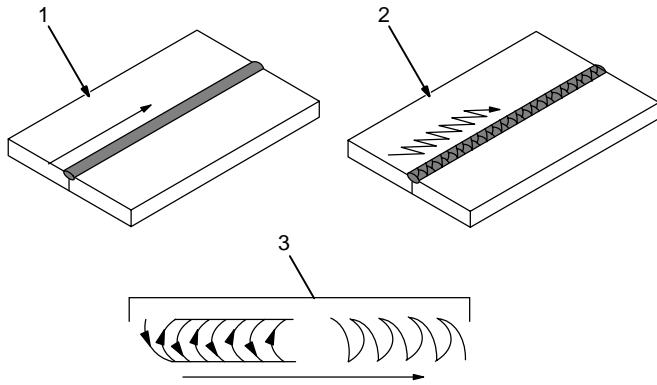

- 1 Stringer Bead – Steady Movement Along Seam
- 2 Weave Bead – Side To Side Movement Along Seam
- 3 Weave Patterns

Use weave patterns to cover a wide area in one pass of the electrode.

S-0054-A

6-6. Poor Weld Bead Characteristics

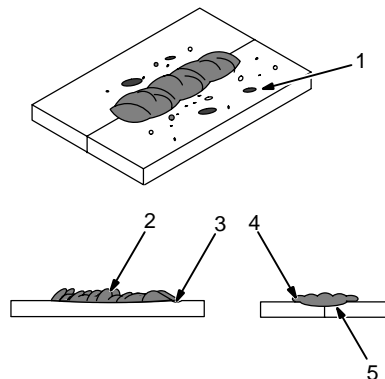

- 1 Large Spatter Deposits
- 2 Rough, Uneven Bead
- 3 Slight Crater During Welding
- 4 Bad Overlap
- 5 Poor Penetration

S-0053-A

6-7. Good Weld Bead Characteristics

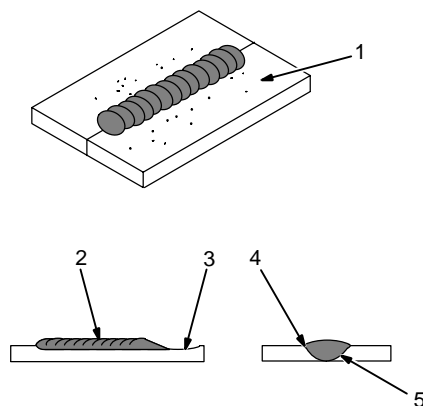

- 1 Fine Spatter
- 2 Uniform Bead
- 3 Moderate Crater During Welding

Weld a new bead or layer for each 1/8 in (3.2 mm) thickness in metals being welded.

- 4 No Overlap
- 5 Good Penetration into Base Metal

S-0052-B

6-8. Troubleshooting – Excessive Spatter

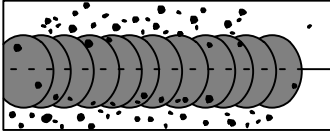

Excessive Spatter – scattering of molten metal particles that cool to solid form near weld bead.

S-0636

Possible Causes	Corrective Actions
Wire feed speed too high.	Select lower wire feed speed.
Voltage too high.	Select lower voltage range.
Electrode extension (stickout) too long.	Use shorter electrode extension (stickout).
Workpiece dirty.	Remove all grease, oil, moisture, rust, paint, undercoating, and dirt from work surface before welding.
Insufficient shielding gas at welding arc.	Increase flow of shielding gas at regulator/flowmeter and/or prevent drafts near welding arc.
Dirty welding wire.	Use clean, dry welding wire.
	Eliminate pickup of oil or lubricant on welding wire from feeder or liner.

6-9. Troubleshooting – Porosity

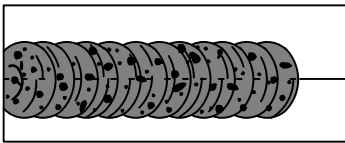

Porosity – small cavities or holes resulting from gas pockets in weld metal.

S-0635

Possible Causes	Corrective Actions
Insufficient shielding gas at welding arc.	Increase flow of shielding gas at regulator/flowmeter and/or prevent drafts near welding arc.
	Remove spatter from gun nozzle.
	Check gas hoses for leaks.
	Place nozzle 1/4 to 1/2 in (6-13 mm) from workpiece.
	Hold gun near bead at end of weld until molten metal solidifies.
Wrong gas.	Use welding grade shielding gas; change to different gas.
Dirty welding wire.	Use clean, dry welding wire.
	Eliminate pick up of oil or lubricant on welding wire from feeder or liner.
Workpiece dirty.	Remove all grease, oil, moisture, rust, paint, coatings, and dirt from work surface before welding.
	Use a more highly deoxidizing welding wire (contact supplier).
Welding wire extends too far out of nozzle.	Be sure welding wire extends not more than 1/2 in (13 mm) beyond nozzle.

6-10. Troubleshooting – Excessive Penetration

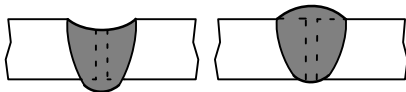

Excessive Penetration Good Penetration

Excessive Penetration – weld metal melting through base metal and hanging underneath weld.

S-0639

Possible Causes	Corrective Actions
Excessive heat input.	Select lower voltage range and reduce wire feed speed.
	Increase travel speed.

6-11. Troubleshooting – Lack Of Penetration

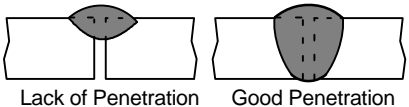
		<p>Lack Of Penetration – shallow fusion between weld metal and base metal.</p>	S-0638
Possible Causes	Corrective Actions		
Improper joint preparation.	Material too thick. Joint preparation and design must provide access to bottom of groove while maintaining proper welding wire extension and arc characteristics.		
Improper weld technique.	Maintain normal gun angle of 0 to 15 degrees to achieve maximum penetration.		
	Keep arc on leading edge of weld puddle.		
	Be sure welding wire extends not more than 1/2 in (13 mm) beyond nozzle.		
Insufficient heat input.	Select higher wire feed speed and/or select higher voltage range.		
	Reduce travel speed.		

6-12. Troubleshooting – Incomplete Fusion

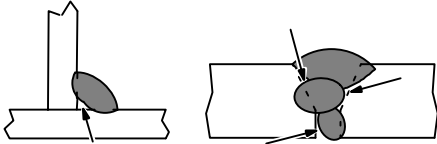
		<p>Incomplete Fusion – failure of weld metal to fuse completely with base metal or a preceding weld bead.</p>	S-0637
Possible Causes	Corrective Actions		
Workpiece dirty.	Remove all grease, oil, moisture, rust, paint, undercoating, and dirt from work surface before welding.		
Insufficient heat input.	Select higher voltage range and/or adjust wire feed speed.		
Improper welding technique.	Place stringer bead in proper location(s) at joint during welding.		
	Adjust work angle or widen groove to access bottom during welding.		
	Momentarily hold arc on groove side walls when using weaving technique.		
	Keep arc on leading edge of weld puddle.		
	Use correct gun angle of 0 to 15 degrees.		

6-13. Troubleshooting – Burn-Through

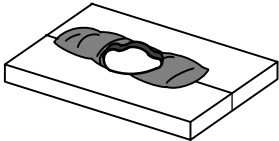
		<p>Burn-Through – weld metal melting completely through base metal resulting in holes where no metal remains.</p>	S-0640
Possible Causes	Corrective Actions		
Excessive heat input.	Select lower voltage range and reduce wire feed speed.		
	Increase and/or maintain steady travel speed.		

6-14. Troubleshooting – Waviness Of Bead

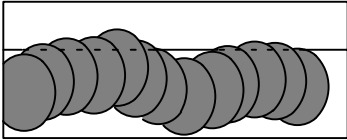
		<p>Waviness Of Bead – weld metal that is not parallel and does not cover joint formed by base metal.</p>	S-0641
Possible Causes		Corrective Actions	
Welding wire extends too far out of nozzle.		Be sure welding wire extends not more than 1/2 in (13 mm) beyond nozzle.	
Unsteady hand.		Support hand on solid surface or use two hands.	

6-15. Troubleshooting – Distortion

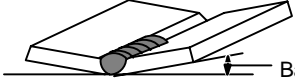
		<p>Distortion – contraction of weld metal during welding that forces base metal to move.</p>	S-0642
<p>Base metal moves in the direction of the weld bead.</p>			
Possible Causes		Corrective Actions	
Excessive heat input.		Use restraint (clamp) to hold base metal in position.	
		Make tack welds along joint before starting welding operation.	
		Select lower voltage range and/or reduce wire feed speed.	
		Increase travel speed.	
		Weld in small segments and allow cooling between welds.	

6-16. Common MIG Shielding Gases

This is a general chart for common gases and where they are used. Many different combinations (mixtures) of shielding gases have been developed over the years. The most commonly used shielding gases are listed in the following table.

Gas	Application			
	Spray Arc Steel	Short Circuiting Steel	Short Circuiting Stainless Steel	Aluminum
Argon				X
Argon + 25% CO ₂		X		
80% or greater Argon + balance CO ₂ or Oxygen	X	X ¹		
100% CO ₂		X	X	
Tri-Mix ²			X	

1 Limited short circuiting use

2 90% HE + 7-1/2% AR + 2-1/2% CO₂

6-17. Troubleshooting Guide For Semiautomatic Welding Equipment

Problem	Probable Cause	Remedy
Wire feed motor operates, but wire does not feed.	Too little pressure on wire feed rolls.	Increase pressure setting on wire feed rolls.
	Incorrect wire feed rolls.	Check size stamped on wire feed rolls, replace to match wire size and type if necessary.
	Wire spool brake pressure too high.	Decrease brake pressure on wire spool.
	Restriction in the gun and/or assembly.	Check and replace cable, gun, and contact tip if damaged. Check size of contact tip and cable liner, replace if necessary.
Wire curling up in front of the wire feed rolls (bird nesting).	Too much pressure on wire feed rolls.	Decrease pressure setting on wire feed rolls.
	Incorrect cable liner or gun contact tip size.	Check size of contact tip and check cable liner length and diameter, replace if necessary.
	Gun end not inserted into drive housing properly.	Loosen gun securing bolt in drive housing and push gun end into housing just enough so it does not touch wire feed rolls.
	Dirty or damaged (kinked) liner.	Replace liner.
Wire feeds, but no gas flows.	Gas cylinder empty.	Replace empty gas cylinder.
	Gas nozzle plugged.	Clean or replace gas nozzle.
	Gas cylinder valve not open or flowmeter not adjusted.	Open gas valve at cylinder and adjust flow rate.
	Restriction in gas line.	Check gas hose between flowmeter and wire feeder, and gas hose in gun and cable assembly.
	Loose or broken wires to gas solenoid.	Have Factory Authorized Service Agent repair wiring.
	Gas solenoid valve not operating.	Have Factory Authorized Service Agent replace gas solenoid valve.
	Incorrect primary voltage connected to welding power source.	Check primary voltage and relink welding power source for correct voltage.

Problem	Probable Cause	Remedy
Welding arc not stable.	Wire slipping in drive rolls.	Adjust pressure setting on wire feed rolls. Replace worn drive rolls if necessary.
	Wrong size gun liner or contact tip.	Match liner and contact tip to wire size and type.
	Incorrect voltage setting for selected wire feed speed on welding power source.	Readjust welding parameters.
	Loose connections at the gun weld cable or work cable.	Check and tighten all connections.
	Gun in poor shape or loose connection inside gun.	Repair or replace gun as necessary.

SECTION 7 – PARTS LIST

 Hardware is common and not available unless listed.

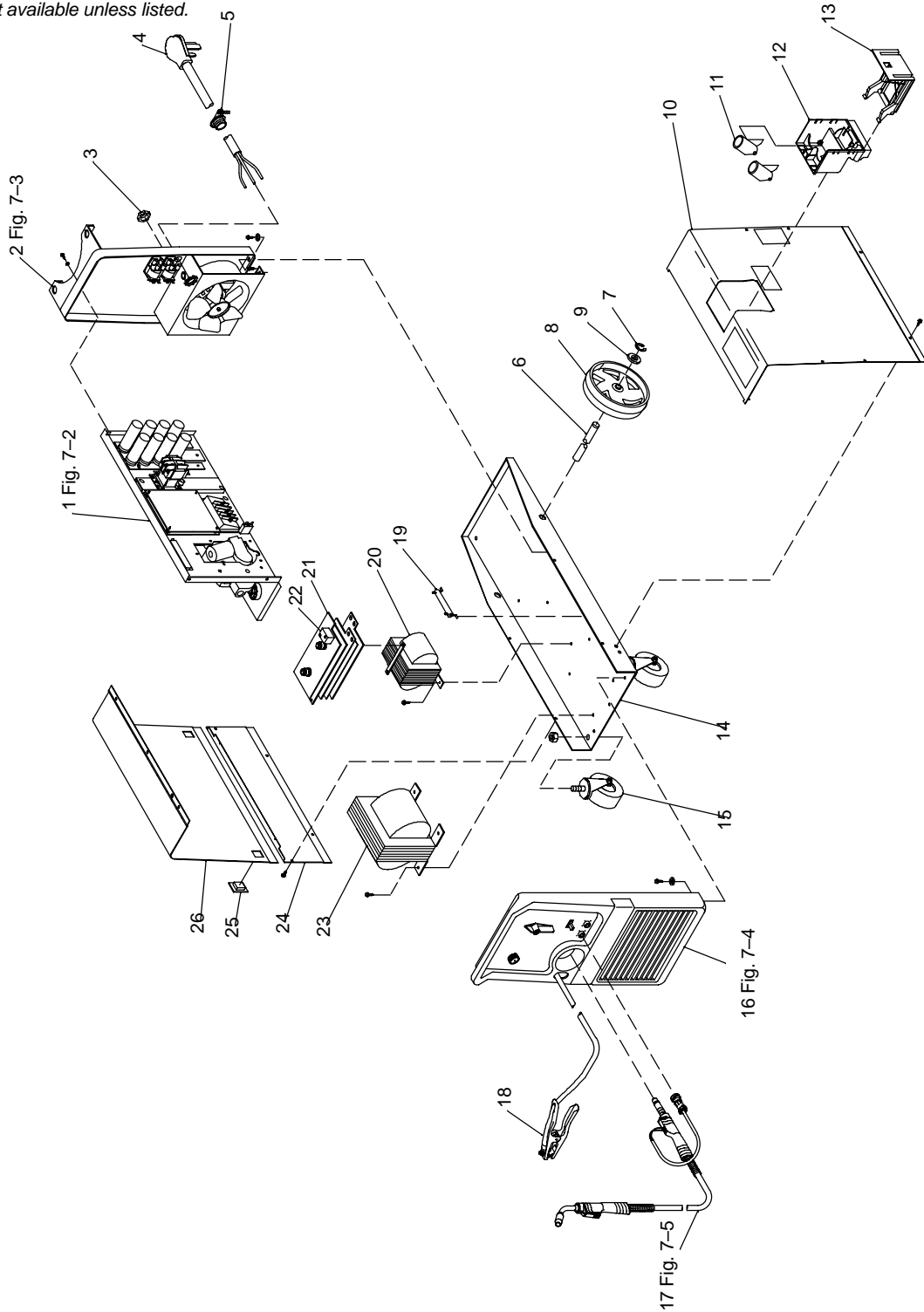

Figure 7-1. Main Assembly

802 993

Item No.	Dia. Mkgs.	Part No.	Description	Quantity
----------	------------	----------	-------------	----------

Figure 7-1. Main Assembly

1		Figure 7-2	BAFFLE,CENTER	1
2		Figure 7-3	PANEL,REAR	1
3		605227	NUT, 750-14 KNURLED1.68DIA .41H NYL	2
4		199192	CORD SET,250V 6-50P 12GA 3/C 9FT ST JKT	1
5		604102	CONN,CLAMP CABLE 1.000	1
6		052692	AXLE,RUNNING GEAR .750 DIA X 25.745 (consisting of)	1
7		121614	RING,RTNG EXT .750 SHAFT X .085 THK E STYLE	2
8		186758	WHEEL	2
9		602250	WASHER,FLAT STL SAE .750	2
10		203482	+WRAPPER,	1
		134464	LABEL,WARNING GENERAL PRECAUTIONARY STATIC&WIRE FE	1
		193328	LABEL,WARNING ELECTRIC SHOCK AND INCORRECT INPUT P	1
		201019	LABEL,WARNING ELECTRIC SHOCK EXCESS WEIGHT	1
		200923	GUN/CABLE HOLDER,(CONSISTING OF)	1
11		200921	HOLSTER,GUN/CABLE HOLDER	2
12		200922	HOUSING,GUN/CABLE HOLDER	1
13		200920	DOOR,GUN/CABLE HOLDER	1
14		146161	BASE,	1
15		008999	CASTER,SWVL 4.00 IN POLY-OLEFIN	2
16		Figure 7-4	PANEL,FRONT	1
17		Figure 7-5	M-25 GUN 12 FT .030-.035	1
18		196328	CABLE,WORK 10' NO 3 W/CLAMP (CONSISTING OF)	1
		130750	CLAMP,WORK 300 AMP	1
		600318	CABLE,WELD COP STRD NO 3 EPDM JKT (ORDER BY FT)	10FT
		196318	COVER,CABLE BTRY POST BLK .75 ID	1
19		091685	RESISTOR,WW FXD 50 W 25 OHM FASTON TE	1
20		*204879	STABILIZER (CONSISTING OF)	1
	TP2	163266	THERMOSTAT,NC OPEN 150C W/INSULATOR LEADS W/TERMS	1
21		192428	RECTIFIER,SI 1PH 300 AMP 200 PIV 60% (CONSISTING OF)	1
22	TP1	604515	THERMOSTAT,NC OPEN 211° F CLOSE 186° F FLANGE FASTON	1
23		205601	XFMR,POWER MAIN 200(208)/230	1
24		203481	PANEL,SIDE LH	1
25		151187	LATCH,SLIDE FLUSH STYLE SERIES 40	2
26		203480	DOOR,HINGED	1
		204890	LABEL,PARAMETER	1

+When ordering a component originally displaying a precautionary label, the label should also be ordered.

*When ordering stabilizer 204 879, also order thermostat 163 266.

To maintain the factory original performance of your equipment, use only Manufacturer's Suggested Replacement Parts. Model and serial number required when ordering parts from your local distributor.

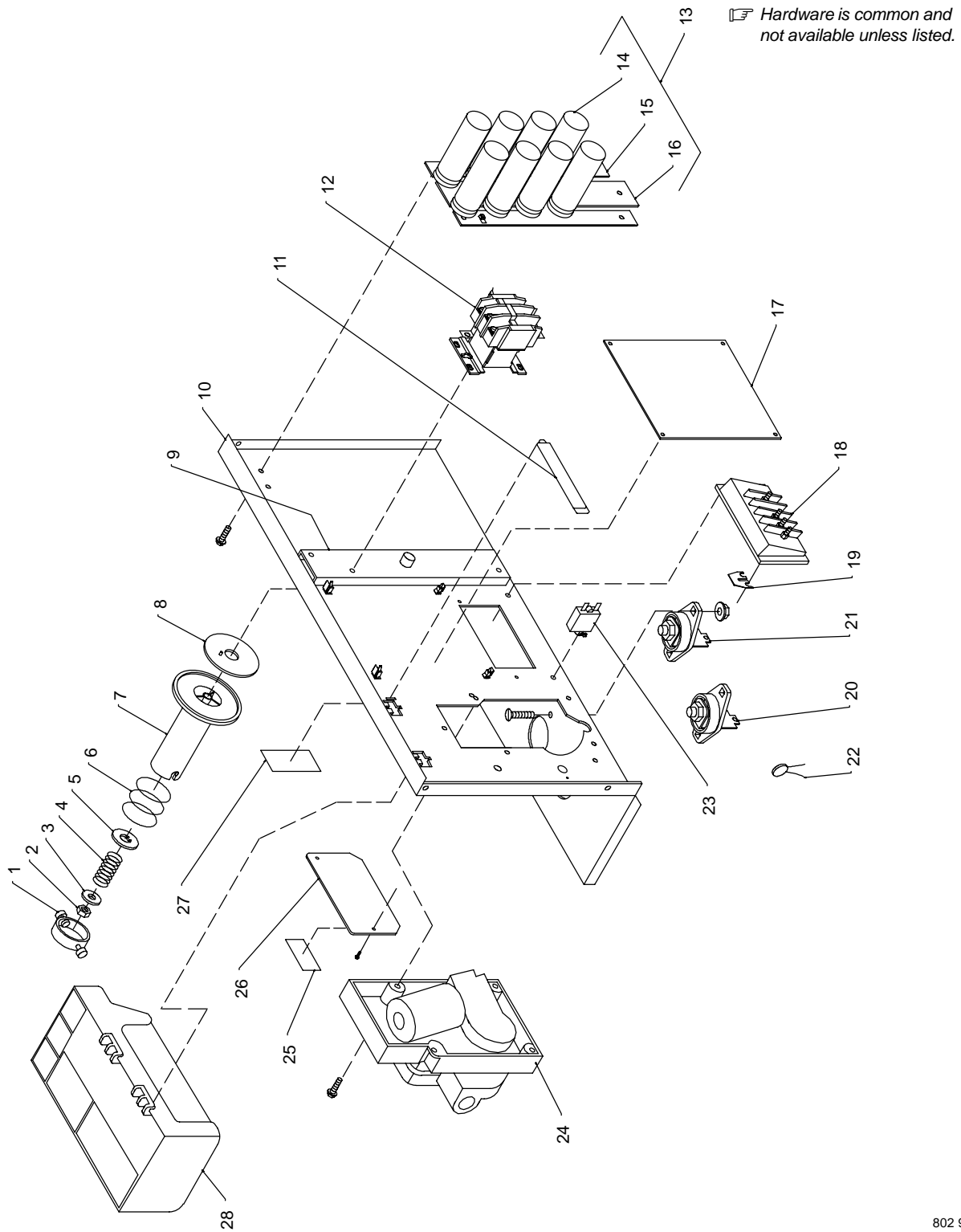

Figure 7-2. Baffle, Center w/Components

802 989

Item No.	Dia. Mkgs.	Part No.	Description	Quantity
Figure 7-2. Baffle, Center w/Components (Figure 7-1 Item 1)				
.....		196001	.. SPOOL HUB ASSEMBLY,(CONSISTING OF)	1
1		058427	.. RING,RETAINING SPOOL	1
2		085980	.. NUT,STL HEX FULL .625-11	1
3		605941	.. WASHER,FLAT STL .640 ID X 1.000 OD X 14GA THK	1
4		186437	.. SPRING,CPRSN .845 OD X .110 WIRE X 1.500	1
5		057971	.. WASHER,FLAT STL KEYED 1.500DIA X .125THK	1
6		057745	.. SPRING,CPRSN 2.430 OD X .090 WIRE X 2.500	1
7		186435	.. HUB,SPOOL	1
8		186436	.. WASHER,BRAKE PLASTIC	1
9		177307	.. REEL SUPPORT	1
10		+204856	.. BAFFLE,CENTER	1
11		196894	.. BRACKET,CONSUMABLE/TOOL TRAY	1
12		189486	.. CONTACTOR,DEF PRP 40A 3P 24VAC COIL W/LINKS	1
.....		034260	.. LINK,CONNECTING CONTACTOR TERMINAL	2
13	C6	185644	.. CAPACITOR ASSY,(CONSISTING OF)	1
14		184584	.. CAPACITOR,ELCTLT 15000UF 45VDC	8
15		185643	.. BUSS BAR,CAPACITOR	2
16		082902	.. STRIP,MTG CENTER CAPACITOR	1
.....		083147	.. GROMMET,SCR NO. 8/10 PANEL HOLE .312SQ .500 HIGH	6
.....		187752	.. STRIP,INSULATOR CAPACITOR	1
17	PC1	204 807	.. CIRCUIT CARD ASSY,CONTROL	1
.....	PLG4	131056	.. HOUSING RECEPTACLE & SOCKETS	1
.....	PLG6	115092	.. HOUSING PLUG & SOCKETS	1
.....		134201	.. STAND-OFF SUPPORT,PC CARD .312/.375W/POST&LOCK .43	4
18	TE1	188910	.. TERM ASSY,PRI 1PH 2V	1
.....		153980	.. LABEL,LINK	1
19		038618	.. LINK,JUMPER TERM BD PRI	as req.
20		097416	.. TERMINAL,PWR OUTPUT BLACK	1
21		097421	.. TERMINAL,PWR OUTPUT RED	1
22	C11,12	128750	.. CAPACITOR,CER DISC .1 UF 500 VDC W/TERMS	2
23	CB1	180912	.. CIRCUIT BREAKER,MAN RESET 1P 5A 250VAC	1
24	Figure 7-6		.. DRIVE ASSY,WIRE	1
25		021469	.. LABEL,WARNING HIGH VOLTAGE	1
26		+188917	.. DOOR,ACCESS CHANGEOVER	1
27		199824	.. LABEL,WARNING ELECTRIC SHOCK AND PINCH POINTS	1
28		197555	.. TRAY,CONSUMABLE/TOOL W/BUMPER	1
.....		172171	.. FTG,HOSE BRS BARBED COUPLER	1
.....		010493	.. BUSHING,SNAP-IN NYL .625 ID X .875 MTG HOLE	1

+When ordering a component originally displaying a precautionary label, the label should also be ordered.

To maintain the factory original performance of your equipment, use only Manufacturer's Suggested Replacement Parts. Model and serial number required when ordering parts from your local distributor.

☞ Hardware is common and not available unless listed.

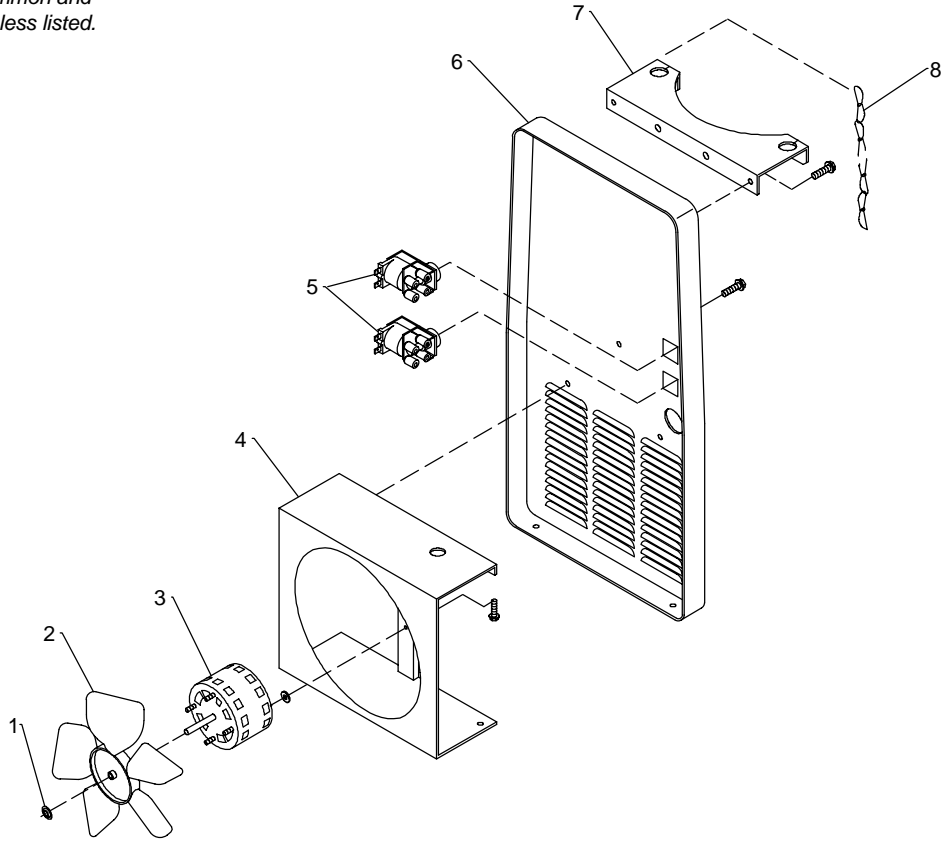

802 988

Figure 7-3. Panel, Rear w/Components

Item No.	Dia. Mkgs.	Part No.	Description	Quantity
----------	------------	----------	-------------	----------

Figure 7-3. Panel, Rear w/Components (Figure 7-1 Item 2)

... 1	...	049399	.. NUT, 312-18 PUSH ON .63D .07H STL	1
... 2	...	148809	.. BLADE,FAN 9.000 5WG 34DEG .312 BORE CCW PLSTC	1
... 3	...	188706	.. MOTOR,FAN 230V 50/60HZ 1550 RPM .312 DIA SHAFT	1
... 4	...	203711	.. WINDTUNNEL,9.000	1
... 5	...	200333	.. VALVE, 34VDC 2WAY CUSTOM PORT 1/8 ORF W/FRICT	2
... 6	...	204770	.. PANEL,REAR	1
...	...	201022	.. LABEL,GAS IN SPOOLGUN/MIG GUN	1
... 7	...	+169654	.. BRACKET,SUPPORT CYL CRM	1
...	...	200285	.. LABEL,WARNING CYLINDER MAY EXPLODE IF DAMAGED	1
... 8	...	188441	.. CHAIN,WELDLESS 2/0 X 31 LG	2

☞ Hardware is common and not available unless listed.

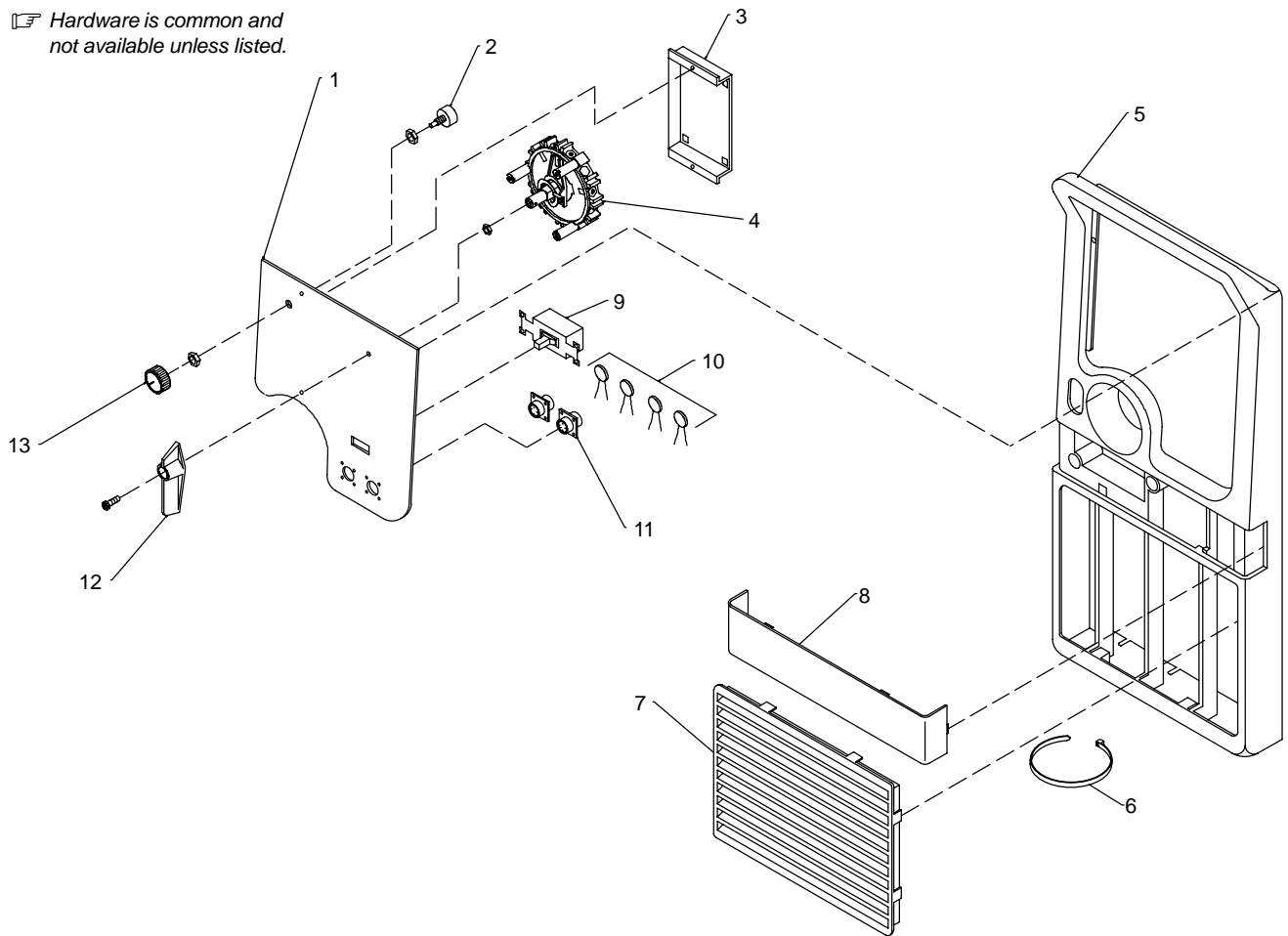

802 987

Figure 7-4. Panel, Front w/Components

Item No.	Dia. Mkgs.	Part No.	Description	Quantity
----------	------------	----------	-------------	----------

Figure 7-4. Panel, Front w/Components (Figure 7-1 Item 16)

...	1	204845	.. PANEL,FRONT CONTROL	1
...		204843	.. LABEL,NAMEPLATE MILLERMATIC 210	1
...	2	198087	.. POT,CP STD SLOT 1T 2. W 1K LINEAR	1
...	3	196801	.. BRACKET,MTG	1
...	4	S2 192373	.. SWITCH,SELECTOR 7 POSITION	1
...	5	186473	.. PANEL,FRONT	1
...	6	174422	.. CABLE TIE, 0-1.875 BUNDLE PLT2S-M0 BLACK	1
...	7	186472	.. PANEL,LOUVER	1
...	8	186470	.. PANEL,LOGO	1
...	9	S1 124511	.. SWITCH,TGL DPST 40A 600VAC SCR TERM WIDE TGL	1
...	10	C7,8,9,10, 14,15 136735	.. CAPACITOR,CER DISC .1UF 500VDC STRIP	6
...	11	048282	.. RECEPTACLE W/SOCKETS	2
...	12	148956	.. HANDLE,SWITCH	1
...	13	097924	.. KNOB,POINTER 1.625 DIA X .250 ID W/SET SCREWSPLSTC	1

+When ordering a component originally displaying a precautionary label, the label should also be ordered.

To maintain the factory original performance of your equipment, use only Manufacturer's Suggested Replacement Parts. Model and serial number required when ordering parts from your local distributor.

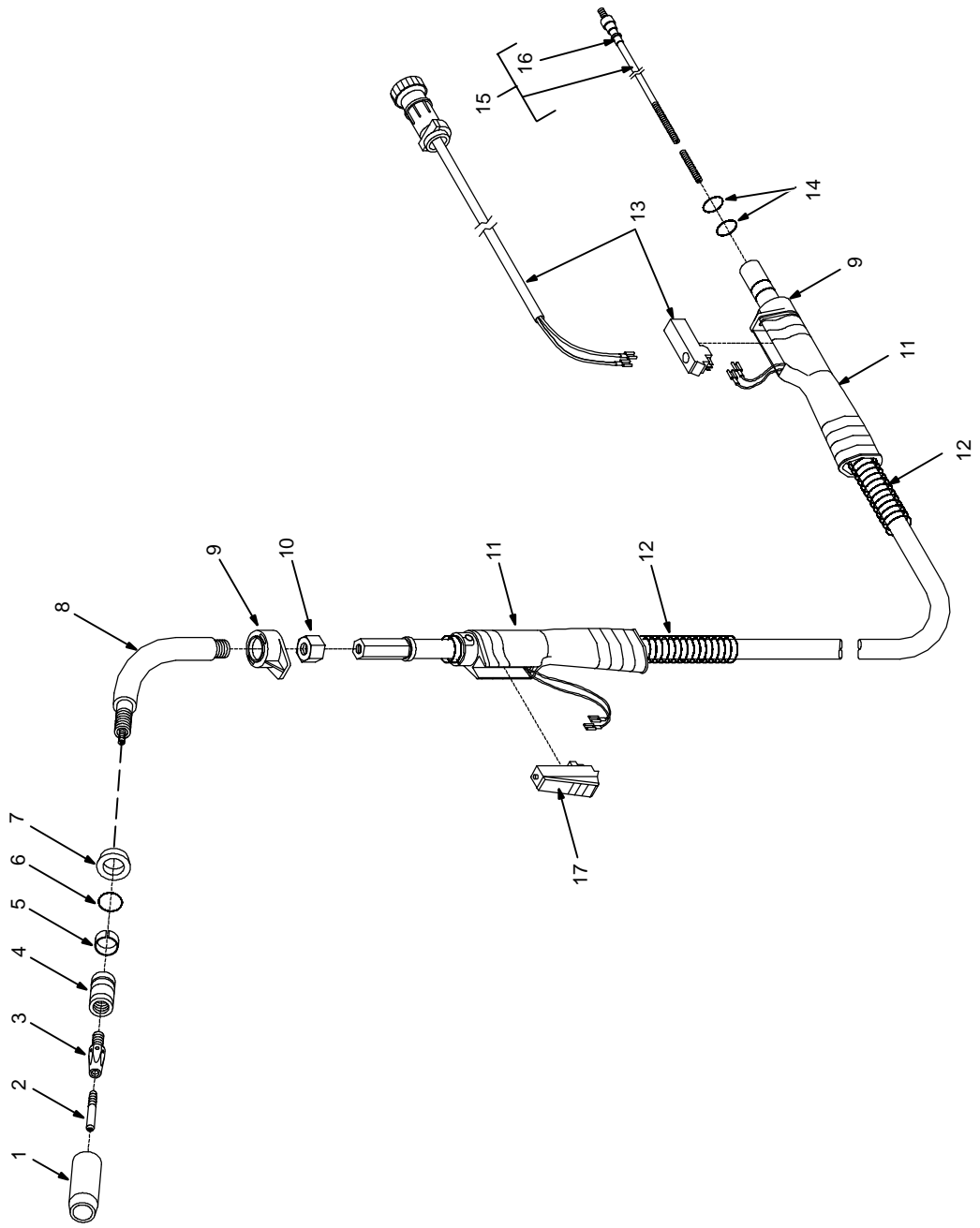

Figure 7-5. M-25 Gun

Ref. 800 792-B

Item No.	Part No.	Description	Quantity
----------	----------	-------------	----------

Figure 7-5. M-25 Gun (Fig 7-1 Item 16)

...	1	200 258	.. NOZZLE, slip type .500 orf flush	1
...	1	◆169 724	.. NOZZLE, slip type .500 orf .125 recess	
...	1	◆169 725	.. NOZZLE, slip type .625 orf .125 recess	
...	1	◆169 726	.. NOZZLE, slip type .625 orf flush	
...	1	◆169 727	.. NOZZLE, slip type .625 orf .125 stickout	
...	2	◆087 299	.. TIP, contact scr .023 wire x 1.125	
...	2	◆000 067	.. TIP, contact scr .030 wire x 1.125	
...	2	◆000 068	.. TIP, contact scr .035 wire x 1.125	
...	2	◆000 069	.. TIP, contact scr .045 wire x 1.125	
...	3	169 728	.. ADAPTER, contact tip	1
...	4	169 729	.. ADAPTER, nozzle	1
...	5	170 467	.. RING, retaining	1
...	6	170 468	.. O-RING	1
...	7	169 730	.. WASHER, shock	1
...	8	169 731	.. TUBE, head	1
...	9	169 738	.. NUT, locking handle	2
...	10	194 523	.. NUT, jam	1
...	11	169 737	.. HANDLE	2
...	12	169 741	.. STRAIN RELIEF, cable	2
...	13	180 433	.. CORD, trigger assembly	1
...	14	079 974	.. O-RING, .500 ID x .103CS rbr	2
...	15	◆194 010	.. LINER, monocoil .023/.025 wire x 15ft (consisting of)	1
...	15	◆194 011	.. LINER, monocoil .030/.035 wire x 15ft (consisting of)	1
...	15	◆194 012	.. LINER, monocoil .035/.045 wire x 15ft (consisting of)	1
...	16	079 975	.. O-RING, .187 ID x .103CS rbr	1
...	17	196 255	.. SWITCH, trigger	1

◆OPTIONAL

To maintain the factory original performance of your equipment, use only Manufacturer's Suggested Replacement Parts. Model and serial number required when ordering parts from your local distributor.

Item No.	Dia. Mkgs.	Part No.	Description	Quantity
204857 Figure 7-6. Wire Drive And Gears (Figure 7-2 Item 24)				
1		602009	SCREW,.250-20 x 1.25 soc hd gr 8	1
2		172075	CARRIER,DRIVE ROLL W/COMPONENTS	1
3		166072	SPACER,GEAR	1
4		010224	PIN,SPRING CS .187 X 1.000	1
5		182788	HOUSING,ADAPTER GUN/FEEDER	1
6		085242	FASTENER,PINNED	1
7		085 244	WASHER, cupped stl .328 ID x .812 OD x .125 lip	1
8		196896	CUP,SPRING	1
9		196897	SPRING,CPRSN .695 OD X .095 WIRE	1
10		196895	KNOB,TENSION ADJ	1
11		166071	LEVER,MTG PRESSURE GEAR	1
12		204510	PIN,HINGE	1
13		151828	PIN,COTTER HAIR .054 X .750	1
14		173616	COVER,RIGHT ANGLE MOTOR	1
15		202888	MOTOR,GEAR 24VDC 122RPM 20:1 RATIO (CONSISTING OF)	1
		193633	KEY,WOODRUFF .118 X .380	1
		193634	WASHER,WAVE .405 ID X .740 OD	2
		193635	RING,RTNG EXT .394 SHAFT X	1
16		079633	FITTING,HOSE BRS BARBED M 3/16TBG	1
17		601966	SCREW,.375-16 X 1.25HEXHD	2
18		604538	WASHER,FLAT STL SAE .312	1
19		204585	KNOB	1
20		173619	CARRIER,DRIVE ROLL W/COMPONENTS	1
21		174609	SCREW,M 4-.7 x 12	1
22		174610	SCREW,M 6-1.0 X 20 SOC HD	3
23		192029	WASHER,FLAT .250 ID X .437 OD	3
24		173620	BUSHING,MOTOR MTG	3
25		602243	WASHER,FLAT .438 ID X 1.00 OD	1
26		602213	WASHER,LOCK .380 ID X .683 OD	1
		203526	ROLL,DRIVE V GROOVE .030/.035 COMB WIRE	2
		056192	GUIDE,WIRE INLET	1
		*045127	GUIDE,WIRE INLET ANTI-WEAR	1

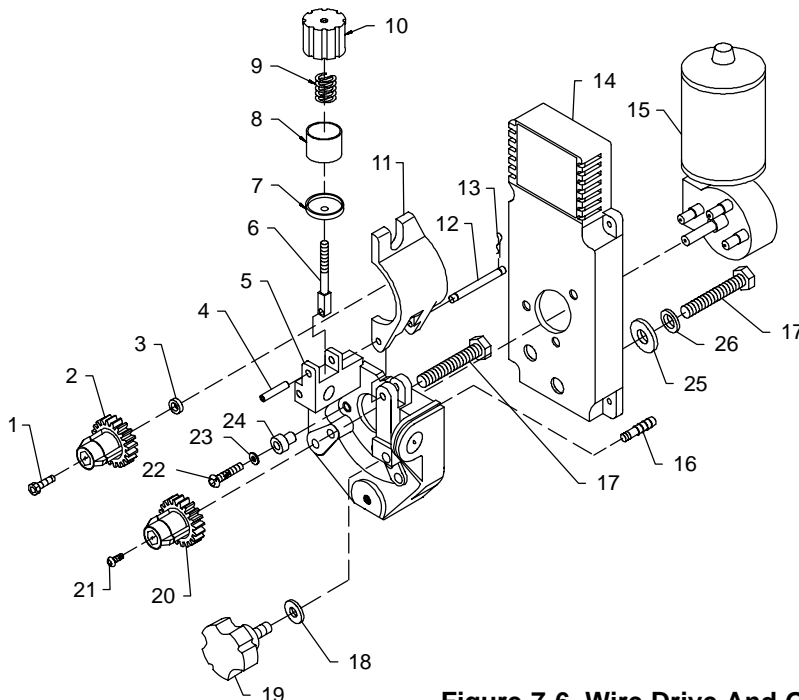

**See Table 7-1
Drive Roll & Wire Guide Kits.**

 Hardware is common and not available unless listed.

Figure 7-6. Wire Drive And Gears

802 986-A

*Recommended Spare Parts.

To maintain the factory original performance of your equipment, use only Manufacturer's Suggested Replacement Parts. Model and serial number required when ordering parts from your local distributor.

Table 7-1. Drive Roll And Wire Guide Kits

Note 

Base selection of drive rolls upon the following recommended usages:

- 1 V-Grooved rolls for hard wire.
- 2 U-Grooved rolls for soft and soft shelled cored wires.
- 3 U-Cogged rolls for extremely soft shelled wires (usually hard surfacing types).
- 4 V-Knurled rolls for hard shelled cored wires.
- 5 Drive roll types may be mixed to suit particular requirements (example: V-Knurled roll in combination with U-Grooved).

Wire Diameter			Kit No.	Drive Roll		Inlet Wire Guide
Fraction	Decimal	Metric		Part No.	Type	
.023/.025 in.	.023/.025 in	0.6 mm	087 131	087 130	V-Grooved	056 192
.030/.035 in.	.030/.035 in.	0.8/0.9 mm	204 579	203 526	V-Grooved	056 192
.030 in.	.030 in.	0.8 mm	079 594	053 695	V-Grooved	056 192
.035 in.	.035 in.	0.9 mm	079 595	053 700	V-Grooved	056 192
.045 in.	.045 in.	1.2 mm	079 596	053 697	V-Grooved	056 193

Ref. S-0026-B/7-91

TRUE BLUE[®]

WARRANTY

Effective January 1, 2000

(Equipment with a serial number preface of "LA" or newer)

This limited warranty supersedes all previous Miller warranties and is exclusive with no other guarantees or warranties expressed or implied.

Warranty Questions?

Call
1-800-4-A-MILLER
for your local
Miller distributor.

Your distributor also gives
you ...

Service

You always get the fast,
reliable response you
need. Most replacement
parts can be in your
hands in 24 hours.

Support

Need fast answers to the
tough welding questions?
Contact your distributor.
The expertise of the
distributor and Miller is
there to help you, every
step of the way.

LIMITED WARRANTY – Subject to the terms and conditions below, Miller Electric Mfg. Co., Appleton, Wisconsin, warrants to its original retail purchaser that new Miller equipment sold after the effective date of this limited warranty is free of defects in material and workmanship at the time it is shipped by Miller. THIS WARRANTY IS EXPRESSLY IN LIEU OF ALL OTHER WARRANTIES, EXPRESS OR IMPLIED, INCLUDING THE WARRANTIES OF MERCHANTABILITY AND FITNESS.

Within the warranty periods listed below, Miller will repair or replace any warranted parts or components that fail due to such defects in material or workmanship. Miller must be notified in writing within thirty (30) days of such defect or failure, at which time Miller will provide instructions on the warranty claim procedures to be followed.

Miller shall honor warranty claims on warranted equipment listed below in the event of such a failure within the warranty time periods. All warranty time periods start on the date that the equipment was delivered to the original retail purchaser, or one year after the equipment is sent to a North American distributor or eighteen months after the equipment is sent to an International distributor.

1. 5 Years Parts – 3 Years Labor
 - * Original main power rectifiers
 - * Inverters (input and output rectifiers only)
2. 3 Years — Parts and Labor
 - * Transformer/Rectifier Power Sources
 - * Plasma Arc Cutting Power Sources
 - * Semi-Automatic and Automatic Wire Feeders
 - * Inverter Power Supplies
 - * Intelligig
 - * Engine Driven Welding Generators
(NOTE: Engines are warranted separately by the engine manufacturer.)
3. 1 Year — Parts and Labor
 - * DS-2 Wire Feeder
 - * Motor Driven Guns (w/exception of Spoolmate 185 & Spoolmate 250)
 - * Process Controllers
 - * Positioners and Controllers
 - * Automatic Motion Devices
 - * RFCS Foot Controls
 - * Induction Heating Power Sources
 - * Water Coolant Systems
 - * HF Units
 - * Grids
 - * Maxstar 140
 - * Spot Welders
 - * Load Banks
 - * Miller Cyclomatic Equipment
 - * Running Gear/Trailers
 - * Plasma Cutting Torches (except APT & SAF Models)
 - * Field Options
(NOTE: Field options are covered under True Blue[®] for the remaining warranty period of the product they are installed in, or for a minimum of one year — whichever is greater.)
4. 6 Months — Batteries
5. 90 Days — Parts
 - * MIG Guns/TIG Torches
 - * Induction Heating Coils and Blankets

- * APT, ZIPCUT & PLAZCUT Model Plasma Cutting Torches
- * Remote Controls
- * Accessory Kits
- * Replacement Parts (No labor)
- * Spoolmate 185 & Spoolmate 250
- * Canvas Covers

Miller's True Blue[®] Limited Warranty shall not apply to:

1. **Consumable components; such as contact tips, cutting nozzles, contactors, brushes, slip rings, relays or parts that fail due to normal wear.**
2. Items furnished by Miller, but manufactured by others, such as engines or trade accessories. These items are covered by the manufacturer's warranty, if any.
3. Equipment that has been modified by any party other than Miller, or equipment that has been improperly installed, improperly operated or misused based upon industry standards, or equipment which has not had reasonable and necessary maintenance, or equipment which has been used for operation outside of the specifications for the equipment.

MILLER PRODUCTS ARE INTENDED FOR PURCHASE AND USE BY COMMERCIAL/INDUSTRIAL USERS AND PERSONS TRAINED AND EXPERIENCED IN THE USE AND MAINTENANCE OF WELDING EQUIPMENT.

In the event of a warranty claim covered by this warranty, the exclusive remedies shall be, at Miller's option: (1) repair; or (2) replacement; or, where authorized in writing by Miller in appropriate cases, (3) the reasonable cost of repair or replacement at an authorized Miller service station; or (4) payment of or credit for the purchase price (less reasonable depreciation based upon actual use) upon return of the goods at customer's risk and expense. Miller's option of repair or replacement will be F.O.B., Factory at Appleton, Wisconsin, or F.O.B. at a Miller authorized service facility as determined by Miller. Therefore no compensation or reimbursement for transportation costs of any kind will be allowed.

TO THE EXTENT PERMITTED BY LAW, THE REMEDIES PROVIDED HEREIN ARE THE SOLE AND EXCLUSIVE REMEDIES. IN NO EVENT SHALL MILLER BE LIABLE FOR DIRECT, INDIRECT, SPECIAL, INCIDENTAL OR CONSEQUENTIAL DAMAGES (INCLUDING LOSS OF PROFIT), WHETHER BASED ON CONTRACT, TORT OR ANY OTHER LEGAL THEORY.

ANY EXPRESS WARRANTY NOT PROVIDED HEREIN AND ANY IMPLIED WARRANTY, GUARANTY OR REPRESENTATION AS TO PERFORMANCE, AND ANY REMEDY FOR BREACH OF CONTRACT TORT OR ANY OTHER LEGAL THEORY WHICH, BUT FOR THIS PROVISION, MIGHT ARISE BY IMPLICATION, OPERATION OF LAW, CUSTOM OF TRADE OR COURSE OF DEALING, INCLUDING ANY IMPLIED WARRANTY OF MERCHANTABILITY OR FITNESS FOR PARTICULAR PURPOSE, WITH RESPECT TO ANY AND ALL EQUIPMENT FURNISHED BY MILLER IS EXCLUDED AND DISCLAIMED BY MILLER.

Some states in the U.S.A. do not allow limitations of how long an implied warranty lasts, or the exclusion of incidental, indirect, special or consequential damages, so the above limitation or exclusion may not apply to you. This warranty provides specific legal rights, and other rights may be available, but may vary from state to state.

In Canada, legislation in some provinces provides for certain additional warranties or remedies other than as stated herein, and to the extent that they may not be waived, the limitations and exclusions set out above may not apply. This Limited Warranty provides specific legal rights, and other rights may be available, but may vary from province to province.





Owner's Record

Please complete and retain with your personal records.

Model Name	Serial/Style Number
Purchase Date	(Date which equipment was delivered to original customer.)
Distributor	
Address	
City	
State	Zip



For Service

Call 1-800-4-A-Miller or see our website at www.MillerWelds.com to locate a DISTRIBUTOR or SERVICE AGENCY near you.

Always provide Model Name and Serial/Style Number.

Contact your Distributor for:

- Welding Supplies and Consumables
- Options and Accessories
- Personal Safety Equipment
- Service and Repair
- Replacement Parts
- Training (Schools, Videos, Books)
- Technical Manuals (Servicing Information and Parts)
- Circuit Diagrams
- Welding Process Handbooks

Contact the Delivering Carrier for:

File a claim for loss or damage during shipment.

For assistance in filing or settling claims, contact your distributor and/or equipment manufacturer's Transportation Department.

Miller Electric Mfg. Co.

An Illinois Tool Works Company
1635 West Spencer Street
Appleton, WI 54914 USA

International Headquarters—USA

USA Phone: 920-735-4505 Auto-Attended
USA & Canada FAX: 920-735-4134
International FAX: 920-735-4125

European Headquarters – United Kingdom

Phone: 44 (0) 1204-593493
FAX: 44 (0) 1204-598066

www.MillerWelds.com

