



OM-1316

186 229F

March 2000

Processes



MIG (GMAW)

Flux Cored (FCAW)

Description



Wire Feeder

Millermatic® 130XP And M-10 Gun

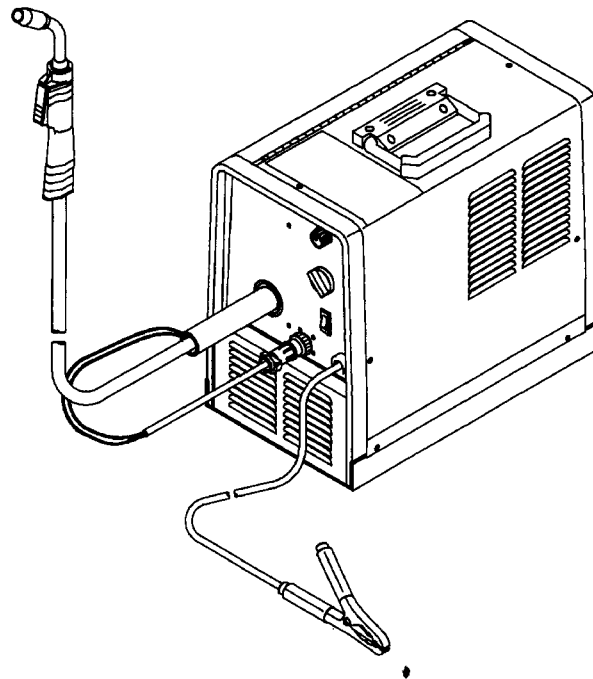

OWNER'S MANUAL



Visit our website at
www.MillerWelds.com

From Miller to You

Thank you and congratulations on choosing Miller. Now you can get the job done and get it done right. We know you don't have time to do it any other way.

That's why when Niels Miller first started building arc welders in 1929, he made sure his products offered long-lasting value and superior quality. Like you, his customers couldn't afford anything less. Miller products had to be more than the best they could be. They had to be the best you could buy.

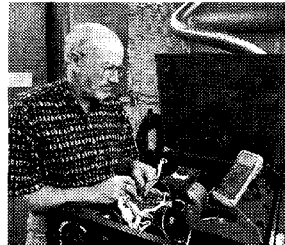

Today, the people that build and sell Miller products continue the tradition. They're just as committed to providing equipment and service that meets the high standards of quality and value established in 1929.

This Owner's Manual is designed to help you get the most out of your Miller products. Please take time to read the Safety precautions. They will help you protect yourself against potential hazards on the worksite. We've

made installation and operation quick and easy. With Miller you can count on years of reliable service with proper maintenance. And if for some reason the unit needs repair, there's a Troubleshooting section that will help you figure out what the problem is. The parts list will then help you to decide which exact part you may need to fix the problem. Warranty and service information for your particular model are also provided.



Miller is the first welding equipment manufacturer in the U.S.A. to be registered to the ISO 9001 Quality System Standard.

Miller Electric manufactures a full line of welders and welding related equipment. For information on other quality Miller products, contact your local Miller distributor to receive the latest full line catalog or individual catalog sheets. To locate your nearest distributor call 1-800-4-A-Miller, or visit us at www.MillerWelds.com on the web.

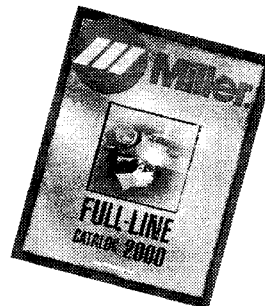

Working as hard as you do - every power source from Miller is backed by the most hassle-free warranty in the business.

Miller offers a Technical Manual which provides more detailed service and parts information for your unit. To obtain a Technical Manual, contact your local distributor. Your distributor can also supply you with Welding Process Manuals such as SMAW, GTAW, GMAW, and GMAW-P.



TABLE OF CONTENTS

WARNING

This product, when used for welding or cutting, produces fumes or gases which contain chemicals known to the State of California to cause birth defects and, in some cases, cancer. (California Health & Safety Code Section 25249.5 et seq.)

The following terms are used interchangeably throughout this manual:
MIG = GMAW

SECTION 1 - SAFETY PRECAUTIONS - READ BEFORE USING	1
1-1. Symbol Usage	1
1-2. Arc Welding Hazards	1
1-3. Additional Symbols For Installation, Operation, And Maintenance	3
1-4. Principal Safety Standards	3
1-5. EMF Information	4
SECTION 1 - CONSIGNES DE SECURITE - LIRE AVANT UTILISATION	5
1-1. Signification des symboles	5
1-2. Dangers relatifs au soudage à l'arc	5
1-3. Dangers supplémentaires en relation avec l'installation, le fonctionnement et la maintenance	7
1-4. Principales normes de sécurité	8
1-5. Information sur les champs électromagnétiques	8
SECTION 2 - SPECIFICATIONS	9
2-1. Specifications	9
2-2. Welding Power Source Duty Cycle And Overheating	9
2-3. Welding Gun Duty Cycle And Overheating	10
2-4. Volt-Ampere Curves	10
SECTION 3 - INSTALLATION	11
3-1. Selecting A Location	11
3-2. Installing Work Clamp	11
3-3. Installing Welding Gun And Changing Polarity	12
3-4. Installing Gas Supply	13
3-5. Installing Wire Spool And Adjusting Hub Tension	14
3-6. Installing Drive Roll, Wire Guide And Threading Welding Wire	15
3-7. Weld Parameter	16
SECTION 4 - OPERATION	17
4-1. Controls	17
SECTION 5 - MAINTENANCE & TROUBLESHOOTING	18
5-1. Routine Maintenance	18
5-2. Drive Motor Fuse F1	18
5-3. Short Circuit Shutdown	18
5-4. Cleaning Or Repairing Drive Assembly	19
5-5. Replacing Gun Contact Tip	20
5-6. Cleaning Or Replacing Gun Liner	21
5-7. Replacing Switch And/Or Head Tube	22
5-8. Troubleshooting Table	23
SECTION 6 - ELECTRICAL DIAGRAM	24
SECTION 7 - MIG WELDING (GMAW) GUIDELINES	25
7-1. Typical MIG Process Connections	25
7-2. Typical MIG Process Control Settings	26
7-3. Holding And Positioning Welding Gun	27
7-4. Conditions That Affect Weld Bead Shape	28
7-5. Gun Movement During Welding	29
7-6. Poor Weld Bead Characteristics	29
7-7. Good Weld Bead Characteristics	29
7-8. Troubleshooting - Excessive Spatter	30
7-9. Troubleshooting - Porosity	30
7-10. Troubleshooting - Excessive Penetration	31
7-11. Troubleshooting - Lack Of Penetration	31
7-12. Troubleshooting - Incomplete Fusion	31
7-13. Troubleshooting - Burn-Through	32
7-14. Troubleshooting - Waviness Of Bead	32
7-15. Troubleshooting - Distortion	32
7-16. Common MIG Shielding Gases	33
SECTION 8 - PARTS LIST	34
OPTIONS AND ACCESSORIES	
WARRANTY	

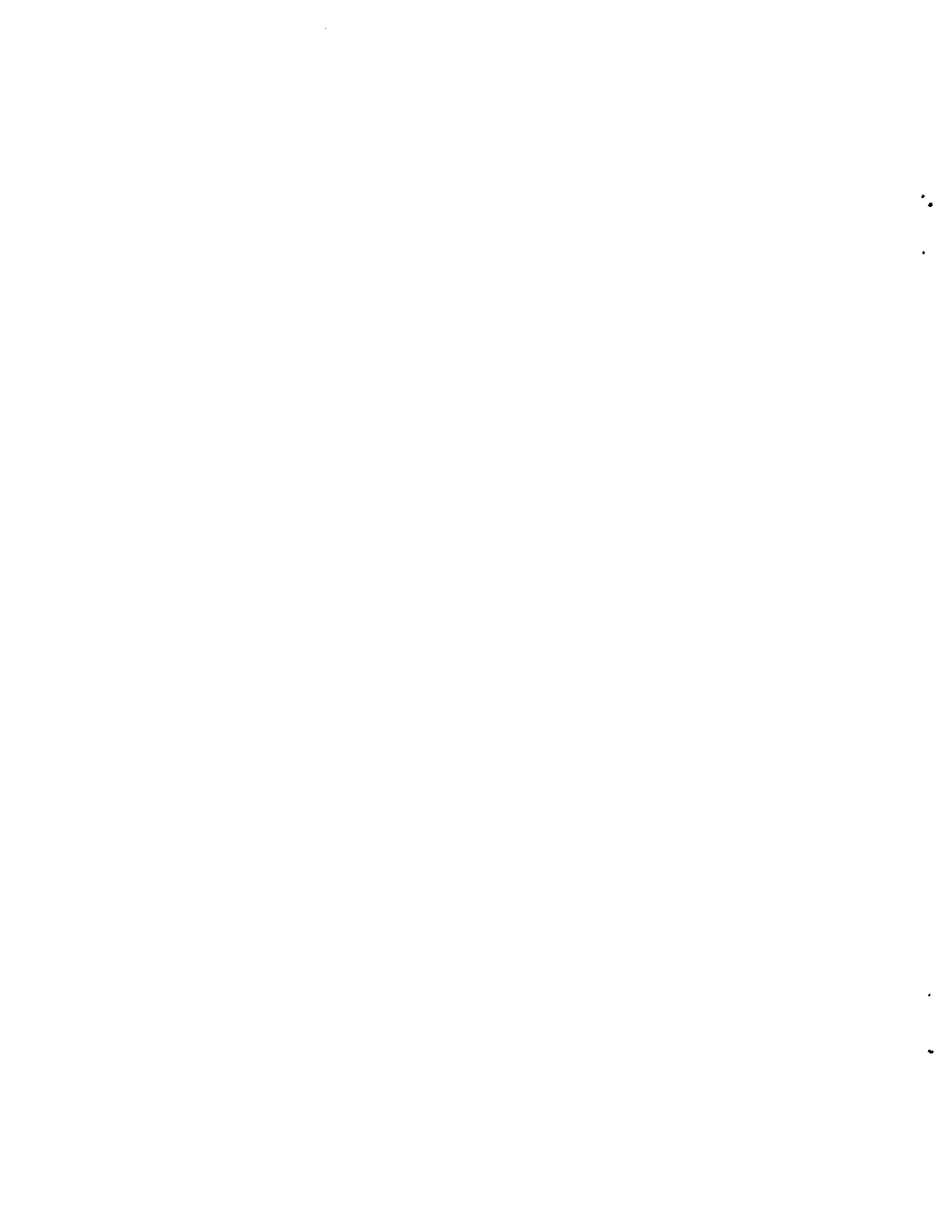

SECTION 1 - SAFETY PRECAUTIONS - READ BEFORE USING

som_nd_4/98

1-1. Symbol Usage



Means Warning! Watch Out! There are possible hazards with this procedure! The possible hazards are shown in the adjoining symbols.

▲ Marks a special safety message.

☞ Means "Note"; not safety related.



This group of symbols means Warning! Watch Out! possible ELECTRIC SHOCK, MOVING PARTS, and HOT PARTS hazards. Consult symbols and related instructions below for necessary actions to avoid the hazards.

1-2. Arc Welding Hazards

▲ The symbols shown below are used throughout this manual to call attention to and identify possible hazards. When you see the symbol, watch out, and follow the related instructions to avoid the hazard. The safety information given below is only a summary of the more complete safety information found in the Safety Standards listed in Section 1-4. Read and follow all Safety Standards.

▲ Only qualified persons should install, operate, maintain, and repair this unit.

▲ During operation, keep everybody, especially children, away.



ELECTRIC SHOCK can kill.

Touching live electrical parts can cause fatal shocks or severe burns. The electrode and work circuit is electrically live whenever the output is on. The input power circuit and machine internal circuits are also live when power is on. In semiautomatic or automatic wire welding, the wire, wire reel, drive roll housing, and all metal parts touching the welding wire are electrically live. Incorrectly installed or improperly grounded equipment is a hazard.

- Do not touch live electrical parts.
- Wear dry, hole-free insulating gloves and body protection.
- Insulate yourself from work and ground using dry insulating mats or covers big enough to prevent any physical contact with the work or ground.
- Do not use AC output in damp areas, if movement is confined, or if there is a danger of falling.
- Use AC output ONLY if required for the welding process.
- If AC output is required, use remote output control if present on unit.
- Disconnect input power or stop engine before installing or servicing this equipment. Lockout/tagout input power according to OSHA 29 CFR 1910.147 (see Safety Standards).
- Properly install and ground this equipment according to its Owner's Manual and national, state, and local codes.
- Always verify the supply ground - check and be sure that input power cord ground wire is properly connected to ground terminal in disconnect box or that cord plug is connected to a properly grounded receptacle outlet.
- When making input connections, attach proper grounding conductor first - double-check connections.
- Frequently inspect input power cord for damage or bare wiring - replace cord immediately if damaged - bare wiring can kill.
- Turn off all equipment when not in use.
- Do not use worn, damaged, undersized, or poorly spliced cables.
- Do not drape cables over your body.

- If earth grounding of the workpiece is required, ground it directly with a separate cable.
- Do not touch electrode if you are in contact with the work, ground, or another electrode from a different machine.
- Use only well-maintained equipment. Repair or replace damaged parts at once. Maintain unit according to manual.
- Wear a safety harness if working above floor level.
- Keep all panels and covers securely in place.
- Clamp work cable with good metal-to-metal contact to workpiece or worktable as near the weld as practical.
- Insulate work clamp when not connected to workpiece to prevent contact with any metal object.
- Do not connect more than one electrode or work cable to any single weld output terminal.

SIGNIFICANT DC VOLTAGE exists after removal of input power on inverters.

- Turn Off inverter, disconnect input power, and discharge input capacitors according to instructions in Maintenance Section before touching any parts.



FUMES AND GASES can be hazardous.

Welding produces fumes and gases. Breathing these fumes and gases can be hazardous to your health.

- Keep your head out of the fumes. Do not breathe the fumes.
- If inside, ventilate the area and/or use exhaust at the arc to remove welding fumes and gases.
- If ventilation is poor, use an approved air-supplied respirator.
- Read the Material Safety Data Sheets (MSDSs) and the manufacturer's instructions for metals, consumables, coatings, cleaners, and degreasers.
- Work in a confined space only if it is well ventilated, or while wearing an air-supplied respirator. Always have a trained watch-person nearby. Welding fumes and gases can displace air and lower the oxygen level causing injury or death. Be sure the breathing air is safe. ♣
- Do not weld in locations near degreasing, cleaning, or spraying operations. The heat and rays of the arc can react with vapors to form highly toxic and irritating gases.
- Do not weld on coated metals, such as galvanized, lead, or cadmium plated steel, unless the coating is removed from the weld area, the area is well ventilated, and if necessary, while wearing an air-supplied respirator. The coatings and any metals containing these elements can give off toxic fumes if welded.



ARC RAYS can burn eyes and skin.

Arc rays from the welding process produce intense visible and invisible (ultraviolet and infrared) rays that can burn eyes and skin. Sparks fly off from the weld.

- Wear a welding helmet fitted with a proper shade of filter to protect your face and eyes when welding or watching (see ANSI Z49.1 and Z87.1 listed in Safety Standards).
- Wear approved safety glasses with side shields under your helmet.
- Use protective screens or barriers to protect others from flash and glare; warn others not to watch the arc.
- Wear protective clothing made from durable, flame-resistant material (leather and wool) and foot protection.



WELDING can cause fire or explosion.

Welding on closed containers, such as tanks, drums, or pipes, can cause them to blow up. Sparks can fly off from the welding arc. The flying sparks, hot workpiece, and hot equipment can cause fires and burns. Accidental contact of electrode to metal objects can cause sparks, explosion, overheating, or fire. Check and be sure the area is safe before doing any welding.

- Protect yourself and others from flying sparks and hot metal.
- Do not weld where flying sparks can strike flammable material.
- Remove all flammables within 35 ft (10.7 m) of the welding arc. If this is not possible, tightly cover them with approved covers.
- Be alert that welding sparks and hot materials from welding can easily go through small cracks and openings to adjacent areas.
- Watch for fire, and keep a fire extinguisher nearby.
- Be aware that welding on a ceiling, floor, bulkhead, or partition can cause fire on the hidden side.
- Do not weld on closed containers such as tanks, drums, or pipes, unless they are properly prepared according to AWS F4.1 (see Safety Standards).
- Connect work cable to the work as close to the welding area as practical to prevent welding current from traveling long, possibly unknown paths and causing electric shock and fire hazards.
- Do not use welder to thaw frozen pipes.
- Remove stick electrode from holder or cut off welding wire at contact tip when not in use.
- Wear oil-free protective garments such as leather gloves, heavy shirt, cuffless trousers, high shoes, and a cap.
- Remove any combustibles, such as a butane lighter or matches, from your person before doing any welding.

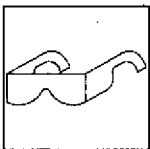

FLYING METAL can injure eyes.

- Welding, chipping, wire brushing, and grinding cause sparks and flying metal. As welds cool, they can throw off slag.
- Wear approved safety glasses with side shields even under your welding helmet.



BUILDUP OF GAS can injure or kill.

- Shut off shielding gas supply when not in use.
- Always ventilate confined spaces or use approved air-supplied respirator.

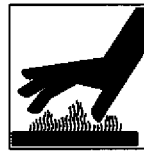

HOT PARTS can cause severe burns.

- Do not touch hot parts bare handed.
- Allow cooling period before working on gun or torch.

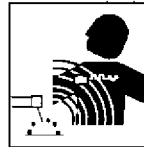

MAGNETIC FIELDS can affect pacemakers.

- Pacemaker wearers keep away.
- Wearers should consult their doctor before going near arc welding, gouging, or spot welding operations.

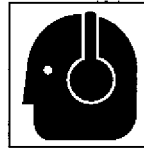

NOISE can damage hearing.

Noise from some processes or equipment can damage hearing.

- Wear approved ear protection if noise level is high.

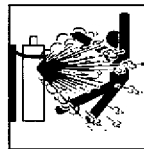

CYLINDERS can explode if damaged.

Shielding gas cylinders contain gas under high pressure. If damaged, a cylinder can explode. Since gas cylinders are normally part of the welding process, be sure to treat them carefully.

- Protect compressed gas cylinders from excessive heat, mechanical shocks, slag, open flames, sparks, and arcs.
- Install cylinders in an upright position by securing to a stationary support or cylinder rack to prevent falling or tipping.
- Keep cylinders away from any welding or other electrical circuits.
- Never drape a welding torch over a gas cylinder.
- Never allow a welding electrode to touch any cylinder.
- Never weld on a pressurized cylinder - explosion will result.
- Use only correct shielding gas cylinders, regulators, hoses, and fittings designed for the specific application; maintain them and associated parts in good condition.
- Turn face away from valve outlet when opening cylinder valve.
- Keep protective cap in place over valve except when cylinder is in use or connected for use.
- Read and follow instructions on compressed gas cylinders, associated equipment, and CGA publication P-1 listed in Safety Standards.

1-3. Additional Symbols For Installation, Operation, And Maintenance



FIRE OR EXPLOSION hazard.

- Do not install or place unit on, over, or near combustible surfaces.
- Do not install unit near flammables.
- Do not overload building wiring - be sure power supply system is properly sized, rated, and protected to handle this unit.



MOVING PARTS can cause injury.

- Keep away from moving parts such as fans.
- Keep all doors, panels, covers, and guards closed and securely in place.



FALLING UNIT can cause injury.

- Use lifting eye to lift unit only, NOT running gear, gas cylinders, or any other accessories.
- Use equipment of adequate capacity to lift and support unit.
- If using lift forks to move unit, be sure forks are long enough to extend beyond opposite side of unit.

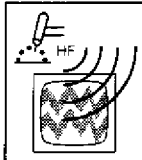

H.F. RADIATION can cause interference.

- High-frequency (H.F.) can interfere with radio navigation, safety services, computers, and communications equipment.
- Have only qualified persons familiar with electronic equipment perform this installation.
- The user is responsible for having a qualified electrician promptly correct any interference problem resulting from the installation.
- If notified by the FCC about interference, stop using the equipment at once.
- Have the installation regularly checked and maintained.
- Keep high-frequency source doors and panels tightly shut, keep spark gaps at correct setting, and use grounding and shielding to minimize the possibility of interference.

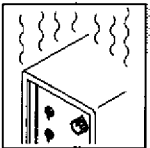

OVERUSE can cause OVERHEATING

- Allow cooling period; follow rated duty cycle.
- Reduce current or reduce duty cycle before starting to weld again.
- Do not block or filter airflow to unit.

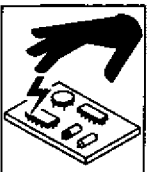

STATIC (ESD) can damage PC boards.

- Put on grounded wrist strap BEFORE handling boards or parts.
- Use proper static-proof bags and boxes to store, move, or ship PC boards.



MOVING PARTS can cause injury.

- Keep away from moving parts.
- Keep away from pinch points such as drive rolls.



WELDING WIRE can cause injury.

- Do not press gun trigger until instructed to do so.
- Do not point gun toward any part of the body, other people, or any metal when threading welding wire.

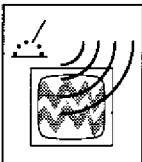

ARC WELDING can cause interference.

- Electromagnetic energy can interfere with sensitive electronic equipment such as computers and computer-driven equipment such as robots.
- Be sure all equipment in the welding area is electromagnetically compatible.
- To reduce possible interference, keep weld cables as short as possible, close together, and down low, such as on the floor.
- Locate welding operation 100 meters from any sensitive electronic equipment.
- Be sure this welding machine is installed and grounded according to this manual.
- If interference still occurs, the user must take extra measures such as moving the welding machine, using shielded cables, using line filters, or shielding the work area.

1-4. Principal Safety Standards

Safety in Welding and Cutting, ANSI Standard Z49.1, from American Welding Society, 550 N.W. LeJeune Rd, Miami FL 33126

Safety and Health Standards, OSHA 29 CFR 1910, from Superintendent of Documents, U.S. Government Printing Office, Washington, D.C. 20402.

Recommended Safe Practices for the Preparation for Welding and Cutting of Containers That Have Held Hazardous Substances, American Welding Society Standard AWS F4.1, from American Welding Society, 550 N.W. LeJeune Rd, Miami, FL 33126

National Electrical Code, NFPA Standard 70, from National Fire Protection Association, Batterymarch Park, Quincy, MA 02269.

Safe Handling of Compressed Gases in Cylinders, CGA Pamphlet P-1, from Compressed Gas Association, 1235 Jefferson Davis Highway, Suite 501, Arlington, VA 22202.

Code for Safety in Welding and Cutting, CSA Standard W117.2, from Canadian Standards Association, Standards Sales, 178 Rexdale Boulevard, Rexdale, Ontario, Canada M9W 1R3.

Safe Practices For Occupation And Educational Eye And Face Protection, ANSI Standard Z87.1, from American National Standards Institute, 1430 Broadway, New York, NY 10018.

Cutting And Welding Processes, NFPA Standard 51B, from National Fire Protection Association, Batterymarch Park, Quincy, MA 02269.

1-5. EMF Information

Considerations About Welding And The Effects Of Low Frequency Electric And Magnetic Fields

Welding current, as it flows through welding cables, will cause electromagnetic fields. There has been and still is some concern about such fields. However, after examining more than 500 studies spanning 17 years of research, a special blue ribbon committee of the National Research Council concluded that: "The body of evidence, in the committee's judgment, has not demonstrated that exposure to power-frequency electric and magnetic fields is a human-health hazard." However, studies are still going forth and evidence continues to be examined. Until the final conclusions of the research are reached, you may wish to minimize your exposure to electromagnetic fields when welding or cutting.

To reduce magnetic fields in the workplace, use the following procedures:

1. Keep cables close together by twisting or taping them.
2. Arrange cables to one side and away from the operator.
3. Do not coil or drape cables around your body.
4. Keep welding power source and cables as far away from operator as practical.
5. Connect work clamp to workpiece as close to the weld as possible.

About Pacemakers:

Pacemaker wearers consult your doctor first. If cleared by your doctor, then following the above procedures is recommended.

SECTION 1 - CONSIGNES DE SECURITE - LIRE AVANT UTILISATION

som_hd_fre 4/98

1-1. Signification des symboles



Signifie Mise en garde ! Soyez vigilant ! Cette procédure présente des risques de danger ! Ceux-ci sont identifiés par des symboles adjacents aux directives.

- ▲ Identifie un message de sécurité particulier.

☞ Signifie **NOTA** ; n'est pas relatif à la sécurité.

1-2. Dangers relatifs au soudage à l'arc

- ▲ Les symboles présentés ci-après sont utilisés tout au long du présent manuel pour attirer votre attention et identifier les risques de danger. Lorsque vous voyez un symbole, soyez vigilant et suivez les directives mentionnées afin d'éviter tout danger. Les consignes de sécurité présentées ci-après ne font que résumer l'information contenue dans les normes de sécurité énumérées à la section 1-4. Veuillez lire et respecter toutes ces normes de sécurité.
- ▲ L'installation, l'utilisation, l'entretien et les réparations ne doivent être confiés qu'à des personnes qualifiées.
- ▲ Au cours de l'utilisation, tenir toute personne à l'écart et plus particulièrement les enfants.



UN CHOC ÉLECTRIQUE peut tuer.

Un simple contact avec des pièces électriques peut provoquer une électrocution ou des blessures graves. L'électrode et le circuit de soudage sont sous tension dès que l'appareil est sur ON. Le circuit d'entrée et les circuits internes de l'appareil sont également sous tension à ce moment-là. En soudage semi-automatique ou automatique, le fil, le dévidoir, le logement des galets d'entraînement et les pièces métalliques en contact avec le fil de soudage sont sous tension. Des matériels mal installés ou mal mis à la terre présentent un danger.

- Ne jamais toucher les pièces électriques sous tension.
- Porter des gants et des vêtements de protection secs ne comportant pas de trous.
- S'isoler de la pièce et de la terre au moyen de tapis ou d'autres moyens isolants suffisamment grands pour empêcher le contact physique éventuel avec la pièce ou la terre.
- Ne pas se servir de source électrique à courant électrique dans les zones humides, dans les endroits confinés ou là où on risque de tomber.
- Se servir d'une source électrique à courant électrique UNIQUEMENT si le procédé de soudage le demande.
- Si l'utilisation d'une source électrique à courant électrique s'avère nécessaire, se servir de la fonction de télécommande si l'appareil en est équipé.
- Couper l'alimentation ou arrêter le moteur avant de procéder à l'installation, à la réparation ou à l'entretien de l'appareil. Déverrouiller l'alimentation selon la norme OSHA 29 CFR 1910.147 (voir normes de sécurité).
- Installer et mettre à la terre correctement cet appareil conformément à son manuel d'utilisation et aux codes nationaux, provinciaux et municipaux.
- Toujours vérifier la terre du cordon d'alimentation - Vérifier et s'assurer que le fil de terre du cordon d'alimentation est bien raccordé à la borne de terre du sectionneur ou que la fiche du cordon est raccordée à une prise correctement mise à la terre.
- En effectuant les raccordements d'entrée fixer d'abord le conducteur de mise à la terre approprié et contre-vérifier les connexions.
- Vérifier fréquemment le cordon d'alimentation pour voir s'il n'est pas endommagé ou dénudé - remplacer le cordon immédiatement s'il est endommagé - un câble dénudé peut provoquer une électrocution.
- Mettre l'appareil hors tension quand on ne l'utilise pas.
- Ne pas utiliser des câbles usés, endommagés, de grosseur insuffisante ou mal épluchés.
- Ne pas enrouler les câbles autour du corps.
- Si la pièce soudée doit être mise à la terre, le faire directement avec un câble distinct.
- Ne pas toucher l'électrode quand on est en contact avec la pièce, la terre ou une électrode provenant d'une autre machine.



Ce groupe de symboles signifie Mise en garde ! Soyez vigilant ! Il y a des risques de danger reliés aux CHOC ÉLECTRIQUES, aux PIÈCES EN MOUVEMENT et aux PIÈCES CHAUDES. Reportez-vous aux symboles et aux directives ci-dessous afin de connaître les mesures à prendre pour éviter tout danger.

- N'utiliser qu'un matériel en bon état. Réparer ou remplacer sur-le-champ les pièces endommagées. Entretien l'appareil conformément à ce manuel.
- Porter un harnais de sécurité quand on travaille en hauteur.
- Maintenir solidement en place tous les panneaux et capots.
- Fixer le câble de retour de façon à obtenir un bon contact métal-métal avec la pièce à souder ou la table de travail, le plus près possible de la soudure.
- Isoler la pince de masse quand pas mis à la pièce pour éviter le contact avec tout objet métallique.

Il y a DU COURANT CONTINU IMPORTANT dans les convertisseurs après la suppression de l'alimentation électrique.

- Arrêter les convertisseurs, débrancher le courant électrique, et décharger les condensateurs d'alimentation selon les instructions indiquées dans la partie entretien avant de toucher les pièces.



LES FUMÉES ET LES GAZ peuvent être dangereux.

Le soudage génère des fumées et des gaz. Leur inhalation peut être dangereux pour votre santé.

- Eloigner votre tête des fumées. Ne pas respirer les fumées.
- A l'intérieur, ventiler la zone et/ou utiliser un échappement au niveau de l'arc pour l'évacuation des fumées et des gaz de soudage.
- Si la ventilation est insuffisante, utiliser un respirateur à alimentation d'air homologué.
- Lire les spécifications de sécurité des matériaux (MSDSs) et les instructions du fabricant concernant les métaux, les consommables, les revêtements, les nettoyants et les dégraissants.
- Travailler dans un espace fermé seulement s'il est bien ventilé ou en portant un respirateur à alimentation d'air. Demander toujours à un surveillant dûment formé de se tenir à proximité. Des fumées et des gaz de soudage peuvent déplacer l'air et abaisser le niveau d'oxygène provoquant des blessures ou des accidents mortels. S'assurer que l'air de respiration ne présente aucun danger.
- Ne pas souder dans des endroits situés à proximité d'opérations de dégraissage, de nettoyage ou de pulvérisation. La chaleur et les rayons de l'arc peuvent réagir en présence de vapeurs et former des gaz hautement toxiques et irritants.
- Ne pas souder des métaux munis d'un revêtement, tels que l'acier galvanisé, plaqué en plomb ou au cadmium à moins que le revêtement n'ait été enlevé dans la zone de soudure, que l'endroit soit bien ventilé, et si nécessaire, en portant un respirateur à alimentation d'air. Les revêtements et tous les métaux renfermant ces éléments peuvent dégager des fumées toxiques en cas de soudage.



LES RAYONS DE L'ARC peuvent provoquer des brûlures dans les yeux et sur la peau.

Le rayonnement de l'arc du procédé de soudage génère des rayons visibles et invisibles intenses (ultraviolets et infrarouges) susceptibles de provoquer

des brûlures dans les yeux et sur la peau. Des étincelles sont projetées pendant le soudage.

- Porter un casque de soudage muni d'un écran de filtre approprié pour protéger votre visage et vos yeux pendant le soudage ou pour regarder (voir ANSI Z49.1 et Z87.1 énuméré dans les normes de sécurité).
- Porter des protections approuvés pour les oreilles si le niveau sonore est trop élevé.
- Utiliser des écrans ou des barrières pour protéger des tiers de l'éclair et de l'éblouissement; demander aux autres personnes de ne pas regarder l'arc.
- Porter des vêtements de protection constitué dans une matière durable, résistant au feu (cuir ou laine) et une protection des pieds.



LE SOUDAGE peut provoquer un incendie ou une explosion.

Le soudage effectué sur des conteneurs fermés tels que des réservoirs, tambours ou des conduites peut provoquer leur éclatement. Des étincelles peuvent être projetées de l'arc de soudure. La projection d'étincelles, des pièces chaudes et des équipements chauds peut provoquer des incendies et des brûlures. Le contact accidentel de l'électrode avec des objets métalliques peut provoquer des étincelles, une explosion, un surchauffement ou un incendie. Avant de commencer le soudage, vérifier et s'assurer que l'endroit ne présente pas de danger.

- Se protéger et d'autres personnes de la projection d'étincelles et de métal chaud.
- Ne pas souder dans un endroit là où des étincelles peuvent tomber sur des substances inflammables.
- Déplacer toutes les substances inflammables à une distance de 10,7 m de l'arc de soudage. En cas d'impossibilité les recouvrir soigneusement avec des protections homologués.
- Des étincelles et des matériaux chauds du soudage peuvent facilement passer dans d'autres zones en traversant de petites fissures et des ouvertures.
- Surveiller tout déclenchement d'incendie et tenir un extincteur à proximité.
- Le soudage effectué sur un plafond, plancher, paroi ou séparation peut déclencher un incendie de l'autre côté.
- Ne pas effectuer le soudage sur des conteneurs fermés tels que des réservoirs, tambours, ou conduites, à moins qu'ils n'aient été préparés correctement conformément à AWS F4.1 (voir les normes de sécurité).
- Brancher le câble sur la pièce le plus près possible de la zone de soudage pour éviter le transport du courant sur une longue distance par des chemins inconnus éventuels en provoquant des risques d'électrocution et d'incendie.
- Ne pas utiliser le poste de soudage pour dégeler des conduites gelées.
- En cas de non utilisation, enlever la baguette d'électrode du porte-électrode ou couper le fil à la pointe de contact.
- Porter des vêtements de protection dépourvus d'huile tels que des gants en cuir, une chemise en matériau lourd, des pantalons sans revers, des chaussures hautes et un couvre chef.
- Avant de souder, retirer toute substance combustible de vos poches telles qu'un allumeur au butane ou des allumettes.

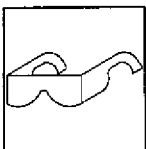

DES PARTICULES VOLANTES peuvent blesser les yeux.

- Le soudage, l'écaillage, le passage de la pièce à la brosse en fil de fer, et le meulage génèrent des étincelles et des particules métalliques volantes. Pendant la période de refroidissement des soudures, elles risquent de projeter du laitier.
- Porter des lunettes de sécurité avec écrans latéraux ou un écran facial.



LES ACCUMULATIONS DE GAZ risquent de provoquer des blessures ou même la mort.

- Fermer l'alimentation du gaz protecteur en cas de non utilisation.
- Veiller toujours à bien aérer les espaces confinés ou se servir d'un respirateur d'adduction d'air homologué.



DES PIÈCES CHAUDES peuvent provoquer des brûlures graves.

- Ne pas toucher des parties chaudes à mains nues
- Prévoir une période de refroidissement avant d'utiliser le pistolet ou la torche.

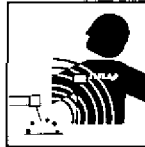

LES CHAMPS MAGNÉTIQUES peuvent affecter les stimulateurs cardiaques.

- Porteurs de stimulateur cardiaque, restez à distance.
- Les porteurs d'un stimulateur cardiaque doivent d'abord consulter leur médecin avant de s'approcher des opérations de soudage à l'arc, de gougeage ou de soudage par points.



LE BRUIT peut affecter l'ouïe.

Le bruit des processus et des équipements peut affecter l'ouïe.

- Porter des protections approuvés pour les oreilles si le niveau sonore est trop élevé.

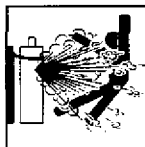

Si des BOUTEILLES sont endommagées, elles pourront exploser.

Des bouteilles de gaz protecteur contiennent du gaz sous haute pression. Si une bouteille est endommagée, elle peut exploser. Du fait que les bouteilles de gaz font normalement partie du procédé de soudage, les

manipuler avec précaution.

- Protéger les bouteilles de gaz comprimé d'une chaleur excessive, des chocs mécaniques, du laitier, des flammes ouvertes, des étincelles et des arcs.
- Placer les bouteilles debout en les fixant dans un support stationnaire ou dans un porte-bouteilles pour les empêcher de tomber ou de se renverser.
- Tenir les bouteilles éloignées des circuits de soudage ou autres circuits électriques.
- Ne jamais placer une torche de soudage sur une bouteille à gaz.
- Une électrode de soudage ne doit jamais entrer en contact avec une bouteille.
- Ne jamais souder une bouteille pressurisée - risque d'explosion.
- Utiliser seulement des bouteilles de gaz protecteur, régulateurs, tuyaux et raccords convenables pour cette application spécifique; les maintenir ainsi que les éléments associés en bon état.
- Ne pas tenir la tête en face de la sortie en ouvrant la soupape de la bouteille.
- Maintenir le chapeau de protection sur la soupape, sauf en cas d'utilisation ou de branchement de la bouteille.
- Lire et suivre les instructions concernant les bouteilles de gaz comprimé, les équipements associés et les publications P-1 CGA énumérées dans les normes de sécurité.

1-3. Dangers supplémentaires en relation avec l'installation, le fonctionnement et la maintenance



Risque D'INCENDIE OU D'EXPLOSION.

- Ne pas placer l'appareil sur, au-dessus ou à proximité de surfaces inflammables.
- Ne pas installer l'appareil à proximité de produits inflammables
- Ne pas surcharger l'installation électrique - s'assurer que l'alimentation est correctement dimensionnée et protégée avant de mettre l'appareil en service.

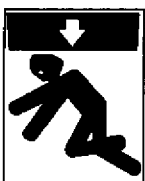

LA CHUTE DE L'APPAREIL peut blesser.

- Utiliser l'anneau de levage uniquement pour soulever l'appareil, NON PAS les chariot, les bouteilles de gaz ou tout autre accessoire.
- Utiliser un engin d'une capacité appropriée pour soulever l'appareil.
- En utilisant des fourches de levage pour déplacer l'unité, s'assurer que les fourches sont suffisamment longues pour dépasser du côté opposé de l'appareil.

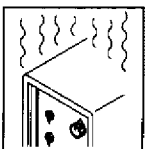

L'EMPLOI EXCESSIF peut SURCHAUFFER L'ÉQUIPEMENT.

- Prévoir une période de refroidissement, respecter le cycle opératoire nominal.
- Réduire le courant ou le cycle opératoire avant de recommencer le soudage.
- Ne pas obstruer les passages d'air du poste.

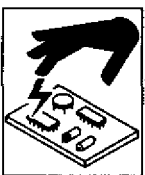

LES CHARGES ÉLECTROSTATIQUES peuvent endommager les circuits imprimés.

- Établir la connexion avec la barrette de terre avant de manipuler des cartes ou des pièces.
- Utiliser des pochettes et des boîtes antistatiques pour stocker, déplacer ou expédier des cartes de circuits imprimés.



DES ORGANES MOBILES peuvent provoquer des blessures.

- Ne pas s'approcher des organes mobiles.
- Ne pas s'approcher des points de coincement tels que des rouleaux de commande.



LES FILS DE SOUDAGE peuvent provoquer des blessures.

- Ne pas appuyer sur la gachette avant d'en avoir reçu l'instruction.
- Ne pas diriger le pistolet vers soi, d'autres personnes ou toute pièce mécanique en engageant le fil de soudage.



DES ORGANES MOBILES peuvent provoquer des blessures.

- Rester à l'écart des organes mobiles comme le ventilateur.
- Maintenir fermés et fixement en place les portes, panneaux, recouvrements et dispositifs de protection.

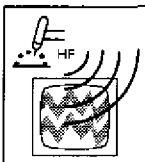

LE RAYONNEMENT HAUTE FRÉQUENCE (H.F.) risque de provoquer des interférences.

- Le rayonnement haute fréquence peut provoquer des interférences avec les équipements de radio-navigation et de communication, les services de sécurité et les ordinateurs.
- Demander seulement à des personnes qualifiées familiarisées avec des équipements électroniques de faire fonctionner l'installation.
- L'utilisateur est tenu de faire corriger rapidement par un électricien qualifié les interférences résultant de l'installation.
- Si le FCC signale des interférences, arrêter immédiatement l'appareil.
- Effectuer régulièrement le contrôle et l'entretien de l'installation.
- Maintenir soigneusement fermés les portes et les panneaux des sources de haute fréquence, maintenir les éclateurs à une distance correcte et utiliser une terre et un blindage pour réduire les interférences éventuelles.



LE SOUDAGE À L'ARC risque de provoquer des interférences.

- L'énergie électromagnétique risque de provoquer des interférences pour l'équipement électronique sensible tel que les ordinateurs et l'équipement commandé par ordinateur tel que les robots.
- Veiller à ce que tout l'équipement de la zone de soudage soit compatible électromagnétiquement.
- Pour réduire la possibilité d'interférence, maintenir les câbles de soudage aussi courts que possible, les grouper, et les poser aussi bas que possible (ex. par terre).
- Veiller à souder à une distance de 100 mètres de tout équipement électronique sensible.
- Veiller à ce que ce poste de soudage soit posé et mis à la terre conformément à ce mode d'emploi.
- En cas d'interférences après avoir pris les mesures précédentes, il incombe à l'utilisateur de prendre des mesures supplémentaires telles que le déplacement du poste, l'utilisation de câbles blindés, l'utilisation de filtres de ligne ou la pose de protecteurs dans la zone de travail.



LES CHAMPS MAGNÉTIQUES peuvent affecter les stimulateurs cardiaques.

- Porteurs de stimulateur cardiaque, restez à distance.
- Les porteurs d'un stimulateur cardiaque doivent d'abord consulter leur médecin avant de s'approcher des opérations de soudage à l'arc, de gougeage ou de soudage par points.

1-4. Principales normes de sécurité

Safety in Welding and Cutting, norme ANSI Z49.1, de l'American Welding Society, 550 N.W. Lejeune Rd, Miami FL 33126

Safety and Health Standards, OSHA 29 CFR 1910, du Superintendent of Documents, U.S. Government Printing Office, Washington, D.C. 20402.

Recommended Safe Practice for the Preparation for Welding and Cutting of Containers That Have Held Hazardous Substances, norme AWS F4.1, de l'American Welding Society, 550 N.W. Lejeune Rd, Miami FL 33126

National Electrical Code, NFPA Standard 70, de la National Fire Protection Association, Batterymarch Park, Quincy, MA 02269.

Safe Handling of Compressed Gases in Cylinders, CGA Pamphlet P-1, de la Compressed Gas Association, 1235 Jefferson Davis Highway, Suite 501, Arlington, VA 22202.

Règles de sécurité en soudage, coupage et procédés connexes, norme CSA W117.2, de l'Association canadienne de normalisation, vente de normes, 178 Rexdale Boulevard, Rexdale (Ontario) Canada M9W 1R3.

Safe Practices For Occupation And Educational Eye And Face Protection, norme ANSI Z87.1, de l'American National Standards Institute, 1430 Broadway, New York, NY 10018.

Cutting and Welding Processes, norme NFPA 51B, de la National Fire Protection Association, Batterymarch Park, Quincy, MA 02269.

1-5. Information sur les champs électromagnétiques

Données sur le soudage électrique et sur les effets, pour l'organisme, des champs magnétiques basse fréquence

Le courant de soudage, pendant son passage dans les câbles de soudage, causera des champs électromagnétiques. Il y a eu et il y a encore un certain souci à propos de tels champs. Cependant, après avoir examiné plus de 500 études qui ont été faites pendant une période de recherche de 17 ans, un comité spécial ruban bleu du National Research Council a conclu: "L'accumulation de preuves, suivant le jugement du comité, n'a pas démontré que l'exposition aux champs magnétiques et champs électriques à haute fréquence représente un risque à la santé humaine". Toutefois, des études sont toujours en cours et les preuves continuent à être examinées. En attendant que les conclusions finales de la recherche soient établies, il vous serait souhaitable de réduire votre exposition aux champs électromagnétiques pendant le soudage ou le coupage.

Afin de réduire les champs électromagnétiques dans l'environnement de travail, respecter les consignes suivantes :

- 1 Garder les câbles ensemble en les torsadant ou en les attachant avec du ruban adhésif.
- 2 Mettre tous les câbles du côté opposé de l'opérateur.
- 3 Ne pas courber pas et ne pas entourer pas les câbles autour de votre corps.
- 4 Garder le poste de soudage et les câbles le plus loin possible de vous.
- 5 Relier la pince de masse le plus près possible de la zone de soudure.

Consignes relatives aux stimulateurs cardiaques :

Les personnes qui portent un stimulateur cardiaque doivent avant tout consulter leur docteur. Si vous êtes déclaré apte par votre docteur, il est alors recommandé de respecter les consignes ci-dessus.



SECTION 2 - SPECIFICATIONS

2-1. Specifications

Rated Welding Output	Amperage Range	Maximum Open-Circuit Voltage DC	Amperes Input at Rated Load Output 115 V, 60 Hz, Single-Phase	KVA	KW	Weight W/ Gun	Overall Dimensions
90 A @ 18 Volts DC, 20% Duty Cycle	30 - 130	28	20 (0.59)*	2.8 0.86*	2.4 0.043*	69 lb (31 kg)	Length: 17 in (432 mm) Width: 10 in (254 mm) Height: 15-1/2 in (394 mm)
Wire Type And Dia	Solid/ Stainless	Flux Cored/ Aluminum	Wire Feed Speed Range At No Load				
	.023 - .030 in (0.6 - 0.8 mm)	.030 - .035 in (0.8 - 0.9 mm)	220 - 700 IPM (5.6 - 18 m/min)				

* While idling

2-2. Welding Power Source Duty Cycle And Overheating

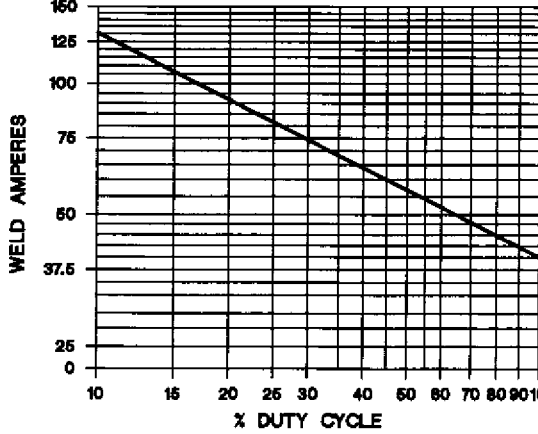

20% Duty Cycle At 90 Amperes

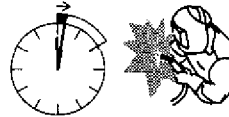
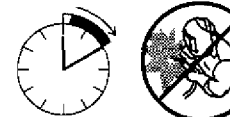

→

Duty Cycle is percentage of 10 minutes that unit can weld at rated load without overheating.

If unit overheats, thermostat(s) opens, output stops, and cooling fan runs. Wait fifteen minutes for unit to cool. Reduce amperage or duty cycle before welding.

▲ Exceeding duty cycle can damage unit or gun and void warranty.

Overheating



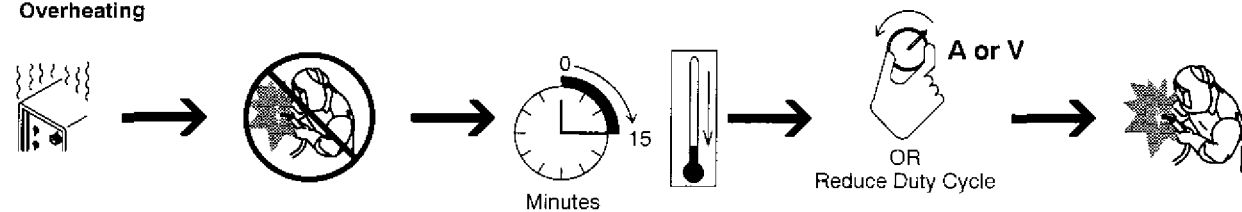

Minutes OR Reduce Duty Cycle

duty1 4/95 - SB-124 655-B



2-3. Welding Gun Duty Cycle And Overheating

CAUTION

WELDING LONGER THAN RATED DUTY CYCLE can damage gun and void warranty.

- Do not weld at rated load longer than shown below.
- Using gasless flux cored wire reduces gun duty cycle.

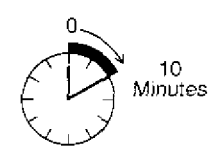
warn7.1 8/93

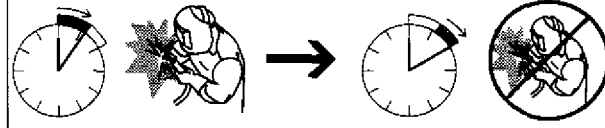
<p>Definition</p>  <p>Duty Cycle is percentage of 10 minutes that gun can weld at rated load without overheating.</p>	<p>.023 To .045 in (0.6 To 1.1 mm) Hard Or Flux Cored Wires 100% Duty Cycle At 100 Amperes Using CO₂</p>  <p>Continuous Welding</p>	<p>.023 To .045 in (0.6 To 1.1 mm) Hard Or Flux Cored Wires 60% Duty Cycle At 100 Amperes Using Mixed Gases</p>  <p>6 Minutes Welding 4 Minutes Resting</p> <p>SB1.1 8/93</p>
---	--	---

2-4. Volt-Ampere Curves

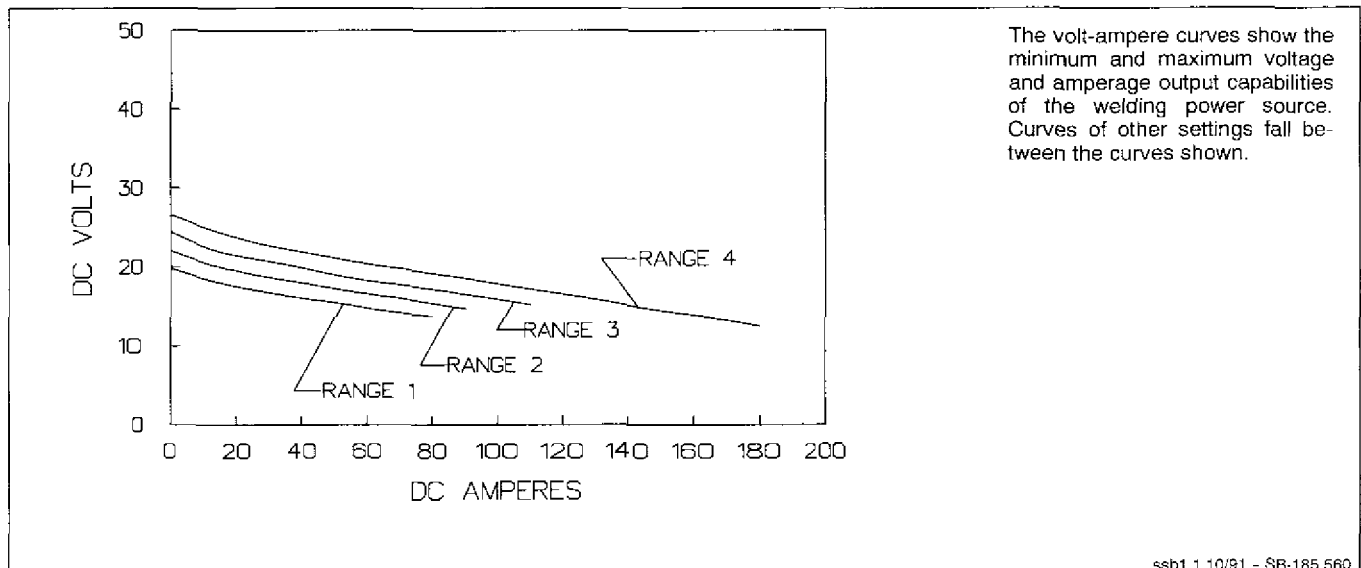

SECTION 3 - INSTALLATION

3-1. Selecting A Location

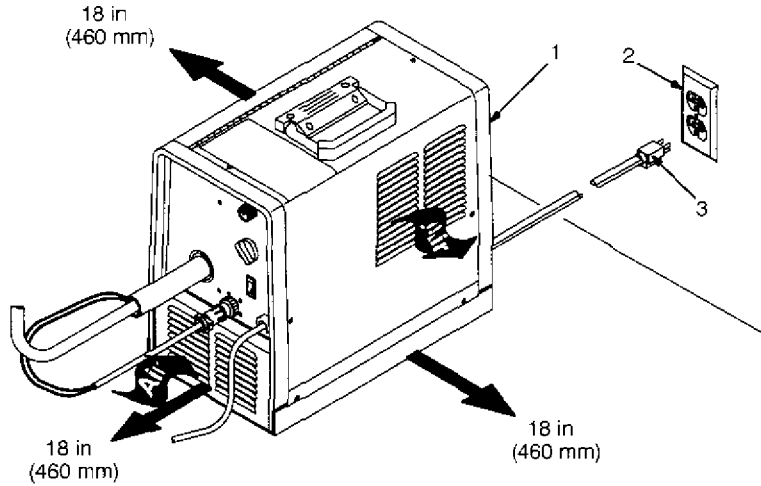

- 1 Rating Label
 - 2 Grounded Receptacle
- A 115 volt, 20 ampere individual branch circuit protected by time-delay fuses or circuit breaker is required.
- 3 Plug From Unit
- Select extension cord of 12 AWG for up to 75 ft (23 m) or 10 AWG for up to 140 ft (46 m).
- ▲ **Special installation may be required where gasoline or volatile liquids are present - see NEC Article 511 or CEC Section 20.**

Ref. 802 400 / Ref. 801 865

3-2. Installing Work Clamp



Tools Needed:

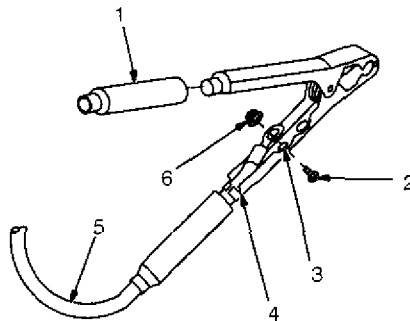
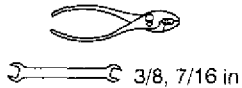

- 1 Insulator
 - 2 Bolt
 - 3 Smaller Hole
 - 4 Work Clamp Tabs
- Bend tabs around work cable.
- 5 Work Cable From Unit
 - 6 Nut

Ref. ST-025 190-D

3-3. Installing Welding Gun And Changing Polarity



☞ Follow wire manufacturer's recommendation.

Flux Cored Wires
(FCAW-Without Gas)

Solid Steel Or
Aluminum Wires
(GMAW-With Gas)

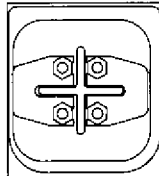

Straight Polarity
DCEN

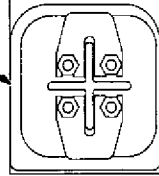

Reverse Polarity
DCEP

- 1 Drive Assembly
- 2 Gun Securing Nut
- 3 Gun End

Loosen securing nut. Insert gun end through opening until it bottoms against drive assembly. Tighten nut.

- 4 Gun Trigger Plug

Insert plug into receptacle, and tighten threaded collar.

- 5 Jumper Links

Place jumper links in position shown for desired polarity.

Close door.

Tools Needed:

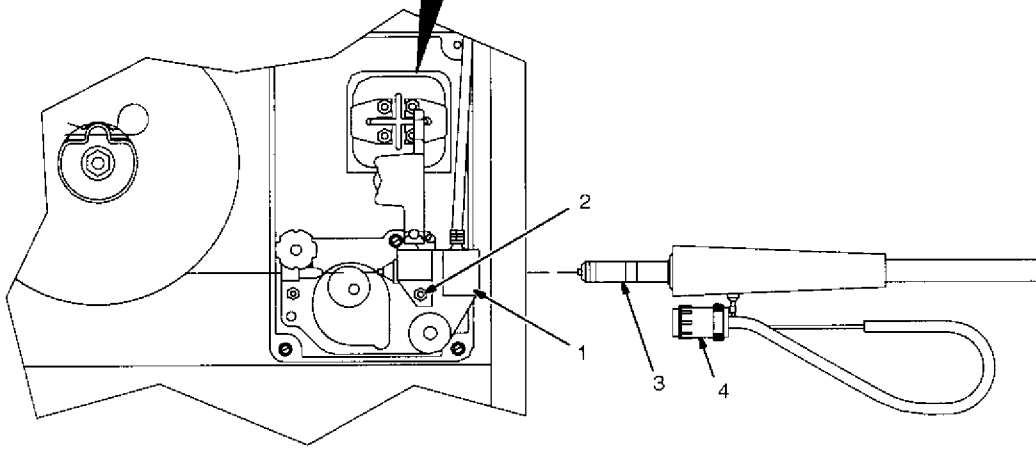
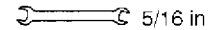

Ref. ST-801 868

3-4. Installing Gas Supply

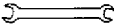

Tools Needed:
 5/8, 1-1/8 in

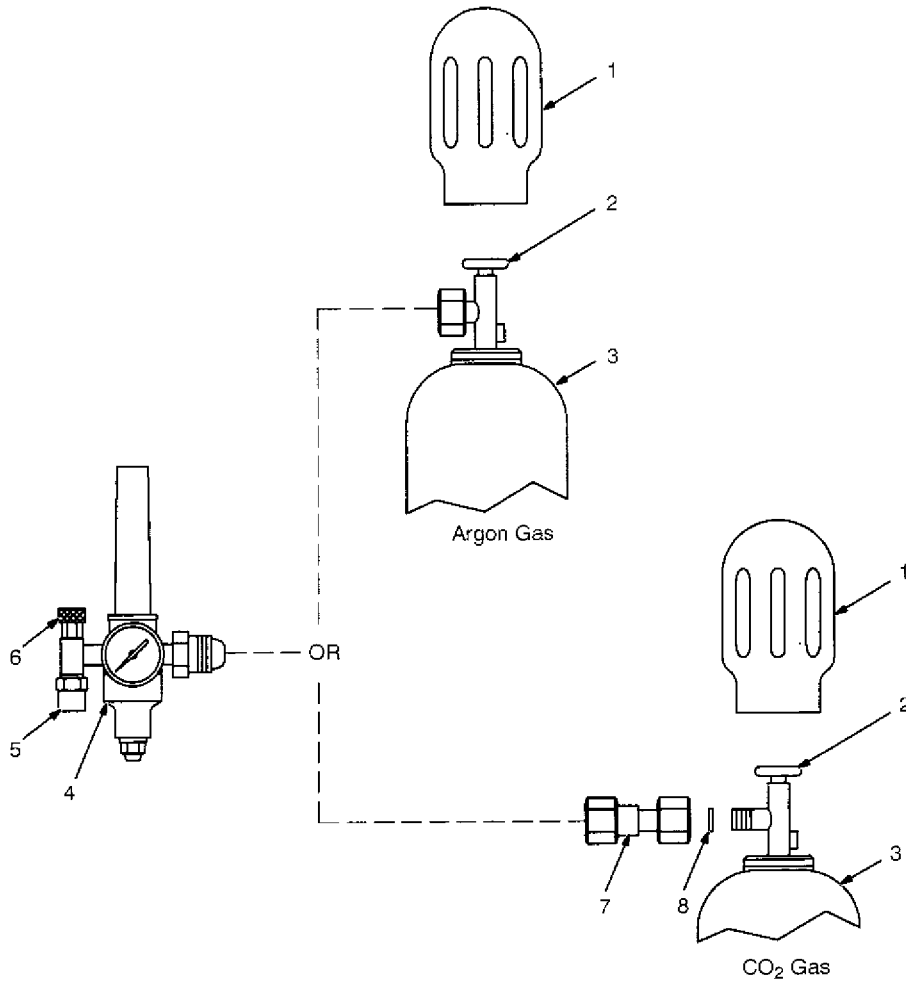

Obtain gas cylinder and chain to running gear, wall, or other stationary support so cylinder cannot fall and break off valve.

- 1 Cap
- 2 Cylinder Valve

Remove cap, stand to side of valve, and open valve slightly. Gas flow blows dust and dirt from valve. Close valve.

- 3 Cylinder
 - 4 Regulator/Flowmeter
- Install so face is vertical.

5 Gas Hose Connection Fitting has 5/8-18 right-hand threads. Install gas hose.

6 Flow Adjust
 Typical flow rate is 20 cfh (cubic feet per hour). Check wire manufacturer's recommended flow rate.

- 7 CO₂ Adapter
 - 8 O-Ring
- Install adapter with O-ring between regulator/flowmeter and CO₂ cylinder.

3-5. Installing Wire Spool And Adjusting Hub Tension

Standard Wire Spool

Standard Wire Reel

1 Lb Wire Spool

When a slight force is needed to turn spool, tension is set.

Tools Needed:

-
-
- 15/16 in

S-0499

3-6. Installing Drive Roll, Wire Guide And Threading Welding Wire



Tools Needed:



1 Drive roll

Choose correct drive roll for wire type, and align drive roll with flat spot on shaft. Slide drive roll onto shaft and secure with screw.

2 Inlet Wire Guide

Remove guide by pressing on barbed area or cutting off one end near housing and pulling it out of hole. Push new guide into hole. Push new guide into place.

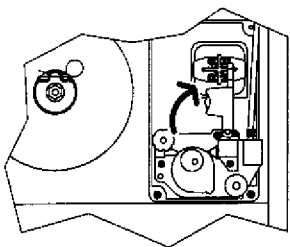
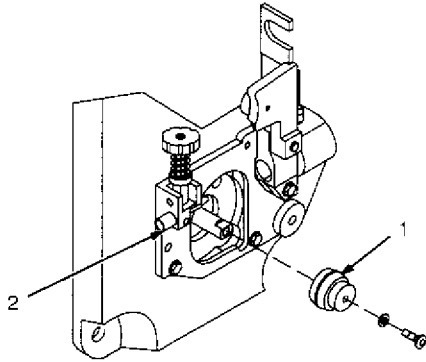

Open pressure assembly.

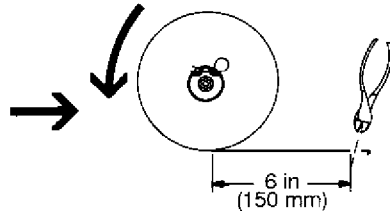

Pull and hold wire; cut off end.

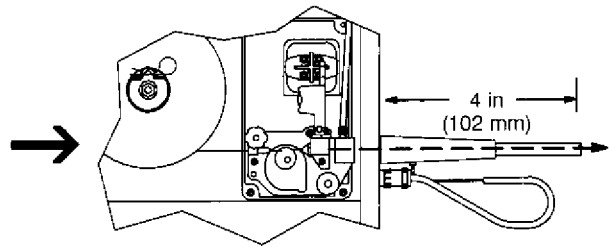

Push wire thru guides into gun; continue to hold wire.

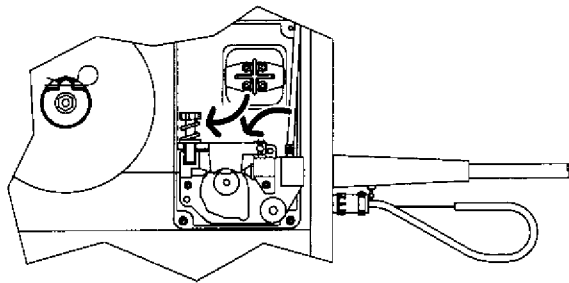

Close and tighten pressure assembly, and let go of wire.

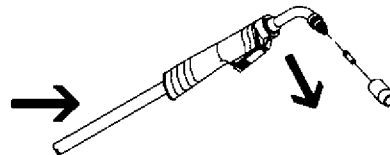

Remove gun nozzle and contact tip.

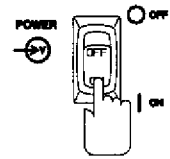

Turn power on.

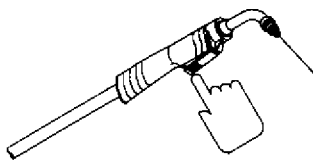

Press gun trigger until wire comes out of gun.

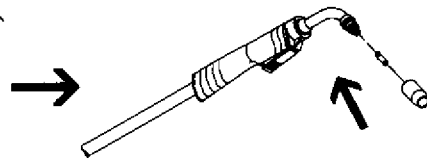

Reinstall contact tip, and nozzle.

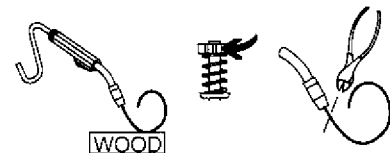

Feed wire to check drive roll pressure. Tighten knob enough to prevent slipping. Cut off wire. Close door.

3-7. Weld Parameter

Wire Type, Shielding Gas, And Flow Rate	Wire Diameter (inch)	Operator Controls	Material Thickness							
			3/16 in (4.8 mm)	1/8 in (3.2 mm)	14 ga	16 ga	18 ga	20 ga	22 ga	24 ga
E70S-6 CO ₂ 20 cfh+	.023	Voltage Tap*	4	4	3	2	2	1	1	--
		Wire Speed	60	55	50	50	45	40	40	--
	.030	Voltage Tap*	4	4	3	2	2	1	1	--
		Wire Speed	60	50	45	45	35	30	30	--
E70S-6 75% Argon 25% CO ₂ 20 cfh+	.023	Voltage Tap*	4	4	3	2	2	1	1	1
		Wire Speed	80	75	60	55	50	45	30	20
	.030	Voltage Tap*	4	4	3	2	2	1	1	--
		Wire Speed	70	65	60	55	50	45	30	--
E71T-GS Flux Core	.030	Voltage Tap*	4	4	3	2	1	--	--	--
		Wire Speed	50	40	30	25	20	--	--	--
	.035	Voltage Tap*	4	4	3	2	--	--	--	--
		Wire Speed	40	35	30	25	--	--	--	--
308L Stainless 90% Helium 7.5% Argon 2.5% CO ₂ 20 cfh	.023	Voltage Tap*	--	4	4	3	3	3	3	--
		Wire Speed	--	80	75	75	70	65	60	--
	.030	Voltage Tap*	--	4	4	3	3	3	3	--
		Wire Speed	--	75	70	70	65	60	50	--
5356AL 100% Argon 20 cfh	.030	Voltage Tap*	--	4	4	3	--	--	--	--
		Wire Speed	--	100	100	100	--	--	--	--
	.035	Voltage Tap*	--	4	4	4	--	--	--	--
		Wire Speed	--	100	100	100	--	--	--	--

*Do not change Voltage switch position while welding. Wire Speed value in Table is a starting value only, and Wire Speed control setting can be fine tuned during welding.

SECTION 4 - OPERATION

4-1. Controls

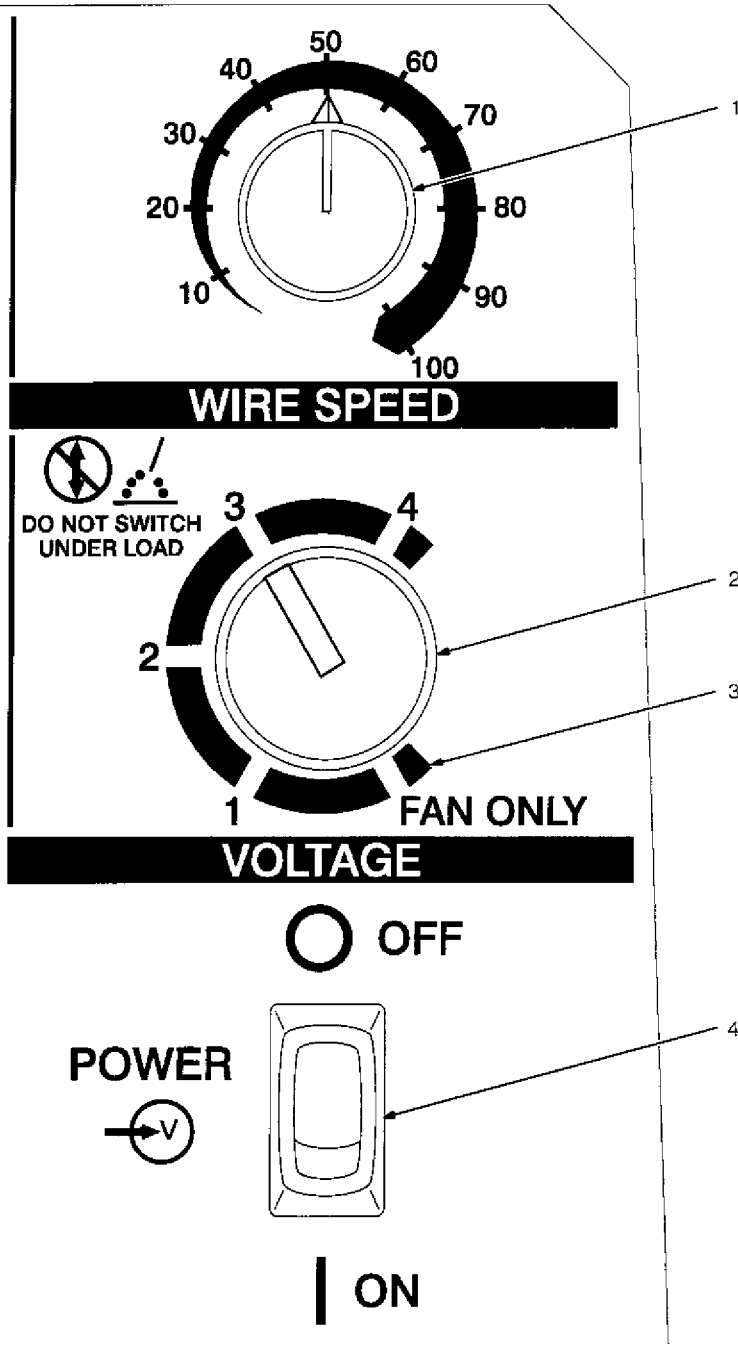

1 Wire Speed Control

Use control to select a wire feed speed. As Voltage switch setting increases, wire speed range also increases (see weld setting label in welding power source).

2 Voltage Switch (5 Position)

Switch must "click" into detent position 1, 2, 3, or 4 for proper contact.

The higher the selected number, the thicker the material that can be welded (see weld setting label in welding power source). Do not switch under load.

3 Voltage Switch - Fan Only Position





In Fan Only position, fan runs but there is no weld output.

4 Power Switch

Ref. ST-186 198

SECTION 5 - MAINTENANCE & TROUBLESHOOTING

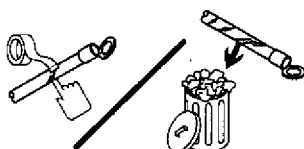
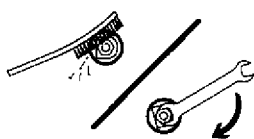
5-1. Routine Maintenance

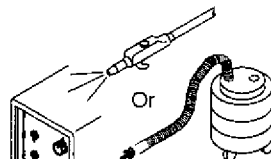
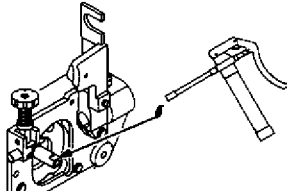
		<p>▲ Disconnect power before maintaining.</p>	
<p> 3 Months</p>			
<p>Replace unreadable labels.</p>		<p>Repair or replace cracked weld cable.</p>	
		<p>Clean and tighten weld terminals.</p>	
<p> 6 Months</p>			
<p>Blow out or vacuum inside. during heavy service, clean monthly.</p>		<p>Remove drive roll and apply light coat of oil or grease to drive motor shaft.</p>	

5-2. Drive Motor Fuse F1

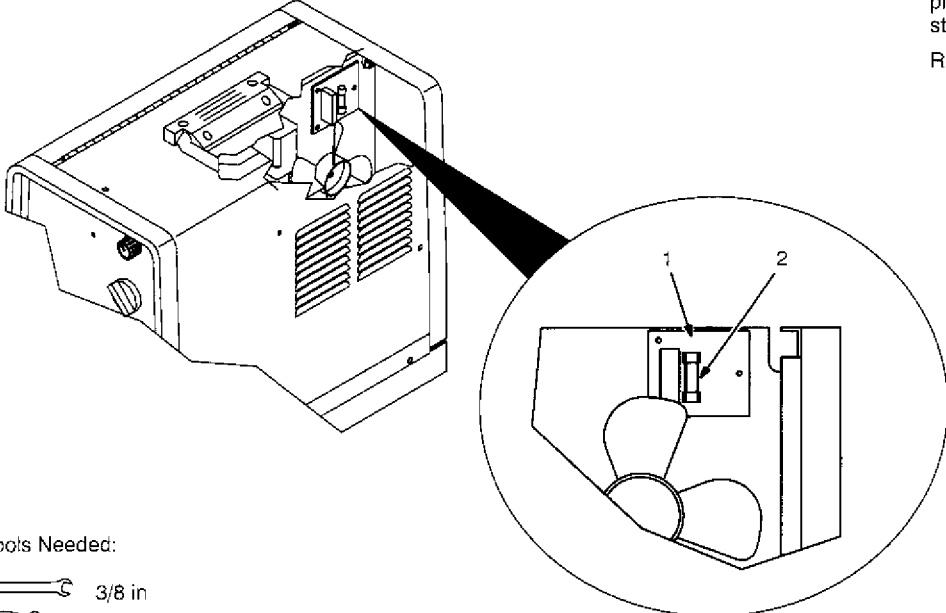
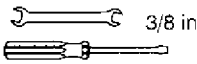
		<p>▲ Turn Off power, unlatch door and remove wrapper.</p> <ol style="list-style-type: none"> 1 Circuit Board PC1 2 Fuse F1 (See Parts List For Rating) <p>If drive motor is inoperative, pull fuse from fuse holder on PC1. Replace fuse if necessary. To reinstall, push fuse into fuse holder.</p> <p>Reinstall wrapper, and latch door.</p>
		
<p>Tools Needed:</p>  <p>3/8 in</p>		

ST-801 867

5-3. Short Circuit Shutdown

If contact tip is shorted and sticks to workpiece, the unit shuts down, but fan runs. To resume operation, release gun trigger, turn Off unit, and remove contact tip from workpiece. Check contact tip and replace if damaged. Turn On unit to continue operation.

5-4. Cleaning Or Repairing Drive Assembly

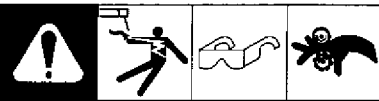

Tools Needed:

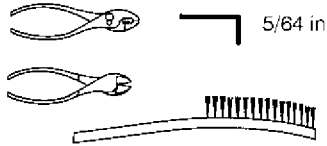

▲ **Turn Off power before cleaning or repairing drive assembly.**

1 Wire Spool

2 Nozzle

Cut welding wire off at nozzle. Retract wire onto spool and secure.

3 Pressure Roll Arm

4 Cotter Pin

5 Pin

6 Screw

7 Bearing

Remove bearing. Install new bearing and secure with screw. Reinstall arm onto pin and secure with cotter pin.

8 Screw

9 Drive Roll

Remove drive roll.

Align drive roll with flat spot on shaft. Slide drive roll onto shaft and secure with screw.

10 Wire Inlet Guide

Remove guide by pressing on barbed area or cutting off one end near housing and pulling it out of hole. Push new guide into hole from rear until it snaps in place.

Close door.

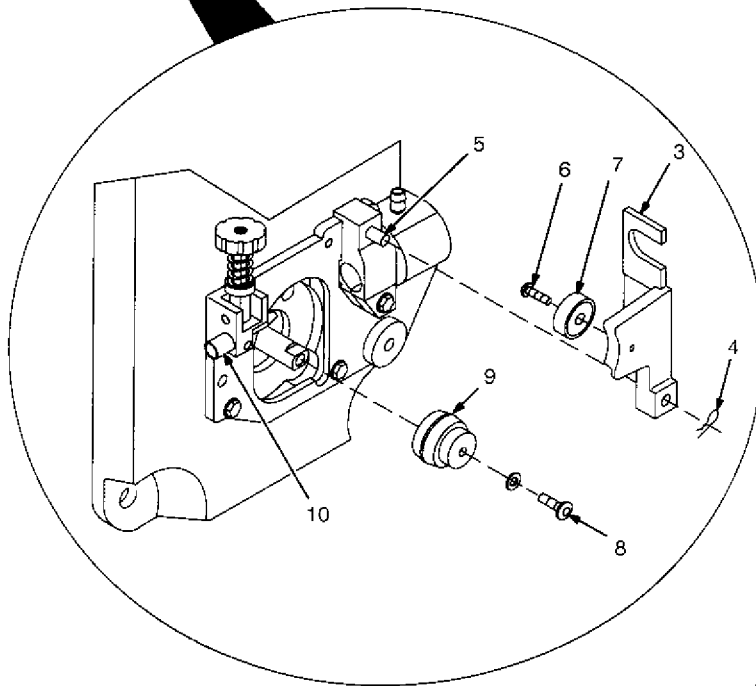
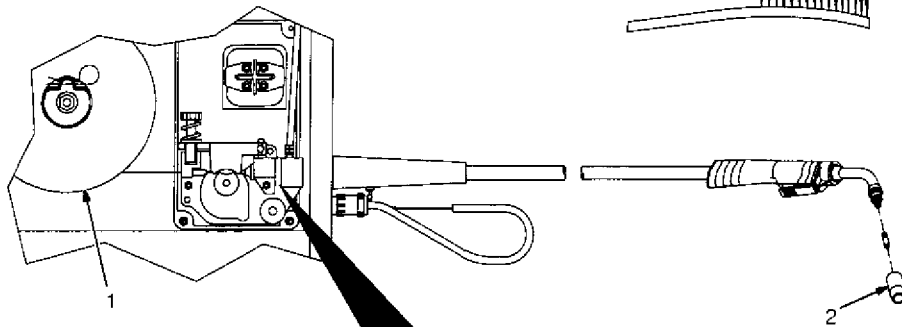

Ref. ST-801 668 / Ref. ST-801 672 / Ref. 802 399-A

5-5. Replacing Gun Contact Tip



▲ Turn Off power before replacing contact tip.

- 1 Nozzle
- 2 Contact Tip

Cut off welding wire at contact tip.
Remove nozzle.

Remove contact tip and install new contact tip.
Reinstall nozzle.

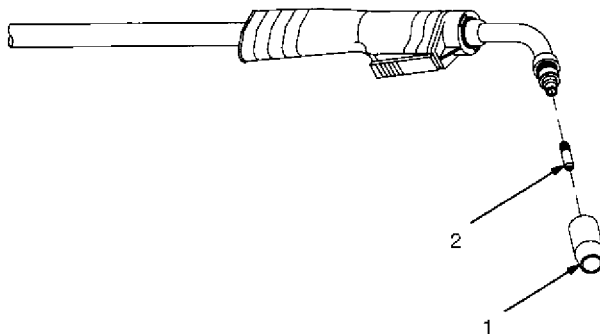

Tools Needed:

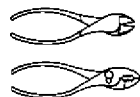

Ref. 802 399-A

5-6. Cleaning Or Replacing Gun Liner



▲ Disconnect gun from unit.

Tools Needed:

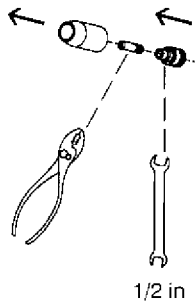
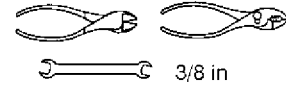

1/2 in

Head Tube

Remove nozzle, contact tip, adapter, gas diffuser, and wire outlet guide.

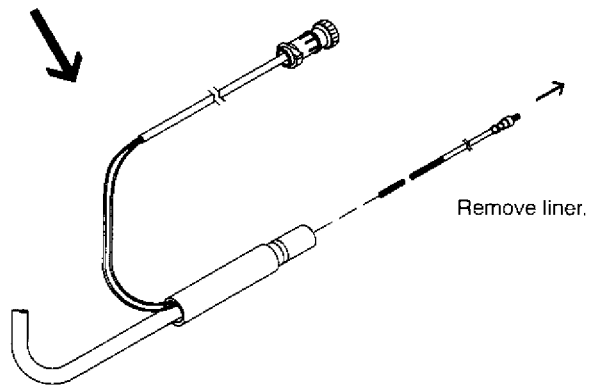

Remove liner.

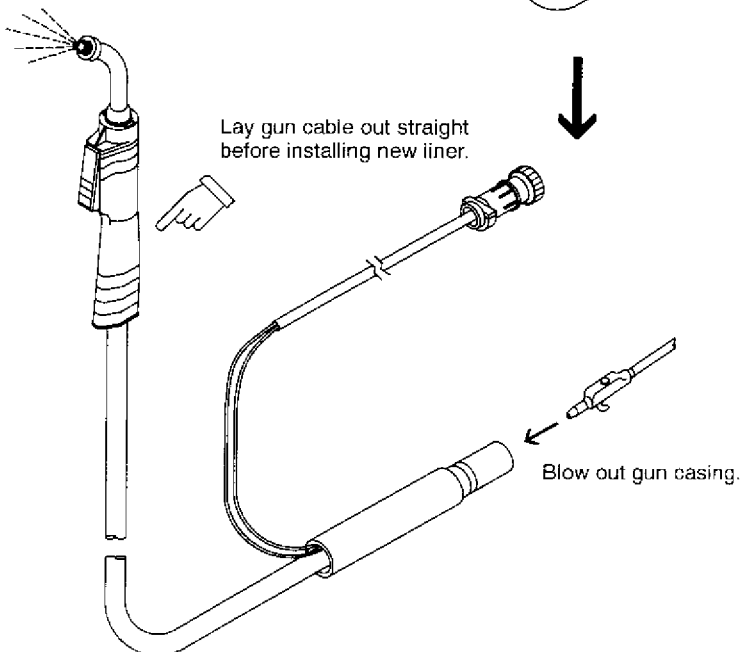

Lay gun cable out straight before installing new liner.

Blow out gun casing.

To Reassemble Gun:

Insert new liner.



Install wire outlet guide so that 1/8 in (3 mm) of liner sticks out. Hand tighten outlet guide, and then tighten two full turns more.

Cut liner off so that 3/4 in (19 mm) sticks out of head tube.

Install gas diffuser, adapter, contact tip, and nozzle.

Ref. ST-802 399-A



5-7. Replacing Switch And/Or Head Tube

▲ Disconnect gun first.

- 1 Remove handle locking nut.
- 2 Remove switch housing. Note: If installing new switch, push switch lead connectors onto terminal of new switch (polarity is not important). Install switch back into handle, and secure with handle locking nut. If replacing head tube, continue to end of figure.
- 3 Slide handle.
- 4 Secure head tube in vice.
- 5 Loosen jam nut. Remove from vice and turn head tube out by hand.
- 6 Install existing shock washer onto new head tube. Hand-tighten head tube into connector cable.
- 7 Place head tube in vice and tighten until nuts are tight.
- 8 Remove from vice. Reposition handle and install switch housing. Secure with handle locking nut.

Tools Needed:

-  3/4 in
- 

Ref. ST-800 795-C

5-8. Troubleshooting Table



Trouble	Remedy
No weld output; wire does not feed; fan does not run.	Secure power cord plug in receptacle (see Section 3-1).
	Replace building line fuse or reset circuit breaker if open.
	Secure gun trigger plug in receptacle (see Section 3-3).
	Place Power switch in On position (see Section 4-1).
No weld output; wire does not feed; fan motor continues to run.	Check Voltage control knob. Switch must "click" into detent position 1, 2, 3, or 4 for proper contact (see Section 4-1).
	Thermostat TP1 open (overheating). Allow fan to run; thermostat closes when unit has cooled (see Section 2-2).
	Check and replace motor fuse F1, if necessary (see Section 5-2).
	Have Factory Authorized Service Agent check all board connections and shut down PC1 board.
No weld output; wire feeds.	Connect work clamp to get good metal to metal contact.
	Replace contact tip (see gun Owner's Manual).
	Check for proper connections at polarity changeover board (see Section 3-3).
Low weld output.	Connect unit to proper input voltage or check for low line voltage.
	Place voltage switch in desired position (see Section 4-1).
Electrode wire feeding stops during welding.	Straighten gun cable and/or replace damaged parts (see gun Owner's Manual).
	Adjust drive roll pressure (see Section 3-6).
	Change to proper drive roll groove (see Section 3-6).
	Readjust hub tension (see Section 3-5).
	Replace contact tip if blocked (see Section 5-5).
	Clean or replace wire inlet guide or liner if dirty or plugged (see Section 5-4 or Section 5-6).
	Replace drive roll or pressure bearing if worn or slipping (see Section 5-4).
	Secure gun trigger plug in receptacle or repair leads, or replace trigger switch (see Section 3-3).
	Check motor fuse F1, and replace if necessary (see Section 5-2).
Check and clear any restrictions at drive assembly and liner (see Section 5-4 or Section 5-6).	Have nearest Factory Authorized Service Agent check drive motor.

SECTION 7 - MIG WELDING (GMAW) GUIDELINES



7-1. Typical MIG Process Connections

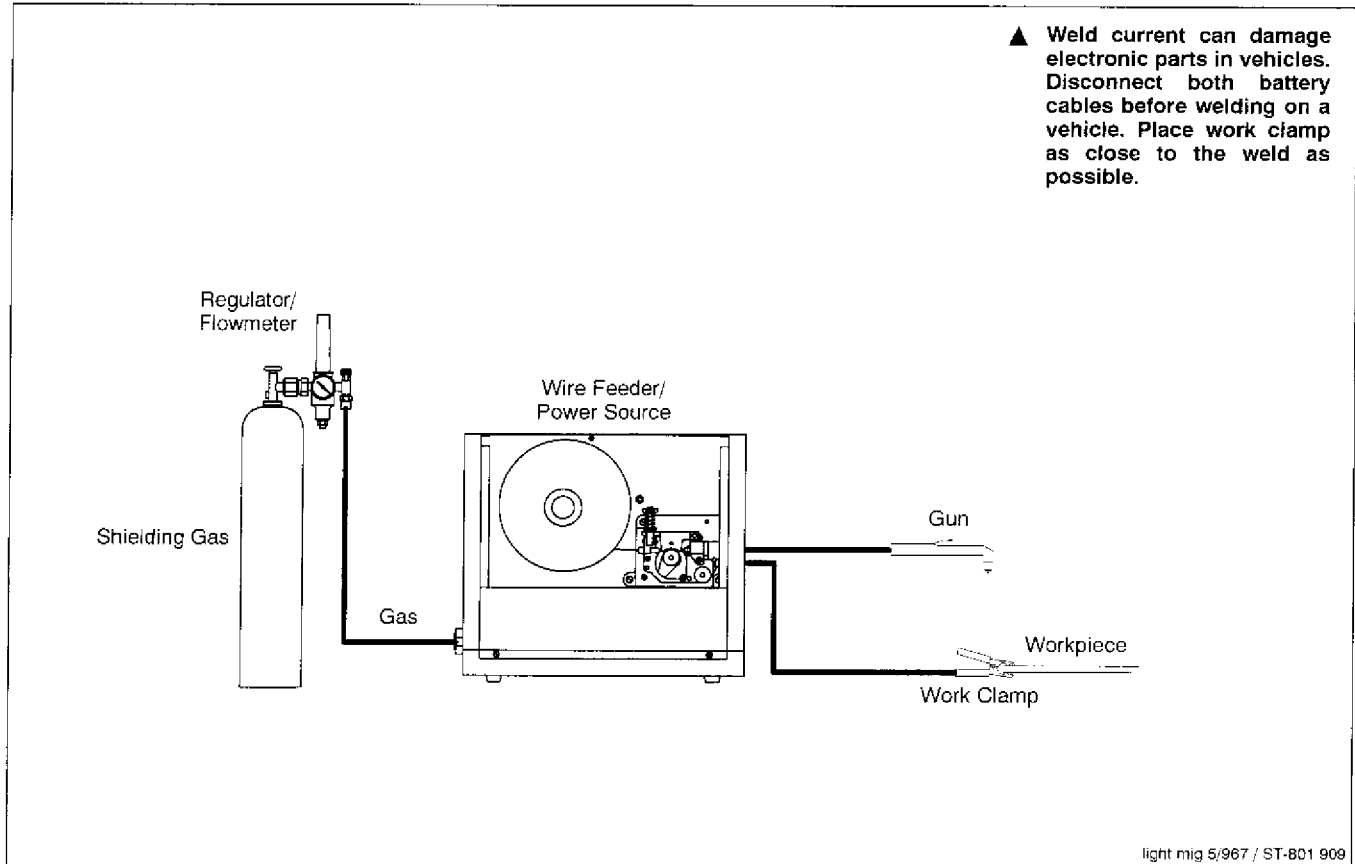

7-2. Typical MIG Process Control Settings

NOTE

These settings are guidelines only. Material and wire type, joint design, fitup, position, shielding gas, etc. affect settings. Test welds to be sure they comply to specifications.

Material thickness determines weld parameters.

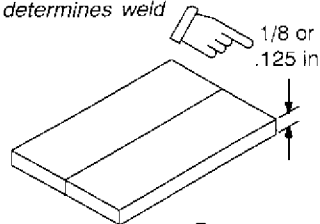

Convert Material Thickness to Amperage (A)

.001 in = 1 ampere
.125 in = 125 A

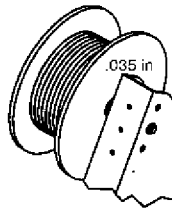

Wire Size	Amperage Range
.023 in	30 - 90 A
.030 in	40 - 145 A
.035 in	50 - 180 A

Select Wire Size

Wire Size	Recommendation	Wire Speed (Approx.)
.023 in	3.5 in per ampere	$3.5 \times 125 \text{ A} = 437 \text{ ipm}$
.030 in	2 in per ampere	$2 \times 125 \text{ A} = 250 \text{ ipm}$
.035 in	1.6 in per ampere	$1.6 \times 125 \text{ A} = 200 \text{ ipm}$

Select Wire Speed (Amperage)

125 A based on 1/8 in material thickness

ipm = inch per minute

Low voltage: wire stubs into work
High voltage: arc is unstable (spatter)
Set voltage midway between high/low voltage.

Select Voltage

Wire speed (amperage) controls weld penetration (wire speed = burn-off rate)

Voltage controls height and width of weld bead.

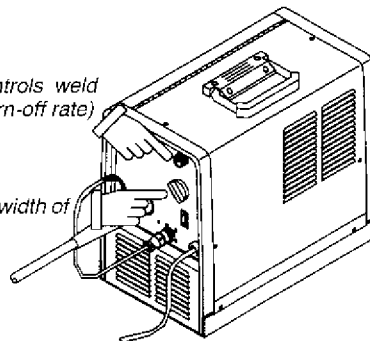

Ref. ST-801 865

7-3. Holding And Positioning Welding Gun

NOTE

Welding wire is energized when gun trigger is pressed. Before lowering helmet and pressing trigger, be sure wire is no more than 1/2 in (13 mm) past end of nozzle, and tip of wire is positioned correctly on seam.

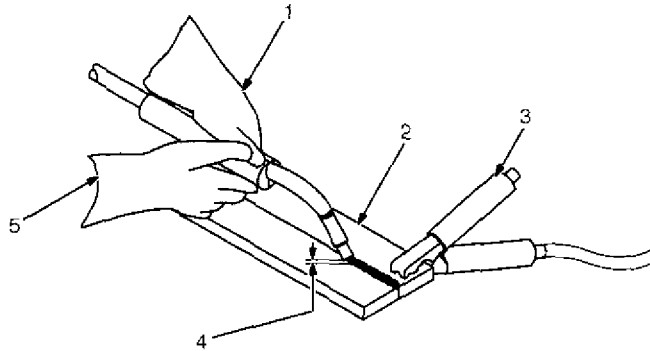

- 1 Hold Gun and Control Gun Trigger
- 2 Workpiece
- 3 Work Clamp
- 4 Electrode Extension (Stickout) 1/4 to 1/2 in (6 To 13 mm)
- 5 Cradle Gun and Rest Hand on Workpiece

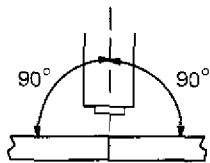

End View Of Work Angle

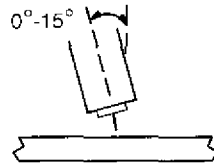

Side View Of Gun Angle

GROOVE WELDS

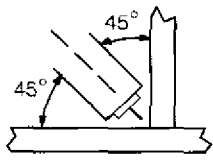

End View Of Work Angle

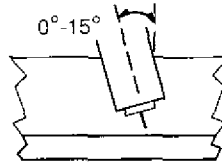

Side View Of Gun Angle

FILLET WELDS

S-0421-A

7-4. Conditions That Affect Weld Bead Shape

NOTE

Weld bead shape depends on gun angle, direction of travel, electrode extension (stickout), travel speed, thickness of base metal, wire feed speed (weld current), and voltage.

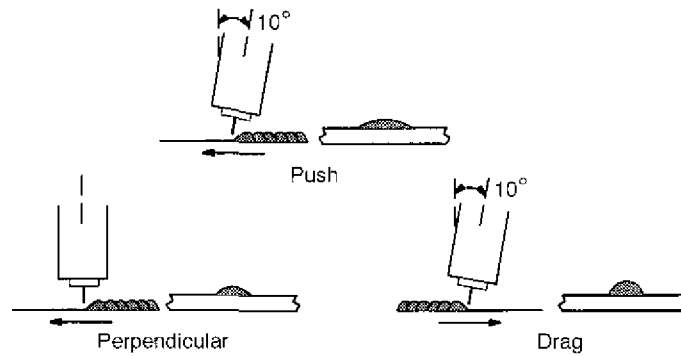

GUN ANGLES AND WELD BEAD PROFILES

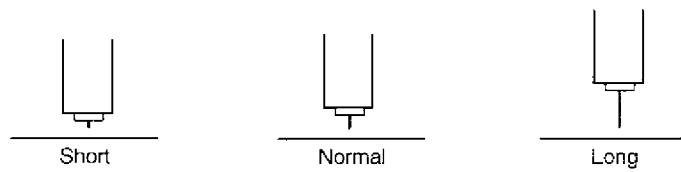

ELECTRODE EXTENSIONS (STICKOUT)

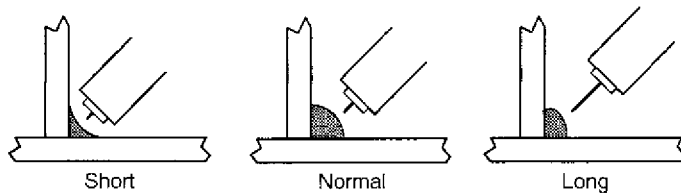

FILLET WELD ELECTRODE EXTENSIONS (STICKOUT)

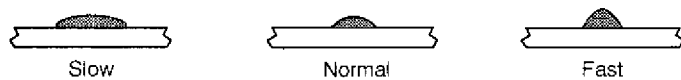

GUN TRAVEL SPEED

S-0634

7-5. Gun Movement During Welding

NOTE

Normally, a single stringer bead is satisfactory for most narrow groove weld joints; however, for wide groove weld joints or bridging across gaps, a weave bead or multiple stringer beads works better.

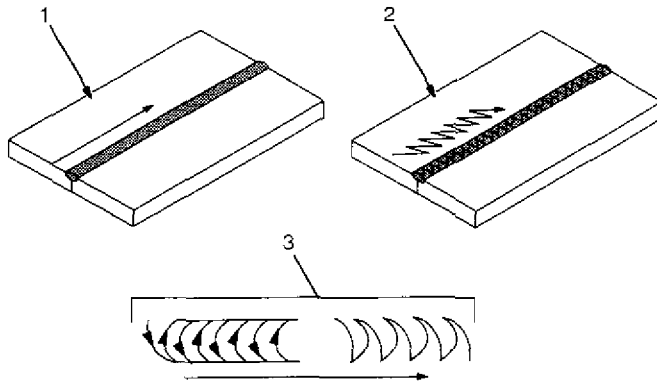

- 1 Stringer Bead - Steady Movement Along Seam
- 2 Weave Bead - Side To Side Movement Along Seam
- 3 Weave Patterns

Use weave patterns to cover a wide area in one pass of the electrode.

S-0054-A

7-6. Poor Weld Bead Characteristics

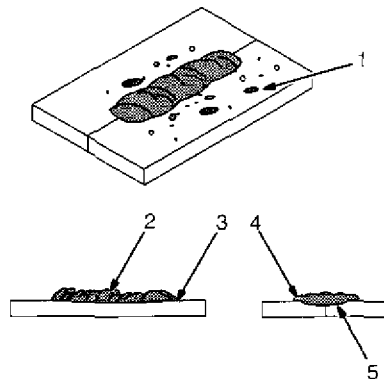

- 1 Large Spatter Deposits
- 2 Rough, Uneven Bead
- 3 Slight Crater During Welding
- 4 Bad Overlap
- 5 Poor Penetration

S-0053-A

7-7. Good Weld Bead Characteristics

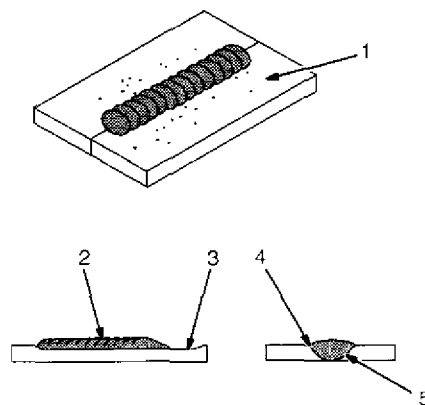

- 1 Fine Spatter
- 2 Uniform Bead
- 3 Moderate Crater During Welding

Weld a new bead or layer for each 1/8 in (3.2 mm) thickness in metals being welded.

- 4 No Overlap
- 5 Good Penetration into Base Metal

S-0052-B

7-8. Troubleshooting - Excessive Spatter

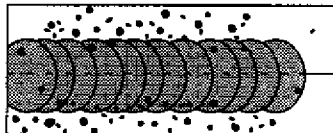

Excessive Spatter - scattering of molten metal particles that cool to solid form near weld bead.

S-0636

Possible Causes	Corrective Actions
Wire feed speed too high.	Select lower wire feed speed.
Voltage too high.	Select lower voltage range.
Electrode extension (stickout) too long.	Use shorter electrode extension (stickout).
Workpiece dirty.	Remove all grease, oil, moisture, rust, paint, undercoating, and dirt from work surface before welding.
Insufficient shielding gas at welding arc.	Increase flow of shielding gas at regulator/flowmeter and/or prevent drafts near welding arc.
Dirty welding wire.	Use clean, dry welding wire.
	Eliminate pickup of oil or lubricant on welding wire from feeder or liner.

7-9. Troubleshooting - Porosity

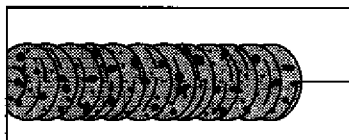

Porosity - small cavities or holes resulting from gas pockets in weld metal.

S-0635

Possible Causes	Corrective Actions
Insufficient shielding gas at welding arc.	Increase flow of shielding gas at regulator/flowmeter and/or prevent drafts near welding arc.
	Remove spatter from gun nozzle.
	Check gas hoses for leaks.
	Place nozzle 1/4 to 1/2 in (6-13 mm) from workpiece.
	Hold gun near bead at end of weld until molten metal solidifies.
Wrong gas.	Use welding grade shielding gas; change to different gas.
Dirty welding wire.	Use clean, dry welding wire.
	Eliminate pick up of oil or lubricant on welding wire from feeder or liner.
Workpiece dirty.	Remove all grease, oil, moisture, rust, paint, coatings, and dirt from work surface before welding.
	Use a more highly deoxidizing welding wire (contact supplier).
Welding wire extends too far out of nozzle.	Be sure welding wire extends not more than 1/2 in (13 mm) beyond nozzle.

7-10. Troubleshooting - Excessive Penetration

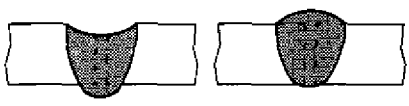
		<p>Excessive Penetration - weld metal melting through base metal and hanging underneath weld.</p>
		S-0639
Possible Causes	Corrective Actions	
Excessive heat input.	Select lower voltage range and reduce wire feed speed.	
	Increase travel speed.	

7-11. Troubleshooting - Lack Of Penetration

		<p>Lack Of Penetration - shallow fusion between weld metal and base metal.</p>
		S-0638
Possible Causes	Corrective Actions	
Improper joint preparation.	Material too thick. Joint preparation and design must provide access to bottom of groove while maintaining proper welding wire extension and arc characteristics.	
Improper weld technique.	Maintain normal gun angle of 0 to 15 degrees to achieve maximum penetration.	
	Keep arc on leading edge of weld puddle.	
	Be sure welding wire extends not more than 1/2 in (13 mm) beyond nozzle.	
Insufficient heat input.	Select higher wire feed speed and/or select higher voltage range.	
	Reduce travel speed.	

7-12. Troubleshooting - Incomplete Fusion

		<p>Incomplete Fusion - failure of weld metal to fuse completely with base metal or a preceding weld bead.</p>
		S-0637
Possible Causes	Corrective Actions	
Workpiece dirty.	Remove all grease, oil, moisture, rust, paint, undercoating, and dirt from work surface before welding.	
Insufficient heat input.	Select higher voltage range and/or adjust wire feed speed.	
Improper welding technique.	Place stringer bead in proper location(s) at joint during welding.	
	Adjust work angle or widen groove to access bottom during welding.	
	Momentarily hold arc on groove side walls when using weaving technique.	
	Keep arc on leading edge of weld puddle.	
	Use correct gun angle of 0 to 15 degrees.	

7-13. Troubleshooting - Burn-Through

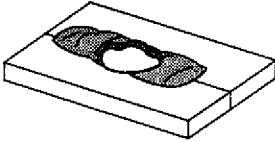
		<p>Burn-Through - weld metal melting completely through base metal resulting in holes where no metal remains.</p> <p style="text-align: right;">S-0640</p>
Possible Causes	Corrective Actions	
Excessive heat input.	Select lower voltage range and reduce wire feed speed.	
	Increase and/or maintain steady travel speed.	

7-14. Troubleshooting - Waviness Of Bead

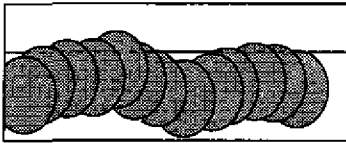
		<p>Waviness Of Bead - weld metal that is not parallel and does not cover joint formed by base metal.</p> <p style="text-align: right;">S-0641</p>
Possible Causes	Corrective Actions	
Welding wire extends too far out of nozzle.	Be sure welding wire extends not more than 1/2 in (13 mm) beyond nozzle.	
Unsteady hand.	Support hand on solid surface or use two hands.	

7-15. Troubleshooting - Distortion

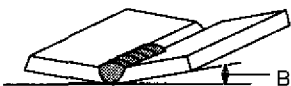
 <p style="text-align: center;">Base metal moves in the direction of the weld bead.</p>		<p>Distortion - contraction of weld metal during welding that forces base metal to move.</p> <p style="text-align: right;">S-0642</p>
Possible Causes	Corrective Actions	
Excessive heat input.	Use restraint (clamp) to hold base metal in position.	
	Make tack welds along joint before starting welding operation.	
	Select lower voltage range and/or reduce wire feed speed.	
	increase travel speed.	
	Weld in small segments and allow cooling between welds.	

7-16. Common MIG Shielding Gases

This is a general chart for common gases and where they are used. Many different combinations (mixtures) of shielding gases have been developed over the years. The most commonly used shielding gases are listed in the following table.

Gas	Application			
	Spray Arc Steel	Short Circuiting Steel	Short Circuiting Stainless Steel	Short Circuiting Aluminum
Argon				All Positions
Argon + 25% CO ₂	Flat & Horizontal ¹ Fillet	All Positions	All Positions ²	
CO ₂	Flat & Horizontal ¹ Fillet	All Positions		
Tri-Mix ³			All Positions	

1 Globular Transfer

2 Single Pass Welding Only

3 90% HE + 7-1/2% AR + 2-1/2% CO₂

SECTION 8 - PARTS LIST

☞ Hardware is common and not available unless listed.

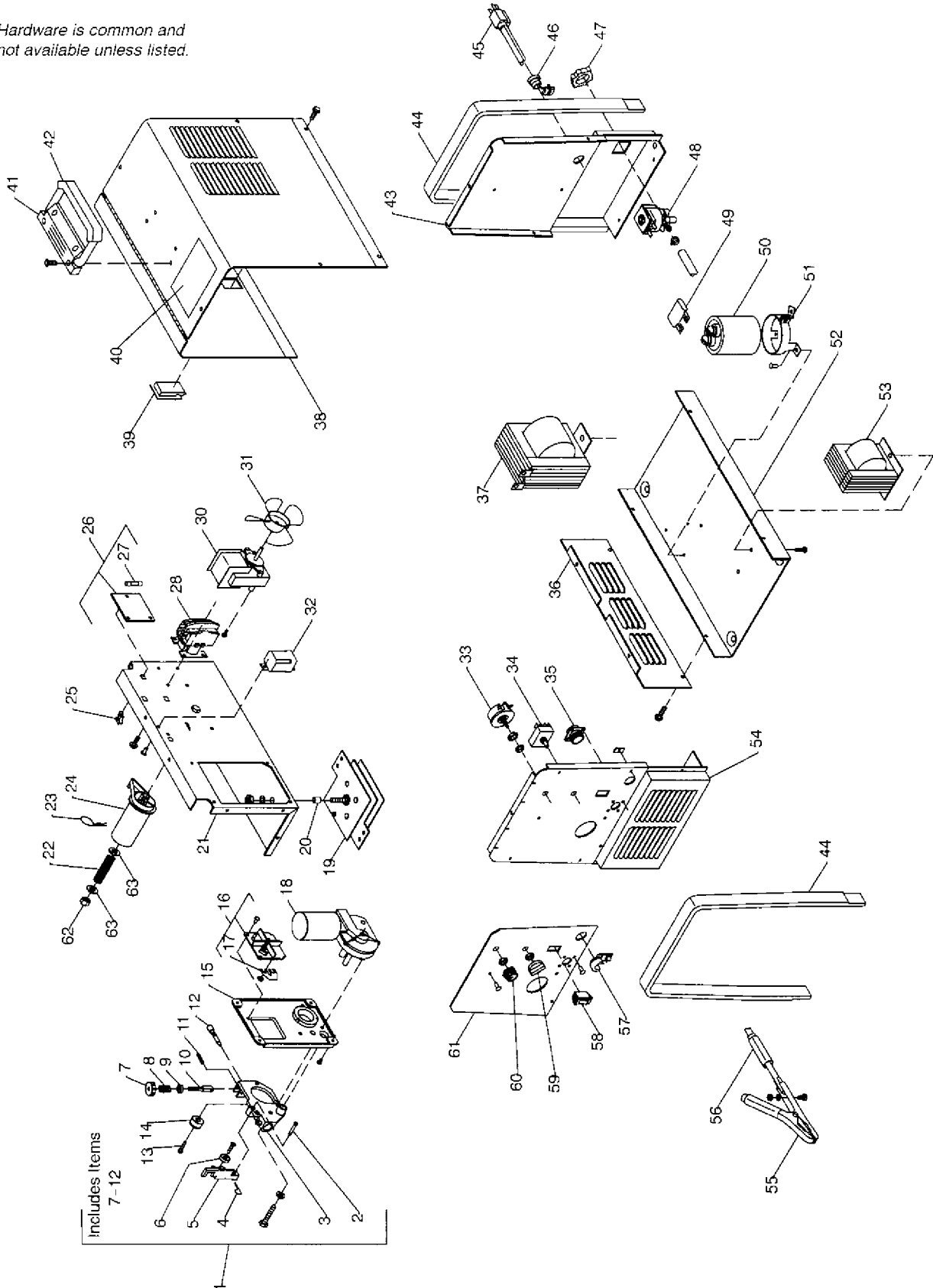

Figure 8-1. Complete Assembly

ST-801 863-B

Item No.	Dia. Mkgs.	Part No.	Description	Quantity
1		126 838	DRIVE ASSEMBLY, wire (consisting of)	1
2		090 416	PIN, hinge	1
3		124 817	HOUSING, wire drive	1
4		151 828	PIN, cotter hair .054 x .750	1
5		112 031	LEVER, pressure roll	1
6		090 443	BEARING, ball rdl sgl row .866 OD x .447 width x .315 bore (consisting of)	1
		111 622	SPACER, bearing .196 ID x .310 OD x .500 collar	1
7		092 237	KNOB, adj tension	1
8		090 415	SPRING, cprsn .720 OD x .070 wire x 1.250	1
9		085 244	WASHER, cupped stl .328 ID x .812 OD x .125	1
10		085 242	FASTENER, pinned	1
11		010 224	PIN, spring CS .187 x 1.000	1
12		058 549	GUIDE, wire inlet 1/16	1
13		174 609	SCREW, M-.7 x 12 sochd	1
14		165 603	ROLL, drive vk groove .030-.035	1
15		186 205	HOUSING, drive motor	1
16		122 385	TERMINAL ASSEMBLY, changeover (consisting of)	1
17		174 504	LINK, jumper	2
18		186 212	MOTOR, gear 24VDC	1
19	SR1	119 264	RECTIFIER	1
20		175 994	SPACER, nylon .750 OD x .390 ID	1
21		186 255	BAFFLE, center	1
22		073 355	SPRING, cprsn	1
23		111 998	PIN, cotter	1
24		111 929	HUB, spool	1
25		134 201	STAND-OFF SUPPORT, PC card	7
26	PC1	119 539	CIRCUIT CARD, shutdown (consisting of)	1
27	F1	073 426	FUSE, mintr gl slo-blo 5A 250V	1
		165 745	CONNECTOR & SOCKETS	1
28	CR2	129 696	CONTACTOR, def prp 25A 1P 24V	1
30	FM	210 123	MOTOR, fan 115V 50/60Hz	1
31		005 656	BLADE, fan 6.000 4wg 30deg	1
32	CR1	006 393	RELAY, encl 24VAC DPDT	1
33	R1	186 207	RHEOSTAT, WW 25W 16 ohm	1
34	S2	409 477	SWITCH, rotary 25A 5pos	1
35		048 282	RECEPTACLE w/SOCKETS	1
36		147 560	PANEL, side lower	1
37	T1	210 000	TRANSFORMER, pwr main	1
38		+147 563	WRAPPER	1
39		089 899	LATCH	1
40		204 036	LABEL, warning general precautionary	1
41		126 415	CLAMP, saddle	1
42		126 416	HANDLE	1
43		147 462	PANEL, rear	1
44		146 753	BEZEL, front	2
45		147 545	CORD SET, 125V	1
46		111 443	BUSHING, strain relief .240/.510	1
47		605 227	NUT, .750-14	1
48	GS1	116 996	VALVE, 115VAC 2way	1
49		181 649	RESISTOR, WW fxd 40W 25 ohm	1
50	C1	186 311	CAPACITOR, elctft 91000uf 35VDC	1
51		108 105	CLAMP, capacitor	1
52		147 566	BASE	1
53	Z1	186 161	STABILIZER	1
54		147 461	PANEL, front	1
55		010 368	CLAMP, work	1

Item No.	Dia. Mkgs.	Part No.	Description	Quantity
----------	------------	----------	-------------	----------

Figure 8-1. Complete Assembly

56		026 843	INSULATOR, vinyl	1
57		111 644	BUSHING, strain relief .370/.430 ID	1
58	S1	111 997	SWITCH, rocker SPST 10A 250VAC	1
59		186 217	KNOB, pointer 1.250dia	1
60		097 922	KNOB, pointer .875dia	1
61			NAMEPLATE, (order by model and serial number)	1
		183 312	ADAPTER RING, wire spool	1
		135 615	BUSHING, nylon	2
		010 287	WRENCH, hex	1
62		010 909	NUT, 375-16	1
63		010 910	WASHER, flat .406 ID x .812 OD	2

*Recommend Spare Parts.

+When ordering a component originally displaying a precautionary label, the label should also be ordered.

To maintain the factory original performance of your equipment, use only Manufacturer's Suggested Replacement Parts. Model and serial number required when ordering parts from your local distributor.

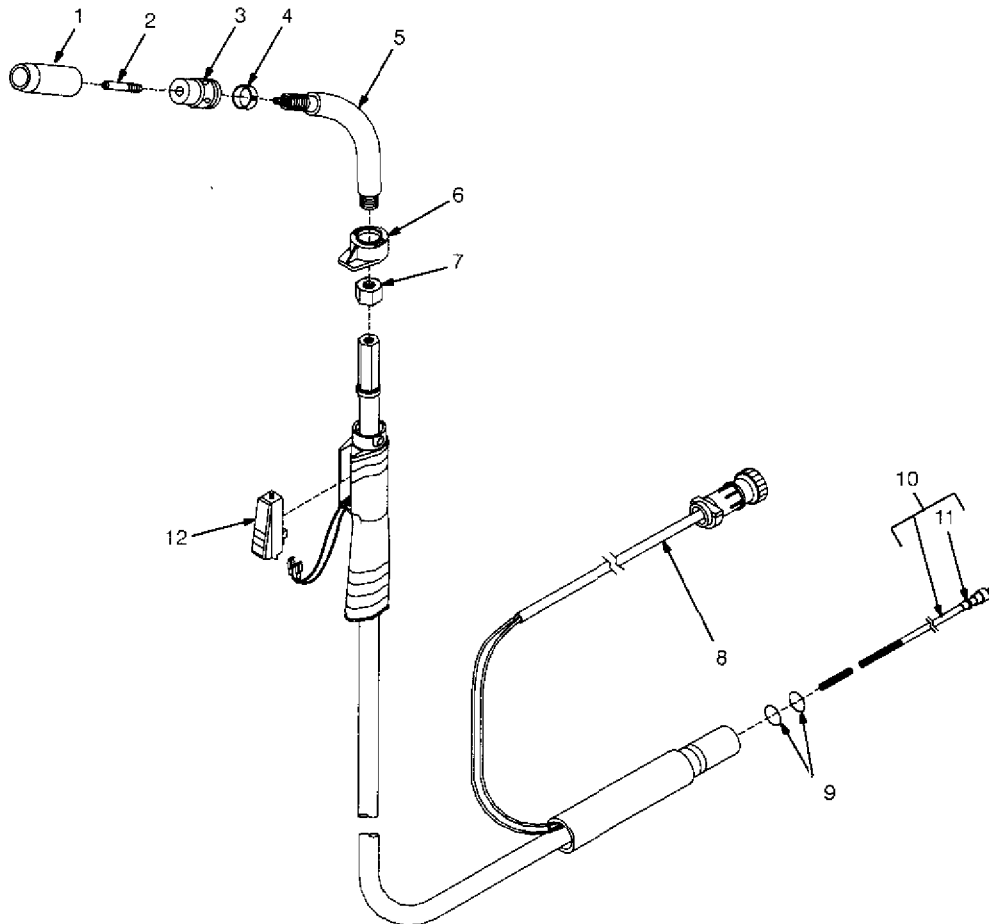

Figure 8-2.M-10 Gun

ST-802 388-A

Item No.	Part No.	Description	Quantity
Figure 8-2. M-10 Gun			
1	169 715	NOZZLE, slip type .500 orf flush	1
2	◆087 299	TIP, contact scr .023 wire x 1.125	
2	◆000 067	TIP, contact scr .030 wire x 1.125	
2	◆000 068	TIP, contact scr .035 wire x 1.125	
2	◆000 069	TIP, contact scr .045 wire x 1.125	
3	169 716	ADAPTER, contact tip	1
4	170 470	RING, retaining	1
5	169 718	TUBE, head	1
6	169 738	NUT, locking handle	1
7	194 524	NUT, jam	1
8	180 433	CORD, trigger assembly	1
9	079 974	O-RING, .500 ID x .103CS rbr	2
10	◆194 010	LINER, monocoil .023/.025 wire x 15ft (consisting of)	1
10	◆194 011	LINER, monocoil .030/.035 wire x 15ft (consisting of)	1
10	◆194 012	LINER, monocoil .035/.045 wire x 15ft (consisting of)	1
11	079 975	O-RING, .187 ID x .103CS rbr	1
12	196 255	SWITCH, trigger	1

◆OPTIONAL

To maintain the factory original performance of your equipment, use only Manufacturer's Suggested Replacement Parts. Model and serial number required when ordering parts from your local distributor.



Millermatic® 130 XP

Arc Welding Power Source, Wire Feeder and Gun Package

Processes

-  MIG (GMAW) Welding
-  Flux Cored (FCAW) Welding

Welds materials up to 3/16 in (4.8 mm) thick



includes Miller M-10 MIG Gun

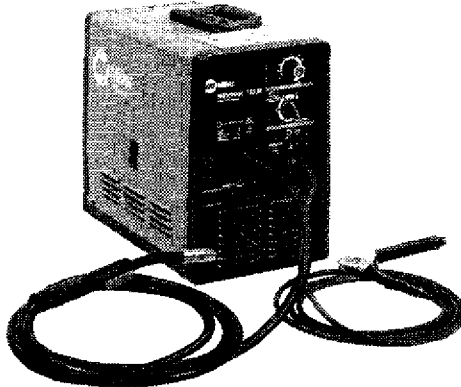

Customers trust Miller for products with durability and performance. They get that plus a reliable, easy to operate welder in the Millermatic® 130 XP. Features of the machine are designed to maximize performance, yet make the unit simple to use right out of the box. This unit offers arc improvements on thin and thick materials, with a smooth arc throughout its range. The Millermatic 130 XP also achieves excellent results using inexpensive CO₂ shielding gas.

Millermatic 130 XP Capabilities:

- Wide output range of 30–130 amps
- 4 taps and wire feed tracking offer control similar to infinite voltage control
- Welds materials up to 3/16 in (4.8 mm) thick
- Industrial-quality braking system uses 4 and 8 in (102 and 203 mm) spools, and adapts for 1 lb (0.45 kg) spool
- Wire sizes: solid or stainless steel, .023–.030 in (0.6–0.8 mm); flux-cored, .030–.035 in (0.8–0.9 mm); aluminum, .030–.035 in (0.8–0.9 mm)

Note: Shipped from factory ready to feed .030/.035 in (0.8/0.9 mm) wire.

Comes Complete with:

- Power cord with plug
- 10 ft (3 m) Miller M-10 MIG gun and cable assembly
- 10 ft (3 m) work cable with clamp
- Factory-installed gas solenoid valve
- Extra contact tips
- Sample spool of flux cored wire
- 1 lb spool adapters
- Set-up and operation video tape

Note: Shielding gas and safety equipment not included.

Features

- Superior arc performance
- Exclusive Miller short circuit protection
- Self-aligning drive roll
- Quiet, high-torque drive motor
- Cast aluminum drive housing
- Wire feed speed tracks voltage
- Standard 20 amp circuit used
- Copper transformer windings
- Convenient polarity changeover
- Overload protection
- Built-in contactor
- Durable 10 ft, 100 amp M-10 MIG gun
- Aluminum option available
- Miller's True Blue® Warranty

Benefits

- Improved low-end performance for welding even thinner gauge materials than before — down to 24 gauge. Superior arc with inexpensive CO₂ gas. Improved wetting action on top end.
- "Tip Saver" extends life of contact tips. Easily resets with release of gun trigger. Protects internal components from damage.
- No adjustment required, and easy to replace.
- Low noise, and improved low-end performance.
- Industrial quality, for consistent wire feeding.
- Easy to set and adjust. Covers all voltage ranges.
- Full output on standard household outlet — no special circuit needed.
- Rugged and dependable.
- Easy access to polarity connector makes it fast and easy to change over for solid or flux cored wires.
- Thermal shutdown protects unit if airflow is blocked or the fan circuit fails.
- Makes wire electrically "cold" when not welding, safety feature plus eases use.
- The one-piece handle on gun is molded from a virtually unbreakable, lightweight resin. The rugged unicable outer jacket stands up to the toughest environments, and the trigger switch is rated for 1 million cycles.
- For optimum aluminum welding, combine Miller's exclusive SGA 100 spool gun adapter with the Spoolmate™ 185 spool gun.
- Power source is warranted for 3 years, parts and labor. Original main power rectified parts are warranted for 5 years. Gun warranted for 90 days, parts and labor.

Specifications (Subject to change without notice.)

Light Industrial **CV** **DC** **1** Phase

Rated Output	Amperage Range	Max. Open-Circuit Voltage	Wire Feed Speed Range at No Load	Amps Input at Rated Output, 60 Hz			Dimensions	Net Weight with Gun
				115 V	KVA	KW		
90 A at 18 VDC, 20% Duty Cycle	30–130	28	220–700 IPM (5.5–18 m/min)	20 .59*	2.8 .086*	2.4 .043*	H: 15-1/2 in (394 mm) W: 10 in (254 mm) D: 17 in (432 mm)	69 lb (31 kg)

 Certified by Canadian Standards Association to both Canadian and U.S. Standards.

* While idling.

Ordering Information See back page.



Miller Electric Mfg. Co.
An Illinois Tool Works Company
1635 West Spencer Street
Appleton, WI 54914 USA

International Headquarters
Phone: 920-735-4505
USA FAX: 920-735-4134
Canadian FAX: 920-735-4169
International FAX: 920-735-4125

Web Site
www.MillerWelds.com



Performance Data

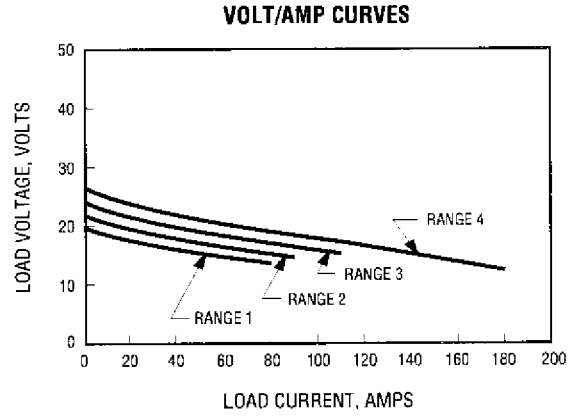
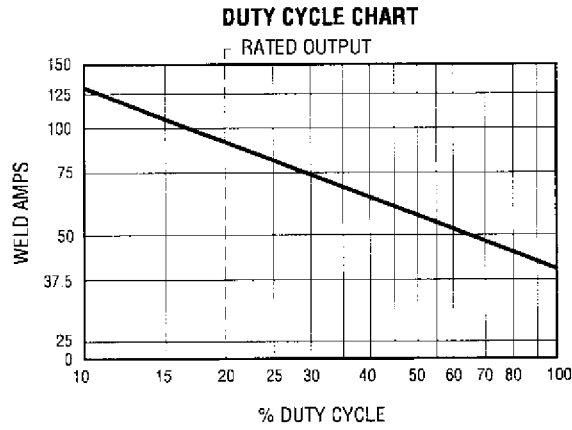

Control Panel

1. Wire Speed Control
2. Voltage Switch
3. Voltage Switch – Fan Only Position
4. Power Switch

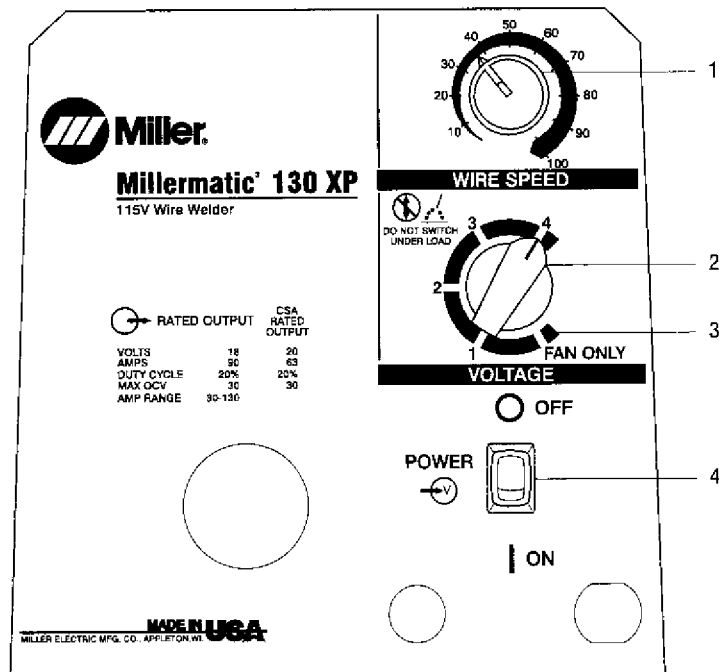

Accessories

M-10 Replacement Gun #195 605

10 ft (3 m). Shipped to run .030/.035 in (0.8/0.9 mm) wire.

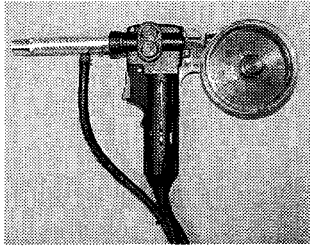

Spoolmate™ 185 #043 701

Includes 20 ft (6 m) cable. When combined with the Millermatic 130 XP and SGA 100, this spool gun welds .030 and .035 in (0.8 and 0.9 mm) wires on 14 gauge to 1/8 in thick aluminum.



Spoolmate™ 185 Curved Barrel Assembly #198 371



Spoolmate™ 185 9 in Straight Barrel Assembly #198 372

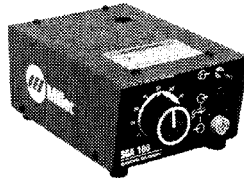

SGA 100 #043 856

Miller's exclusive spool gun adapter is dedicated to the Spoolmate 185 spool gun and is rated at 150 A at 60% duty cycle. Comes with 10 ft (3 m), 115 VAC power cable and plug, 6 ft (1.8 m) interconnecting cable and 5 ft (1.5 m) gas hose.

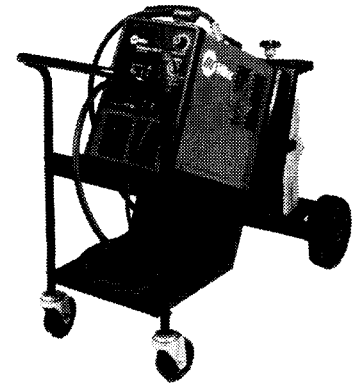

Running Gear/ Cylinder Rack #043 796

Designed for a gas cylinder no larger than 8-1/2 in (216 mm) diameter by 28 in (711 mm) high. (Cylinder not included.)

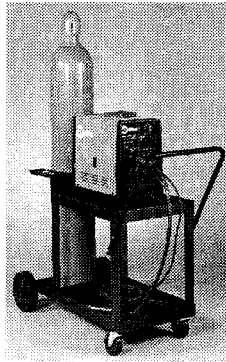

Universal Carrying Cart and Cylinder Rack #042 934

This cart adds convenience to the Millermatic package. The power source mounts securely to the top, and a cylinder rack supports one CO₂/Argon cylinder. The bottom tray

can hold electrode leads or welding hood, gloves, etc. Cylinder rack will accommodate 6-9 in (152-228 mm) diameter, and 24-56 in (610-1422 mm) high cylinders. Net shipping weight is 69 lb (31 kg).

Consumables (Order from Miller Service Parts.)

M-10 Gun Consumables



Contact Tips

- #087 299 .023/.025 in (0.6 mm)
- #000 067 .030 in (0.8 mm)
- #000 068 .035 in (0.9 mm)

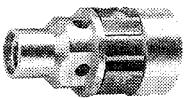

Contact Tip Adapter #169 716



Replacement Liners

- #194 010 .023/.025 in (0.6 mm)
- #194 011 .030/.035 in (0.8/0.9 mm) (standard)



Nozzle #169 715 Standard Flush 1/2 in (13 mm) diameter orifice.

Spot Nozzles

- #176 237 Flat
- #176 239 Inside corner
- #176 241 Outside corner

Gun Convenience Kit #193 973

- Contains:
- 3 - .025 in (0.6 mm) contact tips (#087 299)
 - 5 - .030 in (0.8 mm) contact tips (#000 067)
 - 5 - .035 in (0.9 mm) contact tips (#000 068)
 - 1 - Tip adapter (#169 716)
 - 2 - Shock washers (#169 717)
 - 3 - O-rings (#170 471)
 - 1 - 1/2 in (13mm) diameter orifice nozzle (#169 715)

Drive Rolls (for solid wire) #090 423

For .023/.025, .030 and .035 in (0.6, 0.8 and 0.9 mm) wires.

V-Knurled Drive Rolls #165 603

For .030 and .035 in (0.8 and 0.9 mm) wires.

Spoolmate™ 185 Consumables

Contact Tips

- #186 419 For .030 in (0.8 mm) wire.
- #186 409 For .035 in (0.9 mm) wire.

Nozzle #186 405

Drive Roll (1) #186 413

Push Roll #186 414

For more information on gun consumables, see Lit. Index No. M/10.0.

Ordering Information and System Checklist

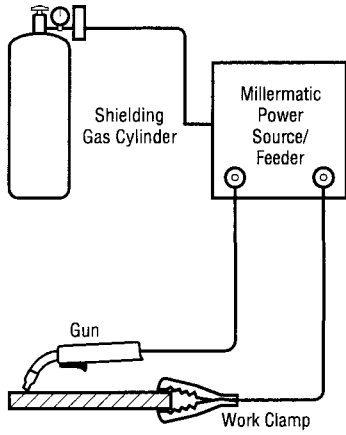

MIG (GMAW) Basic Equipment

Equipment and Options	Stock No.	Description	Qty.	Price
Millermatic 130 XP	#903 556	115 VAC, 60 Hz		
Guns				
M-10 Gun	#195 605	10 ft (3 m). For .030/.035 in (0.8/0.9 mm) wires		
Spoolmate 185	#043 701	Spool gun for aluminum		
Spoolmate 185 Curved Barrel Assembly	#198 371			
Spoolmate 185 9 in Straight Barrel Assembly	#198 372			
SGA 100	#043 856	Spool gun adapter for Spoolmate 185		
Consumables (see page 3)				
Contact Tips				
Contact Tip Adapter				
Replacement Liners				
Nozzles				
Gun Convenience kit	#193 973			
Drive Rolls				
Push Roll	#186 414	For Spoolmate 185		
Accessories				
Universal Carrying Cart and Cylinder Rack	#042 934			
Running Gear/Cylinder Rack	#043 796			
Electrode Wire				
Shielding Gas Cylinder				
Helmet/Gloves/Scratch Brush				
Date:			Total Quoted Price:	



Distributed by:

TRUE BLUE[®]

WARRANTY

Effective January 1, 2000

(Equipment with a serial number preface of "LA" or newer)

This limited warranty supersedes all previous Miller warranties and is exclusive with no other guarantees or warranties expressed or implied.

Warranty Questions?

Call
1-800-4-A-MILLER
for your local
Miller distributor.

Your distributor also gives
you ...

Service

You always get the fast,
reliable response you
need. Most replacement
parts can be in your
hands in 24 hours.

Support

Need fast answers to the
tough welding questions?
Contact your distributor.
The expertise of the
distributor and Miller is
there to help you, every
step of the way.

LIMITED WARRANTY - Subject to the terms and conditions below, Miller Electric Mfg. Co., Appleton, Wisconsin, warrants to its original retail purchaser that new Miller equipment sold after the effective date of this limited warranty is free of defects in material and workmanship at the time it is shipped by Miller. THIS WARRANTY IS EXPRESSLY IN LIEU OF ALL OTHER WARRANTIES, EXPRESS OR IMPLIED, INCLUDING THE WARRANTIES OF MERCHANTABILITY AND FITNESS.

Within the warranty periods listed below, Miller will repair or replace any warranted parts or components that fail due to such defects in material or workmanship. Miller must be notified in writing within thirty (30) days of such defect or failure, at which time Miller will provide instructions on the warranty claim procedures to be followed.

Miller shall honor warranty claims on warranted equipment listed below in the event of such a failure within the warranty time periods. All warranty time periods start on the date that the equipment was delivered to the original retail purchaser, or one year after the equipment is sent to a North American distributor or eighteen months after the equipment is sent to an International distributor.

1. 5 Years Parts - 3 Years Labor
 - * Original main power rectifiers
 - * Inverters (input and output rectifiers only)
2. 3 Years — Parts and Labor
 - * Transformer/Rectifier Power Sources
 - * Plasma Arc Cutting Power Sources
 - * Semi-Automatic and Automatic Wire Feeders
 - * Inverter Power Supplies
 - * Intellitig
 - * Engine Driven Welding Generators
(NOTE: Engines are warranted separately by the engine manufacturer.)
3. 1 Year — Parts and Labor
 - * DS-2 Wire Feeder
 - * Motor Driven Guns (w/exception of Spoolmate 185 & Spoolmate 250)
 - * Process Controllers
 - * Positioners and Controllers
 - * Automatic Motion Devices
 - * RFCS Foot Controls
 - * Induction Heating Power Sources
 - * Water Coolant Systems
 - * HF Units
 - * Grids
 - * Maxstar 140
 - * Spot Welders
 - * Load Banks
 - * Miller Cyclomatic Equipment
 - * Running Gear/Trailers
 - * Plasma Cutting Torches (except APT & SAF Models)
 - * Field Options
(NOTE: Field options are covered under True Blue[®] for the remaining warranty period of the product they are installed in, or for a minimum of one year — whichever is greater.)
4. 6 Months — Batteries
5. 90 Days — Parts
 - * MIG Guns/TIG Torches

- * Induction Heating Coils and Blankets
- * APT, ZIPCUT & PLAZCUT Model Plasma Cutting Torches
- * Remote Controls
- * Accessory Kits
- * Replacement Parts (No labor)
- * Spoolmate 185 & Spoolmate 250

Miller's True Blue[®] Limited Warranty shall not apply to:

1. Consumable components; such as contact tips, cutting nozzles, contactors, brushes, slip rings, relays or parts that fail due to normal wear.
2. Items furnished by Miller, but manufactured by others, such as engines or trade accessories. These items are covered by the manufacturer's warranty, if any.
3. Equipment that has been modified by any party other than Miller, or equipment that has been improperly installed, improperly operated or misused based upon industry standards, or equipment which has not had reasonable and necessary maintenance, or equipment which has been used for operation outside of the specifications for the equipment.

MILLER PRODUCTS ARE INTENDED FOR PURCHASE AND USE BY COMMERCIAL/INDUSTRIAL USERS AND PERSONS TRAINED AND EXPERIENCED IN THE USE AND MAINTENANCE OF WELDING EQUIPMENT.

In the event of a warranty claim covered by this warranty, the exclusive remedies shall be, at Miller's option: (1) repair; or (2) replacement; or, where authorized in writing by Miller in appropriate cases, (3) the reasonable cost of repair or replacement at an authorized Miller service station; or (4) payment of or credit for the purchase price (less reasonable depreciation based upon actual use) upon return of the goods at customer's risk and expense. Miller's option of repair or replacement will be F.O.B., Factory at Appleton, Wisconsin, or F.O.B. at a Miller authorized service facility as determined by Miller. Therefore no compensation or reimbursement for transportation costs of any kind will be allowed.

TO THE EXTENT PERMITTED BY LAW, THE REMEDIES PROVIDED HEREIN ARE THE SOLE AND EXCLUSIVE REMEDIES. IN NO EVENT SHALL MILLER BE LIABLE FOR DIRECT, INDIRECT, SPECIAL, INCIDENTAL OR CONSEQUENTIAL DAMAGES (INCLUDING LOSS OF PROFIT), WHETHER BASED ON CONTRACT, TORT OR ANY OTHER LEGAL THEORY.

ANY EXPRESS WARRANTY NOT PROVIDED HEREIN AND ANY IMPLIED WARRANTY, GUARANTY OR REPRESENTATION AS TO PERFORMANCE, AND ANY REMEDY FOR BREACH OF CONTRACT TORT OR ANY OTHER LEGAL THEORY WHICH, BUT FOR THIS PROVISION, MIGHT ARISE BY IMPLICATION, OPERATION OF LAW, CUSTOM OF TRADE OR COURSE OF DEALING, INCLUDING ANY IMPLIED WARRANTY OF MERCHANTABILITY OR FITNESS FOR PARTICULAR PURPOSE, WITH RESPECT TO ANY AND ALL EQUIPMENT FURNISHED BY MILLER IS EXCLUDED AND DISCLAIMED BY MILLER.

Some states in the U.S.A. do not allow limitations of how long an implied warranty lasts, or the exclusion of incidental, indirect, special or consequential damages, so the above limitation or exclusion may not apply to you. This warranty provides specific legal rights, and other rights may be available, but may vary from state to state.

In Canada, legislation in some provinces provides for certain additional warranties or remedies other than as stated herein, and to the extent that they may not be waived, the limitations and exclusions set out above may not apply. This Limited Warranty provides specific legal rights, and other rights may be available, but may vary from province to province.





Owner's Record

Please complete and retain with your personal records.

Model Name

Serial/Style Number

Purchase Date

(Date which equipment was delivered to original customer.)

Distributor

Address

City

State

Zip



Resources Available

Always provide Model Name and Serial/Style Number.

Contact your Distributor for:

To locate a distributor or service agency near you, call 1-800-4-A-Miller or visit our website at www.MillerWelds.com

Welding Supplies and Consumables

Options and Accessories

Personal Safety Equipment

Service and Repair

Replacement Parts

Training (Schools, Videos, Books)

Technical Manuals (Servicing Information and Parts)

Circuit Diagrams

Welding Process Handbooks

Contact the Delivering Carrier for:

For assistance in filing or settling claims, contact your distributor and/or equipment manufacturer's Transportation Department.

File a claim for loss or damage during shipment.

Miller Electric Mfg. Co.

An Illinois Tool Works Company
1635 West Spencer Street
Appleton, WI 54914 USA

International Headquarters - USA

USA Phone: 920-735-4505 Auto-Attended
USA & Canada FAX: 920-735-4134
International FAX: 920-735-4125

European Headquarters - United Kingdom

Phone: 44 (0) 1204-593493
FAX: 44 (0) 1204-598066

www.MillerWelds.com

