



OM-1311

153 490V

February 2000

Processes



MIG (GMAW) Welding

Flux Cored (FCAW) Welding

Description



Arc Welding Power Source And
Wire Feeder

Millermatic® Vintage And M-25 Gun

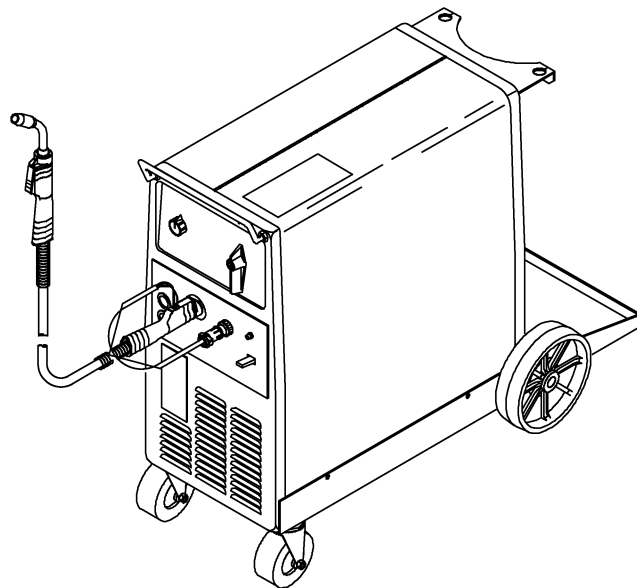

OWNER'S MANUAL

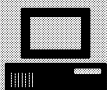

Visit our website at
www.MillerWelds.com

From Miller to You

Thank you and congratulations on choosing Miller. Now you can get the job done and get it done right. We know you don't have time to do it any other way.

That's why when Niels Miller first started building arc welders in 1929, he made sure his products offered long-lasting value and superior quality. Like you, his customers couldn't afford anything less. Miller products had to be more than the best they could be. They had to be the best you could buy.

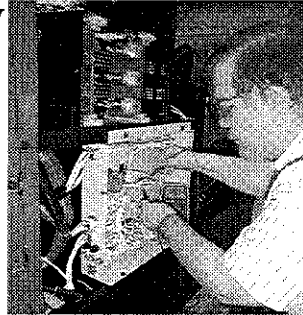

Today, the people that build and sell Miller products continue the tradition. They're just as committed to providing equipment and service that meets the high standards of quality and value established in 1929.

This Owner's Manual is designed to help you get the most out of your Miller products. Please take time to read the Safety precautions. They will help you protect yourself against potential hazards on the worksite. We've

made installation and operation quick and easy. With Miller you can count on years of reliable service with proper maintenance. And if for some reason the unit needs repair, there's a Troubleshooting section that will help you figure out what the problem is. The parts list will then help you to decide which exact part you may need to fix the problem. Warranty and service information for your particular model are also provided.



Miller is the first welding equipment manufacturer in the U.S.A. to be registered to the ISO 9001 Quality System Standard.

Miller Electric manufactures a full line of welders and welding related equipment. For information on other quality Miller products, contact your local Miller distributor to receive the latest full line catalog or individual catalog sheets. To locate your nearest distributor call 1-800-4-A-Miller.

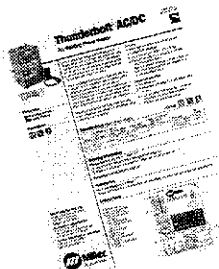

Working as hard as you do – every power source from Miller is backed by the most hassle-free warranty in the business.

Miller offers a Technical Manual which provides more detailed service and parts information for your unit. To obtain a Technical Manual, contact your local distributor. Your distributor can also supply you with Welding Process Manuals such as SMAW, GTAW, GMAW, and GMAW-P.



TABLE OF CONTENTS

WARNING

This product, when used for welding or cutting, produces fumes or gases which contain chemicals known to the State of California to cause birth defects and, in some cases, cancer. (California Health & Safety Code Section 25249.5 et seq.)

The following terms are used interchangeably throughout this manual:
MIG = GMAW

SECTION 1 - SAFETY PRECAUTIONS - READ BEFORE USING	1
1-1. Symbol Usage	1
1-2. Arc Welding Hazards	1
1-3. Additional Symbols for Installation, Operation, and Maintenance	3
1-4. Principal Safety Standards	3
1-5. EMF Information	4
SECTION 1 - CONSIGNES DE SECURITE - LIRE AVANT UTILISATION	5
1-1. Signification des symboles	5
1-2. Dangers relatifs au soudage à l'arc	5
1-3. Dangers supplémentaires en relation avec l'installation, le fonctionnement et la maintenance	7
1-4. Principales normes de sécurité	8
1-5. Information sur les champs électromagnétiques	8
SECTION 2 - INSTALLATION	9
2-1. Specifications	9
2-2. Volt-Ampere Curve	9
2-3. Welding Power Source Duty Cycle And Overheating	10
2-4. Welding Gun Duty Cycle And Overheating	10
2-5. Installing Work Clamp	11
2-6. Installing Gas Supply	11
2-7. Installing Welding Gun	12
2-8. Installing Wire Spool And Adjusting Hub Tension	12
2-9. Setting Gun Polarity	13
2-10. Positioning Jumper Links	13
2-11. Electrical Service Guide	14
2-12. Selecting A Location And Connecting Input Power	14
2-13. Threading Welding Wire	15
SECTION 3 - OPERATION	16
3-1. Front Panel Controls	16
3-2. Center Baffle Controls	16
SECTION 4 - MAINTENANCE & TROUBLESHOOTING	17
4-1. Routine Maintenance	17
4-2. Circuit Breaker CB1	17
4-3. Fuses F1 And F2	18
4-4. Changing Drive Roll And Wire Inlet Guide	18
4-5. Replacing Gun Contact Tip	18
4-6. Cleaning Or Replacing Gun Liner	19
4-7. Replacing Switch And/Or Head Tube	20
4-8. Troubleshooting	21
SECTION 5 - ELECTRICAL DIAGRAM	22
SECTION 6 - PARTS LIST	24
OPTIONS AND ACCESSORIES	
WARRANTY	

SECTION 1 - SAFETY PRECAUTIONS - READ BEFORE USING

som_nd_4/98

1-1. Symbol Usage



Means Warning! Watch Out! There are possible hazards with this procedure! The possible hazards are shown in the adjoining symbols.

▲ Marks a special safety message.

☞ Means "Note"; not safety related.



This group of symbols means Warning! Watch Out! possible ELECTRIC SHOCK, MOVING PARTS, and HOT PARTS hazards. Consult symbols and related instructions below for necessary actions to avoid the hazards.

1-2. Arc Welding Hazards

▲ The symbols shown below are used throughout this manual to call attention to and identify possible hazards. When you see the symbol, watch out, and follow the related instructions to avoid the hazard. The safety information given below is only a summary of the more complete safety information found in the Safety Standards listed in Section 1-4. Read and follow all Safety Standards.

▲ Only qualified persons should install, operate, maintain, and repair this unit.

▲ During operation, keep everybody, especially children, away.



ELECTRIC SHOCK can kill.

Touching live electrical parts can cause fatal shocks or severe burns. The electrode and work circuit is electrically live whenever the output is on. The input power circuit and machine internal circuits are also live when power is on. In semiautomatic or automatic wire welding, the wire, wire reel, drive roll housing, and all metal parts touching the welding wire are electrically live. Incorrectly installed or improperly grounded equipment is a hazard.

- Do not touch live electrical parts.
- Wear dry, hole-free insulating gloves and body protection.
- Insulate yourself from work and ground using dry insulating mats or covers big enough to prevent any physical contact with the work or ground.
- Do not use AC output in damp areas, if movement is confined, or if there is a danger of falling.
- Use AC output ONLY if required for the welding process.
- If AC output is required, use remote output control if present on unit.
- Disconnect input power or stop engine before installing or servicing this equipment. Lockout/tagout input power according to OSHA 29 CFR 1910.147 (see Safety Standards).
- Properly install and ground this equipment according to its Owner's Manual and national, state, and local codes.
- Always verify the supply ground - check and be sure that input power cord ground wire is properly connected to ground terminal in disconnect box or that cord plug is connected to a properly grounded receptacle outlet.
- When making input connections, attach proper grounding conductor first - double-check connections.
- Frequently inspect input power cord for damage or bare wiring - replace cord immediately if damaged - bare wiring can kill.
- Turn off all equipment when not in use.
- Do not use worn, damaged, undersized, or poorly spliced cables.
- Do not drape cables over your body.

- If earth grounding of the workpiece is required, ground it directly with a separate cable.
- Do not touch electrode if you are in contact with the work, ground, or another electrode from a different machine.
- Use only well-maintained equipment. Repair or replace damaged parts at once. Maintain unit according to manual.
- Wear a safety harness if working above floor level.
- Keep all panels and covers securely in place.
- Clamp work cable with good metal-to-metal contact to workpiece or worktable as near the weld as practical.
- Insulate work clamp when not connected to workpiece to prevent contact with any metal object.
- Do not connect more than one electrode or work cable to any single weld output terminal.

SIGNIFICANT DC VOLTAGE exists after removal of input power on inverters.

- Turn Off inverter, disconnect input power, and discharge input capacitors according to instructions in Maintenance Section before touching any parts.



FUMES AND GASES can be hazardous.

Welding produces fumes and gases. Breathing these fumes and gases can be hazardous to your health.

- Keep your head out of the fumes. Do not breathe the fumes.
- If inside, ventilate the area and/or use exhaust at the arc to remove welding fumes and gases.
- If ventilation is poor, use an approved air-supplied respirator.
- Read the Material Safety Data Sheets (MSDSs) and the manufacturer's instructions for metals, consumables, coatings, cleaners, and degreasers.
- Work in a confined space only if it is well ventilated, or while wearing an air-supplied respirator. Always have a trained watch-person nearby. Welding fumes and gases can displace air and lower the oxygen level causing injury or death. Be sure the breathing air is safe.
- Do not weld in locations near degreasing, cleaning, or spraying operations. The heat and rays of the arc can react with vapors to form highly toxic and irritating gases.
- Do not weld on coated metals, such as galvanized, lead, or cadmium plated steel, unless the coating is removed from the weld area, the area is well ventilated, and if necessary, while wearing an air-supplied respirator. The coatings and any metals containing these elements can give off toxic fumes if welded.



ARC RAYS can burn eyes and skin.

Arc rays from the welding process produce intense visible and invisible (ultraviolet and infrared) rays that can burn eyes and skin. Sparks fly off from the weld.

- Wear a welding helmet fitted with a proper shade of filter to protect your face and eyes when welding or watching (see ANSI Z49.1 and Z87.1 listed in Safety Standards).
- Wear approved safety glasses with side shields under your helmet.
- Use protective screens or barriers to protect others from flash and glare; warn others not to watch the arc.
- Wear protective clothing made from durable, flame-resistant material (leather and wool) and foot protection.



WELDING can cause fire or explosion.

Welding on closed containers, such as tanks, drums, or pipes, can cause them to blow up. Sparks can fly off from the welding arc. The flying sparks, hot workpiece, and hot equipment can cause fires and burns. Accidental contact of electrode to metal objects can cause sparks, explosion, overheating, or fire. Check and be sure the area is safe before doing any welding.

- Protect yourself and others from flying sparks and hot metal.
- Do not weld where flying sparks can strike flammable material.
- Remove all flammables within 35 ft (10.7 m) of the welding arc. If this is not possible, tightly cover them with approved covers.
- Be alert that welding sparks and hot materials from welding can easily go through small cracks and openings to adjacent areas.
- Watch for fire, and keep a fire extinguisher nearby.
- Be aware that welding on a ceiling, floor, bulkhead, or partition can cause fire on the hidden side.
- Do not weld on closed containers such as tanks, drums, or pipes, unless they are properly prepared according to AWS F4.1 (see Safety Standards).
- Connect work cable to the work as close to the welding area as practical to prevent welding current from traveling long, possibly unknown paths and causing electric shock and fire hazards.
- Do not use welder to thaw frozen pipes.
- Remove stick electrode from holder or cut off welding wire at contact tip when not in use.
- Wear oil-free protective garments such as leather gloves, heavy shirt, cuffless trousers, high shoes, and a cap.
- Remove any combustibles, such as a butane lighter or matches, from your person before doing any welding.

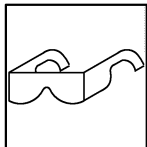

FLYING METAL can injure eyes.

- Welding, chipping, wire brushing, and grinding cause sparks and flying metal. As welds cool, they can throw off slag.
- Wear approved safety glasses with side shields even under your welding helmet.



BUILDUP OF GAS can injure or kill.

- Shut off shielding gas supply when not in use.
- Always ventilate confined spaces or use approved air-supplied respirator.



HOT PARTS can cause severe burns.

- Do not touch hot parts bare handed.
- Allow cooling period before working on gun or torch.

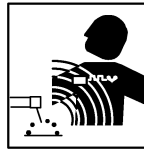

MAGNETIC FIELDS can affect pacemakers.

- Pacemaker wearers keep away.
- Wearers should consult their doctor before going near arc welding, gouging, or spot welding operations.

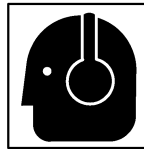

NOISE can damage hearing.

Noise from some processes or equipment can damage hearing.

- Wear approved ear protection if noise level is high.

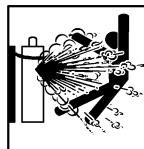

CYLINDERS can explode if damaged.

Shielding gas cylinders contain gas under high pressure. If damaged, a cylinder can explode. Since gas cylinders are normally part of the welding process, be sure to treat them carefully.

- Protect compressed gas cylinders from excessive heat, mechanical shocks, slag, open flames, sparks, and arcs.
- Install cylinders in an upright position by securing to a stationary support or cylinder rack to prevent falling or tipping.
- Keep cylinders away from any welding or other electrical circuits.
- Never drape a welding torch over a gas cylinder.
- Never allow a welding electrode to touch any cylinder.
- Never weld on a pressurized cylinder – explosion will result.
- Use only correct shielding gas cylinders, regulators, hoses, and fittings designed for the specific application; maintain them and associated parts in good condition.
- Turn face away from valve outlet when opening cylinder valve.
- Keep protective cap in place over valve except when cylinder is in use or connected for use.
- Read and follow instructions on compressed gas cylinders, associated equipment, and CGA publication P-1 listed in Safety Standards.

1-3. Additional Symbols For Installation, Operation, And Maintenance



FIRE OR EXPLOSION hazard.

- Do not install or place unit on, over, or near combustible surfaces.
- Do not install unit near flammables.
- Do not overload building wiring – be sure power supply system is properly sized, rated, and protected to handle this unit.



MOVING PARTS can cause injury.

- Keep away from moving parts such as fans.
- Keep all doors, panels, covers, and guards closed and securely in place.



FALLING UNIT can cause injury.

- Use lifting eye to lift unit only, NOT running gear, gas cylinders, or any other accessories.
- Use equipment of adequate capacity to lift and support unit.
- If using lift forks to move unit, be sure forks are long enough to extend beyond opposite side of unit.

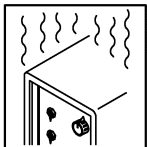

OVERUSE can cause OVERHEATING

- Allow cooling period; follow rated duty cycle.
- Reduce current or reduce duty cycle before starting to weld again.
- Do not block or filter airflow to unit.

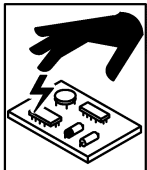

STATIC (ESD) can damage PC boards.

- Put on grounded wrist strap BEFORE handling boards or parts.
- Use proper static-proof bags and boxes to store, move, or ship PC boards.



MOVING PARTS can cause injury.

- Keep away from moving parts.
- Keep away from pinch points such as drive rolls.



WELDING WIRE can cause injury.

- Do not press gun trigger until instructed to do so.
- Do not point gun toward any part of the body, other people, or any metal when threading welding wire.

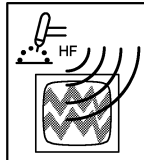

H.F. RADIATION can cause interference.

- High-frequency (H.F.) can interfere with radio navigation, safety services, computers, and communications equipment.
- Have only qualified persons familiar with electronic equipment perform this installation.
- The user is responsible for having a qualified electrician promptly correct any interference problem resulting from the installation.
- If notified by the FCC about interference, stop using the equipment at once.
- Have the installation regularly checked and maintained.
- Keep high-frequency source doors and panels tightly shut, keep spark gaps at correct setting, and use grounding and shielding to minimize the possibility of interference.

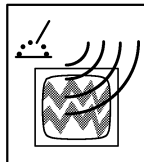

ARC WELDING can cause interference.

- Electromagnetic energy can interfere with sensitive electronic equipment such as computers and computer-driven equipment such as robots.
- Be sure all equipment in the welding area is electromagnetically compatible.
- To reduce possible interference, keep weld cables as short as possible, close together, and down low, such as on the floor.
- Locate welding operation 100 meters from any sensitive electronic equipment.
- Be sure this welding machine is installed and grounded according to this manual.
- If interference still occurs, the user must take extra measures such as moving the welding machine, using shielded cables, using line filters, or shielding the work area.

1-4. Principal Safety Standards

Safety in Welding and Cutting, ANSI Standard Z49.1, from American Welding Society, 550 N.W. LeJeune Rd, Miami FL 33126

Safety and Health Standards, OSHA 29 CFR 1910, from Superintendent of Documents, U.S. Government Printing Office, Washington, D.C. 20402.

Recommended Safe Practices for the Preparation for Welding and Cutting of Containers That Have Held Hazardous Substances, American Welding Society Standard AWS F4.1, from American Welding Society, 550 N.W. LeJeune Rd, Miami, FL 33126

National Electrical Code, NFPA Standard 70, from National Fire Protection Association, Batterymarch Park, Quincy, MA 02269.

Safe Handling of Compressed Gases in Cylinders, CGA Pamphlet P-1, from Compressed Gas Association, 1235 Jefferson Davis Highway, Suite 501, Arlington, VA 22202.

Code for Safety in Welding and Cutting, CSA Standard W117.2, from Canadian Standards Association, Standards Sales, 178 Rexdale Boulevard, Rexdale, Ontario, Canada M9W 1R3.

Safe Practices For Occupation And Educational Eye And Face Protection, ANSI Standard Z87.1, from American National Standards Institute, 1430 Broadway, New York, NY 10018.

Cutting And Welding Processes, NFPA Standard 51B, from National Fire Protection Association, Batterymarch Park, Quincy, MA 02269.

1-5. EMF Information

Considerations About Welding And The Effects Of Low Frequency Electric And Magnetic Fields

Welding current, as it flows through welding cables, will cause electromagnetic fields. There has been and still is some concern about such fields. However, after examining more than 500 studies spanning 17 years of research, a special blue ribbon committee of the National Research Council concluded that: "The body of evidence, in the committee's judgment, has not demonstrated that exposure to power-frequency electric and magnetic fields is a human-health hazard." However, studies are still going forth and evidence continues to be examined. Until the final conclusions of the research are reached, you may wish to minimize your exposure to electromagnetic fields when welding or cutting.

To reduce magnetic fields in the workplace, use the following procedures:

1. Keep cables close together by twisting or taping them.
2. Arrange cables to one side and away from the operator.
3. Do not coil or drape cables around your body.
4. Keep welding power source and cables as far away from operator as practical.
5. Connect work clamp to workpiece as close to the weld as possible.

About Pacemakers:

Pacemaker wearers consult your doctor first. If cleared by your doctor, then following the above procedures is recommended.

SECTION 1 - CONSIGNES DE SECURITE - LIRE AVANT UTILISATION

som_nd_fre 4/98

1-1. Signification des symboles



Signifie Mise en garde ! Soyez vigilant ! Cette procédure présente des risques de danger ! Ceux-ci sont identifiés par des symboles adjacents aux directives.

▲ Identifie un message de sécurité particulier.

Signifie **NOTA** ; n'est pas relatif à la sécurité.



Ce groupe de symboles signifie Mise en garde ! Soyez vigilant ! Il y a des risques de danger reliés aux CHOC ÉLECTRIQUES, aux PIÈCES EN MOUVEMENT et aux PIÈCES CHAUDES. Reportez-vous aux symboles et aux directives ci-dessous afin de connaître les mesures à prendre pour éviter tout danger.

1-2. Dangers relatifs au soudage à l'arc

▲ **Les symboles présentés ci-après sont utilisés tout au long du présent manuel pour attirer votre attention et identifier les risques de danger. Lorsque vous voyez un symbole, soyez vigilant et suivez les directives mentionnées afin d'éviter tout danger. Les consignes de sécurité présentées ci-après ne font que résumer l'information contenue dans les normes de sécurité énumérées à la section 1-4. Veuillez lire et respecter toutes ces normes de sécurité.**

▲ **L'installation, l'utilisation, l'entretien et les réparations ne doivent être confiés qu'à des personnes qualifiées.**

▲ **Au cours de l'utilisation, tenir toute personne à l'écart et plus particulièrement les enfants.**



UN CHOC ÉLECTRIQUE peut tuer.

Un simple contact avec des pièces électriques peut provoquer une électrocution ou des blessures graves. L'électrode et le circuit de soudage sont sous tension dès que l'appareil est sur ON. Le circuit d'entrée et les circuits internes de l'appareil sont également sous tension à ce moment-là. En soudage semi-automatique ou automatique, le fil, le dévidoir, le logement des galets d'entraînement et les pièces métalliques en contact avec le fil de soudage sont sous tension. Des matériels mal installés ou mal mis à la terre présentent un danger.

- Ne jamais toucher les pièces électriques sous tension.
- Porter des gants et des vêtements de protection secs ne comportant pas de trous.
- S'isoler de la pièce et de la terre au moyen de tapis ou d'autres moyens isolants suffisamment grands pour empêcher le contact physique éventuel avec la pièce ou la terre.
- Ne pas se servir de source électrique à courant électrique dans les zones humides, dans les endroits confinés ou là où on risque de tomber.
- Se servir d'une source électrique à courant électrique **UNIQUEMENT** si le procédé de soudage le demande.
- Si l'utilisation d'une source électrique à courant électrique s'avère nécessaire, se servir de la fonction de télécommande si l'appareil en est équipé.
- Couper l'alimentation ou arrêter le moteur avant de procéder à l'installation, à la réparation ou à l'entretien de l'appareil. Déverrouiller l'alimentation selon la norme OSHA 29 CFR 1910.147 (voir normes de sécurité).
- Installer et mettre à la terre correctement cet appareil conformément à son manuel d'utilisation et aux codes nationaux, provinciaux et municipaux.
- Toujours vérifier la terre du cordon d'alimentation - Vérifier et s'assurer que le fil de terre du cordon d'alimentation est bien raccordé à la borne de terre du sectionneur ou que la fiche du cordon est raccordée à une prise correctement mise à la terre.
- En effectuant les raccordements d'entrée fixer d'abord le conducteur de mise à la terre approprié et contre-vérifier les connexions.
- Vérifier fréquemment le cordon d'alimentation pour voir s'il n'est pas endommagé ou dénudé - remplacer le cordon immédiatement s'il est endommagé - un câble dénudé peut provoquer une électrocution.
- Mettre l'appareil hors tension quand on ne l'utilise pas.
- Ne pas utiliser des câbles usés, endommagés, de grosseur insuffisante ou mal épissés.
- Ne pas enrouler les câbles autour du corps.
- Si la pièce soudée doit être mise à la terre, le faire directement avec un câble distinct.
- Ne pas toucher l'électrode quand on est en contact avec la pièce, la terre ou une électrode provenant d'une autre machine.

- N'utiliser qu'un matériel en bon état. Réparer ou remplacer sur-le-champ les pièces endommagées. Entretien l'appareil conformément à ce manuel.
- Porter un harnais de sécurité quand on travaille en hauteur.
- Maintenir solidement en place tous les panneaux et capots.
- Fixer le câble de retour de façon à obtenir un bon contact métal-métal avec la pièce à souder ou la table de travail, le plus près possible de la soudure.
- Isoler la pince de masse quand pas mis à la pièce pour éviter le contact avec tout objet métallique.

Il y a DU COURANT CONTINU IMPORTANT dans les convertisseurs après la suppression de l'alimentation électrique.

- Arrêter les convertisseurs, débrancher le courant électrique, et décharger les condensateurs d'alimentation selon les instructions indiquées dans la partie entretien avant de toucher les pièces.



LES FUMÉES ET LES GAZ peuvent être dangereux.

Le soudage génère des fumées et des gaz. Leur inhalation peut être dangereuse pour votre santé.

- Eloigner votre tête des fumées. Ne pas respirer les fumées.
- A l'intérieur, ventiler la zone et/ou utiliser un échappement au niveau de l'arc pour l'évacuation des fumées et des gaz de soudage.
- Si la ventilation est insuffisante, utiliser un respirateur à alimentation d'air homologué.
- Lire les spécifications de sécurité des matériaux (MSDSs) et les instructions du fabricant concernant les métaux, les consommables, les revêtements, les nettoyants et les dégraissants.
- Travailler dans un espace fermé seulement s'il est bien ventilé ou en portant un respirateur à alimentation d'air. Demander toujours à un surveillant dûment formé de se tenir à proximité. Des fumées et des gaz de soudage peuvent déplacer l'air et abaisser le niveau d'oxygène provoquant des blessures ou des accidents mortels. S'assurer que l'air de respiration ne présente aucun danger.
- Ne pas souder dans des endroits situés à proximité d'opérations de dégraissage, de nettoyage ou de pulvérisation. La chaleur et les rayons de l'arc peuvent réagir en présence de vapeurs et former des gaz hautement toxiques et irritants.
- Ne pas souder des métaux munis d'un revêtement, tels que l'acier galvanisé, plaqué en plomb ou au cadmium à moins que le revêtement n'ait été enlevé dans la zone de soudure, que l'endroit soit bien ventilé, et si nécessaire, en portant un respirateur à alimentation d'air. Les revêtements et tous les métaux renfermant ces éléments peuvent dégager des fumées toxiques en cas de soudage.



LES RAYONS DE L'ARC peuvent provoquer des brûlures dans les yeux et sur la peau.

Le rayonnement de l'arc du procédé de soudage génère des rayons visibles et invisibles intenses (ultraviolets et infrarouges) susceptibles de provoquer

des brûlures dans les yeux et sur la peau. Des étincelles sont projetées pendant le soudage.

- Porter un casque de soudage muni d'un écran de filtre approprié pour protéger votre visage et vos yeux pendant le soudage ou pour regarder (voir ANSI Z49.1 et Z87.1 énuméré dans les normes de sécurité).
- Porter des protections approuvés pour les oreilles si le niveau sonore est trop élevé.
- Utiliser des écrans ou des barrières pour protéger des tiers de l'éclair et de l'éblouissement; demander aux autres personnes de ne pas regarder l'arc.
- Porter des vêtements de protection constitué dans une matière durable, résistant au feu (cuir ou laine) et une protection des pieds.



LE SOUDAGE peut provoquer un incendie ou une explosion.

Le soudage effectué sur des conteneurs fermés tels que des réservoirs, tambours ou des conduites peut provoquer leur éclatement. Des étincelles peuvent être projetées de l'arc de soudure. La projection d'étincelles, des pièces chaudes et des équipements chauds peut provoquer des incendies et des brûlures. Le contact accidentel de l'électrode avec des objets métalliques peut provoquer des étincelles, une explosion, un surchauffement ou un incendie. Avant de commencer le soudage, vérifier et s'assurer que l'endroit ne présente pas de danger.

- Se protéger et d'autres personnes de la projection d'étincelles et de métal chaud.
- Ne pas souder dans un endroit là où des étincelles peuvent tomber sur des substances inflammables.
- Déplacer toutes les substances inflammables à une distance de 10,7 m de l'arc de soudage. En cas d'impossibilité les recouvrir soigneusement avec des protections homologués.
- Des étincelles et des matériaux chauds du soudage peuvent facilement passer dans d'autres zones en traversant de petites fissures et des ouvertures.
- Surveiller tout déclenchement d'incendie et tenir un extincteur à proximité.
- Le soudage effectué sur un plafond, plancher, paroi ou séparation peut déclencher un incendie de l'autre côté.
- Ne pas effectuer le soudage sur des conteneurs fermés tels que des réservoirs, tambours, ou conduites, à moins qu'ils n'aient été préparés correctement conformément à AWS F4.1 (voir les normes de sécurité).
- Brancher le câble sur la pièce le plus près possible de la zone de soudage pour éviter le transport du courant sur une longue distance par des chemins inconnus éventuels en provoquant des risques d'électrocution et d'incendie.
- Ne pas utiliser le poste de soudage pour dégelier des conduites gelées.
- En cas de non utilisation, enlever la bague d'électrode du porte-électrode ou couper le fil à la pointe de contact.
- Porter des vêtements de protection dépourvus d'huile tels que des gants en cuir, une chemise en matériau lourd, des pantalons sans revers, des chaussures hautes et un couvre chef.
- Avant de souder, retirer toute substance combustible de vos poches telles qu'un allumeur au butane ou des allumettes.

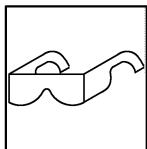

DES PARTICULES VOLANTES peuvent blesser les yeux.

- Le soudage, l'écaillage, le passage de la pièce à la brosse en fil de fer, et le meulage génèrent des étincelles et des particules métalliques volantes. Pendant la période de refroidissement des soudures, elles risquent de projeter du laitier.
 - Porter des lunettes de sécurité avec écrans latéraux ou un écran facial.



LES ACCUMULATIONS DE GAZ risquent de provoquer des blessures ou même la mort.

- Fermer l'alimentation du gaz protecteur en cas de non utilisation.
- Veiller toujours à bien aérer les espaces confinés ou se servir d'un respirateur d'adduction d'air homologué.



DES PIÈCES CHAUDES peuvent provoquer des brûlures graves.

- Ne pas toucher des parties chaudes à mains nues
- Prévoir une période de refroidissement avant d'utiliser le pistolet ou la torche.

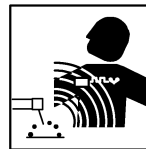

LES CHAMPS MAGNÉTIQUES peuvent affecter les stimulateurs cardiaques.

- Porteurs de stimulateur cardiaque, restez à distance.
- Les porteurs d'un stimulateur cardiaque doivent d'abord consulter leur médecin avant de s'approcher des opérations de soudage à l'arc, de gougeage ou de soudage par points.

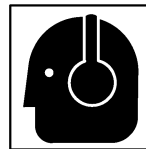

LE BRUIT peut affecter l'ouïe.

Le bruit des processus et des équipements peut affecter l'ouïe.

- Porter des protections approuvés pour les oreilles si le niveau sonore est trop élevé.

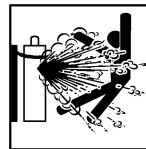

Si des BOUTEILLES sont endommagées, elles pourront exploser.

Des bouteilles de gaz protecteur contiennent du gaz sous haute pression. Si une bouteille est endommagée, elle peut exploser. Du fait que les bouteilles de gaz font normalement partie du procédé de soudage, les

manipuler avec précaution.

- Protéger les bouteilles de gaz comprimé d'une chaleur excessive, des chocs mécaniques, du laitier, des flammes ouvertes, des étincelles et des arcs.
- Placer les bouteilles debout en les fixant dans un support stationnaire ou dans un porte-bouteilles pour les empêcher de tomber ou de se renverser.
- Tenir les bouteilles éloignées des circuits de soudage ou autres circuits électriques.
- Ne jamais placer une torche de soudage sur une bouteille à gaz.
- Une électrode de soudage ne doit jamais entrer en contact avec une bouteille.
- Ne jamais souder une bouteille pressurisée - risque d'explosion.
- Utiliser seulement des bouteilles de gaz protecteur, régulateurs, tuyaux et raccords convenables pour cette application spécifique; les maintenir ainsi que les éléments associés en bon état.
- Ne pas tenir la tête en face de la sortie en ouvrant la soupape de la bouteille.
- Maintenir le chapeau de protection sur la soupape, sauf en cas d'utilisation ou de branchement de la bouteille.
- Lire et suivre les instructions concernant les bouteilles de gaz comprimé, les équipements associés et les publications P-1 CGA énumérées dans les normes de sécurité.

1-3. Dangers supplémentaires en relation avec l'installation, le fonctionnement et la maintenance



Risque D'INCENDIE OU D'EXPLOSION.

- Ne pas installer l'appareil à proximité de produits inflammables
- Ne pas surcharger l'installation électrique - s'assurer que l'alimentation est correctement dimensionnée et protégée avant de mettre l'appareil en service.
- Ne pas placer l'appareil sur, au-dessus ou à proximité de surfaces inflammables.

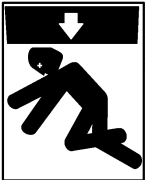

LA CHUTE DE L'APPAREIL peut blesser.

- Utiliser l'anneau de levage uniquement pour soulever l'appareil, NON PAS les chariot, les bouteilles de gaz ou tout autre accessoire.
- Utiliser un engin d'une capacité appropriée pour soulever l'appareil.
- En utilisant des fourches de levage pour déplacer l'unité, s'assurer que les fourches sont suffisamment longues pour dépasser du côté opposé de l'appareil.

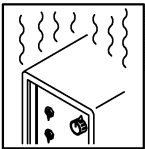

L'EMPLOI EXCESSIF peut SURCHAUFFER L'ÉQUIPEMENT.

- Prévoir une période de refroidissement, respecter le cycle opératoire nominal.
- Réduire le courant ou le cycle opératoire avant de recommencer le soudage.
- Ne pas obstruer les passages d'air du poste.

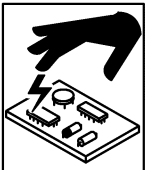

LES CHARGES ÉLECTROSTATIQUES peuvent endommager les circuits imprimés.

- Établir la connexion avec la barrette de terre avant de manipuler des cartes ou des pièces.
- Utiliser des pochettes et des boîtes antistatiques pour stocker, déplacer ou expédier des cartes de circuits imprimés.



DES ORGANES MOBILES peuvent provoquer des blessures.

- Ne pas s'approcher des organes mobiles.
- Ne pas s'approcher des points de coincement tels que des rouleaux de commande.



LES FILS DE SOUDAGE peuvent provoquer des blessures.

- Ne pas appuyer sur la gachette avant d'en avoir reçu l'instruction.
- Ne pas diriger le pistolet vers soi, d'autres personnes ou toute pièce mécanique en engageant le fil de soudage.



DES ORGANES MOBILES peuvent provoquer des blessures.

- Rester à l'écart des organes mobiles comme le ventilateur.
- Maintenir fermés et fixement en place les portes, panneaux, recouvrements et dispositifs de protection.

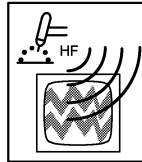

LE RAYONNEMENT HAUTE FRÉQUENCE (H.F.) risque de provoquer des interférences.

- Le rayonnement haute fréquence peut provoquer des interférences avec les équipements de radio-navigation et de communication, les services de sécurité et les ordinateurs.
- Demander seulement à des personnes qualifiées familiarisées avec des équipements électroniques de faire fonctionner l'installation.
- L'utilisateur est tenu de faire corriger rapidement par un électricien qualifié les interférences résultant de l'installation.
- Si le FCC signale des interférences, arrêter immédiatement l'appareil.
- Effectuer régulièrement le contrôle et l'entretien de l'installation.
- Maintenir soigneusement fermés les portes et les panneaux des sources de haute fréquence, maintenir les éclateurs à une distance correcte et utiliser une terre et un blindage pour réduire les interférences éventuelles.

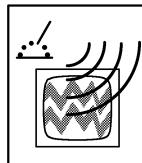

LE SOUDAGE À L'ARC risque de provoquer des interférences.

- L'énergie électromagnétique risque de provoquer des interférences pour l'équipement électronique sensible tel que les ordinateurs et l'équipement commandé par ordinateur tel que les robots.
- Veiller à ce que tout l'équipement de la zone de soudage soit compatible électromagnétiquement.
- Pour réduire la possibilité d'interférence, maintenir les câbles de soudage aussi courts que possible, les grouper, et les poser aussi bas que possible (ex. par terre).
- Veiller à souder à une distance de 100 mètres de tout équipement électronique sensible.
- Veiller à ce que ce poste de soudage soit posé et mis à la terre conformément à ce mode d'emploi.
- En cas d'interférences après avoir pris les mesures précédentes, il incombe à l'utilisateur de prendre des mesures supplémentaires telles que le déplacement du poste, l'utilisation de câbles blindés, l'utilisation de filtres de ligne ou la pose de protecteurs dans la zone de travail.

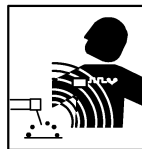

LES CHAMPS MAGNÉTIQUES peuvent affecter les stimulateurs cardiaques.

- Porteurs de stimulateur cardiaque, restez à distance.
- Les porteurs d'un stimulateur cardiaque doivent d'abord consulter leur médecin avant de s'approcher des opérations de soudage à l'arc, de gougeage ou de soudage par points.

1-4. Principales normes de sécurité

Safety in Welding and Cutting, norme ANSI Z49.1, de l'American Welding Society, 550 N.W. Lejeune Rd, Miami FL 33126

Safety and Health Standards, OSHA 29 CFR 1910, du Superintendent of Documents, U.S. Government Printing Office, Washington, D.C. 20402.

Recommended Safe Practice for the Preparation for Welding and Cutting of Containers That Have Held Hazardous Substances, norme AWS F4.1, de l'American Welding Society, 550 N.W. Lejeune Rd, Miami FL 33126

National Electrical Code, NFPA Standard 70, de la National Fire Protection Association, Batterymarch Park, Quincy, MA 02269.

Safe Handling of Compressed Gases in Cylinders, CGA Pamphlet P-1, de la Compressed Gas Association, 1235 Jefferson Davis Highway, Suite 501, Arlington, VA 22202.

Règles de sécurité en soudage, coupage et procédés connexes, norme CSA W117.2, de l'Association canadienne de normalisation, vente de normes, 178 Rexdale Boulevard, Rexdale (Ontario) Canada M9W 1R3.

Safe Practices For Occupation And Educational Eye And Face Protection, norme ANSI Z87.1, de l'American National Standards Institute, 1430 Broadway, New York, NY 10018.

Cutting and Welding Processes, norme NFPA 51B, de la National Fire Protection Association, Batterymarch Park, Quincy, MA 02269.

1-5. Information sur les champs électromagnétiques

Données sur le soudage électrique et sur les effets, pour l'organisme, des champs magnétiques basse fréquence

Le courant de soudage, pendant son passage dans les câbles de soudage, causera des champs électromagnétiques. Il y a eu et il y a encore un certain souci à propos de tels champs. Cependant, après avoir examiné plus de 500 études qui ont été faites pendant une période de recherche de 17 ans, un comité spécial ruban bleu du National Research Council a conclu: "L'accumulation de preuves, suivant le jugement du comité, n'a pas démontré que l'exposition aux champs magnétiques et champs électriques à haute fréquence représente un risque à la santé humaine". Toutefois, des études sont toujours en cours et les preuves continuent à être examinées. En attendant que les conclusions finales de la recherche soient établies, il vous serait souhaitable de réduire votre exposition aux champs électromagnétiques pendant le soudage ou le coupage.

Afin de réduire les champs électromagnétiques dans l'environnement de travail, respecter les consignes suivantes :

- 1 Garder les câbles ensemble en les torsadant ou en les attachant avec du ruban adhésif.
- 2 Mettre tous les câbles du côté opposé de l'opérateur.
- 3 Ne pas courber pas et ne pas entourer pas les câbles autour de votre corps.
- 4 Garder le poste de soudage et les câbles le plus loin possible de vous.
- 5 Relier la pince de masse le plus près possible de la zone de soudure.

Consignes relatives aux stimulateurs cardiaques :

Les personnes qui portent un stimulateur cardiaque doivent avant tout consulter leur docteur. Si vous êtes déclaré apte par votre docteur, il est alors recommandé de respecter les consignes ci-dessus.

SECTION 2 - INSTALLATION

2-1. Specifications

Rated Welding Output	Amperage Range DC	Maximum Open-Circuit Voltage DC	Amperes Input at Rated Load Output, 50 or 60 Hz, Single-Phase				KVA	KW
			200 V	230 V	460 V	575 V		
200 A @ 28 Volts DC, 60% Duty Cycle	40 - 250	42	46	40	20	16	9.5	8.3
250 A @ 28 Volts DC, 40% Duty Cycle			1.1*	1.3*	0.5*	0.4*		

Wire Type And Diameter		Wire Feed Speed Range	Overall Dimensions	Weight
Solid Steel / Stainless Steel	Flux Cored/ Aluminum			
.023 - .045 in (0.6 - 1.2 mm)	.030 - .035 in (0.8 - 0.9 mm) And 3/64 in (1.2 mm) Alu	90 - 1030 IPM (2.9 - 26.2 m/min)	Length: 37 in (940 mm) Width: 19 in (483 mm) Height: 32 in (889 mm)	225 lb (102 kg)
*While idling				
Operating Temperature Range - -20C to +40C			Storage Temperature Range - -30C to + 50C	

2-2. Volt-Ampere Curve

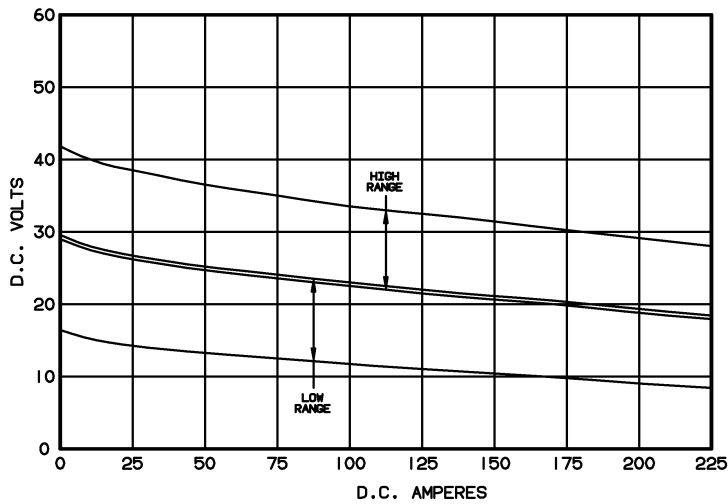

The volt-ampere curves show the minimum and maximum voltage and amperage output capabilities of the welding power source. Curves of other settings fall between the curves shown.

ssb1.1 10/91 - SB-049 424-C

2-3. Welding Power Source Duty Cycle And Overheating

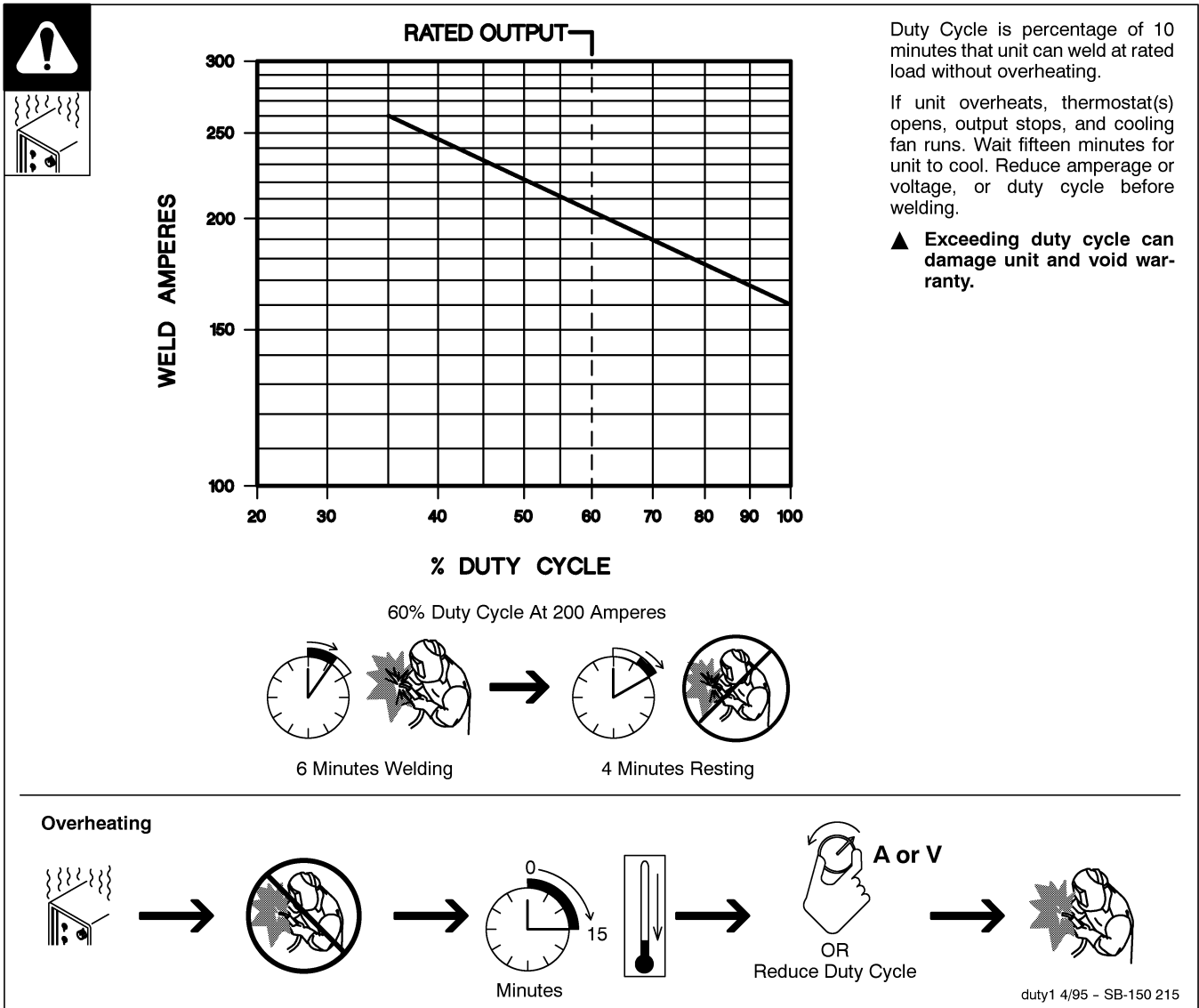

Duty Cycle is percentage of 10 minutes that unit can weld at rated load without overheating.

If unit overheats, thermostat(s) opens, output stops, and cooling fan runs. Wait fifteen minutes for unit to cool. Reduce amperage or voltage, or duty cycle before welding.

▲ Exceeding duty cycle can damage unit and void warranty.

2-4. Welding Gun Duty Cycle And Overheating

CAUTION

WELDING LONGER THAN RATED DUTY CYCLE can damage gun and void warranty.

- Do not weld at rated load longer than shown below.
- Using gasless flux cored wire reduces gun duty cycle.

warn7.1 8/93

Definition	.023 To .045 in (0.6 To 1.1 mm) Hard Or Flux Cored Wires	.023 To .045 in (0.6 To 1.1 mm) Hard Or Flux Cored Wires
<p>10 Minutes</p> <p>Duty Cycle is percentage of 10 minutes that gun can weld at rated load without overheating.</p>	<p>100% Duty Cycle At 200 Amperes Using CO₂</p> <p>100% Duty Cycle At 150 Amperes Using Mixed Gases</p> <p>Continuous Welding</p>	<p>60% Duty Cycle At 300 Amperes Using CO₂</p> <p>60% Duty Cycle At 200 Amperes Using Mixed Gases</p> <p>6 Minutes Welding 4 Minutes Resting</p>

SB1.1 8/93

2-5. Installing Work Clamp



- 1 Work Cable
- 2 Boot

Slide boot onto work cable. Route cable out front panel opening from inside.

- 3 Negative (-) Output Terminal

Connect cable to terminal and cover connection with boot.

- 4 Hardware
- 5 Work Clamp

Route cable through clamp handle and secure as shown.
Close door.

Tools Needed:

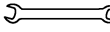
 1/2, 3/4 in

ST-800 918-C

2-6. Installing Gas Supply



- 1 Cylinder Rack
- 2 Chain

Obtain gas cylinder and chain cylinder to rack.

- 3 Gas Hose Fitting
- 4 CO₂ Washer
- 5 Regulator

Install washer and regulator onto cylinder.

- 6 Gas Hose Connection

Obtain gas hose with fittings and install between regulator and welding power source.

- 7 Flow Adjust

Typical flow rate is 20 cfh (cubic feet per hour).

Tools Needed:

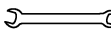
 5/8, 1-1/8 in

ST-154 623-A / Ref. ST-109 492

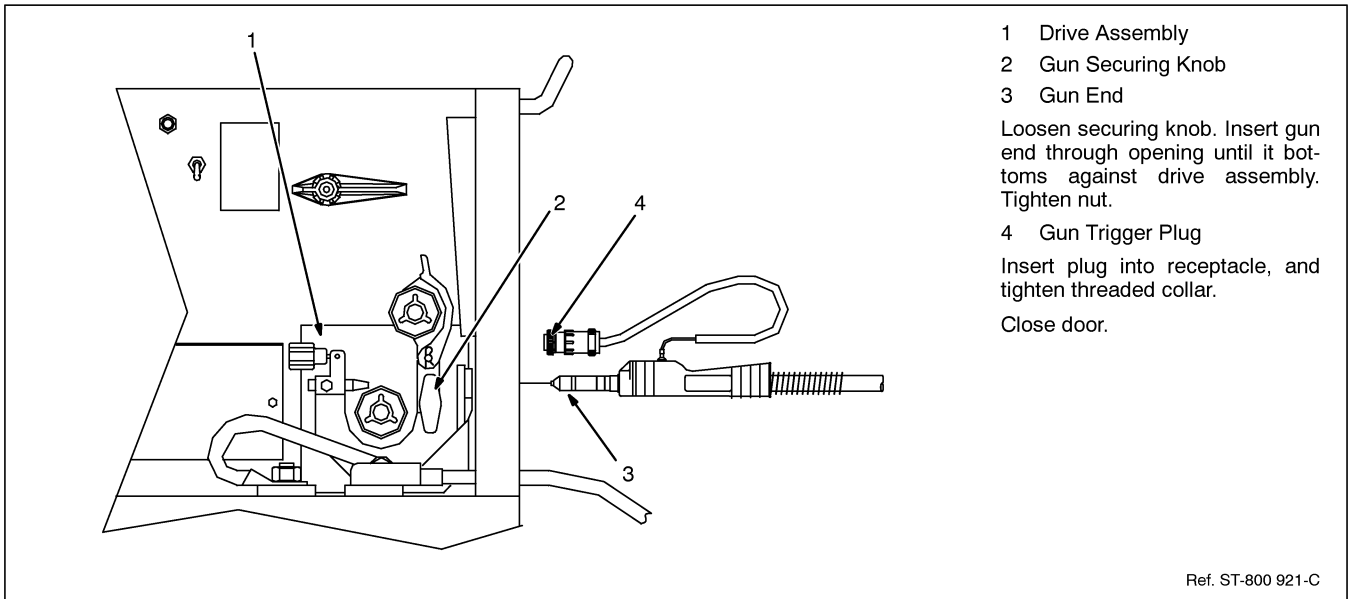

2-7. Installing Welding Gun

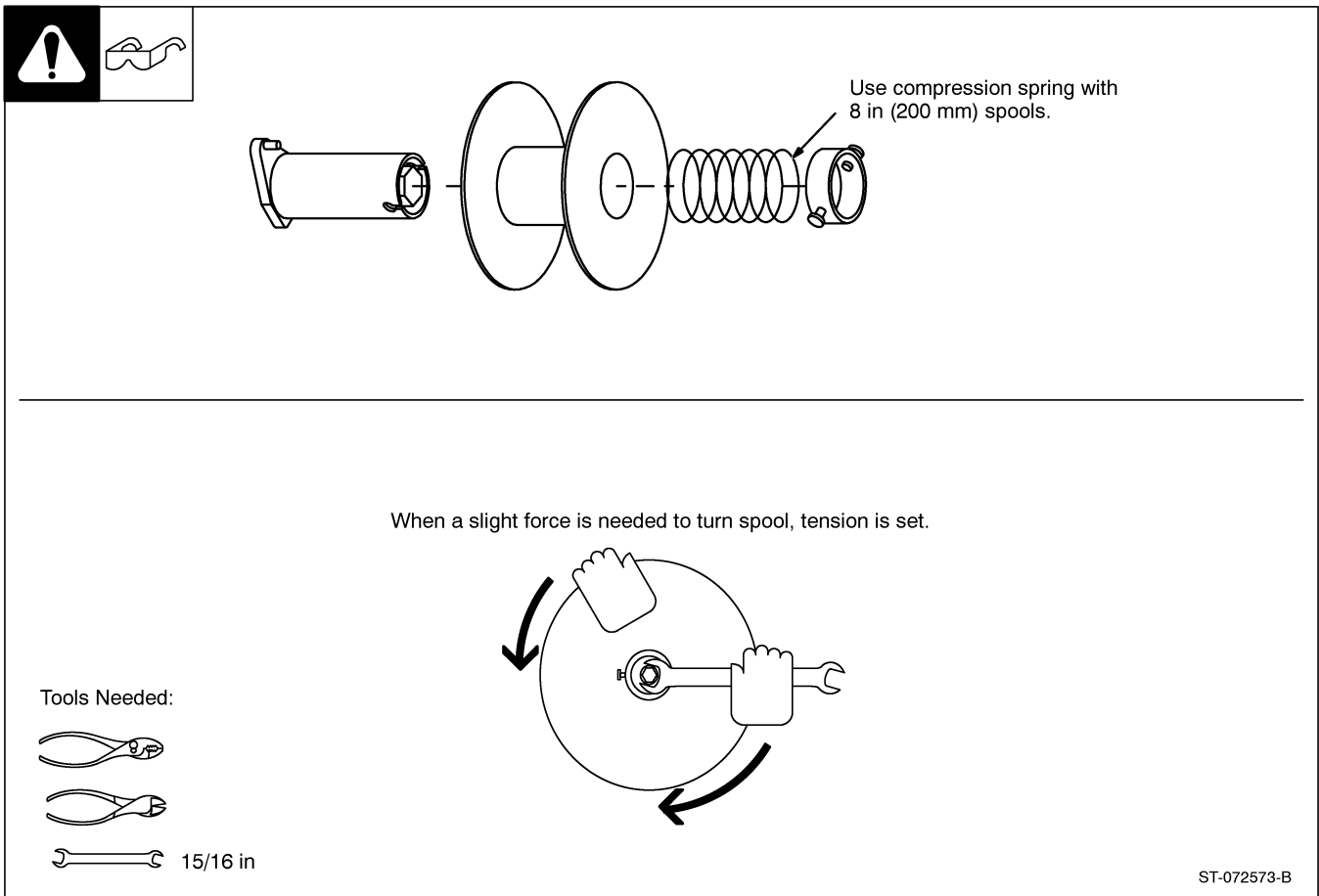

2-8. Installing Wire Spool And Adjusting Hub Tension



2-9. Setting Gun Polarity

1 Polarity Changeover Label
Always read and follow manufacturer's recommended polarity.

Shown As Shipped - Set For Electrode Positive (DCEP) for Solid Steel, Stainless Steel, Aluminum or Flux Core with Gas Wires (GMAW Process).

GUN POLARITY CHANGEOVER CONNECTIONS



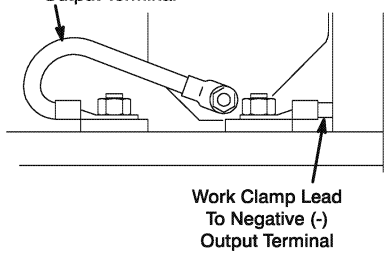

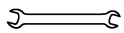
Reverse Lead Connections - Set for Electrode Negative (DCEN). For Gasless Flux Cored Wires (FCAW Process). Drive Assembly Becomes Negative.

Tools Needed:
 3/4, 11/16 in

Ref. 190 821-A

2-10. Positioning Jumper Links





Check input voltage available at site.

- 1 Jumper Links Access Door Open door.
- 2 Jumper Link Label
- 3 Jumper Links Location

Move jumper links to match input voltage, and label on unit.
Close and secure access door.

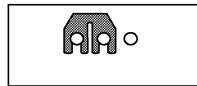
200 VOLTS



230 VOLTS



460 VOLTS



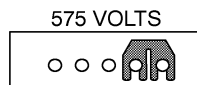

575 VOLTS

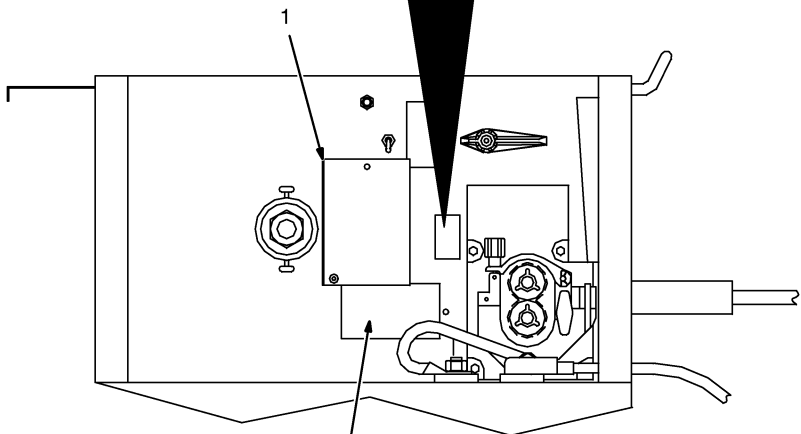

S-153 980 S-156 140

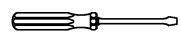

Tools Needed:

 3/8 in

Ref. ST-800 922-C

2-11. Electrical Service Guide

Input Voltage	200	230	460	575
Input Amperes At Rated Output	46	40	20	16
Max Recommended Standard Fuse Or Circuit Breaker Rating In Amperes				
Circuit Breaker ¹ , Time-Delay ²	50	50	25	20
Normal Operating ³	70	60	30	25
Min Input Conductor Size In AWG/Kcmil	10	10	14	14
Max Recommended Input Conductor Length In Feet (Meters)	59 (18)	77 (24)	122 (37)	190 (58)
Min Grounding Conductor Size In AWG/Kcmil	10	10	14	14

Reference: 1999 National Electrical Code (NEC)

1 Choose a circuit breaker with time-current curves comparable to a Time Delay Fuse.

2 "Time-Delay" fuses are UL class "RK5".

3 "Normal Operating" (general purpose - no intentional delay) fuses are UL class "K5" (up to and including 60 amp), and UL class "H" (65 amp and above).

▲ **Caution:** Failure to follow these fuse and circuit breaker recommendations could create an electric shock or fire hazard.

2-12. Selecting A Location And Connecting Input Power



18 in (457 mm) of
space for airflow

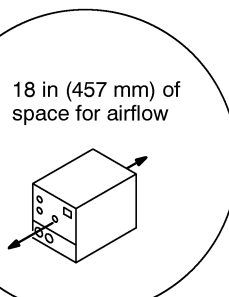



▲ Do not move or operate unit where it could tip.

▲ Always connect grounding conductor first.

⊕ = GND/PE

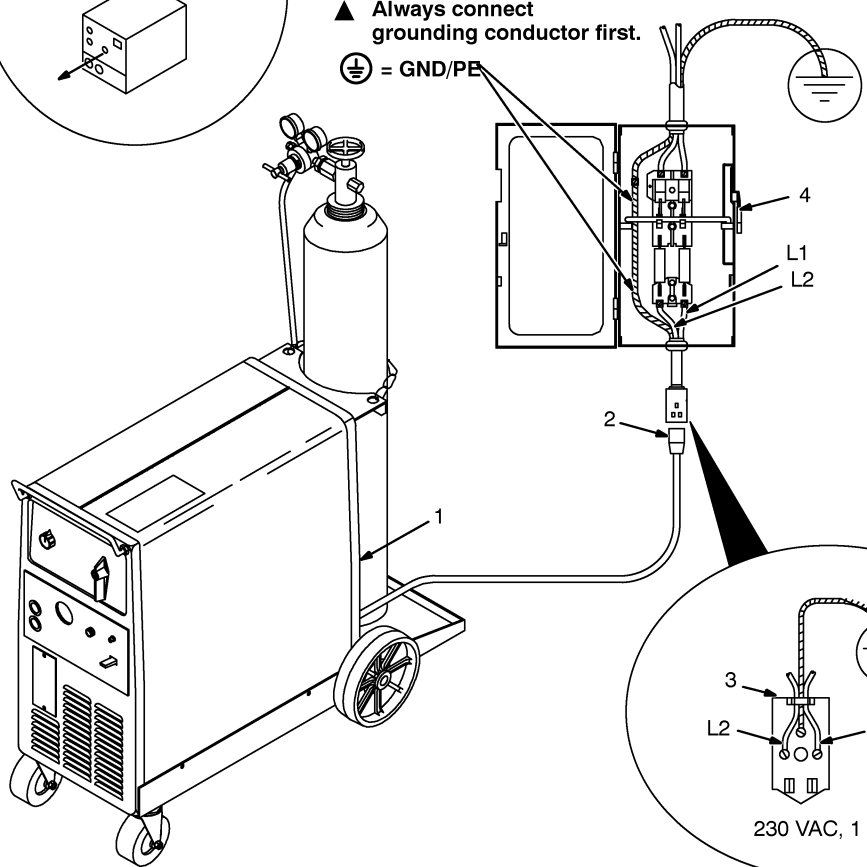

- 1 Rating Label
Supply correct input power.
- 2 Plug
- 3 Receptacle
Connect plug to receptacle.
- 4 Line Disconnect Device
See Section 2-11.

▲ **Special installation may be required where gasoline or volatile liquids are present - see NEC Article 511 or CEC Section 20.**

230 VAC, 1 ~

ST-800 923-A

2-13. Threading Welding Wire



- 1 Wire Spool
 - 2 Welding Wire
 - 3 Inlet Wire Guide
 - 4 Pressure Adjustment Knob
 - 5 Drive Roll
 - 6 Outlet Wire Guide
 - 7 Gun Conduit Cable
- Lay gun cable out straight.

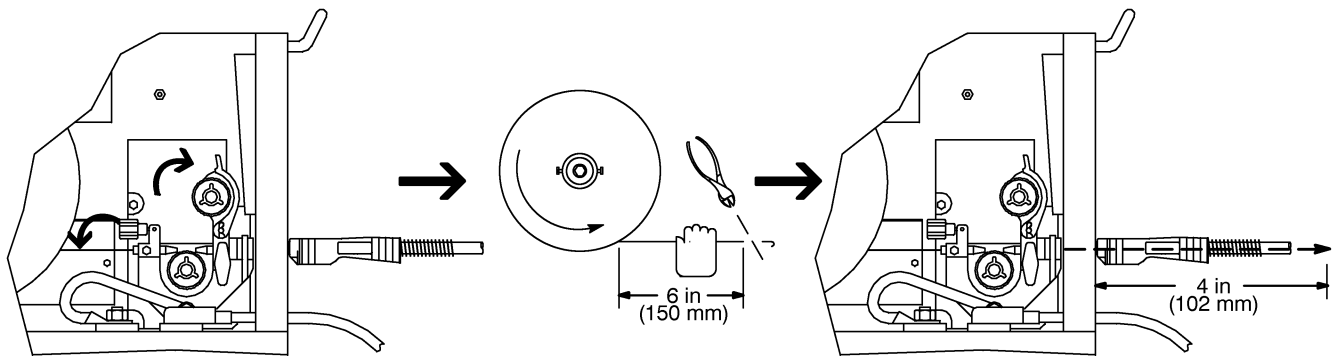
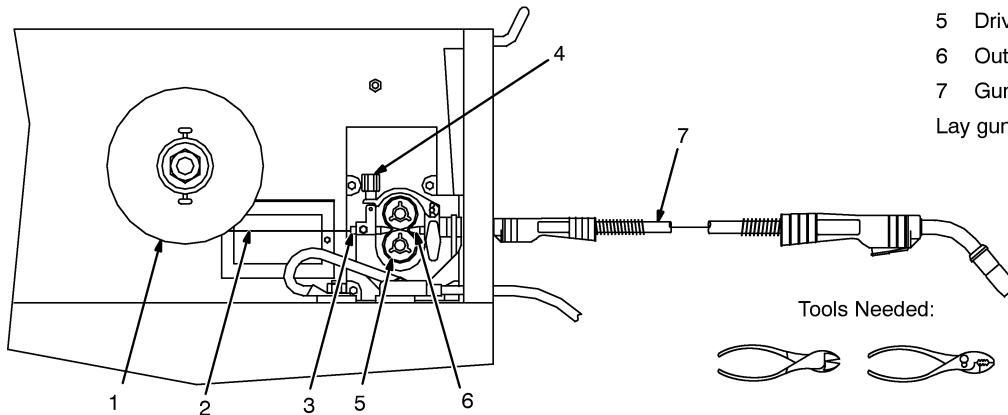

Open pressure assembly.

Pull and hold wire; cut off end.

Push wire thru guides into gun; continue to hold wire.

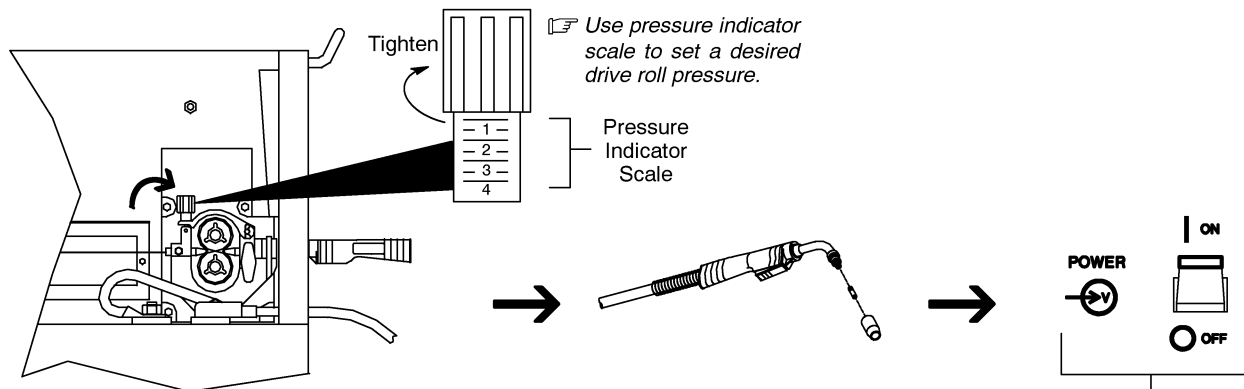

Close and tighten pressure assembly, and let go of wire.

Remove gun nozzle and contact tip.

Turn On.

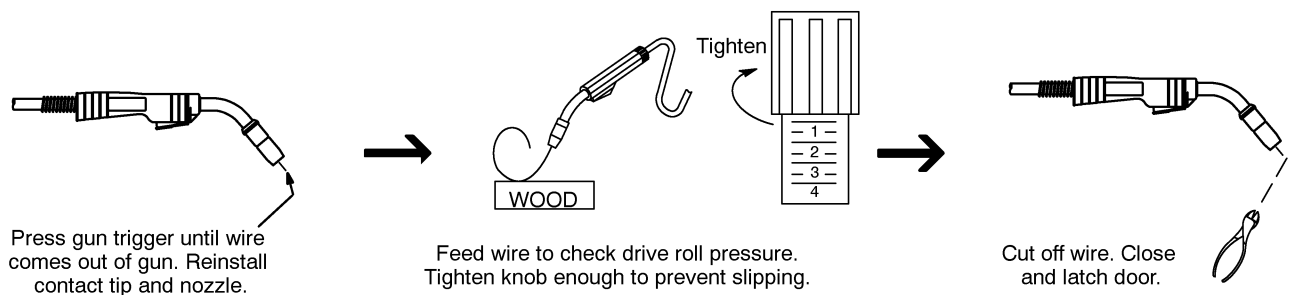

Press gun trigger until wire comes out of gun. Reinstall contact tip and nozzle.

Feed wire to check drive roll pressure. Tighten knob enough to prevent slipping.

Cut off wire. Close and latch door.

SECTION 3 - OPERATION

3-1. Front Panel Controls



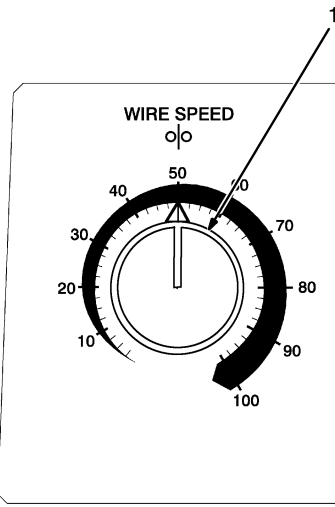

WIRE SPEED
10 20 30 40 50 60 70 80 90 100

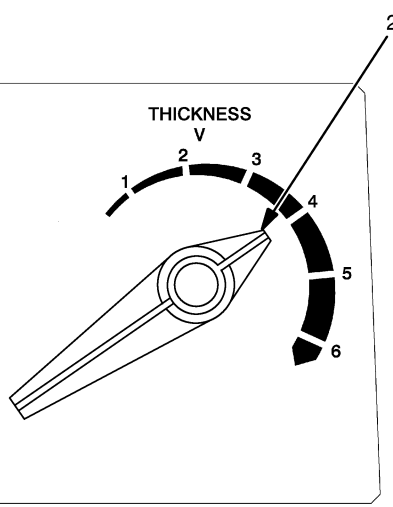

THICKNESS
V
1 2 3 4 5 6

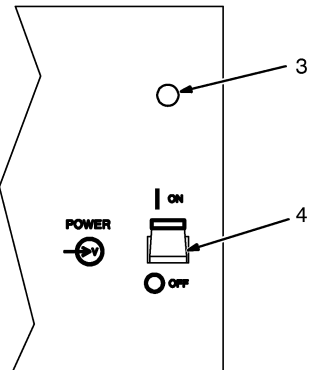

3
POWER ON OFF
4

Controls For Standard Units

- 1 Wire Speed Control

The scale around the control is percent, not wire feed speed.

- 2 Voltage Switch

Use control and Voltage Range Selector (see Section 3-2) to set arc voltage. Step 6 of Low range and Step 1 of High range overlap.

- 3 Pilot Light
- 4 Power Switch

Ref. ST-171 639-C / Ref. ST-174 843-A

3-2. Center Baffle Controls

PRESS TO RESET
CB1

DO NOT SWITCH UNDER LOAD

WIRE MODE	VOLTAGE RANGE
■ FULL	■ HIGH
■ LOW	■ LOW

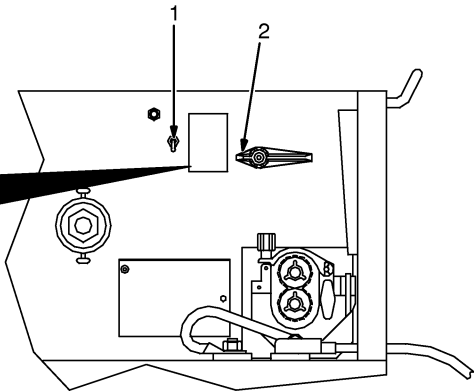

1
2

- 1 Wire Mode Switch

For better control of wire speed use the Low position when wire speed is between 90 and 670 ipm. Use the Full position when wire speed is between 150 ipm and 1030 ipm.

- 2 Voltage Range Selector

Place switch in desired position.

Ref. ST-800 919-B / S-171 601

SECTION 4 - MAINTENANCE & TROUBLESHOOTING

4-1. Routine Maintenance

		Disconnect power before maintaining.		<i>Maintain more often during severe conditions.</i>	
3 Months					
		Replace Damaged Or Unreadable Labels		Clean And Tighten Weld Terminals	
Repair Or Replace Cracked Cables And Cords		Clean And Tighten Weld Terminals			
6 Months					
Blow Out Or Vacuum Inside		Remove drive roll and carrier. Apply light coat of oil or grease to drive motor shaft.			

4-2. Circuit Breaker CB1

		<ol style="list-style-type: none"> 1 Circuit Breaker CB1 If CB1 opens, wire feeding stops. 2 Welding Gun Check gun liner for blockage or kinks. 3 Wire Drive Assembly Check for jammed wire, binding drive gear or misaligned drive rolls. Allow cooling period and reset breaker. Close door. 	

Ref. ST-800 924-C

4-3. Fuses F1 And F2

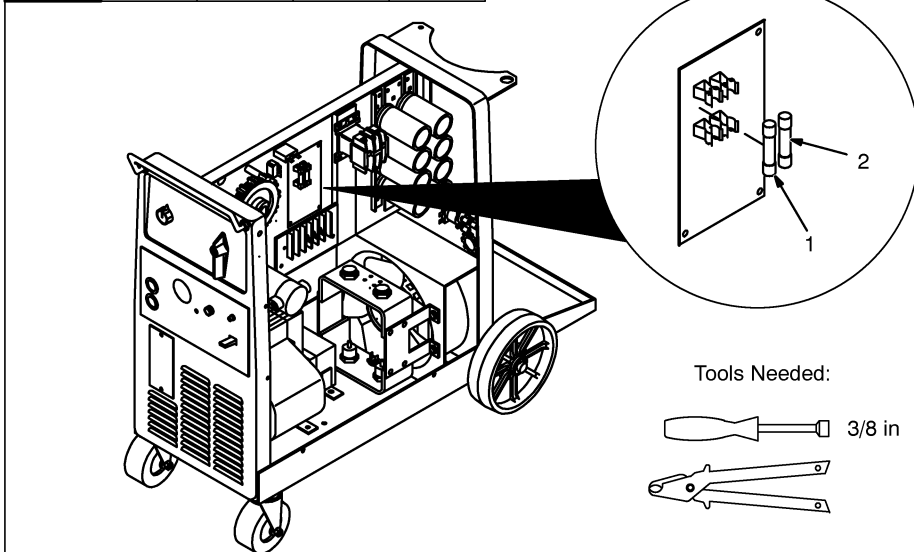
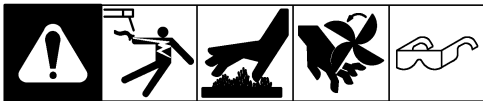

▲ Turn Off unit, and disconnect input power.

1 Fuse F1 (See Parts List For Rating)

F1 protects the 115 volts ac winding of transformer T1. If F1 opens, all weld output stops and pilot light PL1 goes out.

2 Fuse F2 (See Parts List For Rating)

F2 protects the 24 volts ac winding of transformer T1. If F2 opens, all weld output stops.

Tools Needed:

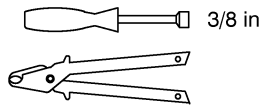

Ref. ST-800 928-B

4-4. Changing Drive Roll And Wire Inlet Guide

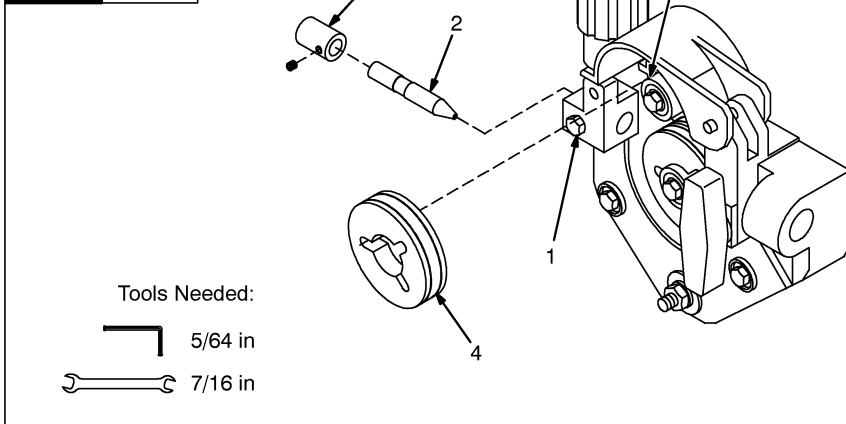

Tools Needed:

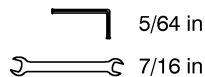

1 Securing Screw

2 Inlet Wire Guide

Loosen screw. Slide tip as close to drive rolls as possible without touching. Tighten screw.

3 Anti-Wear Guide

Install guide as shown.

4 Drive Roll

Install correct drive roll for wire size and type.

5 Drive Roll Securing Nut

Turn nut one click to secure drive roll.

ST-150 227-D

4-5. Replacing Gun Contact Tip

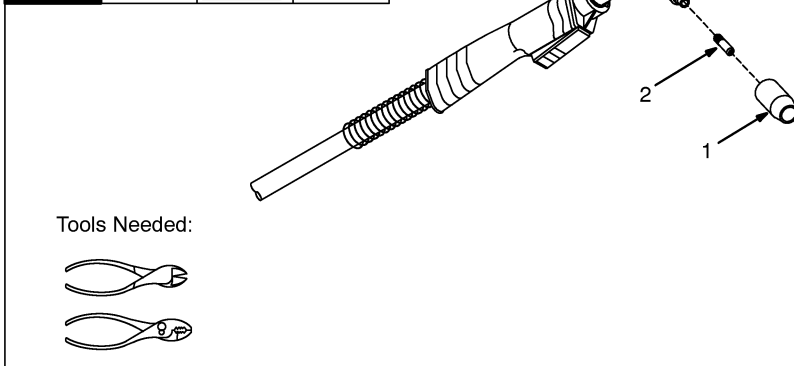

▲ Turn Off unit before replacing contact tip.

1 Nozzle

2 Contact Tip

Cut off welding wire at contact tip. Remove nozzle.

Remove contact tip and install new contact tip. Reinstall nozzle.

Tools Needed:

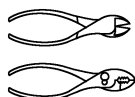

Ref. 800 797-C

4-6. Cleaning Or Replacing Gun Liner

▲ Disconnect gun first.

Tools Needed:

3/8 in

Head tube

Remove nozzle, contact tip, adapter, and wire outlet guide.

3/8 in

Lay gun cable out straight before installing new liner.

Remove liner.

Blow out gun casing.

To Reassemble Gun:
Insert new liner.
Install and tighten wire outlet guide.
Cut liner off 3/4 in (20 mm) (3/8 in [9.5 mm] for aluminum) from head tube.
Install adapter, contact tip, and nozzle.

Ref. ST-800 797-C

4-7. Replacing Switch And/Or Head Tube

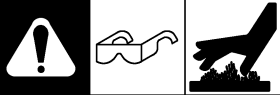

▲ Disconnect gun first.

1 Remove handle locking nut.

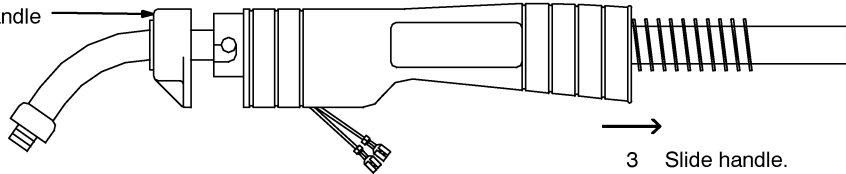

3 Slide handle.

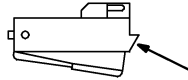

2 Remove switch housing. Note: If installing new switch, push switch lead connectors onto terminal of new switch (polarity is not important). Install switch back into handle, and secure with handle locking nut. If replacing head tube, continue to end of figure.

4 Secure head tube in vice.

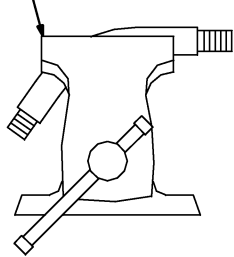

5 Loosen jam nut. Remove from vice and turn head tube out by hand.

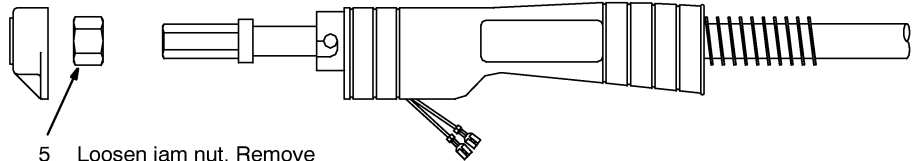

6 Install existing shock washer onto new head tube. Hand-tighten head tube into connector cable.

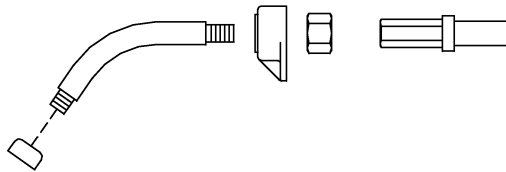

7 Place head tube in vice and tighten until nuts are tight.

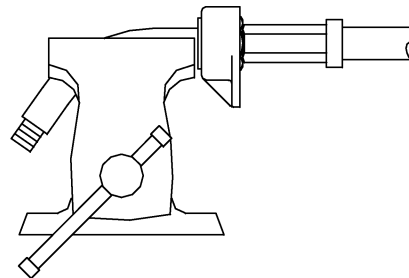

8 Remove from vice. Reposition handle and install switch housing. Secure with handle locking nut.

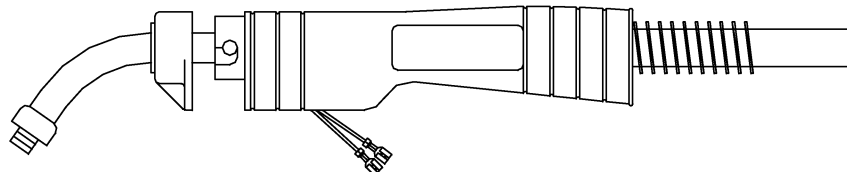

Tools Needed:

 3/4 in



Ref. ST-800 795-C

4-8. Troubleshooting

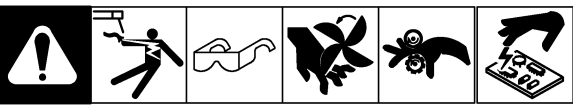
	
Welding Trouble	Remedy
No weld output; wire does not feed.	Secure power cord plug in receptacle (see Section 2-12).
	Reset circuit breaker CB1 (see Section 4-2).
	Replace fuse F1 and/or F2 (see Section 4-3).
	Replace building line fuse or reset circuit breaker if open (see Section 2-12).
	Secure gun trigger plug in receptacle or repair leads, or replace trigger switch (see Section 2-7 and/or NO TAG).
	Thermostat TP1 open (overheating). Allow fan to run; the thermostat will close when the unit has cooled (see Section 2-3).
No weld output; wire feeds.	Connect work clamp to get good metal to metal contact.
	Replace contact tip (see Section 4-5).
Low weld output.	Connect unit to proper input voltage or check for low line voltage (see Section 2-12).
Wire Drive/Gun Trouble	Remedy
Electrode wire feeding stops during welding.	Straighten gun cable and/or replace damaged parts (see Section 4-6).
	Adjust drive roll pressure (see Section 2-13).
	Readjust hub tension (see Section 2-8).
	Replace contact tip if blocked (see Section 4-5).
	Clean or replace wire inlet guide or liner if dirty or plugged (see Section 4-6).
	Replace drive rolls if worn or slipping (see Section 4-4).
	Secure gun trigger plug in receptacle or repair leads, or replace trigger switch (see Section 2-7 and/or NO TAG).
	Check and replace F1 and/or F2 (see Section 4-3).
	Check and clear any restrictions at drive assembly and liner (see Section 4-6).
	Have nearest Factory Authorized Service Agent check drive motor.
Check relay CR1, and replace if necessary.	

SECTION 5 - ELECTRICAL DIAGRAM

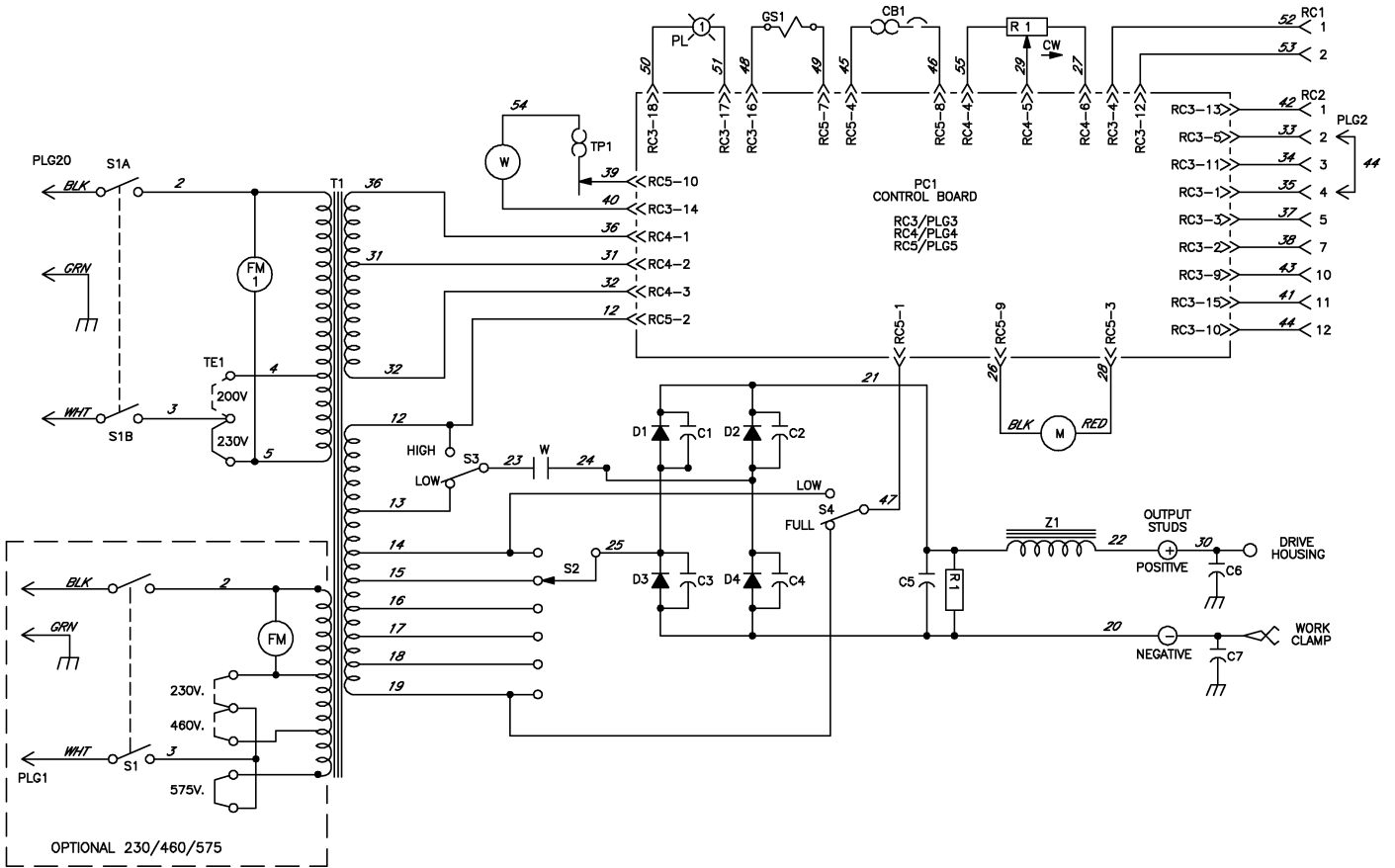

SB-173 544-E

Figure 5-1. Circuit Diagram For Welding Power Source

SECTION 6 - PARTS LIST

☞ Hardware is common and not available unless listed.

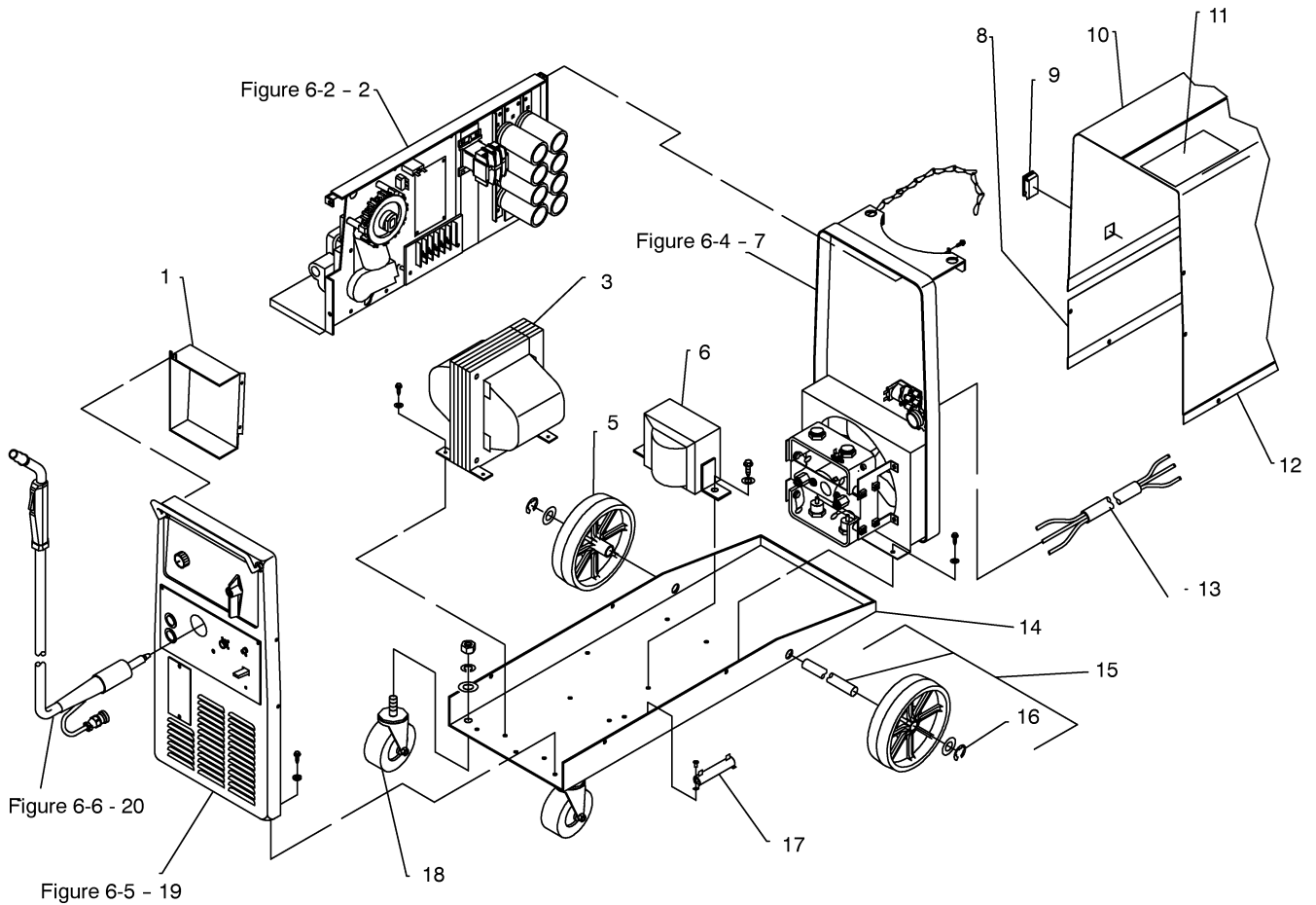

ST-800 930-D

Figure 6-1. Main Assembly

Item No.	Dia. Mkgs.	Part No.	Description	Quantity
----------	------------	----------	-------------	----------

Figure 6-1. Main Assembly

...	1	146 168	PANEL, center enclosure	1
...	PLG7	083 526	HOUSING RECEPTACLE & SOCKETS, (consisting of)	1
...		009 418	TERMINAL, female 1skt 20-14 wire	12
...	2	Figure 6-2	BAFFLE, center w/components	1
...	3	T1	TRANSFORMER, pwr main (200/230)	1
...	3	T1	TRANSFORMER, pwr main (230/460/575)	1
...	5	186 758	WHEEL, polypropylene 10 in dia x 2.250 wide x .750 bore	2
...	6	Z1	STABILIZER	1
...	7	Figure 6-4	PANEL, rear w/components	1

Item No.	Dia. Mkgs.	Part No.	Description	Quantity
Figure 6-1. Main Assembly				
... 8		146 165	.. PANEL, side LH	1
... 9		089 899	.. LATCH, slide flush mtg hole	2
... 10		146 167	.. PANEL, side	1
... 11		134 464	.. LABEL, warning general precautionary	1
... 12		+170 513	.. WRAPPER	1
...		117 860	.. BLANK, snap-in nyl .187mtg hole	2
... 13		188 911	.. CORD SET, pwr 250V 8-10ga 3/c 12ft	1
... 13		187 255	.. CORD SET, pwr 250V 8-10ga 3/c 12ft (230/460/575)	1
... 14		146 161	.. BASE	1
... 15		052 692	.. AXLE, running gear (consisting of)	1
... 16		121 614	.. RING, retaining ext .750 shaft x .085grv depth	2
... 17	R1	091 685	.. RESISTOR, WW fxd 50W 25 ohm	1
... 18		008 999	.. CASTER, plstc swvl 4 in dia	2
... 19		Figure 6-5	.. PANEL, front w/components	1
... 20		169 596	.. GUN, 12 ft .030-.035 wire (Fig 6-4)	1
...		192 121	.. REGULATOR/FLOWMETER, 10-50 CFH	1
...		144 108	.. HOSE, gas 5ft	1
...		130 750	.. CLAMP, ground 350A	1
...		600 318	.. CABLE, weld cop strd No. 3 (order by ft)	10ft

+When ordering a component originally displaying a precautionary label, the label should also be ordered.

To maintain the factory original performance of your equipment, use only Manufacturer's Suggested Replacement Parts. Model and serial number required when ordering parts from your local distributor.

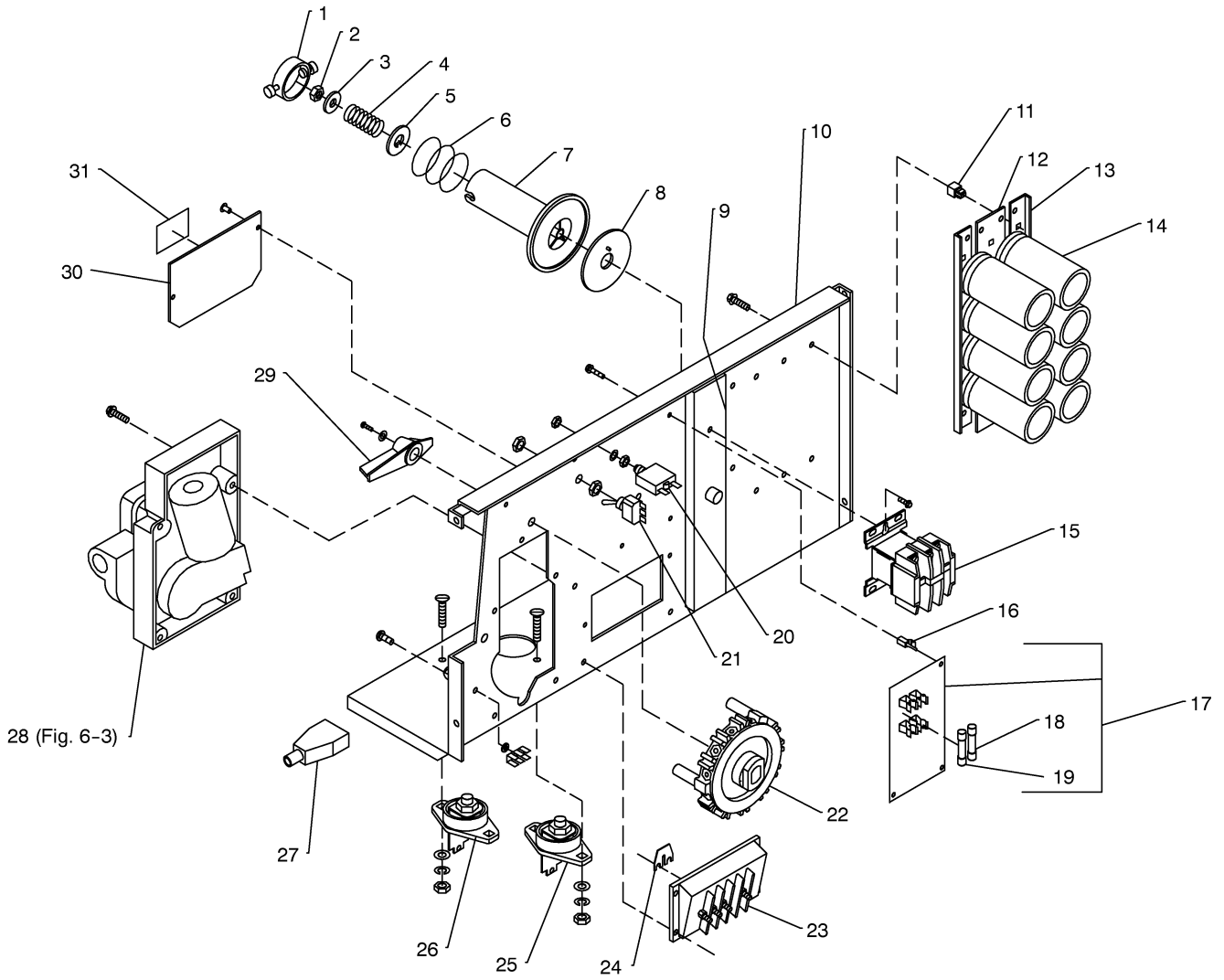

28 (Fig. 6-3)

☐ Hardware is common and not available unless listed.

ST-800 931-D

Figure 6-2. Baffle, Center w/Components

Item No.	Dia. Mkgs.	Part No.	Description	Quantity
----------	------------	----------	-------------	----------

Figure 6-2. Baffle, Center w/Components (Fig 6-1 Item 2)

.. 1		058 427	.. RING, retaining spool	1
.. 2		085 980	.. NUT, stl hex full .625-11	1
.. 3		605 941	.. WASHER, flat stl .640 ID x 1.000 OD x 14ga thk	1
.. 4		186 437	.. SPRING, cprsn .845 OD x .110 wire x 1.500	1
.. 5		057 971	.. WASHER, flat stl keyed 1.500dia x .125thk	1
.. 6		057 745	.. SPRING, cprsn 2.430 OD x .090 wire x 2.500	1
.. 7		186 435	.. HUB, spool	1
.. 8		186 436	.. WASHER, brake plastic	2
.. 9		177 307	.. REEL, support	1
.. 10		174 812	.. BAFFLE, center	1
..		186 998	.. KIT, capacitor bank (consisting of)	1
.. 11		083 147	.. GROMMET, scr No. 8/10 panel hole .312sq .500 high	6
.. 12		082 902	.. STRIP, mtg center capacitor	1
.. 13		185 643	.. STRIP, mtg capacitor	2
.. 14	C5	184 584	.. CAPACITOR, elctlt 15000uf 45VDC	8
..		185 642	.. INSULATOR, capacitor	2
.. 15	W	195 568	.. CONTACTOR w/LINKS, def prp 60A 3P (consisting of)	1
..		114 786	.. LINK, connecting contactor terminal	2
.. 16		134 201	.. STAND-OFF SUPPORT, PC card .312/.375 w/post & lock	4
.. 17	PC1	173 002	.. CIRCUIT CARD, motor speed control (consisting of)	1
..	CR1	*080 388	.. RELAY, encl 24 VAC 3PDT	1
.. 18	F2	*012 658	.. FUSE, mintr gl slo-blo 2A 125V	1
.. 19	F1	*073 426	.. FUSE, mintr gl slo-blo 5A 125V	1
..	PLG3	165 896	.. CONNECTOR & SOCKETS	1
..	PLG4	135 558	.. CONNECTOR & SOCKETS	1
..	PLG5	165 745	.. CONNECTOR & SOCKETS	1
.. 20	CB1	083 431	.. CIRCUIT BREAKER, man reset 1P 5A 250VAC	1
.. 21	S3	011 609	.. SWITCH, tgl SPDT 15A 125VAC	1
.. 22	S4	171 610	.. SWITCH, selector 2 position (When ordering this part order 186 058 also)	1
..		186 058	.. COVER, dust range switch	1
.. 23	TE1	189 910	.. TERMINAL ASSEMBLY, pri 1ph 2V (200/230) (consisting of)	1
.. 23	TE1	195 551	.. TERMINAL ASSEMBLY, pri 1ph 3V (230/460/575) (consisting of)	1
.. 24		038 618	.. LINK, jumper term bd pri	As Rq'd
.. 25	POS	039 047	.. TERMINAL, pwr output red (consisting of)	1
.. 26	NEG	039 046	.. TERMINAL, pwr output black (consisting of)	1
..	C6,7	128 750	.. CAPACITOR, cer disc .1uf 500VDC	2
.. 27		071 971	.. COVER, cable	1
.. 28		Fig 6-3	.. WIRE DRIVE & GEARS	1
.. 29		148 956	.. HANDLE, switch	1
.. 30		+188 917	.. DOOR, access chgov	1
.. 31		021 469	.. LABEL, danger high voltage	1

+When ordering a component originally displaying a precautionary label, the label should also be ordered.

*Recommended Spare Parts.

To maintain the factory original performance of your equipment, use only Manufacturer's Suggested Replacement Parts. Model and serial number required when ordering parts from your local distributor.

**See Table 6-1
Drive Roll & Wire Guide Kits.**

☞ Hardware is common and not available unless listed.

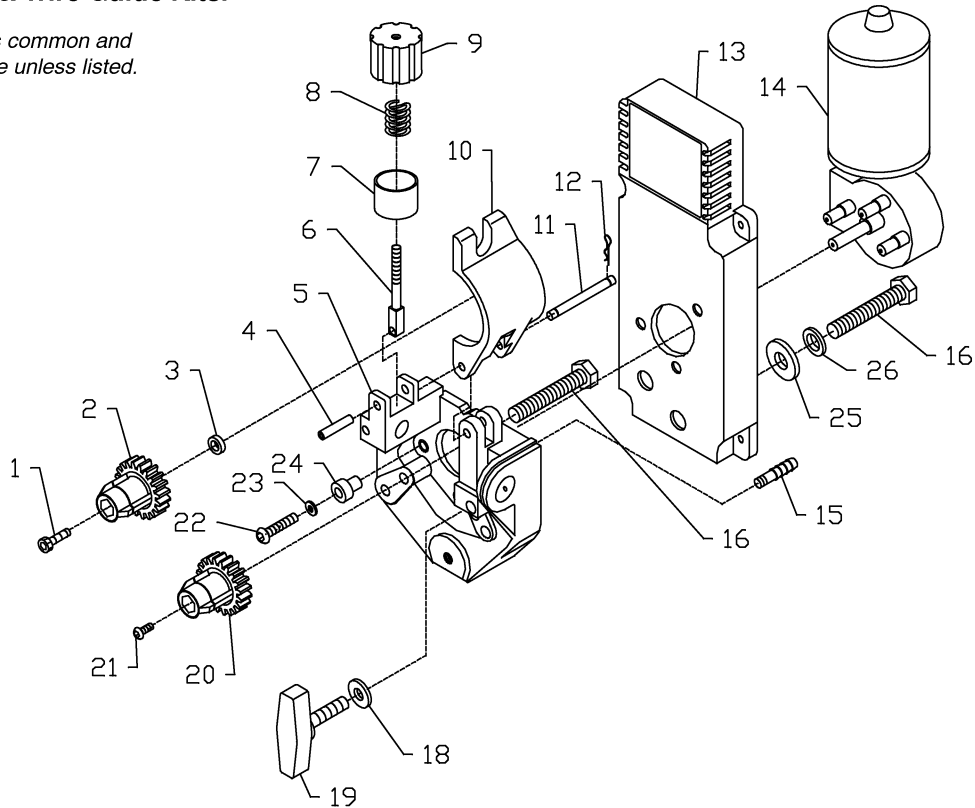

Figure 6-3. Wire Drive And Gears

148 529-H

Table 6-1. Drive Roll And Wire Guide Kits

► **IMPORTANT:** Base selection of drive rolls upon the following recommended usages:

1. V-Grooved rolls for hard wire.
2. U- Grooved rolls for soft and soft shelled cored wires.
3. U-Cogged rolls for extremely soft shelled wires (usually hard surfacing types).
4. V-Knurled rolls for hard shelled cored wires.
5. Drive roll types may be mixed to suit particular requirements (example: V-Knurled roll in combination with U-Grooved).

Wire Diameter			Kit No.	Drive Roll		Inlet Wire Guide
Fraction	Decimal	Metric		Part No.	Type	
.023/.025 in.	.023/.025 in.	0.6 mm	087 131	087 130	V-Grooved	056 192
.030 in.	.030 in.	0.8 mm	079 594	053 695	V-Grooved	056 192
.035 in.	.035 in.	0.9 mm	079 595	053 700	V-Grooved	056 192
.045 in.	.045 in.	1.2 mm	079 596	053 697	V-Grooved	056 193

Ref. S-0026-B/7-91

Item No.	Dia. Mkgs.	Part No.	Description	Quantity
----------	------------	----------	-------------	----------

Figure 6-3. Wire Drive And Gears (Fig 6-2 Item 28)

...	1	602 009	.. SCREW, .250-20 x 1.25 soc hd gr 8	1
...	2	172 075	.. CARRIER, drive roll w/components	1
...	3	166 072	.. SPACER, gear	1
...	4	010 224	.. PIN, spring CS .187 x 1.000	1
...	5	182 788	.. HOUSING, adapter gun/feeder	1
...	6	085 242	.. FASTENER, pinned	1
...	7	196 896	.. CUP, spring	1
...	8	196 897	.. SPRING, cprsn .695 OD x .095 wire	1
...	9	196 895	.. KNOB, tension adj	1
...	10	166 071	.. LEVER, mtg pressure gear	1
...	11	079 634	.. PIN, hinge	1
...	12	151 828	.. PIN, cotter hair .054 x .750	2
...	13	173 616	.. COVER, right angle motor	1
...	14	PM	.. MOTOR, gear 24VDC 122RPM 20:1 ratio (consisting of)	1
...		193 633	.. KEY, woodruff .118 x .380	1
...		193 634	.. WASHER, wave .405 ID x .740 OD	2
...		193 635	.. RING, rtng ext .394 shaft x	1
...	15	079 633	.. FITTING, hose brs barbed M 3/16tbg	1
...	16	601 966	.. SCREW, .375-16 x 1.25hexhd	2
...	18	604 538	.. WASHER, flat stl SAE .312	1
...	19	124 778	.. KNOB, plstc T 1.000 lg x .312-18 x 2.000 bar	1
...	20	173 619	.. CARRIER, drive roll w/components	1
...	21	174 609	.. SCREW, M 4-.7 x 12	1
...	22	174 610	.. SCREW, M 6-1.0 x 20 soc hd	3
...	23	192 029	.. WASHER, flat .250 ID x .437 OD	3
...	24	173 620	.. BUSHING, motor mtg	3
...	25	602 243	.. WASHER, flat .438 ID X 1.00 OD	1
...	26	602 213	.. WASHER, lock .380 ID X .683 OD	1
...		*045 233	.. GUIDE, anti-wear	1

*Recommended Spare Parts.

◆OPTIONAL

To maintain the factory original performance of your equipment, use only Manufacturer's Suggested Replacement Parts. Model and serial number required when ordering parts from your local distributor.

☞ Hardware is common and not available unless listed.

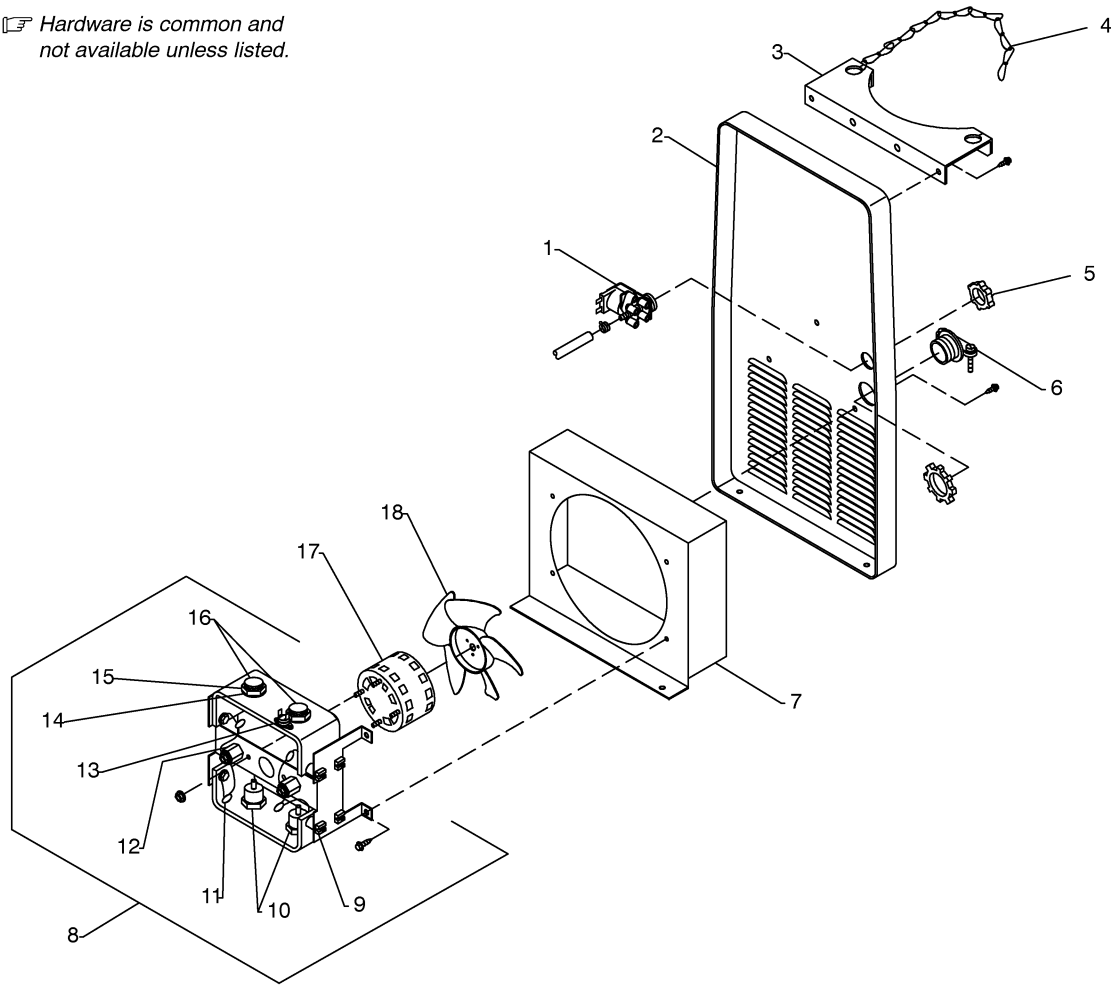

ST-802 288

Figure 6-4. Panel, Rear w/Components

Item No.	Dia. Mkgs.	Part No.	Description	Quantity
Figure 6-4. Panel, Rear w/Components (Fig 6-1 Item 7)				
1		116 996	VALVE, 115 VAC 2way	1
2		143 810	PANEL, rear	1
3		169 654	BRACKET, support tank	1
4		602 387	CHAIN, cyl racks	1
5		605 227	NUT, 750-14 knurled 1.68 dia x .41 h	1
6		178 126	CONNECTOR, clamp cable .690/1.070	1
7		152 627	BRACKET, mtg windtunnel	1
8	SR1	152 742	RECTIFIER, si diode (consisting of)	1
9		152 862	GROMMET, SCR .250 panel hole .3	8
10	D3, D4	037 957	DIODE, rect 275A 300V RP DO-9	2
11	C1-C4	048 420	CAPACITOR, cer disc .01u	4
12		026 947	STAND-OFF, INSLU .250-20 X 1.0	2
13	TP1	171 600	THERMOSTAT, NC open 230F	1
14		605 886	WASHER, tooth .769 ID x 1.24 OD	4
15		605 884	NUT, .750-16 1.12 hex .44H stl plated	4
16	D1, D2	037 956	DIODE, rect 275A 300V SP DO-9	2
17	FM1	148 808	MOTOR, fan 230V 50/60 Hz	1
18		150 783	BLADE, fan 9.00 5wg 39 degree	1

To maintain the factory original performance of your equipment, use only Manufacturer's Suggested Replacement Parts. Model and serial number required when ordering parts from your local distributor.

Hardware is common and not available unless listed.

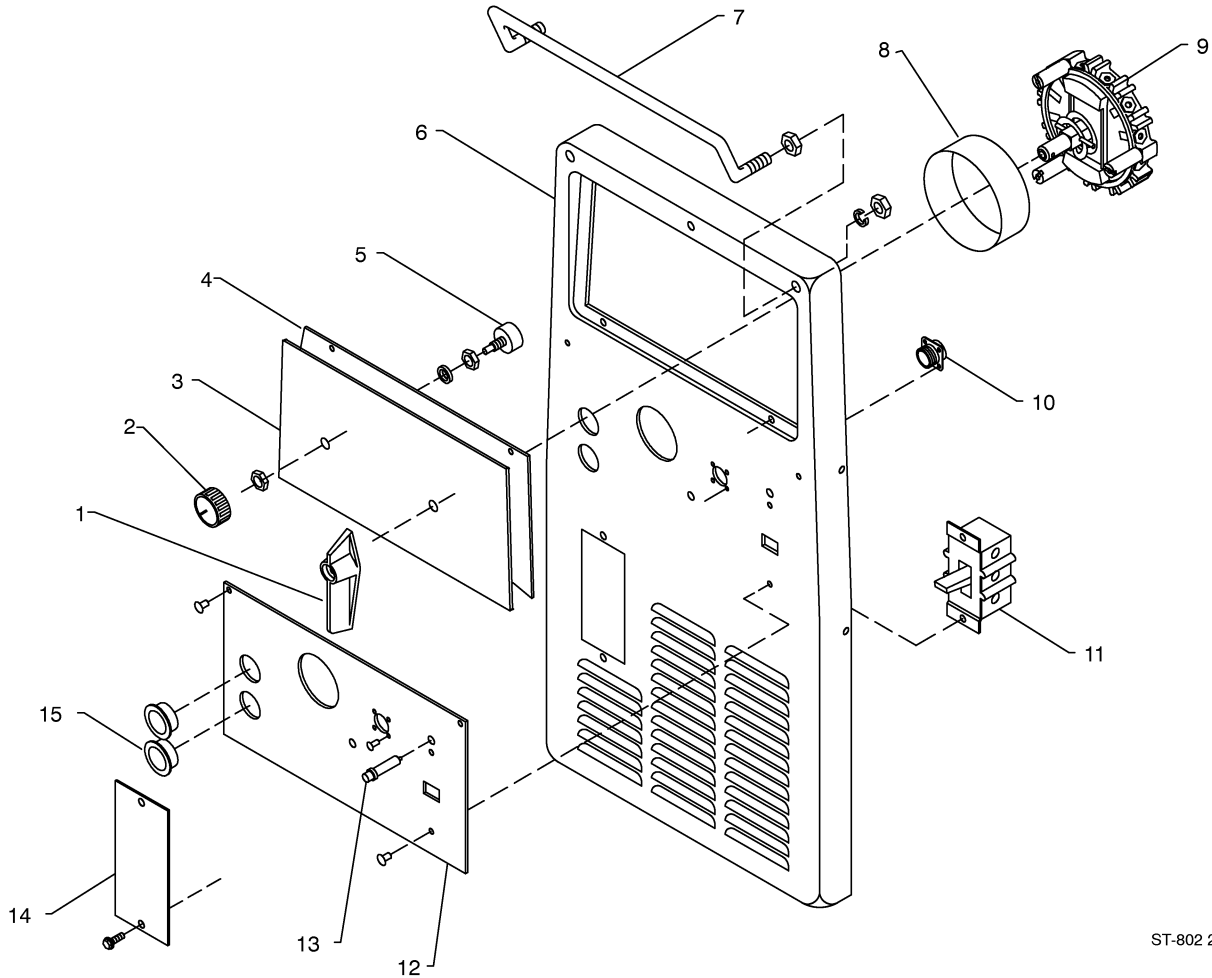

ST-802 287

Figure 6-5. Panel, Front w/Components

Item No.	Dia. Mkgs.	Part No.	Description	Quantity
----------	------------	----------	-------------	----------

Figure 6-5. Panel, Front w/Components (Fig 6-1 Item 19)

.. 1		148 956	.. HANDLE, switch	1
.. 2		097 924	.. KNOB, pointer 1.625 dia x .250 ID w/setscrew	1
.. 3		171 639	.. PLATE, control	1
.. 4		155 418	.. PANEL, front control	1
.. 5	R2	035 897	.. POTENTIOMETER, CP STD slot 1T 2W 1K linear	1
.. 6		175 060	.. PANEL, front	1
.. 7		143 974	.. HANDLE, running gear	1
.. 8		186 058	.. COVER, dust	1
.. 9	S2	153 197	.. SWITCH, selector 6 position (when ordering this part, order 186058 also) ..	1
.. 10	RC1	048 282	.. RECEPTACLE W/SOCKETS	1
.. 11	S1	128 755	.. SWITCH, tgl dpst 40 A 600 VAC	1
.. 12 NAMEPLATE (order by model and serial number)	1
.. 13	PL1	160 775	.. LIGHT, ind wht lens 115 VAC high hat	1
.. 14		144 127	.. COVER, opening module	1
.. 15		057 357	.. BUSHING, snap-in nyl .937 ID x 1.125 mtg hole	2

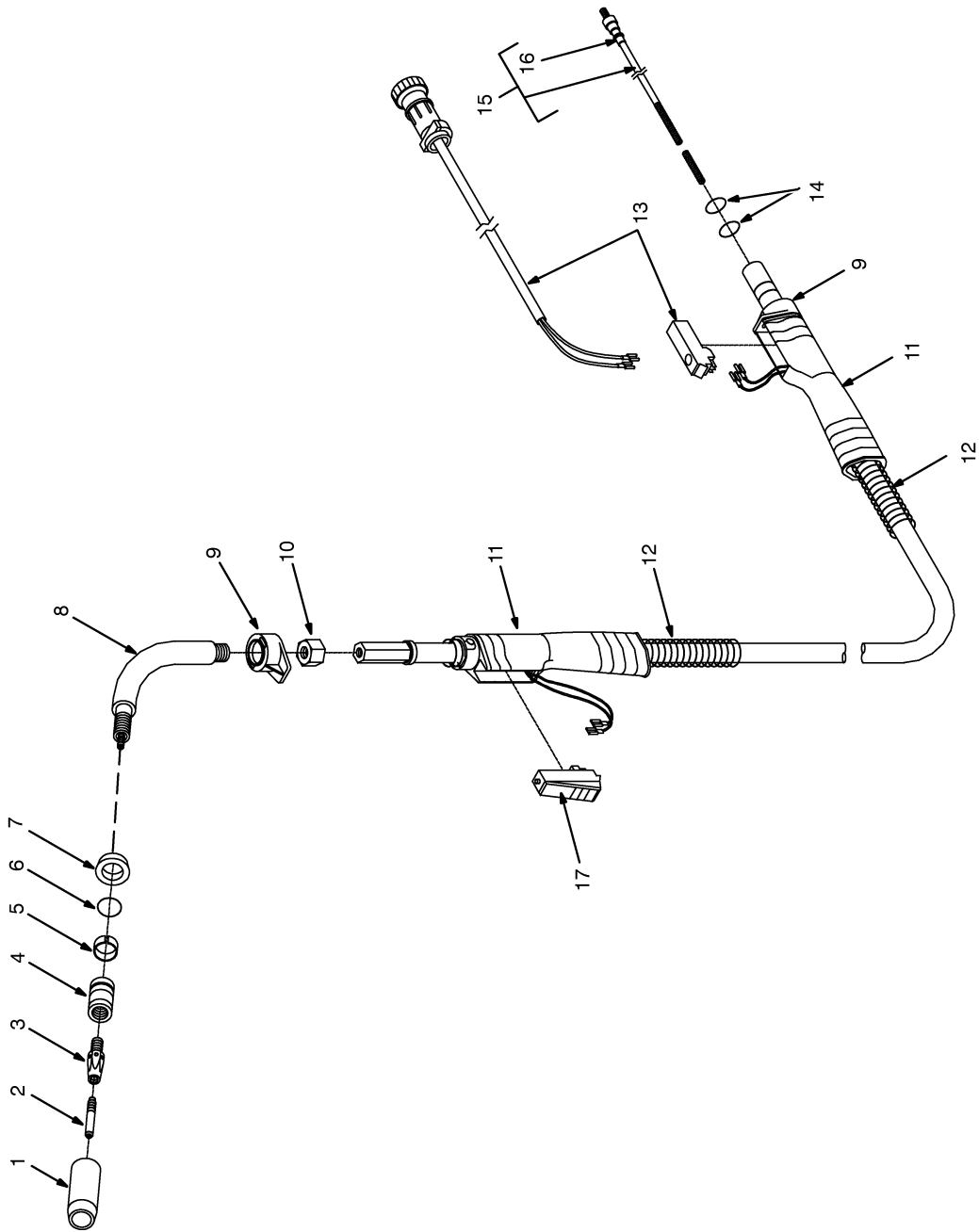

Ref. 800 792-B

Figure 6-6. Exploded View Of Gun

Item No.	Part No.	Description	Quantity
----------	----------	-------------	----------

Figure 6-6. Exploded View Of Gun (Fig 1 Item 20)

...	1	...	◆169 724	..	NOZZLE, slip type .500 orf .125 recess	
...	1	...	◆169 725	..	NOZZLE, slip type .625 orf .125 recess	
...	1	169 726	..	NOZZLE, slip type .625 orf flush	1
...	1	...	◆169 727	..	NOZZLE, slip type .625 orf .125 stickout	
...	2	...	◆087 299	..	TIP, contact scr .023 wire x 1.125	
...	2	...	◆000 067	..	TIP, contact scr .030 wire x 1.125	
...	2	...	◆000 068	..	TIP, contact scr .035 wire x 1.125	
...	2	...	◆000 069	..	TIP, contact scr .045 wire x 1.125	
...	3	169 728	..	ADAPTER, contact tip	1
...	4	169 729	..	ADAPTER, nozzle	1
...	5	170 467	..	RING, retaining	1
...	6	170 468	..	O-RING	1
...	7	169 730	..	WASHER, shock	1
...	8	169 731	..	TUBE, head	1
...	9	169 738	..	NUT, locking handle	2
...	10	194 523	..	NUT, jam	1
...	11	169 737	..	HANDLE	2
...	12	169 741	..	STRAIN RELIEF, cable	2
...	13	180 433	..	CORD, trigger assembly	1
...	14	079 974	..	O-RING, .500 ID x .103CS rbr	2
...	15	...	◆194 010	..	LINER, monocoil .023/.025 wire x 15ft (consisting of)	1
...	15	...	◆194 011	..	LINER, monocoil .030/.035 wire x 15ft (consisting of)	1
...	15	...	◆194 012	..	LINER, monocoil .035/.045 wire x 15ft (consisting of)	1
...	16	079 975	...	O-RING, .187 ID x .103CS rbr	1
...	17	196 255	..	SWITCH, trigger	1

◆OPTIONAL

To maintain the factory original performance of your equipment, use only Manufacturer's Suggested Replacement Parts. Model and serial number required when ordering parts from your local distributor.

TRUE BLUE® WARRANTY

Effective January 1, 2000

(Equipment with a serial number preface of "LA" or newer)

This limited warranty supersedes all previous Miller warranties and is exclusive with no other guarantees or warranties expressed or implied.

Warranty Questions?

Call
1-800-4-A-MILLER
for your local
Miller distributor.

Your distributor also gives you ...

Service

You always get the fast, reliable response you need. Most replacement parts can be in your hands in 24 hours.

Support

Need fast answers to the tough welding questions? Contact your distributor. The expertise of the distributor and Miller is there to help you, every step of the way.

LIMITED WARRANTY - Subject to the terms and conditions below, Miller Electric Mfg. Co., Appleton, Wisconsin, warrants to its original retail purchaser that new Miller equipment sold after the effective date of this limited warranty is free of defects in material and workmanship at the time it is shipped by Miller. THIS WARRANTY IS EXPRESSLY IN LIEU OF ALL OTHER WARRANTIES, EXPRESS OR IMPLIED, INCLUDING THE WARRANTIES OF MERCHANTABILITY AND FITNESS.

Within the warranty periods listed below, Miller will repair or replace any warranted parts or components that fail due to such defects in material or workmanship. Miller must be notified in writing within thirty (30) days of such defect or failure, at which time Miller will provide instructions on the warranty claim procedures to be followed.

Miller shall honor warranty claims on warranted equipment listed below in the event of such a failure within the warranty time periods. All warranty time periods start on the date that the equipment was delivered to the original retail purchaser, or one year after the equipment is sent to a North American distributor or eighteen months after the equipment is sent to an International distributor.

1. 5 Years Parts - 3 Years Labor
 - * Original main power rectifiers
 - * Inverters (input and output rectifiers only)
2. 3 Years — Parts and Labor
 - * Transformer/Rectifier Power Sources
 - * Plasma Arc Cutting Power Sources
 - * Semi-Automatic and Automatic Wire Feeders
 - * Inverter Power Supplies
 - * Intellitig
 - * Engine Driven Welding Generators
(NOTE: Engines are warranted separately by the engine manufacturer.)
3. 1 Year — Parts and Labor
 - * Motor Driven Guns (w/exception of Spoolmate 185)
 - * Process Controllers
 - * Positioners and Controllers
 - * Automatic Motion Devices
 - * Robots
 - * RFCS Foot Controls
 - * Induction Heating Power Sources
 - * Water Coolant Systems
 - * HF Units
 - * Grids
 - * Maxstar 140
 - * Spot Welders
 - * Load Banks
 - * SDX Transformers
 - * Miller Cyclomatic Equipment
 - * Running Gear/Trailers
 - * Plasma Cutting Torches (except APT, ZIPCUT & PLAZCUT Models)
 - * Field Options
(NOTE: Field options are covered under True Blue® for the remaining warranty period of the product they are installed in, or for a minimum of one year — whichever is greater.)
4. 6 Months — Batteries
5. 90 Days — Parts
 - * MIG Guns/TIG Torches

- * Induction Heating Coils and Blankets
- * APT, ZIPCUT & PLAZCUT Model Plasma Cutting Torches
- * Remote Controls
- * Accessory Kits
- * Replacement Parts (No labor)
- * Spoolmate 185

Miller's True Blue® Limited Warranty shall not apply to:

1. Items furnished by Miller, but manufactured by others, such as engines or trade accessories. These items are covered by the manufacturer's warranty, if any.
2. Consumable components; such as contact tips, cutting nozzles, contactors, brushes, slip rings, relays or parts that fail due to normal wear.
3. Equipment that has been modified by any party other than Miller, or equipment that has been improperly installed, improperly operated or misused based upon industry standards, or equipment which has not had reasonable and necessary maintenance, or equipment which has been used for operation outside of the specifications for the equipment.

MILLER PRODUCTS ARE INTENDED FOR PURCHASE AND USE BY COMMERCIAL/INDUSTRIAL USERS AND PERSONS TRAINED AND EXPERIENCED IN THE USE AND MAINTENANCE OF WELDING EQUIPMENT.

In the event of a warranty claim covered by this warranty, the exclusive remedies shall be, at Miller's option: (1) repair; or (2) replacement; or, where authorized in writing by Miller in appropriate cases, (3) the reasonable cost of repair or replacement at an authorized Miller service station; or (4) payment of or credit for the purchase price (less reasonable depreciation based upon actual use) upon return of the goods at customer's risk and expense. Miller's option of repair or replacement will be F.O.B., Factory at Appleton, Wisconsin, or F.O.B. at a Miller authorized service facility as determined by Miller. Therefore no compensation or reimbursement for transportation costs of any kind will be allowed.

TO THE EXTENT PERMITTED BY LAW, THE REMEDIES PROVIDED HEREIN ARE THE SOLE AND EXCLUSIVE REMEDIES. IN NO EVENT SHALL MILLER BE LIABLE FOR DIRECT, INDIRECT, SPECIAL, INCIDENTAL OR CONSEQUENTIAL DAMAGES (INCLUDING LOSS OF PROFIT), WHETHER BASED ON CONTRACT, TORT OR ANY OTHER LEGAL THEORY.

ANY EXPRESS WARRANTY NOT PROVIDED HEREIN AND ANY IMPLIED WARRANTY, GUARANTY OR REPRESENTATION AS TO PERFORMANCE, AND ANY REMEDY FOR BREACH OF CONTRACT TORT OR ANY OTHER LEGAL THEORY WHICH, BUT FOR THIS PROVISION, MIGHT ARISE BY IMPLICATION, OPERATION OF LAW, CUSTOM OF TRADE OR COURSE OF DEALING, INCLUDING ANY IMPLIED WARRANTY OF MERCHANTABILITY OR FITNESS FOR PARTICULAR PURPOSE, WITH RESPECT TO ANY AND ALL EQUIPMENT FURNISHED BY MILLER IS EXCLUDED AND DISCLAIMED BY MILLER.

Some states in the U.S.A. do not allow limitations of how long an implied warranty lasts, or the exclusion of incidental, indirect, special or consequential damages, so the above limitation or exclusion may not apply to you. This warranty provides specific legal rights, and other rights may be available, but may vary from state to state.

In Canada, legislation in some provinces provides for certain additional warranties or remedies other than as stated herein, and to the extent that they may not be waived, the limitations and exclusions set out above may not apply. This Limited Warranty provides specific legal rights, and other rights may be available, but may vary from province to province.





Owner's Record

Please complete and retain with your personal records.

Model Name

Serial/Style Number

Purchase Date

(Date which equipment was delivered to original customer.)

Distributor

Address

City

State

Zip



Resources Available

Always provide Model Name and Serial/Style Number.

Contact your Distributor for:

To locate a distributor or service agency near you, call 1-800-4-A-Miller or visit our website at www.MillerWelds.com

Welding Supplies and Consumables

Options and Accessories

Personal Safety Equipment

Service and Repair

Replacement Parts

Training (Schools, Videos, Books)

Technical Manuals (Servicing Information and Parts)

Circuit Diagrams

Welding Process Handbooks

Contact the Delivering Carrier for:

For assistance in filing or settling claims, contact your distributor and/or equipment manufacturer's Transportation Department.

File a claim for loss or damage during shipment.

Miller Electric Mfg. Co.

An Illinois Tool Works Company
1635 West Spencer Street
Appleton, WI 54914 USA

International Headquarters - USA

USA Phone: 920-735-4505 Auto-Attended
USA & Canada FAX: 920-735-4134
International FAX: 920-735-4125

European Headquarters - United Kingdom

Phone: 44 (0) 1204-593493
FAX: 44 (0) 1204-596066

www.MillerWelds.com



Miller
The Power of Blue.