

April 1976

FORM: OM-1301B

Effective with serial No. HF876062

| MODEL | STOCK NO. |
|-----------------|-----------|
| MILLERMATIC 35 | 057 436 |
| MILLERMATIC 35S | 057 469 |

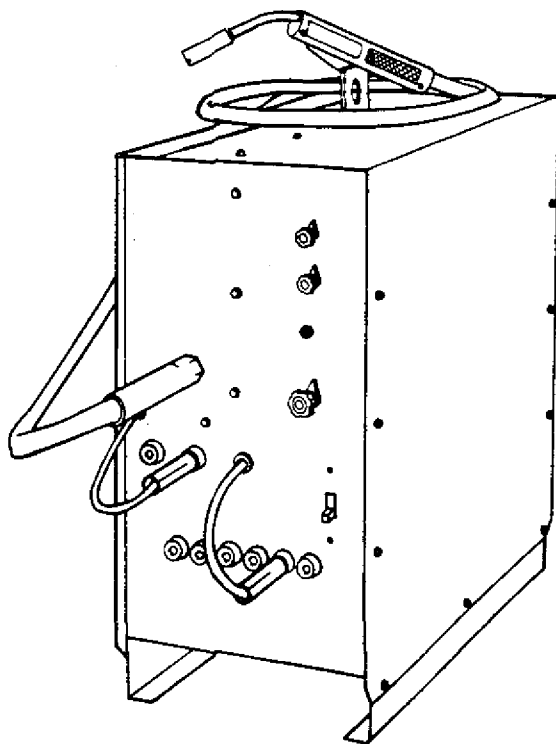

| MODEL/STOCK NO. | SERIAL/STYLE NO. | DATE PURCHASED |
|-----------------|------------------|----------------|
| | | |

OWNER'S MANUAL



MILLER ELECTRIC MFG. CO.
APPLETON, WISCONSIN, USA 54911

WARRANTY

MILLER Electric Mfg. Co., Appleton, Wisconsin, warrants all new equipment to be free from defects in material and factory workmanship for the periods indicated below, provided the equipment is installed and operated according to manufacturer's instructions.

MILLER Electric Mfg. Co.'s obligation, under this warranty, is limited to replacing or repairing any defective part or correcting any manufacturing defect without charge during the warranty period if MILLER's inspection confirms the existence of such defects. MILLER's option of repair or replacement will be f.o.b. factory at Appleton, Wisconsin or f.o.b. a MILLER authorized service facility, and therefore no compensation for transportation costs of any kind will be allowed.

The warranty period, beginning on the date of sale to the original purchaser-user of the equipment, will be for ninety days on the MILLERMATIC portion of this welding machine. The MILLERMATIC portion includes all drive train parts starting at the inlet guide bushing and going up to the contact tip, including the gun, drive roll assembly, All other parts, with the exception of the main rectifier diodes, carry a one year warranty. The four diodes used in the main rectifier carry a three year UNCONDITIONAL WARRANTY.

MILLER Electric Mfg. Co. will not be liable for any loss or consequential damage or expense accruing directly or indirectly from the use of equipment covered in this warranty.

This warranty supersedes all previous MILLER warranties and is exclusive with no other guarantees or warranties expressed or implied.

IMPORTANT

Use of parts, not manufactured or recommended by MILLER, in the power or wire feed portions of this unit including the gun assembly voids the warranty.

ERRATA SHEET

After this manual was printed, refinements in equipment design occurred. This sheet lists exceptions to data appearing later in this manual.

AMENDMENT TO TABLE 3-1:

Table 3-1. Recommended Primary Wire & Fuse Sizes

| Primary Wire Size – AWG | | | | Fuse Size In Amperes | | | |
|-------------------------|--------------------|--------------------|--------------------|----------------------|-------|-------|-------|
| 208 V | 230 V | 460 V | 575 V | 208 V | 230 V | 460 V | 575 V |
| No. 10 (No. 10) | No. 10 (No. 10) | No. 14 (No. 14) | No. 14 (No. 14) | 40 | 35 | 20 | 15 |

*Input conductor sizes are based on allowable ampacities of insulated copper conductors, having a temperature rating of 75°C, with not more than three conductors in a raceway or cable. Numbers in () indicate ground conductor sizes.

AMENDMENT TO FIGURE 6-1:

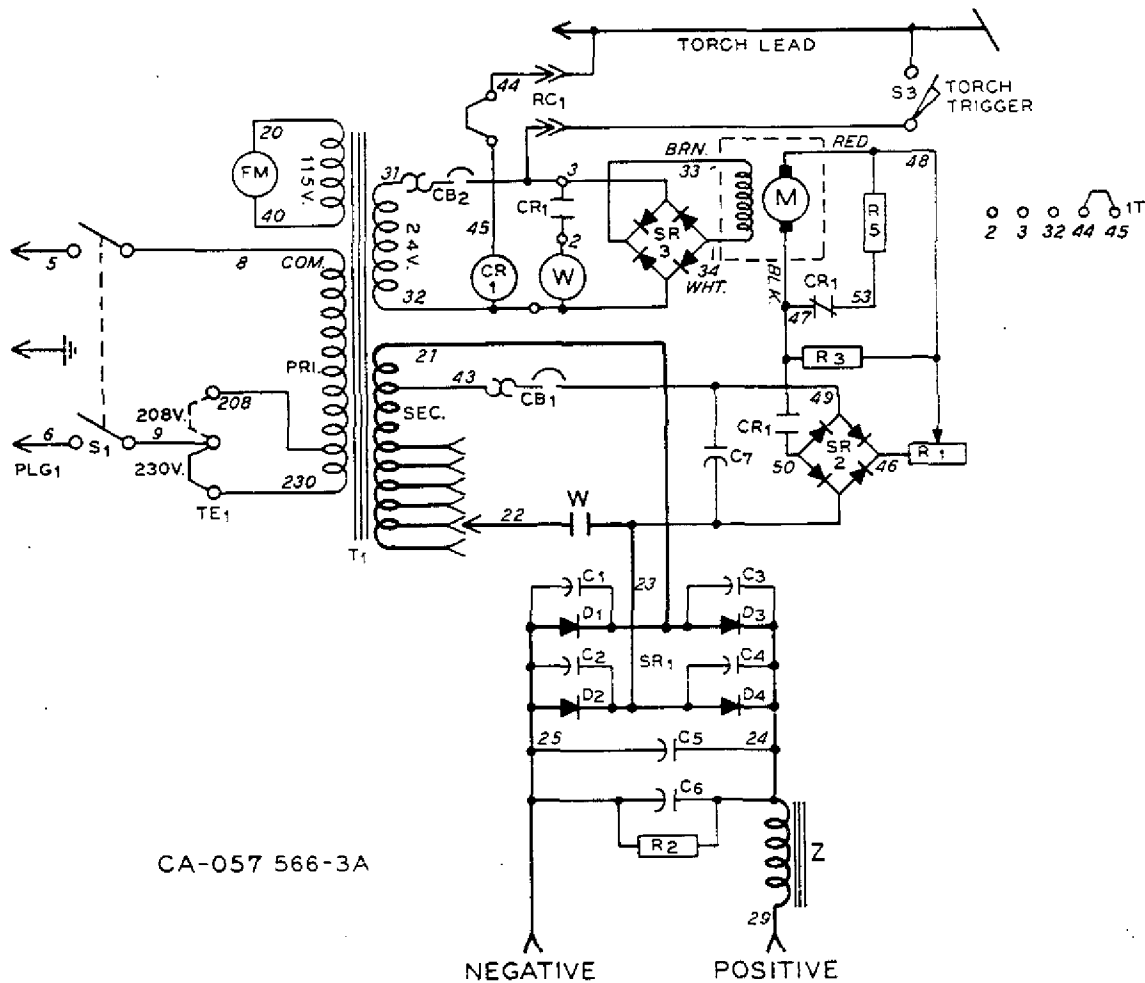

CA-057 566-3A

Circuit Diagram No. CA-057 566-3A

NOTE

This unit is equipped with a 115 volt fan motor. If transformer T1 (007 685) or transformer coil (007 684) must be replaced, use the above part number to order the replacement part. The 115 volt fan motor may be replaced by a 230 volt motor (032 678) providing the 230 volt motor is connected to lead No. 8 and lead No. 20 on the primary side of transformer T1.

Figure 6-1. Circuit Diagram For Model Without Spot Panel Effective With Serial No. HG057413 And On

TABLE OF CONTENTS

Section No.

Page No.

SECTION 1 – SAFETY RULES FOR OPERATION OF ARC WELDING POWER SOURCE

| | |
|--------------------------------------|---|
| 1 - 1. Introduction | 1 |
| 1 - 2. General Precautions | 1 |
| 1 - 3. Arc Welding | 3 |
| 1 - 4. Standards Booklet Index | 4 |

SECTION 2 – INTRODUCTION

| | |
|---------------------------------|---|
| 2 - 1. General | 5 |
| 2 - 2. Receiving-Handling | 5 |
| 2 - 3. Description | 6 |
| 2 - 4. Safety | 6 |

SECTION 3 – INSTALLATION

| | |
|---|----|
| 3 - 1. Installation Of Welding Power Source On Running Gear | 6 |
| 3 - 2. Location | 7 |
| 3 - 3. Primary Connections | 8 |
| 3 - 4. Work Cable Assembly | 8 |
| 3 - 5. Gas Connections | 9 |
| 3 - 6. Installation Of Welding Wire Spool | 9 |
| 3 - 7. Threading The Welding Wire | 10 |

SECTION 4 – SEQUENCE OF OPERATION

| | |
|------------------------------------|----|
| 4 - 1. Gas Metal-Arc Welding | 10 |
| 4 - 2. Gas Metal-Arc Welding | 11 |

SECTION 5 – MAINTENANCE

| | |
|---|----|
| 5 - 1. Wire Feed Calibration | 13 |
| 5 - 2. Monocoil | 13 |
| 5 - 3. Removal of Drive Roll Gears | 14 |
| 5 - 4. Installation of Drive Roll Gears | 14 |
| 5 - 5. Circuit Breakers | 14 |

SECTION 6 – TROUBLESHOOTING

PARTS LIST

SECTION 1 - SAFETY RULES FOR OPERATION OF ARC WELDING POWER SOURCE

1-1. INTRODUCTION

We learn by experience. Learning safety through personal experience like a child touching a hot stove is harmful, wasteful, and unwise. Let the experience of others teach you.

Safe practices developed from experience in the use of welding and cutting are described in this manual. Research, development, and field experience have evolved reliable equipment and safe installation, operation, and servicing practices. Accidents occur when equipment is improperly used or maintained. The reason for the safe practices may not always be given. Some are based on common sense, others may require technical volumes to explain. It is wiser to follow the rules.

Read and understand these safe practices before attempting to install, operate, or service the equipment. Comply with these procedures as applicable to the particular equipment used and their instruction manuals, for personal safety and for the safety of others.

Failure to observe these safe practices may cause serious injury or death. When safety becomes a habit, the equipment can be used with confidence.

Responsibilities of installer, user, and serviceman. Installation, operation, checking, and repair of this equipment must be done only by a competent person, experienced with such equipment.

These safe practices are divided into two Sections: 1 - General Precautions, common to arc welding and cutting; and 2 - Arc Welding (and Cutting)(only).

Reference standards: Published Standards on safety are also available for additional and more complete procedures than those given in this manual. They are listed in the Standards Index in these safety rules. ANSI Z49.1 is the most complete.

The National Electrical Code, Occupation Safety and Health Administration, local industrial codes, and local inspection requirements also provide a basis for equipment installation, use, and service.

1-2. GENERAL PRECAUTIONS

A. Burn Prevention

Wear protective clothing - leather (or asbestos) gauntlet gloves, hat, and high safety-toe shoes. Button shirt collar and pocket flaps, and wear cuffless trousers to avoid entry of sparks and slag.

Wear helmet with safety goggles or glasses with side shields underneath, appropriate filter lenses or plates (protected by clear cover glass). This is a **MUST** for welding or cutting, (and chipping) to protect the eyes from radiant energy and flying metal. Replace cover glass when broken, pitted, or spattered. See 1-3A.

Avoid oily or greasy clothing. A spark may ignite them.

Hot metal such as electrode stubs and workpieces should never be handled without gloves.

Medical first aid and eye treatment. First aid facilities and a qualified first aid person should be available for each shift unless medical facilities are close by for immediate treatment of flash burns of the eyes and skin burns.

Ear plugs should be worn when working on overhead or in a confined space. A hard hat should be worn when others work overhead.

Flammable hair preparations should not be used by persons intending to weld or cut.

B. Toxic Fume Prevention

Adequate ventilation. Severe discomfort, illness or death can result from fumes, vapors, heat, or oxygen enrichment or depletion that welding (or cutting) may produce. Prevent them with adequate ventilation as described in ANSI Standard Z49.1 listed 1 in Standards index. NEVER ventilate with oxygen.

Lead, cadmium, zinc, mercury, and beryllium bearing and similar materials, when welded (or cut) may produce harmful concentrations of toxic fumes. Adequate local exhaust ventilation must be used, or each person in the area as well as the operator must wear an air-supplied respirator. For beryllium, both must be used.

Metals coated with or containing materials that emit toxic fumes should not be heated unless coating is removed from the work surface, the area is well ventilated, or the operator wears an air-supplied respirator.

Work in a confined space only while it is being ventilated and, if necessary, while wearing an air-supplied respirator.

Gas leaks in a confined space should be avoided. Leaked gas in large quantities can change oxygen concentration dangerously. Do not bring gas cylinders into a confined space.

Leaving confined space, shut OFF gas supply at source. The space will then be safe to re-enter, if downstream valves have been accidentally opened or left open.

Vapors from chlorinated solvents can be decomposed by the heat of the arc (or flame) to form PHOSGENE, a highly toxic gas, and other lung and eye irritating products. The ultraviolet (radiant) energy of the arc can also decompose trichloroethylene and perchloroethylene vapors to form phosgene. DO NOT WELD or cut where solvent vapors can be drawn into the welding or cutting atmosphere or where the radiant energy can penetrate to atmospheres containing even minute amounts of trichloroethylene or perchloroethylene.

C. Fire and Explosion Prevention

Causes of fire and explosion are: combustibles reached by the arc, flame, flying sparks, hot slag or heated material; misuse of compressed gases and cylinders; and short circuits.

Be aware that flying sparks or falling slag can pass through cracks, along pipes, through windows or doors, and through wall or floor openings, out of sight of the goggled operator. Sparks and slag can fly 35 feet.

To prevent fires and explosion:

Keep equipment clean and operable, free of oil, grease, and (in electrical parts) of metallic particles that can cause short circuits.

If combustibles are in area, do NOT weld or cut. Move the work if practicable, to an area free of combustibles. Avoid paint spray rooms, dip tanks, storage areas, ventilators. If the work can not be moved, move combustibles at least 35 feet away out of reach of sparks and heat; or protect against ignition with suitable and snug-fitting, fire-resistant covers or shields.

Walls touching combustibles on opposite sides should not be welded on (or cut). Walls, ceilings, and floor near work should be protected by heat-resistant covers or shields.

Fire watcher must be standing by with suitable fire extinguishing equipment during and for some time after welding or cutting if:

- appreciable combustibles (including building construction) are within 35 feet
- appreciable combustibles are further than 35 feet but can be ignited by sparks
- openings (concealed or visible) in floors or walls within 35 feet may expose combustibles to sparks
- combustibles adjacent to walls, ceilings, roofs, or metal partitions can be ignited by radiant or conducted heat.

Hot work permit should be obtained before operation to ensure supervisor's approval that adequate precautions have been taken.

After work is done, check that area is free of sparks, glowing embers, and flames.

An empty container that held combustibles, or that can produce flammable or toxic vapors when heated, must never be welded on or cut, unless container has first been cleaned as described in AWS Standard A6.0, listed 3 in Standards index.

This includes: a thorough steam or caustic cleaning (or a solvent or water washing, depending on the combustible's solubility) followed by purging and inerting with nitrogen or carbon dioxide, and using protective equipment as recommended in A6.0. Waterfilling just below working level may substitute for inerting.

A container with unknown contents should be cleaned (see paragraph above). Do NOT depend on sense of smell or sight to determine if it is safe to weld or cut.

Hollow castings or containers must be vented before welding or cutting. They can explode.

Explosive atmospheres. Never weld or cut where the air may contain flammable dust, gas, or liquid vapors (such as gasoline).

D. Compressed Gas Equipment

Standard precautions. Comply with precautions in this manual, and those detailed in CGA Standard P-1, PRECAUTIONS FOR SAFE HANDLING OF COMPRESSED GASES IN CYLINDERS, listed 6 in Standards index.

1. Pressure Regulators

Regulator relief valve is designed to protect only the regulator from overpressure; it is not intended to protect any downstream equipment. Provide such protection with one or more relief devices.

Never connect a regulator to a cylinder containing gas other than that for which the regulator was designed.

Remove faulty regulator from service immediately for repair (first close cylinder valve). The following symptoms indicate a faulty regulator:

Leaks - if gas leaks externally.

Excessive Creep - if delivery pressure continues to rise with downstream valve closed.

Faulty Gauge - if gauge pointer does not move off stop pin when pressurized, nor returns to stop pin after pressure release.

Repair. Do NOT attempt repair. Send faulty regulators for repair to manufacturer's designated repair center, where special techniques and tools are used by trained personnel.

2. Cylinders

Cylinders must be handled carefully to prevent leaks and damage to their walls, valves, or safety devices:

Avoid electrical circuit contact with cylinders including third rails, electrical wires, or welding circuits. They can produce short circuit arcs that may lead to a serious accident. (See 1-3C.)

ICC or DOT marking must be on each cylinder. It is an assurance of safety when the cylinder is properly handled.

Identifying gas content. Use only cylinders with name of gas marked on them; do not rely on color to identify gas content. Notify supplier if unmarked. NEVER DEFACE or alter name, number, or other markings on a cylinder. It is illegal and hazardous.

Empties: Keep valves closed, replace caps securely; mark MT; keep them separate from FULLS and return promptly.

Prohibited use. Never use a cylinder or its contents for other than its intended use, NEVER as a support or roller.

Secure from falling. Chain or secure cylinders upright when a regulator (and hose) are connected to it.

Passageways and work areas. Keep cylinders clear of areas where they may be struck.

Transporting cylinders. With a crane, use a secure support such as a platform or cradle. Do NOT lift cylinders off the ground by their valves or caps, or by chains, slings, or magnets.

Do NOT expose cylinders to excessive heat, sparks, slag, and flame, etc. that may cause rupture. Do not allow contents to exceed 130°F. Cool with water spray where such exposure exists.

Protect cylinders particularly valves from bumps, falls, falling objects, and weather. Replace caps securely when moving cylinders.

Stuck valve. Do NOT use a hammer or metal wrench to open a cylinder valve that can not be opened by hand. Notify your supplier.

Mixing gases. Never try to mix any gases in a cylinder.

Never refill any cylinder.

Cylinder fittings should never be modified or exchanged.

3. Hose

Prohibited use. Never use hose other than that designed for the specified gas. A general hose identification rule is: red for fuel gas, green for oxygen, and black for inert gases.

Use ferrules or clamps designed for the hose (not ordinary wire or other substitute) as a binding to connect hoses to fittings.

No copper tubing splices. Use only standard brass fittings to splice hose.

Avoid long runs to prevent kinks and abuse. Suspend hose off ground to keep it from being run over, stepped on, or otherwise damaged.

Coil excess hose to prevent kinks and tangles.

Protect hose from damage by sharp edges, and by sparks, slag, and open flame.

Examine hose regularly for leaks, wear, and loose connections. Immerse pressured hose in water; bubbles indicate leaks.

Repair leaky or worn hose by cutting area out and splicing (1-2D3). Do NOT use tape.

4. Proper Connections

Clean cylinder valve outlet of impurities that may clog orifices and damage seats before connecting regulator. Except for hydrogen, crack valve momentarily, pointing outlet away from people and sources of ignition. Wipe with a clean lintless cloth.

Match regulator to cylinder. Before connecting, check that the regulator label and cylinder marking agree, and that the regulator inlet and cylinder outlet match. NEVER CONNECT a regulator designed for a particular gas or gases to a cylinder containing any other gas.

Tighten connections. When assembling threaded connections, clean and smooth seats where necessary. Tighten. If connection leaks, disassemble, clean, and retighten. For metal-to-metal seating, use correct wrenches, available from your supplier. For O-ring connections, hand tighten.

Adapters. Use a CGA adapter (available from your supplier) between cylinder and regulator, if one is required. Use two wrenches to tighten adapter marked RIGHT and LEFT HAND threads.

Regulator outlet (or hose) connections may be identified by right hand threads for oxygen and left hand threads (with grooved hex on nut or shank) for fuel gas.

5. Pressurizing Steps:

Drain regulator of residual gas through suitable vent before opening cylinder (or manifold valve) by turning adjusting screw in (clockwise). Draining prevents excessive compression heat at high pressure seat by allowing seat to open on pressurization. Leave adjusting screw engaged slightly on single-stage regulators.

Before opening cylinder valve, check that hoses are connected and that downstream valves are closed.

Stand to side of regulator while opening cylinder valve.

Open cylinder valve slowly so that regulator pressure increases slowly. When gauge is pressurized (gauge reaches regulator maximum) leave cylinder valve in following position: For oxygen, and inert gases, open fully to seal stem against

possible leak. For fuel gas, open to less than one turn to permit quick emergency shutoff.

Use pressure charts (available from your supplier) for safe and efficient, recommended pressure settings on regulators. It will reduce backfiring and chance of flashbacks.

Check for leaks on first pressurization and regularly thereafter. Brush with soap solution (capful of Ivory Liquid* or equivalent per gallon of water). Bubbles indicate leak. Clean off soapy water after test; dried soap is combustible.

E. User Responsibilities

Remove leaky or defective equipment from service immediately and repair them only if recommended in equipment instruction manual. Send others for repair to manufacturer's designated repair center where special techniques and tools are used by trained personnel. Refer to User Responsibilities statement in equipment manual.

F. Leaving Equipment Unattended

Close gas supply at source and drain gas.

G. Rope Staging-Support

Rope staging-support should not be used for welding or cutting operation; rope may burn.

1-3. ARC WELDING

Comply with precautions in 1-2 and this section. Arc Welding, properly done, is a safe process, but a careless operator invites trouble. The equipment carries high currents at significant voltages. The arc is very bright and hot. Sparks fly, fumes rise, ultraviolet and infrared energy radiates, weldments are hot, and compressed gases may be used. The wise operator avoids unnecessary risks and protects himself and others from accidents. Precautions are described here and in standards referenced in index.

A. Burn Protection

Comply with precautions in 1-2.

The welding arc is intense and visibly bright. Its radiation can damage eyes, penetrate lightweight clothing, reflect from light-colored surfaces, and burn the skin and eyes. Skin burns resemble acute sunburn, those from gas-shielded arcs are more severe and painful. **DON'T GET BURNED; COMPLY WITH PRECAUTIONS.**

1. Protective Clothing

Wear long-sleeve clothing (particularly for gas-shielded arc) in addition to gloves, hat, and shoes (1-2A). As necessary, use additional protective clothing such as leather jacket or sleeves, flame-proof apron, and fire-resistant leggings. Avoid outer garments of untreated cotton.

Bare skin protection. Wear dark, substantial clothing. Button collar to protect chest and neck and button pockets to prevent entry of sparks.

2. Eye and Head Protection

Protect eyes from exposure to arc. NEVER look at an electric arc without protection.

Welding helmet or shield containing a filter plate shade no. 9 or denser must be used when welding. Place over face before striking arc.

Protect filter plate with a clear cover plate.

Cracked or broken helmet or shield should NOT be worn; radiation can pass through to cause burns.

Cracked, broken, or loose filter plates must be replaced IMMEDIATELY. Replace clear cover plate when broken, pitted, or spattered.

Flash goggles with side shields MUST be worn under the helmet to give some protection to the eyes should the helmet not be lowered over the face before an arc is struck. Looking at an arc momentarily with unprotected eyes (particularly a high intensity gas-shielded arc) can cause a retinal burn that may leave a permanent dark area in the field of vision.

3. Protection of Nearby Personnel

Enclosed welding area. For production welding, a separate room or enclosed bay is best. In open areas, surround the operation with low-reflective, non-combustible screens or panels. Allow for free air circulation, particularly at floor level.

Viewing the weld. Provide face shields for all persons who will be looking directly at the weld.

Others working in area. See that all persons are wearing flash goggles.

Before starting to weld, make sure that screen flaps or bay doors are closed.

B. Toxic Fume Prevention

Comply with precautions in 1-2B.

Generator engine exhaust must be vented to the outside air. Carbon monoxide can kill.

C. Fire and Explosion Prevention

Comply with precautions in 1-2C.

Equipment's rated capacity. Do not overload arc welding equipment. It may overheat cables and cause a fire.

Loose cable connections may overheat or flash and cause a fire.

Never strike an arc on a cylinder or other pressure vessel. It creates a brittle area that can cause a violent rupture or lead to such a rupture later under rough handling.

D. Compressed Gas Equipment

Comply with precautions in 1-2D.

E. Shock Prevention

Exposed hot conductors or other bare metal in the welding circuit, or in ungrounded, electrically-HOT equipment can fatally shock a person whose body becomes a conductor. **DO NOT STAND, SIT, LIE, LEAN ON, OR TOUCH** a wet surface when welding, without suitable protection.

To protect against shock:

Keep body and clothing dry. Never work in damp area without adequate insulation against electrical shock. Stay on a dry duckboard, or rubber mat when dampness or sweat can not be avoided. Sweat, sea water, or moisture between body and an electrically HOT part - or grounded metal - reduces the body surface electrical resistance, enabling dangerous and possibly lethal currents to flow through the body.

1. Grounding the Equipment

When installing, connect the frames of each unit such as welding power source, control, work table, and water circulator to the building ground. Conductors must be adequate to carry ground currents safely. Equipment made electrically HOT by stray current may shock, possibly fatally. Do NOT GROUND to electrical conduit, or to a pipe carrying ANY gas or a flammable liquid such as oil or fuel.

Three-phase connection. Check phase requirement of equipment before installing. If only 3-phase power is available, connect single-phase equipment to only two wires of the 3-phase line. Do NOT connect the equipment ground lead to the third (live) wire, or the equipment will become electrically HOT - a dangerous condition that can shock, possibly fatally.

Before welding, check ground for continuity. Be sure conductors are touching bare metal of equipment frames at connections.

If a line cord with a ground lead is provided with the equipment for connection to a switchbox, connect the ground lead to the grounded switchbox. If a three-prong plug is added for connection to a grounded mating receptacle, the ground lead must be connected to the ground prong only. If the line cord comes with a three-prong plug, connect to a grounded mating receptacle. Never remove the ground prong from a plug, or use a plug with a broken off ground prong.

*Trademark of Proctor & Gamble.

2. Electrode Holders

Fully insulated electrode holders should be used. Do NOT use holders with protruding screws.

3. Connectors

Fully insulated lock-type connectors should be used to join welding cable lengths.

4. Cables

Frequently inspect cables for wear, cracks and damage. IMMEDIATELY REPLACE those with excessively worn or damaged insulation to avoid possibly - lethal shock from bared cable. Cables with damaged areas may be taped to give resistance equivalent to original cable. Keep cable dry, free of oil and grease, and protected from hot metal and sparks.

5. Terminals

Terminals and other exposed parts of electrical units should have insulating covers secured before operation.

6. Electrode Wire

Electrode wire becomes electrically HOT when the power switch of gas metal-arc welding equipment is ON and welding gun trigger is pressed. Keep hands and body clear of wire and other HOT parts.

7. Safety Devices

Safety devices such as interlocks and circuit breakers should not be disconnected or shunted out.

Before installation, inspection, or service, of equipment, shut OFF all power and remove line fuses (or lock or red-tag switches) to prevent accidental turning ON of power. Disconnect all cables from welding power source, and pull all 115 volts line-cord plugs.

Do not open power circuit or change polarity while welding. If, in an emergency, it must be disconnected, guard against shock burns, or flash from switch arcing.

Leaving equipment unattended. Always shut OFF and disconnect all power to equipment.

Power disconnect switch must be available near the welding power source.

1-4. STANDARDS BOOKLET INDEX

For more information, refer to the following standards or their latest revisions and comply as applicable:

1. ANSI Standard Z49.1, SAFETY IN WELDING AND CUTTING obtainable from the American Welding Society, 2501 NW 7th St., Miami, Fla. 33125.
2. ANSI Standard Z87.1, SAFE PRACTICE FOR OCCUPATION AND EDUCATIONAL EYE AND FACE PROTECTION, obtainable from American National Standards Institute, 1430 Broadway, New York, N.Y. 10018.
3. American Welding Society Standard A6.0, WELDING AND CUTTING CONTAINERS WHICH HAVE HELD COMBUSTIBLES, obtainable same as item 1.
4. NFPA Standard 51, OXYGEN-FUEL GAS SYSTEMS FOR WELDING AND CUTTING, obtainable from the National Fire Protection Association, 470 Atlantic Avenue, Boston, Mass. 02210.
5. NFPA Standard 51B, CUTTING AND WELDING PROCESSES, obtainable same as item 4.
6. CGA Pamphlet P-1, SAFE HANDLING OF COMPRESSED GASES IN CYLINDERS, obtainable from the Compressed Gas Association, 500 Fifth Avenue, New York, N. Y. 10036.
7. OSHA Standard 29 CFR, Part 1910, Subpart Q, WELDING, CUTTING AND BRAZING.

SECTION 2 - INTRODUCTION

| Model | Rated Welding Current Amperes 60% Duty Cycle | Open-Circuit Volts | Power Input at Rated Load 60 Hz, Single-Phase | | | | Dimensions Inches | | | Weight Pounds | | | |
|---|---|--------------------|--|-----------|-----|-----|---------------------------|---------|-------|--------------------|----------|-----------------|----------|
| | | | Amperes | | kva | kw | Height | Width | Depth | Without Spot Panel | | With Spot Panel | |
| | | | 208 Volts | 230 Volts | | | | | | Net | Shipping | Net | Shipping |
| 150 Ampere With And Without Spot Panel | 150 Amps @ 23 Volts | 32 | 26.5 | 24 | 5.5 | 4.8 | 30" | 13-1/2" | 27" | 170 | 180 | 175 | 185 |
| | | | | | | | Dimensions Centimeters | | | Weight Kilos | | | |
| | | | | | | | 76.20 | 34.29 | 68.6 | 77.110 | 81.646 | 79.378 | 83.914 |

Figure 2-1. Specifications

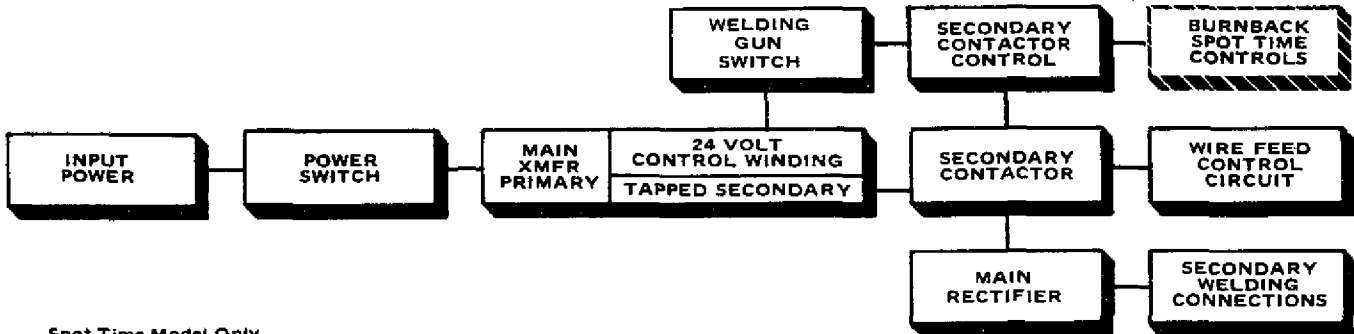

--- Spot Time Model Only

Figure 2-2. Block Diagram

TA-057 469-2

2-1. GENERAL

This manual has been prepared especially for use in familiarizing personnel with the design, installation, operation, maintenance, and troubleshooting of this equipment. All information presented herein should be given careful consideration to assure optimum performance of this equipment.

2-2. RECEIVING-HANDLING

Prior to installing this equipment, clean all packing material from around the unit and carefully inspect for any damage that may have occurred during shipment. Any claims for loss or damage that may have occurred in transit must be filed by the purchaser with the carrier. A copy of the bill of lading and freight bill will be furnished by the carrier on request if occasion to file claim arises.

When requesting information concerning this equipment, it is essential that Model Description and/or Stock Number and Serial (or Style) Numbers of the equipment be supplied.

Parts which are included with this welding machine are as follows.

- A. 1 - Nozzle, continuous weld
- B. 1 - Nozzle, inside corner spot
- C. 1 - Nozzle, flat spot
- D. 1 - Nozzle, outside corner spot
- E. 2 - Contact tubes for .035" wire
- F. 3 - Contact tubes for .030" wire
- G. 5 - Contact tube compression sleeve
- H. 1 - Regulator w/CO₂ inlet stem & nut
- I. 1 - Argon regulator inlet stem & nut*
- J. 1 - Washer for CO₂ cylinder connection

Jackplug assembly includes:

- K. 1 - Tie wire
- L. 1 - Copper contact strip
- M. 1 - Fillister head screw
- N. 2 - Allen screws
- O. 1 - Brass jack plug
- P. 1 - Fiber insulator tube
- R. 1 - Primary Wall Receptacle
- S. 1 - Work cable
- T. 1 - Work cable clamp
- 1 - Assembly Instruction sheet

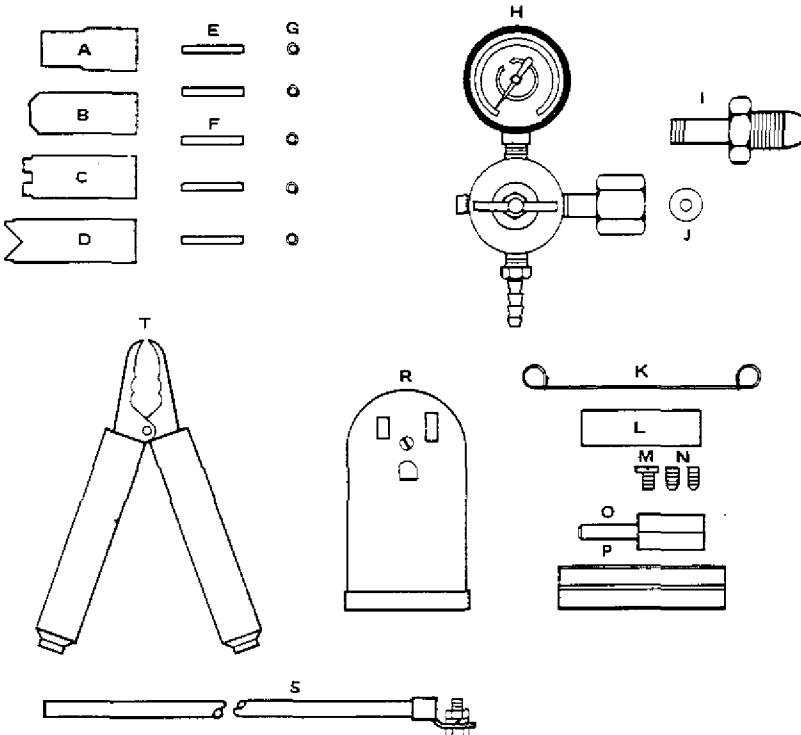

TB-057 469-13

*Replacement regulator inlet nut and stem for welding applications requiring Argon-CO₂ mixture.

2-3. DESCRIPTION

This constant potential welding power source is of the silicon diode rectifier dc type, designed for the Gas Metal-Arc Welding (GMAW) process.

This welding power source consists of a single-phase power transformer, stabilizer, rectifier, cooling fan, facilities for remote contactor control, a built-in control/feeder, and gun with all necessary interconnecting cables. Spot panel models are equipped with a spot panel which has facilities for controlling spot weld time and spot burnback time.

2-4. SAFETY

Before attempting to make primary or secondary connections, change parts or make repairs, be sure the welding power source is completely disconnected from the main power line.

A precautionary measure should be taken to provide maximum protection against electrical shock. Before electrical connections are made from the switch, be sure that the line disconnect switch has been opened or the fuses have been removed and remain that way until the installation has been completed.

Caution should be exercised in taking voltage measurements when troubleshooting the unit. Always avoid contact between any part of the human body and any current carrying part of the welding power source.

Before the equipment is put into operation, the safety section at the front of this manual should be read completely. This will help avoid possible injury due to misuse or improper welding applications.

The following definitions apply to CAUTION, IMPORTANT, and NOTE blocks found throughout this manual:

CAUTION

Under this heading, installation, operating, and maintenance procedures or practices will be found that if not carefully followed may create a hazard to personnel.

IMPORTANT

Under this heading, installation, operating, and maintenance procedures or practices will be found that if not carefully followed may result in damage to equipment.

NOTE

Under this heading, explanatory statements will be found that need special emphasis to obtain the most efficient operation of the equipment.

SECTION 3 - INSTALLATION

TOOLS REQUIRED FOR SETUP

- 3/32" Allen Wrench
- 1/4 to 3/8" Steel Rod 10 to 12" Long
- Side Cutters
- 3/8, 7/16 & 9/16" Box or Open End Wrenches
- 1/2 & 3/4" Open End Wrench
- 10" or Larger Adjustable Wrench
- Pliers
- Screw Driver - Medium Size
- Cutting Knife

3-1. INSTALLATION OF THE WELDING POWER SOURCE ON RUNNING GEAR (Optional) (See Figure 3-1).

NOTE

Prior to installing the running gear to the welding power source, remove the shipping boards which are attached to the machine's base. Use a 7/16 inch wrench to remove the bolts and nuts which secure the boards to the base.

The Following Items are Required for a Complete Setup

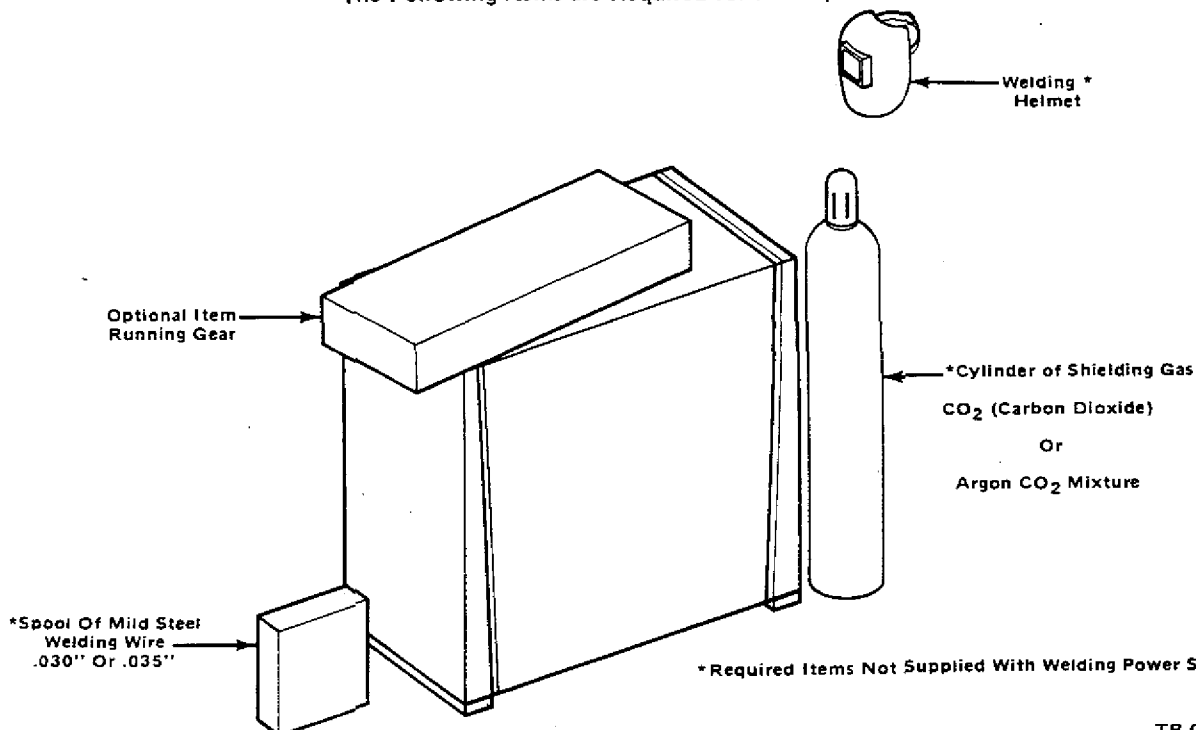

1. Remove running gear from carton.
2. Install the two 4" swivel wheels by placing the bolt of each one through the 1/2" diameter holes provided in the frame. Place lock washer (2A) and nut (2B) on bolt and use 3/4" wrench to tighten.
3. Place 3/4" flat washer (3A) on rear axle, place wheel (3B) on axle, place washer (3C) on axle, insert cotter pin (3D) through hole provided in axle. Spread pin to lock. Install other rear wheel using same procedure.
4. Place the welding power source on running gear with large wheels to the rear of the welding power source, align mounting holes in running gear with mounting holes in the welding power source base. Insert one 1/4-20 x 1" (4) bolt through bottom of running gear and the welding power source. Place lock washer (4A) and nut (4B) on bolt several turns, but do not tighten.

Install the other three bolts in the same manner. When all bolts are installed, tighten the four nuts securely.

5. Use 3/8" wrench to remove screws (5A) and (5B) from top of the welding power source. Put handle (No. 5) in place as shown and replace the screws just removed through the handle into the welding power source. Tighten securely.
6. At rear of the welding power source two holes with weld nuts inside are provided for the attachment of the cylinder bracket (7). Use two 3/8-18 x 3/4" long cap screws (7A) to secure bracket to welder case, place flange down. Tighten securely.
7. Place gas cylinder in rack and lock in with safety chain (8). Cylinder must be secured at all times.

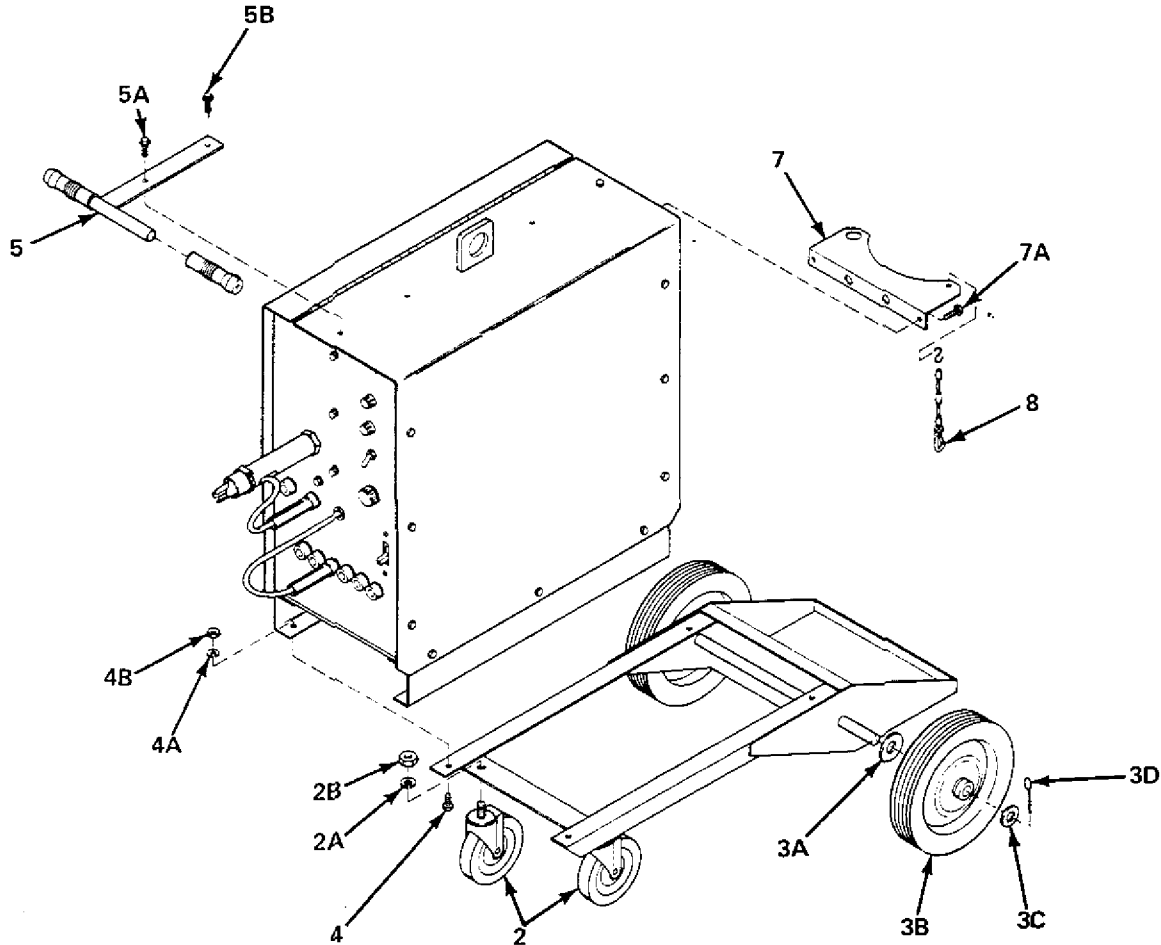

Figure 3-1. Installation of Running Gear

TD-040 873-1

3-2. LOCATION (Figure 3-2)

A good installation is essential if the welding power source is to provide satisfactory and dependable service. Proper operating temperatures are maintained by the air stream produced by the welding power source fan unit.

The welding power source should be located so that the air passage from the rear of the welding power source will not be restricted. Therefore the back of the welding power source should be away from a wall or other obstruction, a minimum of 12 inches.

The location should be such that a minimum amount of dust and dirt will be drawn into the air stream. Preventive maintenance consists of removing the wrapper from the welding power source and blowing out the dust accumulation inside the unit. For this reason it is desirable to locate the unit so that the wrapper can be removed without any difficulty. Four mounting holes are provided in the welding power source base for machines that require mounting.

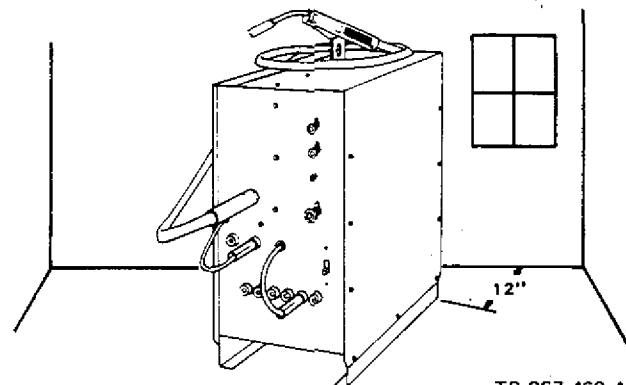

Figure 3-2. Location

TB-057 469-4A

3.3. PRIMARY CONNECTIONS

The welding power source is shipped from the factory set to operate on the highest primary voltage shown on the nameplate.

A unit shipped for 208/230 voltage is set on the 230 voltage.

If your primary voltage supply is other than the highest voltage listed on the front of your welder, you will have to change the jumper linkage located inside the welder following procedures given in step 1 to 5 below.

If the primary voltage available matches the highest voltage of the welder, skip steps 1 to 5.

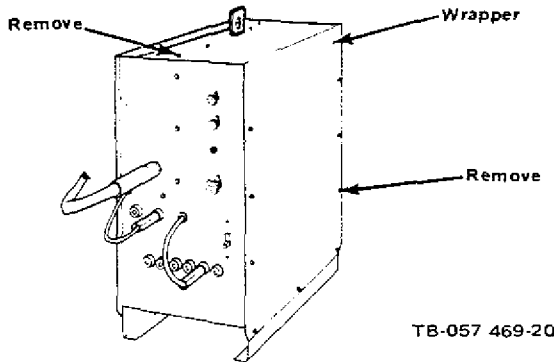

Figure 3-3. Wrapper Cap Screw Location

1. Use a 3/8" wrench to remove the thirteen cap screws from the welding power source. Loosen the screws which secure the door.
2. Lift wrapper upward to remove.
3. Locate Terminal Linkage where indicated in Figure 3-4.

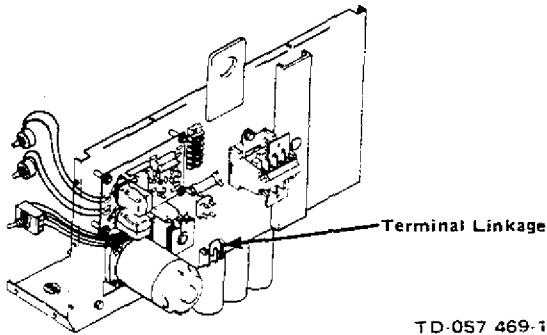

Figure 3-4. Primary Voltage Terminal Strip Location

NOTE

Each welding power source has one terminal block with a position for the jumper link for each voltage listed on the nameplate. The linkage must be connected for the correct voltage.

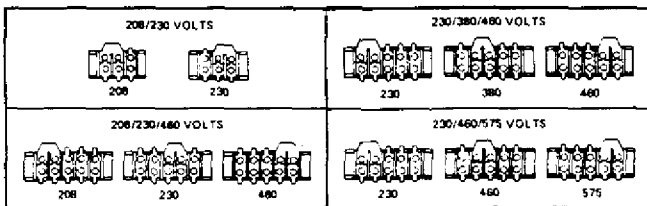

Figure 3-5. Primary Voltage Jumper Link Arrangement

4. Loosen the two screws securing the jumper link and move to position to match primary supply according to the hook-up shown in Figure 3-5. Tighten all screws securely.
5. Replace welder wrapper.

This dc arc welding power source is a single-phase unit and must be connected to a single-phase power line. Consult the

local electric utility if there is any question about the system used locally or the proper connections to connect single-phase power service to the welding power source.

All models are ordinarily equipped with a three conductor power cable. Models requiring 208 or 230 volts primary input are equipped with a three prong polarized plug and wall receptacle. The wall receptacle should be installed in a convenient location by a competent electrician. The wall receptacle should be installed with the grounding terminal at the top. This would allow the power cable to hang downward without undue bending or twisting.

Table 3-1. Recommended Primary Wire & Fuse Sizes

| Primary Wire Size - AWG | | | | Fuse Size In Amperes | | | |
|-------------------------|------------------|-------------------|-------------------|----------------------|-------|-------|-------|
| 208 V | 230 V | 460 V | 575 V | 208 V | 230 V | 460 V | 575 V |
| No. 6 (No. 8) | No. 8 (No. 8) | No. 12 (No. 8) | No. 12 (No. 8) | 56 | 40 | 20 | 15 |

() Indicates Ground Wire Size

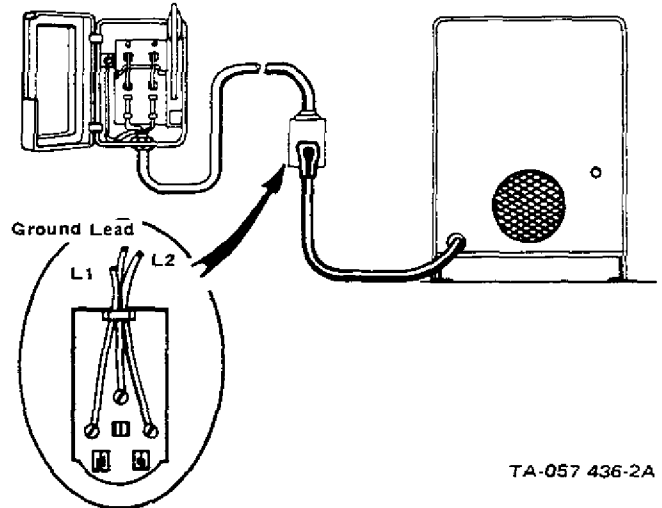

Figure 3-6. Primary Connections

3.4. WORK CABLE ASSEMBLY

A 10 foot work cable with a lug on one end and one plain end is included with each unit.

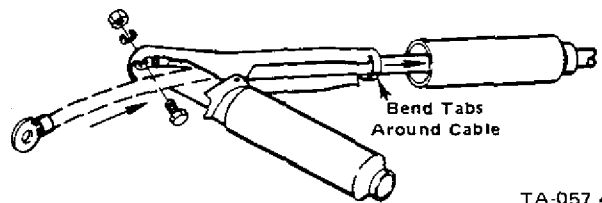

Figure 3-7. Work Clamp Installation

To install the work clamp onto the work cable, proceed as follows:

1. Insert plain end of cable into the clamp above spring until lug lines up with hole in clamp. Install 1/4-20 x 1/2" bolt through lug and clamp, replace lock washer and nut, and use 7/16" wrench to tighten.
2. Use pliers to bend tabs around cable as shown.
3. Slide insulating sleeve on cable and over clamp as shown. Install remaining sleeve on other clamp handle.

The jack plug, included in the parts package, must be attached to the plain end of the work lead cable as follows:

1. Remove 1 inch of insulation from end of cable.
2. Clamp the cable in a vise with the un-insulated end protruding upward out of the vise approximately 1-3/4 inches.
3. Place the steel tie wire approximately 1/4 inch from the end of the insulation.

- Disengage tension spring on drive assembly and open upper drive housing as shown in Fig. 3-11.

NOTE

Spooled wire has a tendency to unravel when loosened from the spool. Maintain a firm grip on the wire during the threading operation.

- Loosen end of wire from spool and cut off any kinked or bent portion with side cutters. The cut must be a good clean cut to avoid binding in the drive system.
- Thread the wire through the stub liner of the lower drive housing. Feed it several inches into the gun monocoil liner.

IMPORTANT

Whenever the upper portion of the drive assembly is closed, ensure that the gears are properly meshed and the wire is placed in the groove of the drive rolls. Failure to comply with this requirement will result in erratic wire feed and damage to the drive rolls.

- Lower the upper portion of the drive assembly, making sure the gears are properly meshed and the wire is placed in the groove of the drive roll. Reposition tension spring in locked position.
- Close the welding power source door panel. Keep closed as much as possible to protect wire from dust and contamination.

3-7. THREADING THE WELDING WIRE

- Remove weld nozzle from gun by a slight pull.
- Check contact tube to match wire size.

- The wire size .030" or .035" is stamped on side of contact tube. If size matches wire, replace weld nozzle.
- If contact tube change is required, remove compression nut (5) (Fig. 3-12) with 7/16" wrench, turn in counterclockwise direction.

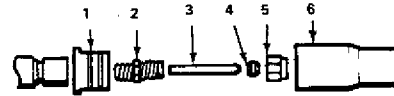

TA-057 469-18

Figure 3-12. Contact Tube Installation

- Remove contact tube (3) from connector (2) by pulling out. The compression sleeve (No. 4) remains on the tube.
- Select correct size contact tube from parts package included with the welding power source and push it into the connector (2) as far as possible. Slide compression sleeve over tube until it is tight against the connector.
- Replace compression nut over the contact tube and tighten.
- Replace weld nozzle.
- Turn the primary disconnect switch and the welding power source POWER switch to ON position. Fan will start.
- Press gun trigger and hold in until the wire extends about 1/4" out of the contact tube. Make sure the gas is flowing.

If excess wire feeds out, cut off to 1/4" length with side cutters.

SECTION 4 - SEQUENCE OF OPERATION

4-1. GAS METAL-ARC WELDING (Models without spot welding capability).

A. General

Read and thoroughly understand these instructions before attempting to operate this equipment.

Before attempting to weld on a finished piece of work, it is recommended that practice welds be made on sample metal the same as that of the finished work piece.

It is recommended that of all the weld positions this equipment is capable of (flat, vertical and overhead), that the beginner experiment with the flat position in making practice welds since this is the easiest to learn.

As with any other electric arc welding process, the metal to be welded should be free of paint, rust or other non-conductive material.

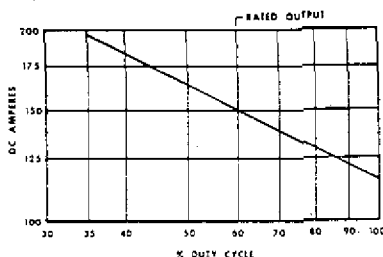

Figure 4-1. Duty Cycle Chart

The duty cycle of a welding power source is the percentage of a ten minute period that a welding power source can safely operate at a given output current setting. This welding power source is rated at 150 amperes at 23 volts, 60 percent duty cycle. This means the welding power source can be safely operated at 150 amperes welding current for six minutes out of every ten. If the welding current is decreased, the duty cycle will increase.

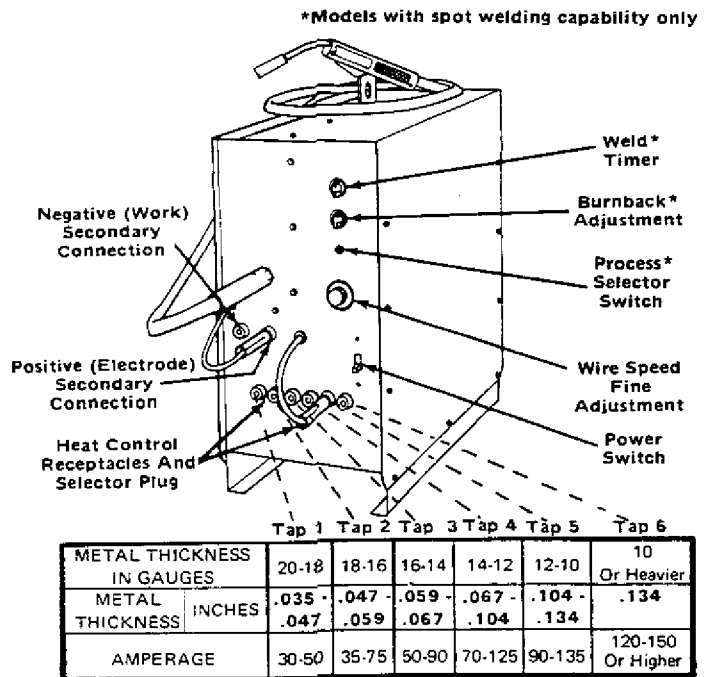

Figure 4-2. Range Selection TB-057 469-4A

The six yellow receptacles on the front of the machine (numbered 1 through 6) provide a selection of heat input to the weld. The higher the numbered tap, the hotter the weld. If practice welding is to be performed on 16 gauge metal, the No. 3 tap provides a good starting point for experimentation. As indicated in the table above, the amperage range at this receptacle can be varied between 50 to 90 amperes which can be adjusted by means of the WIRE SPEED FINE ADJUSTMENT control. A good setting for practice welding would be a setting at 50.

B. Holding The Gun

The gun held in either hand should be at a 45 to 60 degree lead angle. It can also be tilted 45 to 60 degrees away from you. This will give good vision of the arc which is necessary to follow the seam. However, never view the arc directly. Always use a welding helmet with proper filter lens.

A 1/4 to 5/16 inch distance from the bottom side of the gun nozzle to the workpiece must be maintained during the arc starting and welding period. Do not pull the gun back when arc starts. This will create a long wire extension and a very poor weld.

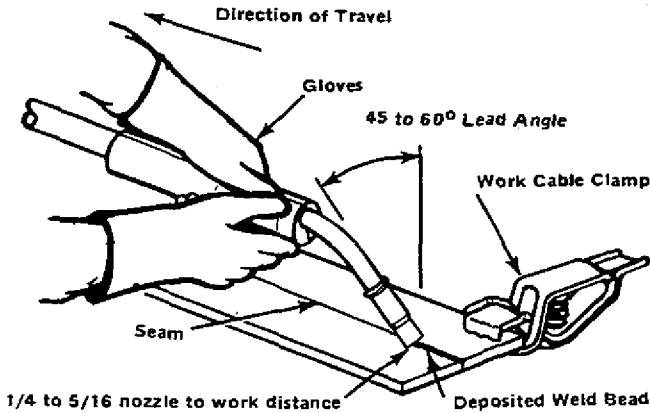

Figure 4-3. Gun Position TA-057 469-11A

Cradle the gun in one hand, then rest side of hand on work piece (avoid doing this on hot material); use other hand to hold gun and control gun trigger.

The wire is cold (not energized) until trigger is pressed, you can position the wire on the seam and hold it there before lowering helmet and pressing the gun trigger.

The gun can be moved along the seam in a steady movement known as the drag technique. (See Fig. 4-4). It can be also oscillated in a full circle a few degrees beyond each side of the seam. Either one is good and the technique desired will be easy for you to select. The speed of travel will be regulated by the type of weld bead required. The average speed is 15 to 20 inches per minute. Refer to Fig. 4-5 for examples of acceptable or improper weld results.

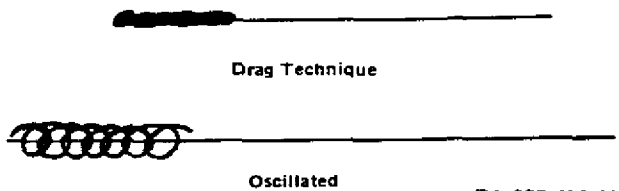

Figure 4-4. Welding Techniques



Figure 4-5. Cross Cut View of Various Welds

C. Pre-Weld Checklist

1. Welding power source POWER switch to "ON".
2. Gas valve opened.
3. Proper heat tap selected.

4. Work clamp connected to work material.
5. Welding helmet on.
6. Wire extended 1/4" beyond gun nozzle.
7. Place wire over seam; remember to hold 1/4" to 5/16" nozzle to work length.
8. Lower welding helmet, and press trigger.

D. Possible Problems

IMPORTANT

The gas nozzle will periodically fill up with weld spatter; this must be cleaned out.

E. Techniques For Vertical And Overhead Welding

For Vertical welding, the arc is started at the top of the seam and pulled downward in a steady drag method. When bridging a gap, the arc can be oscillated from one piece of the work to the other.

Overhead welding is easily done with the same techniques; drag or oscillating along the seam. If the puddle is too fluid (hot) using a given heat tap, move to a lower numbered tap and set the WIRE SPEED FINE ADJUSTMENT control to higher setting as this will aid in cooling puddle.

F. Shutdown Procedures

1. Turn the welding power source OFF.
2. Turn primary disconnect switch to "OFF".
3. Close gas cylinder valve.

NOTE

Gas cylinder valve should be closed when the welding power source is not in periodic use.

4. Press gun trigger "in" to release gas in regulator. The gas pressure indicator will return to 0.

NOTE

When restarting, remember the gas cylinder valve should be opened slowly to avoid excessive shock to the regulator indicator.

4-2. GAS METAL-ARC WELDING (Models with spot welding capability)

A. Metal Preparation

For the best spot welding results, the metal should be clean. Paint and rust should be removed before spotting. The work cable clamp must be attached to parts being welded to insure proper grounding in order to complete a current path.

Spot welds can be made in a variety of methods and in all positions, thru use of the various nozzles supplied in the parts kit.

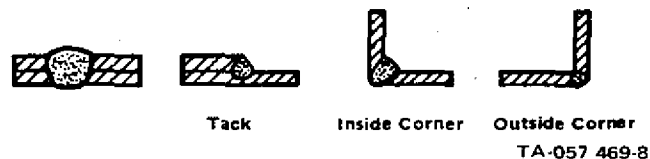

Figure 4-6. Various Spot Welds

If the materials are of different thicknesses, the lightest gauge material should always be spotted to the heavy material. Recommended maximum thickness for the top piece for lap spot is 16 gauge.

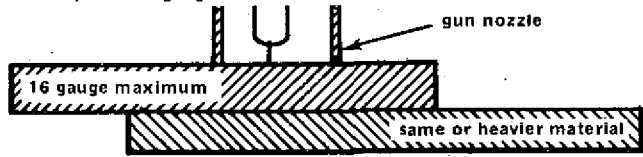

Figure 4-7. Metal Size

TA-057 469-10

For tack, inside corner or outside corner, the maximum material thickness will be determined by your acceptance of sufficient weld.

The .035" wire is best for spotting with this unit. The .030" will work, but not as well.

The gas can be either CO₂ or 75A-25CO₂. The latter is recommended for use with the lighter gauge materials.

B. PROCESS SELECTOR SWITCH

Place in SPOT WELDING position. When the switch is in this position, the WIRE SPEED FINE ADJUSTMENT is inoperative.

C. WELD TIMER

Controls length of weld time.

Set at 50 — about 1 second.
Set at 100 — about 2 seconds.

Once the proper heat tap has been selected, this control will regulate the nugget size and penetration. For set-up purposes, set this control at 50.

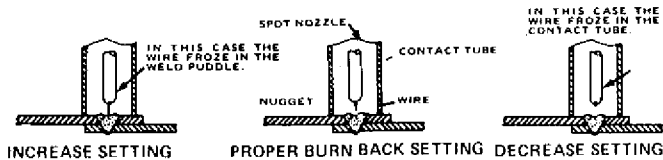

Figure 4-8. Burnback Settings

TD-022 959

D. BURNBACK ADJUSTMENT CONTROL

The burnback circuitry in this control/feeder provides a means of keeping the welding wire from sticking to the work-piece or the contact tube in the gun after the gun switch is released. The burnback capability in this control/feeder will, depending upon the setting of the BURNBACK Control, keep weld current present on the welding wire from 1/64 to 1/4 of a second after the wire has stopped feeding. This delay action will permit the welding wire to burn back to a point where it will neither stick to the workpiece nor the contact tube. If the welding wire sticks to the contact tube in the gun after the gun switch is released, rotate the BURNBACK Control to a setting closer to the 0 (1/64 second) position. If the welding wire sticks to the workpiece after the gun switch is released, rotate the BURNBACK Control to a setting closer to the 10 (1/4 second) position. (See Fig. 4-8).

E. Selecting Heat Tap

Spot welding usually requires a higher number heat tap for given size material than is required for continuous welding. The most generally used taps are No. 4, 5, and 6.

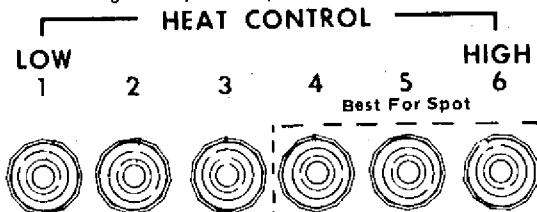

Figure 4-9. Heat Selection

TD-022 959

To start with, use sample materials and set heat in No. 6 tap.

F. Nozzle Selection

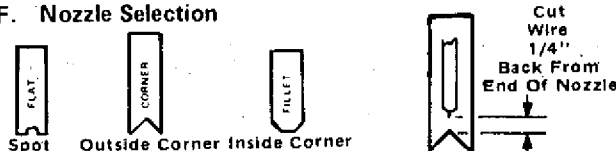

Figure 4-10. Spot Nozzles

Remove continuous weld nozzle from gun. Install spot nozzle. Check that wire is cut back 1/4" from the shortest end of weld nozzle.

G. Pre-Weld Checklist

1. Gas cylinder valve open.
2. Welding power source POWER switch on.
3. Work Lead connected to work piece.

H. Spot Welding

1. Place weld nozzle against work material and press trigger.
2. If arc does not start, re-check work clamp; it must be in contact with material to be welded.
3. If wire sticks in weld puddle, release work clamp, press gun trigger, wire will feed out and raise gun from work; cut wire off close to weld nugget, and 1/4" back of nozzle end, increase BURNBACK ADJUSTMENT Control setting ten degrees.



Not enough weld time or too low of heat tap.



Too much time or too high of heat tap for material.



The nugget has penetrated almost through the bottom piece and the nugget top has remained fairly flat.

Figure 4-11. Various Spot Welds

TA-057 469-8

4. To check a spot weld, pull the two pieces apart. A good weld will tear a small hole out of the bottom piece.
5. If weld pulls apart easily, increase the weld time.
6. For a visual test, examine the reverse side of the spot; if a very dark blue circle or small metal protrusion appears, this indicates a good weld.

I. Checking Wire Stick Out

Wire should stick out of the contact tube 1/8" to 1/4".

If a burnback has occurred, (the wire has burned into the contact tube) decrease the BURNBACK ADJUSTMENT Control setting at least ten degrees.

Contact tube must be removed if a burnback has occurred.

Disconnect Work Clamp from work. Avoid contact with work clamp during following procedure.

Remove nozzle, and compression nut. Pull forward on contact tube and press gun trigger; this will feed faulty tube out. Cut wire behind tube and install new contact tube and compression sleeve. Replace compression nut and weld nozzle.

Re-check the burnback setting. It should be set at a lower time than the time used when burnback occurred.

J. Shutdown Procedures

1. Turn the welding power source OFF.
2. Turn primary disconnect switch to OFF.
3. Close gas cylinder valve (turn off). Gas cylinder should always be closed when machine is not in periodic use.
4. Press gun trigger "in" to release gas in regulator. The gas pressure indicator will return to 0.

NOTE

When re-starting, remember, the gas cylinder valve should be opened slowly.

SECTION 5 - MAINTENANCE

5-1. WIRE FEED CALIBRATION

This welding system is factory calibrated to provide the proper wire feed speed/heat adjustment range for each heat step. Minor variations due to line voltage, wear in, wire stiffness, dirt etc., can normally be accommodated by the WIRE SPEED FINE ADJUSTMENT control. However, this calibration should be checked occasionally and the system recalibrated as necessary. Recalibration will be needed most often during the initial few weeks when the equipment is new and only occasionally, thereafter, depending on use and environment. Calibration is a simple procedure and will ensure full and optimum performance of this equipment.

To check the calibration of this welding system, proceed as follows:

1. Make all connections necessary for continuous welding. Gas is not necessary.
2. Insert the Heat Control Plug into the No. 1 receptacle.
3. Set the WIRE SPEED FINE ADJUSTMENT at MIN.
4. Remove the red jack plug from its receptacle and allow it to hang free. This will prevent the welding wire from being energized.
5. Using a clock or watch sweep second hand, feed wire for a timed interval of 10 seconds.
6. Measure the length of wire fed during the 10 seconds.
7. If the length of wire measures between 7 and 13 inches, the machine is in calibration and no adjustment will be necessary.
8. If more than 13 inches of wire is fed, increase wire spool hub tension by giving the nut on the end of the hub support shaft one or two turns in a clockwise direction.
9. Run the wire for another 10 second interval and measure again.
10. Repeat steps 8 and 9 until the amount of wire fed during the interval is between 7 and 13 inches.
11. If great difficulty is experienced in getting the speed down to 13 inches it may be due to an excessively high line voltage or because the welding power source is improperly connected for the line voltage being used. See paragraph 3-3 for instructions on making proper primary connections.
12. If the wire fed during the timed interval is significantly less than 7 inches repeat steps 8 and 9 except now the tension adjustment nut must be turned in a counterclockwise direction.
13. If the nut is turned full out and the speed remains under 7 inches during the timed 10 second interval, it might indicate a need for routine maintenance or adjustment. The following is a list of some of the probable causes of slow wire feed:
 - a. Incorrect size contact tube. See Paragraph 3-7.
 - b. Tight or damaged contact tube. See paragraph 3-7.
 - c. Hub binding on shaft. See paragraph 3-6.
 - d. Incorrect wire size.
 - e. Worn drive gears. See paragraph 3-5.
 - f. Dirt in monocoil liner. See paragraph 5-2.
 - g. Drive gear housing misaligned. See paragraph 5-3.
 - h. Monocoil loose. See paragraph 5-2.
 - i. Inlet block or monocoil rubbing on drive gears. See paragraph 5-2.

- j. Low primary line voltage. See paragraph 3-3.
- k. Incorrect primary line connections. See paragraph 3-3.

A wire feed speed lower than 7 inches per 10 seconds is not, in itself, cause for concern. If everything appears to be running free and the primary voltage is not excessively low, then a minimum speed of less than 7 inches per minute might be quite normal. To double check place the heat control plug into the No. 6 receptacle. Turn the WIRE FEED SPEED FINE ADJUSTMENT to MAX. Run out wire for a timed 10 second interval and measure the wire. The total length of wire should be in excess of 65 inches. If not, recheck the drive system as before.

While it is always best to calibrate the machine in accordance with the preceding instructions, a rule of thumb can be employed when a timing device is not available or to make adjustment initially prior to actual feed measurement. To do this, place the heat control plug into the No. 1 receptacle. Turn the WIRE SPEED FINE ADJUSTMENT to MIN. To prevent the wire from being energized, remove the red jack plug from its receptacle and allow it to hang free. Run wire out of the gun and at the same time gradually increase the spindle tension by turning the tension adjustment nut on the hub support shaft in a clockwise direction. When the motor starts to slow excessively, bog or otherwise operate erratically, stop feeding wire. Now back off the tension adjustment nut approximately two turns counterclockwise. The wire should now feed between 7 and 13 inches of wire in a ten second period.

5-2. MONOCOIL

A. Removal of Monocoil (Figure 5-1)

1. Remove the welding wire from the wire drive assembly and gun.
2. Loosen set screw (item 2, Figure 5-1) in the gun handle.
3. Pull off nozzle (5).
4. Remove gun connector (4) by rotating it counterclockwise.
5. By coiling the gun cable, expose the monocoil liner (3) out of the end of the gun.
6. Loosen securing screw (1) on drive assembly.
7. Grip the monocoil liner (3) with a pliers.
8. Straighten out the gun cable and apply a firm steady pull on the liner (3) while shaking the gun cable vigorously.

IMPORTANT

Do not pull or bend the monocoil liner (3) too abruptly as this may result in damage to the liner.

B. Cleaning the Monocoil Assembly

Occasional cleaning of the monocoil liner is recommended to help ensure optimum performance. The frequency that cleaning is necessary is dependent upon the amount the machine is used, the cleanliness of the wire and the flakiness of the wire.

To clean the monocoil liner remove as directed above. Wash in a thinner or dry cleaning solvent that is non-corrosive, non-toxic, and one that will evaporate without residue. There are several trade name products on the market that are recommended for this purpose. Dry and reinstall as directed below.

C. Inserting Monocoil Assembly (Figure 5-1)

1. Place gun cable straight out.
2. Insert monocoil assembly (3) into the gun.

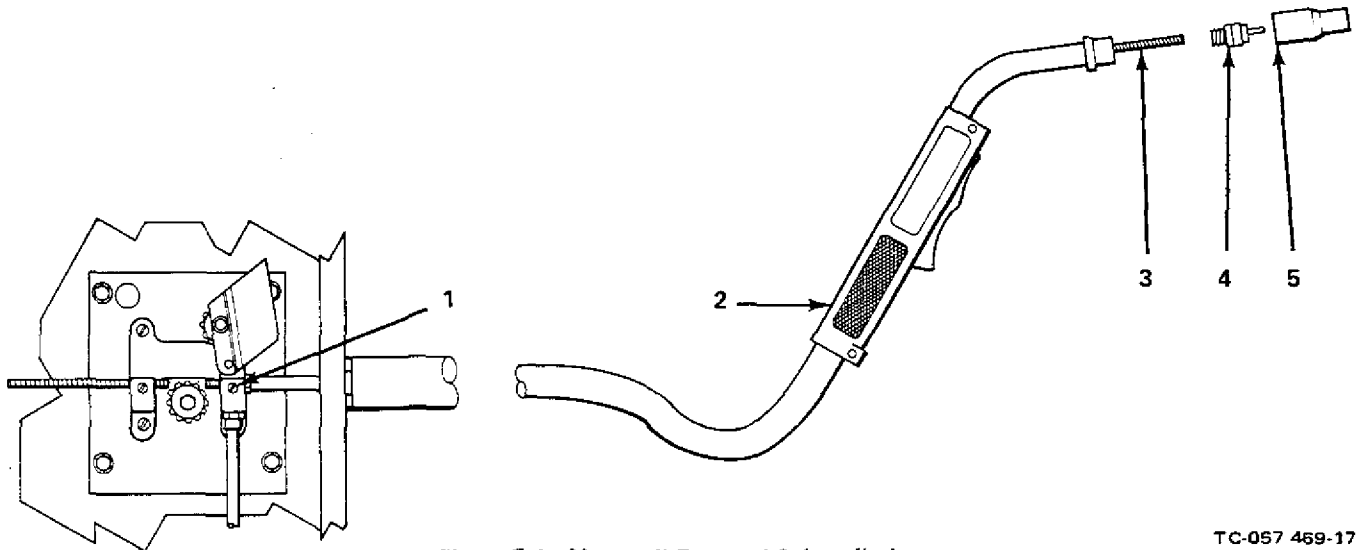

Figure 5-1. Monocoil Removal & Installation

TC-057 469-17

3. Feed monocoil assembly (3) into gun cable until it reaches the assembly connector on the drive assembly

NOTE

An occasional shake of the gun cable will help to ensure smooth installation of the monocoil assembly.

4. If the monocoil liner should become caught on the liner connector on the drive assembly a vigorous shaking of the gun cable should free the liner.
5. By coiling the gun cable a backward force will be placed on the liner thus helping to push the monocoil into the drive assembly.
6. When the monocoil pushes up to the drive gears, position it so it will just clear both the lower and upper gear when the upper portion is in position to feed wire.
7. Tighten securing screw (1) on the drive assembly.
8. Bend the gun cable until a portion of the monocoil is exposed out of the gun head tube. Place gun connector (4) onto exposed end of monocoil and rotate in gun head tube in a clockwise direction.
9. Tighten set screw (2) in gun holder.
10. Push nozzle (5) back onto the gun.

5-3. REMOVAL OF DRIVE ROLL GEARS (Figure 5-2)

A. Removal of Upper Drive Roll Gear

1. Grasp tension spring (item 10, Figure 5-2) at the top and pull tension spring (10) outward until it disengages from cover (6).
2. Remove pin (17) from the back side of shaft (18).
3. Pull out shaft (18) from drive roll cover (6) and lift off drive roll cover (6).
4. Pull off snap rings (1 & 8) from shaft (5).
5. Pull out bearing (2) from drive roll cover (6).
6. Slide shaft (5) out of drive roll cover (6) until drive roll gear (3) drops out.
7. Ensure that key (4) remains in the slot in shaft (5).

B. Removal of Lower Drive Roll Gear

1. Remove nut (11) from drive shaft (15).

2. Slide drive roll gear (12) off of drive shaft (15).
3. Ensure that key (14) remains in the slot in drive shaft (15).

5-4. INSTALLATION OF DRIVE ROLL GEARS (Figure 5-2)

A. Installation of Upper Drive Roll Gear

1. Place drive roll gear (3) inside of cover (6) ensuring that the tooth side of drive roll gear (3) is toward the back side of cover (6).
2. Align key (4) in shaft (5) with keyway in drive roll gear (3) and slide shaft (5) through drive roll gear (3) and cover (6).
3. Install bearing (2) into cover (6).
4. Install snap rings (1 & 8) back onto front and rear ends of shaft (5).
5. Place cover (6) onto drive assembly base (9) and align the holes in cover (6) with the hole in drive assembly base (9).
6. Insert shaft (18) through cover (6) and drive assembly base (9) until the groove in shaft (18) is exposed out of the back side of drive assembly base (9).
7. Insert Pin (17) onto groove in shaft (18).

B. Installation of Lower Drive Roll Gear

1. Align the keyway in drive roll gear (12) with the key (14) in drive shaft (15) and slide drive roll gear (12) onto drive shaft (15) until it seats against spring washer (13).
2. Rotate nut (11) onto drive shaft (15) in a clockwise direction until it makes contact with drive roll gear (12).
3. Install a spool of wire in the welding power source and thread the wire through inlet liner and partially into the gun monocoil.
4. Rotate nut (11) until the groove in drive roll gear (12) is centered under the wire.

5-5. CIRCUIT BREAKERS

Two circuit breakers, located immediately above the drive roll assembly, are provided to protect the welding power source in the event an overload should occur. Should either of these circuit breakers trip, the welding power source would become inoperative. These circuit breakers must be manually depressed in order to reset.

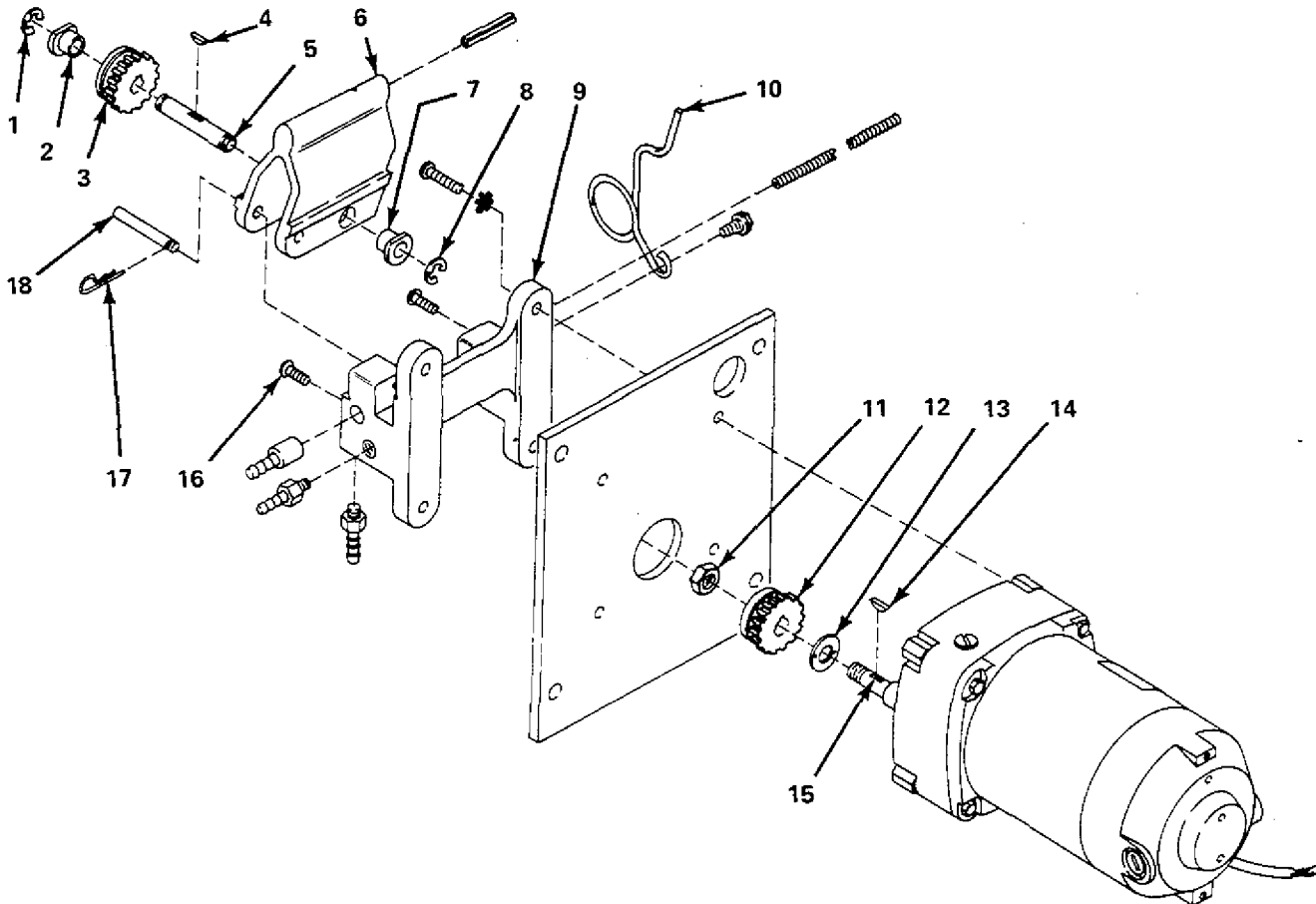

Figure 5-2. Drive Roll Gear Removal & Installation

TC-058 365

SECTION 6 - TROUBLESHOOTING

The data collected here, discusses some of the common problems which may occur in this welding power source. A little thought will probably solve the problem involved through the information provided.

The assumption of this data is that a proper welding condition has been achieved and has been used until trouble developed. In all cases of equipment malfunction, the manufacturer's recommendations should be strictly adhered to and followed.

If after performing the following procedures the trouble is still not remedied, it is recommended that a servicperson be called.

It is recommended that the circuit diagram be used for reference during the troubleshooting.

NOTE

Until further note, the following troubles apply to welding power sources without spot panel and welding power sources with spot panel that the Process Selector switch is in the CONTINUOUS WELDING position.

| TROUBLE | PROBABLE CAUSE | REMEDY |
|---|--|---|
| Low output fan motor (FM) runs slow. | Primary jumper link in wrong position. | Place jumper link in position for primary voltage being used. See Section 3-3 figure 3-5. |
| | Low primary voltage. | Connect machine to proper primary input voltage. |
| Output normal, fan motor (FM) does not run. | Fan motor (FM) defective. | Replace fan motor (FM). |
| | Loose connections to fan motor (FM). | Tighten connections to fan motor (FM). |
| No output, fan motor (FM) does not run. | POWER switch (S1) defective. | Replace power switch (S1). |
| | Primary fuses blown. | Replace primary fuses. |

| TROUBLE | PROBABLE CAUSE | REMEDY |
|---|---|--|
| No output, fan motor (FM) does not run. | Line fuse open. | Check and replace line fuses if necessary. |
| | Loose primary connections. | Check tightness of all primary connections. |
| | Primary disconnect switch (S1) open. | Place switch (S1) in closed position. |
| | Line circuit breaker tripped. | Reset line circuit breaker. |
| No open circuit voltage, fan motor (FM) runs and wire does feed. | Defective diode in main rectifier (SR1). | Check diodes (D1) through (D4) for continuity, should conduct in one direction and not in other. If bad, replace. |
| | Loose connection in main rectifier (SR1) or secondary terminals. | Secure connections in (SR1). |
| No open circuit voltage, fan motor (FM) runs and wire does not feed. | Gun switch (S3) defective. | Replace gun switch (S3). |
| | Contactator coil (W) defective. | Place contactor coil (W). |
| | Weld Current/Course Wire Feed Speed plug not secure in receptacle. | Secure plug by inserting into receptacle and turning it in a clockwise direction. |
| | Jumper link between terminals 2 and 3 or terminal strip (1T) not in proper place. (Models without spot panel only). | Install jumper link (1T). |
| | Plug from gun switch not secure in receptacle (RC1) in welding machine. | Secure plug in receptacle (RC1). If trouble still exists, check to ensure that leads are secure in both plug and receptacle. |
| | Transformer (T1) defective. | Replace transformer (T1). |
| Wire does not feed. Fan motor (FM) runs and open circuit voltage is normal. | Circuit Breaker (CB1 or CB2) tripped. | Reset circuit breaker (CB1 or CB2). |
| | Circuit Breaker (CB1 or CB2) defective. | Replace circuit breaker (CB1 or CB2). |
| | Jumper link between terminals 44 and 45 of terminal strip (1T) not in place. (Models without spot panel only). | Install jumper link. |
| | Wire Feed Fine Adjustment Control (R1) open. | Replace rheostat (R1). |
| | Rectifier (SR2) defective. | Replace rectifier (SR2). |
| | Wire feed motor (M) is defective. | Replace motor (M). |
| Wire does not feed when CONTINUOUS/SPOT switch (S2) is in Spot position. Open Circuit voltage normal. | Thyristor (Q52) is shorted. | Replace thyristor (Q52). |
| | Circuit Breaker (CB1 or CB2) tripped. | Reset circuit breaker (CB1 or CB2). |
| | Circuit Breaker (CB1 or CB2) defective. | Replace circuit breaker (CB1 or CB2). |
| | Wire Feed Fine Adjustment Control (R1) open. | Replace rheostat (R1). |
| | Rectifier (SR2) defective. | Replace rectifier (SR2). |
| | Wire feed motor (M) is defective. | Replace motor (M). |

NOTE

The following troubles apply to models with spot panel only.

| TROUBLE | PROBABLE CAUSE | REMEDY |
|---|---|--|
| Wire does not feed, no open circuit voltage and fan motor (FM) does run CONTINUOUS/ SPOT switch in SPOT position. | Thyristor (Q51) shorted. | Replace thyristor (Q51). |
| | Defective diode in rectifier in spot panel. | Check diodes (D51) through (D54) for continuity, should conduct in one direction and not in other. If bad, replace. |
| | Resistor (R53) open. | Replace resistor (R53). |
| | Relay (CR51) defective. | Replace relay (CR51). |
| | Gun switch (S3) defective. | Replace gun switch (S3). |
| | Weld Current/Coarse Wire Feed Speed plug not secure in receptacle. | Secure plug clockwise direction. |
| | Plug from gun switch not secure in receptacle (RC1) in welding machine. | Secure plug in receptacle (RC1). If trouble still exists, check to ensure that leads are secure in both plug and receptacle (RC1). |
| | Contactor coil (W) defective. | Replace contactor coil (W). |
| | Transformer (T1) defective. | Replace transformer (T1). |
| Spot Weld Timer and Spot Burnback Timer inoperative. Wire feed continuously. Output normal. | Diode (D55) shorted. | Replace diode (D55). |
| | Resistor (R56) open. | Replace resistor (R56). |

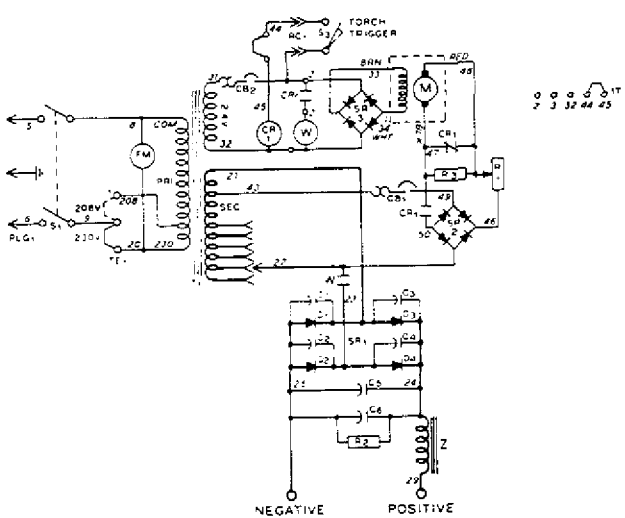

Circuit Diagram
No. CA-057 436-1B1

Figure 6-1. Circuit Diagram For Model Without Spot Panel

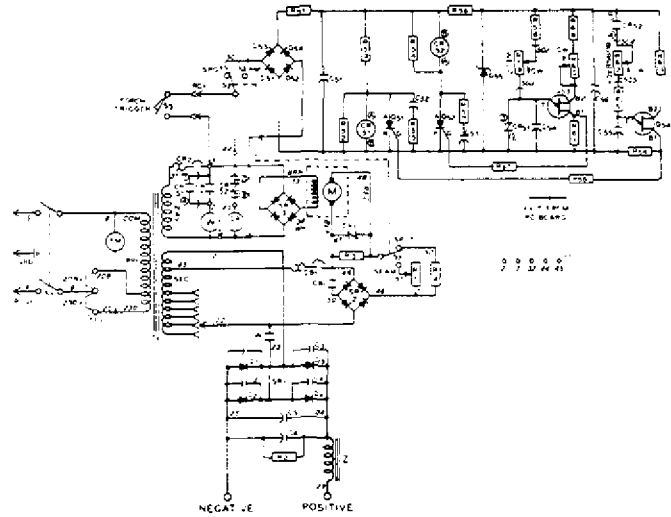

Circuit Diagram No.
CB-057 469-1G2

Figure 6-2. Circuit Diagram For Model With Spot Panel

April 1976

FORM: OM-1301B

Effective with serial No. HF876062

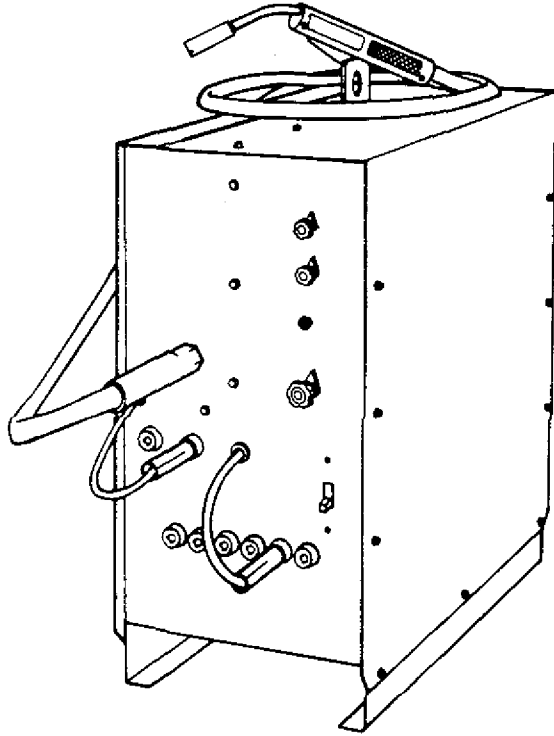

| MODEL/STOCK NO. | SERIAL/STYLE NO. | DATE PURCHASED |
|-----------------|------------------|----------------|
| | | |

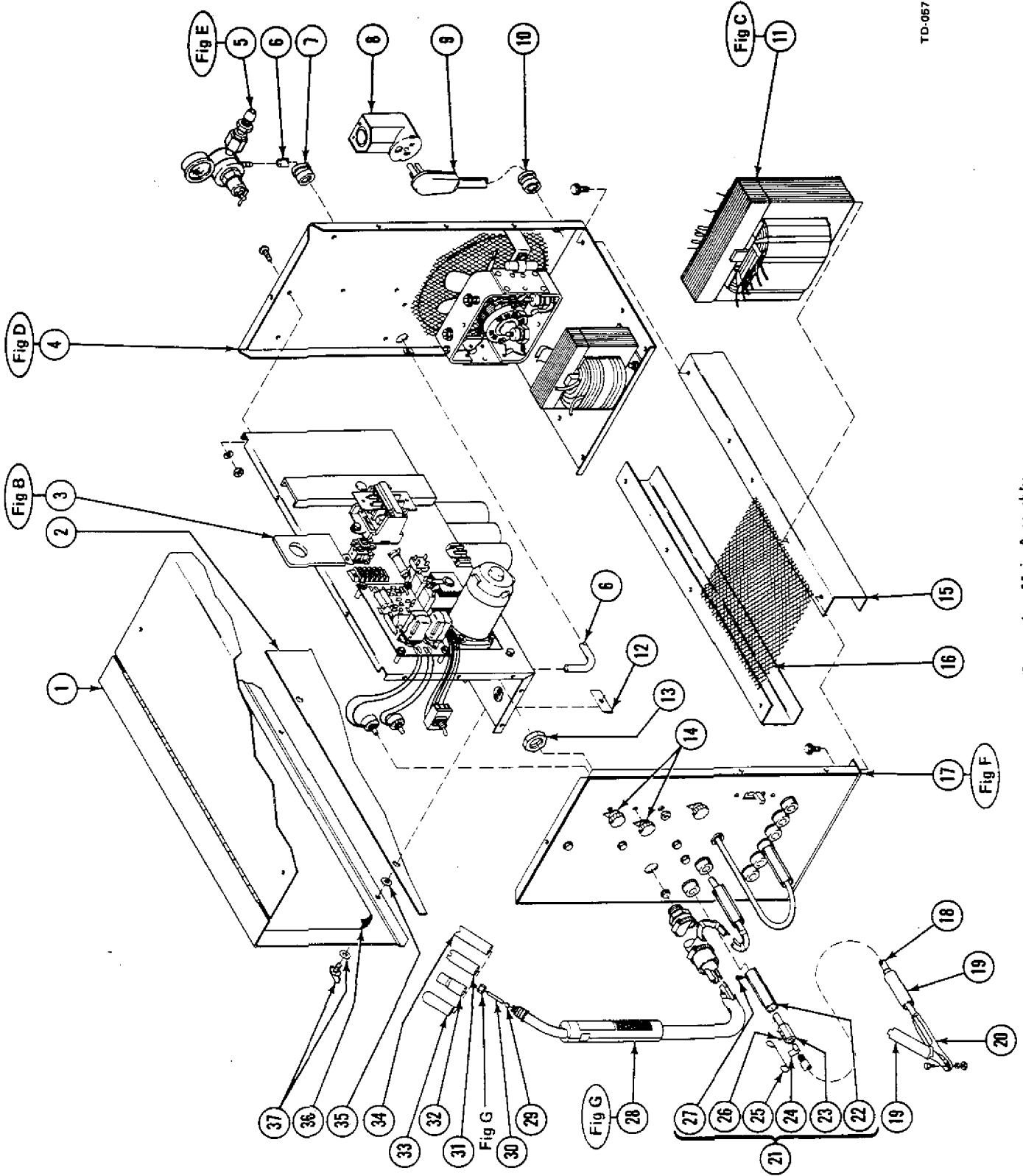

Figure A - Main Assembly

| Item No. | Dia. Mkgs. | Factory Part No. | Description | Quantity Model | |
|-------------------------------|------------|------------------|--|--------------------|-----------------|
| | | | | Without Spot Timer | With Spot Timer |
| Figure A Main Assembly | | | | | |
| 1 | | 057 498 | WRAPPER | 1 | 1 |
| 2 | | 057 506 | PANEL, side | 1 | 1 |
| 3 | | Figure B | BAFFLE, air - with components (See Page 4) | 1 | 1 |
| 4 | | Figure D | PANEL, rear - with components (See Page 8) | 1 | 1 |
| 5 | | 057 755 | KIT, gas control (See Fig. E Page 9) | 1 | 1 |
| 6 | | 023 081 | HOSE, rubber 1/4 x 1 x 8 ft. long | 1 | 1 |
| 7 | | 010 325 | BUSHING, strain relief | 1 | 1 |
| 8 | PLG1 | 039 778 | RECEPTACLE, straight 3 pole 50 ampere 250 volt | 1 | 1 |
| 9 | | 023 210 | CORD, power 10/3 9 ft. long | 1 | 1 |
| 10 | | 010 290 | BUSHING, strain relief | 1 | 1 |
| 11 | T1 | 023 012 | TRANSFORMER, power - main (See Fig. C Page 7) | 1 | 1 |
| 12 | | 010 357 | RECEPTACLE, clip on | 2 | 2 |
| 13 | | 605 227 | NUT, galv, hex 3/4 | 2 | 2 |
| 14 | | 024 366 | KNOB, pointer | | 2 |
| 15 | | 057 531 | SKID, base | 2 | 2 |
| 16 | | 024 301 | METAL, expanded | 1 | 1 |
| 17 | | Figure F | PANEL, front - with components (See Page 10) | 1 | 1 |
| 18 | | 023 100 | CABLE, ground No. 4 10 ft. long | 1 | 1 |
| 19 | | 026 843 | INSULATOR, vinyl - black | 2 | 2 |
| 20 | | 025 190 | CLAMP | 1 | 1 |
| 21 | | 039 901 | PLUG ASSEMBLY, jack - black (consisting of) | 1 | 1 |
| 22 | | 026 978 | INSULATOR, jack plug - black | 1 | 1 |
| 23 | | 101 219 | PLUG, jack | 1 | 1 |
| 24 | | 019 833 | STRIP, copper | 1 | 1 |
| 25 | | 010 521 | WIRE, tie | 1 | 1 |
| 26 | | 602 178 | SCREW, set 1/4-20 x 3/8 | 2 | 1 |
| 27 | | 602 160 | SCREW, self tapping 8-32 x 1/4 | 1 | 1 |
| 28 | | 058 260 | GUN (See Fig. G Page 11) | 1 | 1 |
| 29 | | 057 591 | SLEEVE, brass - compression 3/16 TBG | 6 | 6 |
| 30 | | *057 559 | TUBE, contact .030 wire | 3 | 3 |
| 30 | | *057 560 | TUBE, contact .035 wire | 3 | 3 |
| 31 | | 058 375 | NOZZLE, spot - slip type | | 1 |
| 32 | | 058 369 | NOZZLE, slip type 2 long | 2 | 2 |
| 33 | | 058 372 | NOZZLE, spot - slip type inside corner | | 1 |
| 34 | | 058 374 | NOZZLE, spot - slip type out side corner | | 1 |
| 35 | | 010 855 | RETAINER, screw No. 2 | 2 | 2 |
| 36 | | 031 881 | LABEL, instructions | 1 | 1 |
| 37 | | 605 217 | FASTENER, wing head No. 2 screw | 2 | 2 |
| | | 057 745 | SPRING, compression - wire spool | 1 | 1 |
| Optional Equipment | | | | | |
| | | 058 370 | NOZZLE, slip type - blank 2-3/8 | 1 | 1 |
| | | 058 371 | NOZZLE, slip type - blank 4 | 1 | 1 |
| | | 058 373 | NOZZLE, slip type - inside corner | 1 | 1 |
| | | 058 379 | NOZZLE, slip type 1/2 orifice | 1 | 1 |

*Recommended Spare Parts.

BE SURE TO PROVIDE STOCK, MODEL, AND SERIAL NUMBERS WHEN ORDERING REPLACEMENT PARTS.

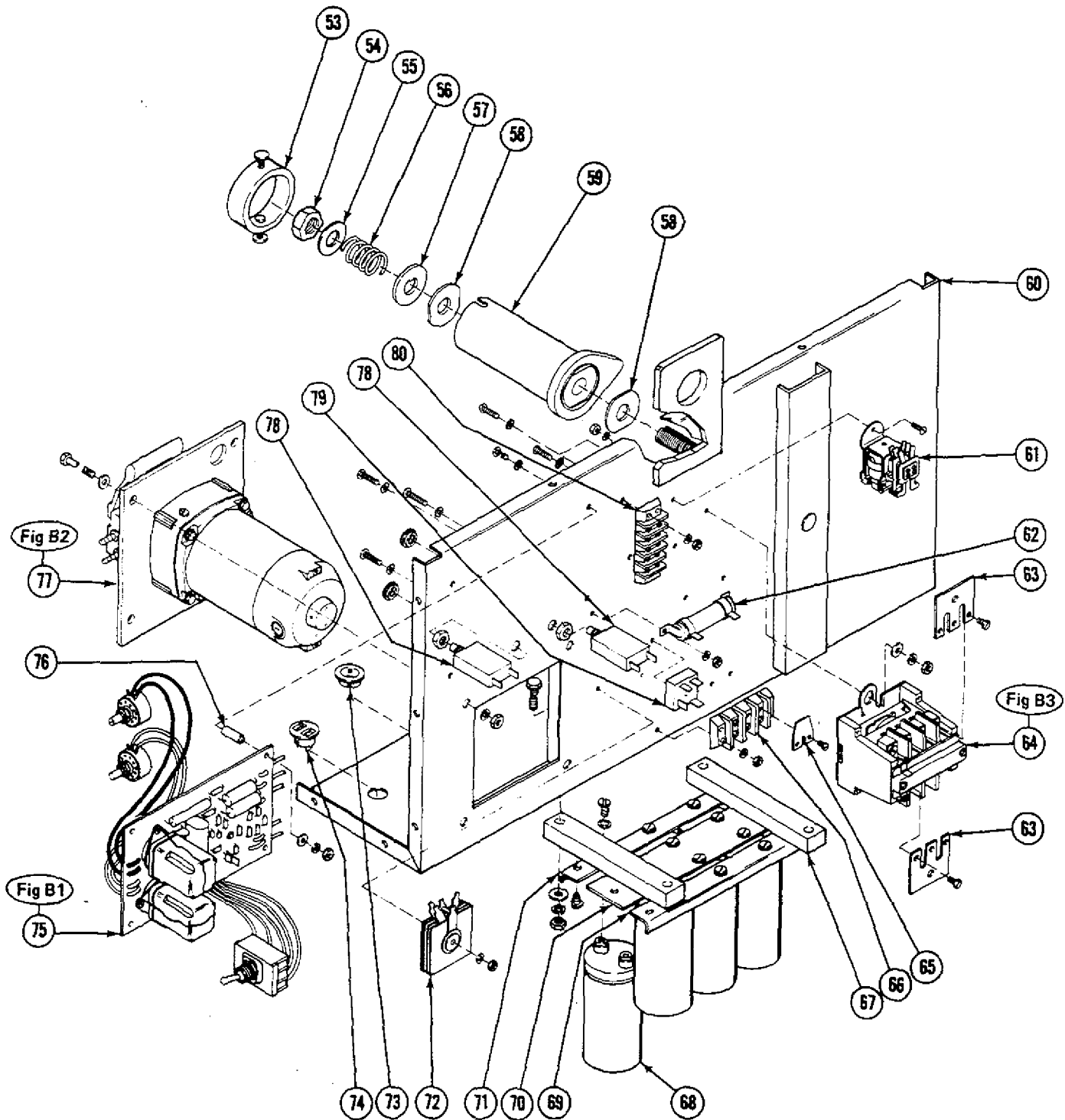

Figure B – Baffle, Air With Components

TD-001 826-C

| Item No. | Dia. Mkgs. | Factory Part No. | Description | Quantity | |
|-----------------|------------|------------------|---|---|-----------------|
| | | | | Without Spot Timer | With Spot Timer |
| Figure B | | | | Baffle, Air With Components (See Fig. A Page 2 Item 3) | |
| 53 | | 058 427 | RING, retaining - spool | 1 | 1 |
| 54 | | 601 884 | NUT, steel - hex jam 5/8-11 | 1 | 1 |
| 55 | | 605 941 | WASHER, flat - steel 1 inch | 1 | 1 |
| 56 | | 057 543 | SPRING, compression | 1 | 1 |
| 57 | | 057 971 | WASHER, flat - steel keyed 1-1/2 inch | 1 | 1 |
| 58 | | 058 424 | WASHER, fiber - brake | 2 | 2 |
| 59 | | 058 428 | HUB, spool | 1 | 1 |
| 60 | | 031 412 | BAFFLE, air | 1 | 1 |
| 61 | CR1 | 034 841 | RELAY, 24 volt ac DPDT | 1 | 1 |
| | | 026 837 | INSULATOR, terminal - nylon | 4 | 4 |
| 62 | R3 | 030 651 | RESISTOR, WW fixed 25 watt 10 ohm | 1 | 1 |
| 63 | | 057 511 | LINK, connecting - contactor (Cutler Hammer) | 2 | 2 |
| 63 | | 034 260 | LINK, connecting - contactor (Furnas) | 2 | 2 |
| 64 | W | 034 883 | CONTACTOR, 40 amp 3 pole 24 volt (Cutler Hammer) or | | |
| 64 | W | 035 519 | CONTACTOR, 40 amp 3 pole 24 volt (Furnas)(See Fig. B3 Page 7) | 1 | 1 |
| 65 | | 038 620 | LINK, jumper - terminal block 30 amp | 1 | 1 |
| 66 | TE1 | 026 189 | BLOCK, terminal 30 amp 3 pole | 1 | 1 |
| 67 | | 057 510 | INSULATOR, mtg - capacitor | 2 | 2 |
| | | 026 631 | INSULATION (placed between flat washer and item 67) | 4 | 4 |
| 68 | C6 | 031 728 | CAPACITOR, electrolytic 9000 uf 35 volt dc | 6 | 6 |
| 69 | | 027 485 | ANGLE, mtg - left hand capacitor | 1 | 1 |
| 70 | | 027 486 | STRIP, mtg - center capacitor | 1 | 1 |
| 71 | | 027 484 | ANGLE, mtg - right hand capacitor | 1 | 1 |
| 72 | SR3 | 037 727 | RECTIFIER, selenium 33 volt 1.2 amp | 1 | 1 |
| 73 | | 010 493 | BUSHING, snap 5/8 ID x 7/8 hole | 1 | 1 |
| 74 | RC1 | 022 070 | BUSHING, nylon - terminal double 1/4 male | 1 | 1 |
| 75 | | 058 695 | CIRCUIT CARD ASSEMBLY, with switch (See Fig. B1 Page 5) | | 1 |
| 76 | | 010 486 | TUBING, steel 5/8 inch long | 4 | 4 |
| 77 | | 058 365 | DRIVE ASSEMBLY, wire (See Fig. B2 Page 6) | 1 | 1 |
| 78 | CB1,2 | *011 243 | CIRCUIT BREAKER, 5 amp | 2 | 2 |
| 79 | SR2 | 037 346 | RECTIFIER, integrater 6.5 amp 400 volt | 1 | 1 |
| 80 | 1T | 038 839 | BLOCK, terminal 20 amp 5 pole | 1 | 1 |
| | | 601 219 | LINK, jumper | 2 | |

*Recommended Spare Parts.

BE SURE TO PROVIDE STOCK, MODEL, AND SERIAL NUMBERS WHEN ORDERING REPLACEMENT PARTS.

CERTAIN NON CRITICAL PARTS LISTED BELOW MAY DIFFER FROM THOSE USED ON THE CIRCUIT CARD IN YOUR UNIT, BUT WILL SERVE AS SUITABLE REPLACEMENTS.

| Dia. Mkgs. | Factory Part No. | Description | Quantity |
|------------|------------------|---|----------|
| Figure B1 | 058 695 | Circuit Card Assembly, With Switch | |
| S2 | 011 611 | SWITCH, toggle DPDT 15 amp 125 volt | 1 |
| | **027 248 | CIRCUIT CARD ASSEMBLY (consisting of) | 1 |
| C51,56 | 031 633 | CAPACITOR, electrolytic 80 uf 25 volt dc | 2 |
| C52,53 | 031 643 | CAPACITOR, ceramic 0.01 uf 500 volt dc | 2 |
| C54,55 | 032 943 | CAPACITOR, tantalum 4.7 uf 35 volt dc | 2 |
| CR51 | 032 944 | RELAY, 12 volt dc DPDT | 1 |
| CR52 | 032 945 | RELAY, 24 volt dc DPDT | 1 |
| | 032 946 | SOCKET, relay | 2 |
| D51-54 | 026 202 | DIODE, 1 ampere 400 volt straight polarity | 4 |
| D55 | 037 243 | DIODE, zener 18 volt 1 watt | 1 |
| Q51,52 | 022 135 | THYRISTOR, 4 amp 200 volt | 2 |
| Q53,54 | 037 289 | TRANSISTOR, unijunction 50MA 35 volt | 2 |
| R51 | 030 055 | RESISTOR, carbon 2 watt 10 ohm | 1 |
| R52,54,65 | 030 024 | RESISTOR, carbon 0.5 watt 1000 ohm | 3 |
| R53 | 030 630 | RESISTOR, WW fixed 11 watt 100 ohm | 1 |
| R55,57 | 030 937 | RESISTOR, carbon 0.5 watt 10 ohm | 2 |
| R56 | 030 709 | RESISTOR, carbon 1 watt 150 ohm | 1 |
| R58 | 030 004 | RESISTOR, carbon 0.5 watt 10K ohm | 1 |
| R59 | 030 738 | POTENTIOMETER, carbon 1 turn 2 watt 500K ohm | 1 |
| R60 | 030 145 | POTENTIOMETER, carbon 1 turn 0.25 watt 2000 ohm | 1 |
| R61,64 | 030 025 | RESISTOR, carbon 0.5 watt 100 ohm | 2 |
| R62 | 030 131 | POTENTIOMETER, carbon 1 turn 2 watt 50K ohm | 1 |
| R63 | 030 853 | RESISTOR, carbon 0.5 watt 2200 ohm | 1 |
| R66 | 030 024 | RESISTOR, carbon 0.5 watt 1000 ohm | 1 |
| R67,68 | 030 025 | RESISTOR, carbon 0.5 watt 100 ohm | 2 |

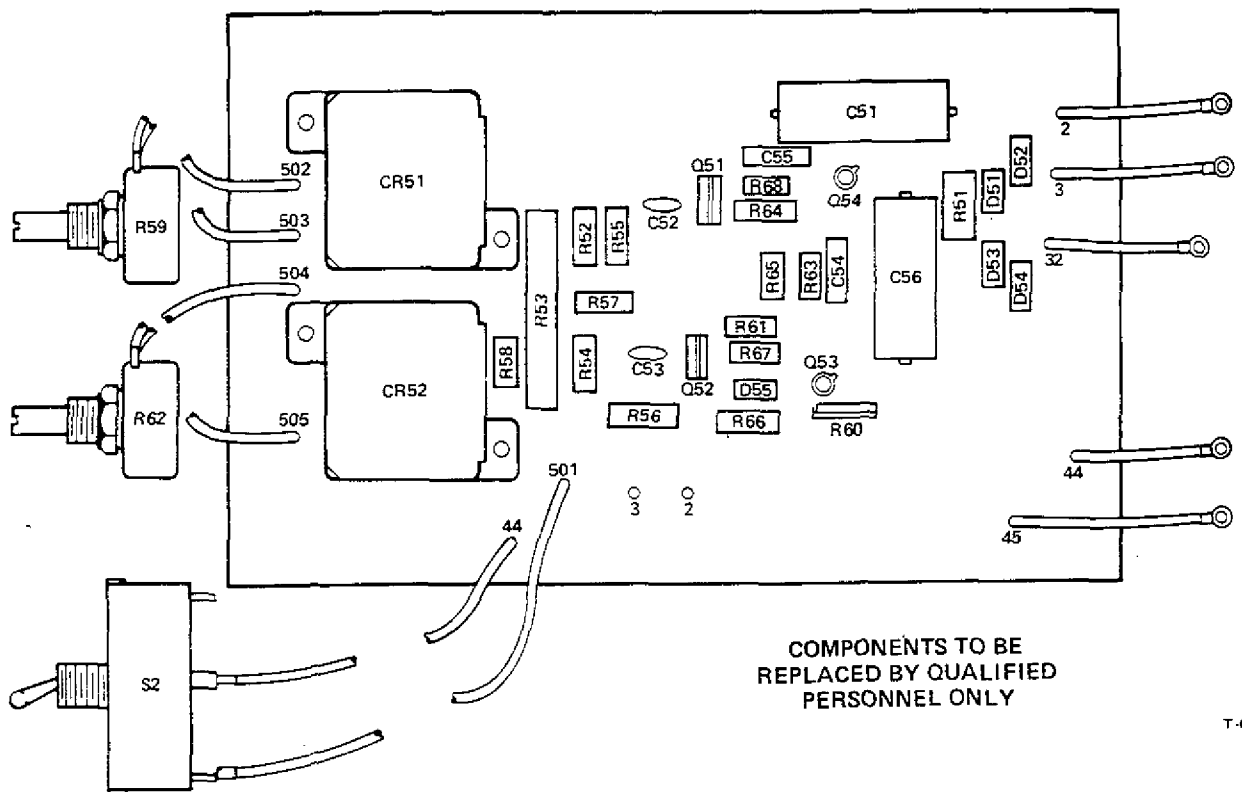
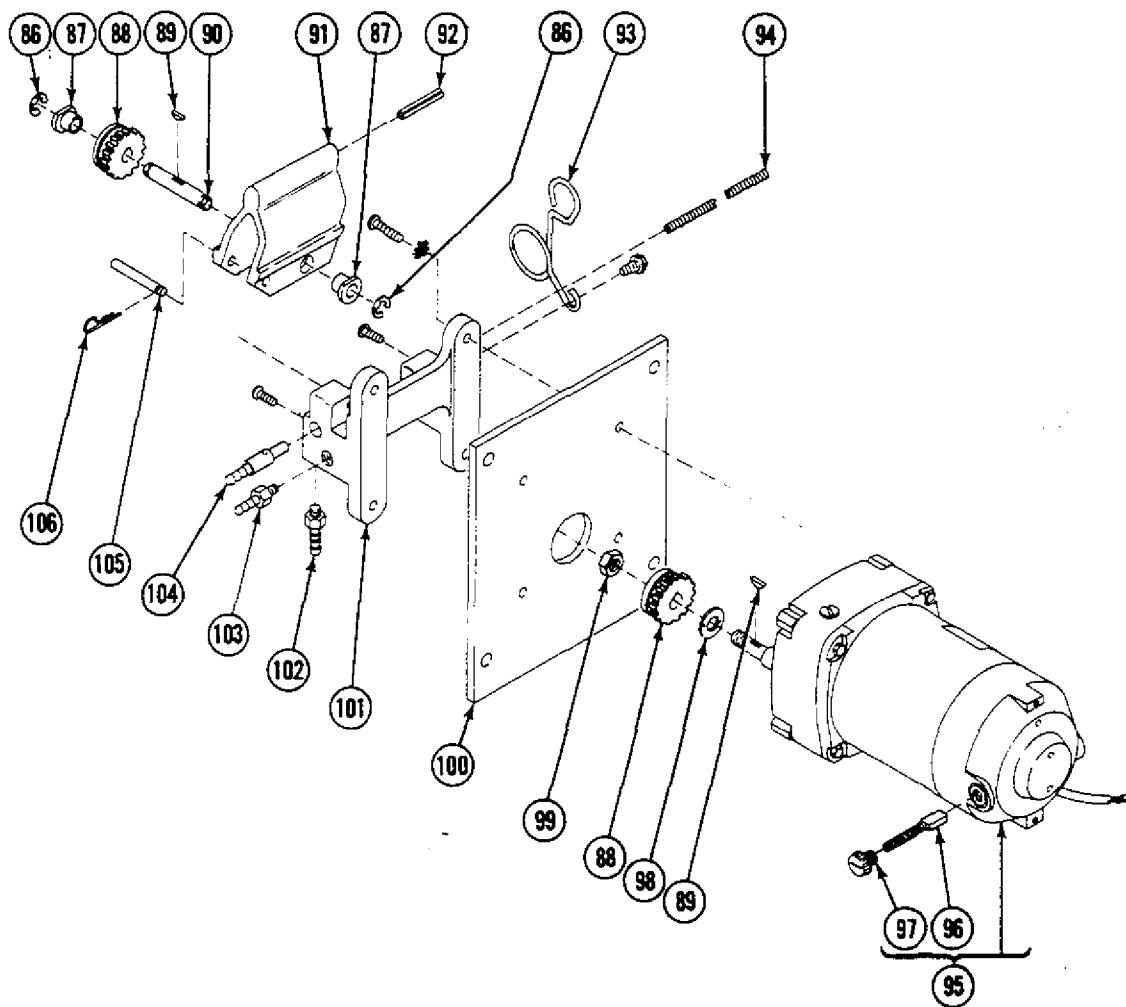

Figure B1 – Circuit Card Assembly, With Switch

**Circuit Card Assembly is available on an exchange basis. Contact Factory Service Department for details.
BE SURE TO PROVIDE STOCK, MODEL, AND SERIAL NUMBERS WHEN ORDERING REPLACEMENT PARTS.

| Item No. | Dia. Mkgs. | Factory Part No. | Description | Quantity |
|-----------|------------|------------------|--|----------|
| Figure B2 | 058 365 | | Drive Assembly, Wire (See Fig. B Page 4 Item 76) | |
| 86 | | 605 854 | RING, retainer | 2 |
| 87 | | 058 361 | BEARING, bronze | 2 |
| 88 | | 057 590 | GEAR, spur 20 tooth | 2 |
| 89 | | 605 287 | KEY, 1/16 x 1/4 | 2 |
| 90 | | 058 360 | SHAFT | 1 |
| 91 | | 058 363 | COVER | 1 |
| 92 | | 010 918 | PIN, spring 5/32 x 1-1/2 | 1 |
| 93 | | 057 551 | SPRING, pressure | 1 |
| 94 | | 056 081 | CONDUIT, stub liner | 1 |
| 95 | M | 605 824 | MOTOR, gear (consisting of) | 1 |
| 96 | | *031 595 | BRUSH, with spring | 2 |
| 97 | | 057 432 | SCREW, brush holder cap | 2 |
| 98 | | 010 929 | WASHER, flat - spring 3/8 | 1 |
| 99 | | 605 525 | NUT, steel - self locking hex 5/16-24 | 1 |
| 100 | | 058 362 | MOUNTING PAD, motor | 1 |
| 101 | | 058 364 | HOUSING | 1 |
| 102 | | 604 313 | COUPLING, brass - male 1/4 ID hose 1/4-18 thd | 1 |
| 103 | | 057 739 | COUPLING, male 1/8 MPT x 1/8 ID hose | 1 |
| 104 | | 058 268 | STEM, barbed | 1 |
| 105 | | 058 359 | PIN, pivot | 1 |
| 106 | | 604 741 | PIN, cotter - hair .042 x 15/16 | 1 |



TC-058 365

Figure B2 - Drive Assembly, Wire

*Recommended Spare Parts.

BE SURE TO PROVIDE STOCK, MODEL, AND SERIAL NUMBERS WHEN ORDERING REPLACEMENT PARTS.

| Item No. | Factory Part No. | Description | Quantity |
|------------------|------------------|--|----------|
| Figure B3 | | Contactor (See Fig. B Page 4 Item 64) | |
| 121 | 023 101 | COIL (Cutler Hammer) | 1 |
| 121 | 024 493 | COIL (Furnas) | 1 |
| 122 | *034 889 | KIT, contact points (Cutler Hammer) | 3 |
| 122 | *034 894 | KIT, contact points (Furnas) | 1 |

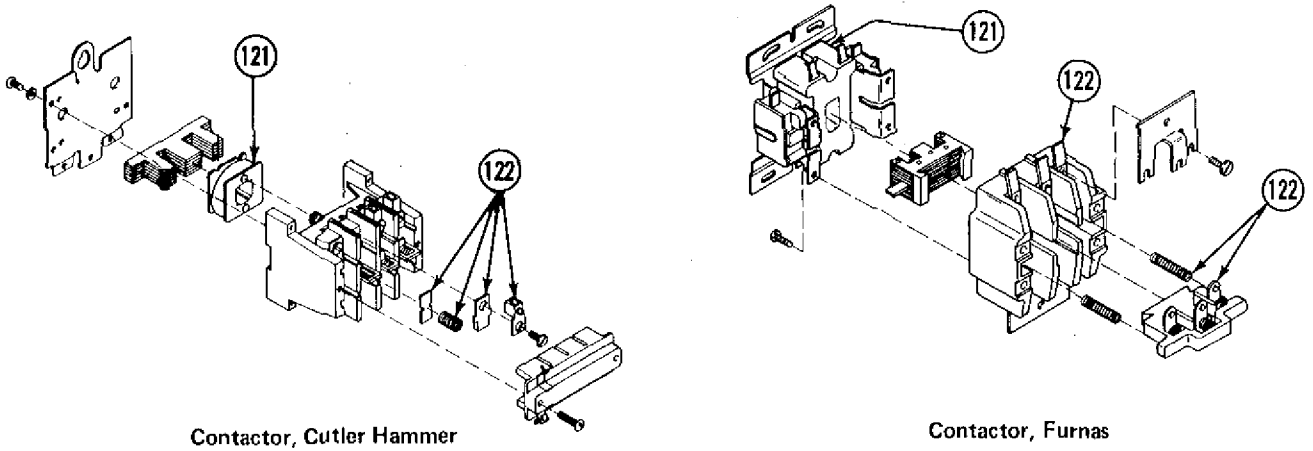

TB-034 883

TA-034 893

Figure B3 – Contactors

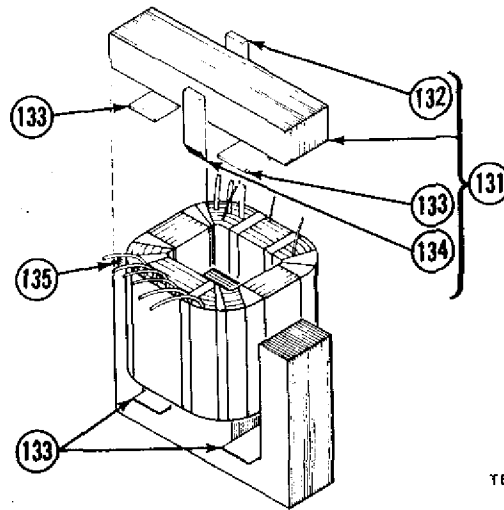

TB-023 012

Figure C – Transformer, Power

| Item No. | Factory Part No. | Description | Quantity |
|-----------------|------------------|---|----------|
| Figure C | 023 012 | Transformer, Power (See Fig. A Page 2 Item 11) | |
| 131 | 057 495 | TRANSFORMER SUBASSEMBLY (consisting of) | 1 |
| 132 | 022 393 | WEDGE, wood 3/8 x 1 x 6 | 1 |
| 133 | 023 442 | STRIP, glastic 1/16 x 1-11/16 x 3-3/4 | 4 |
| 134 | 026 967 | WEDGE, wood 5/16 x 1 x 6 | 1 |
| 135 | **057 536 | COIL, primary - secondary | 1 |

*Recommended Spare Parts.

**Replace At Factory or Authorized Service Station.

BE SURE TO PROVIDE STOCK, MODEL, AND SERIAL NUMBERS WHEN ORDERING REPLACEMENT PARTS.

| Item No. | Dia. Mkgs. | Factory Part No. | Description | Quantity |
|--|------------|------------------|--|----------|
| Figure D Panel, Rear With Components (See Fig. A Page 2 Item 4) | | | | |
| 146 | FM | 032 678 | MOTOR, fan 230 volt ac | 1 |
| 147 | | 032 662 | BLADE, fan 60 Hz 10 inch 6 wing | 1 |
| 148 | Z | 057 537 | STABILIZER | 1 |
| 149 | R2 | 030 886 | RESISTOR, WW adj 25 watt 50 ohm | 1 |
| 150 | | 057 493 | PANEL, rear | 1 |
| 151 | SR1 | 021 435 | RECTIFIER, main (consisting of) | 1 |
| 152 | | 057 496 | BRACKET, mtg - rectifier & fan motor | 1 |
| 153 | C5 | 031 683 | CAPACITOR, 0.5 uf 200 volt | 1 |
| 154 | | 010 014 | CLAMP, mtg - capacitor | 1 |
| 155 | | 037 306 | DIODE, 150 ampere 300 volt reverse polarity | 2 |
| 156 | C1-4 | 031 689 | CAPACITOR, with 3/16 x 1/4 terminals | 4 |
| 157 | | 037 305 | DIODE, 150 ampere 300 volt straight polarity | 2 |

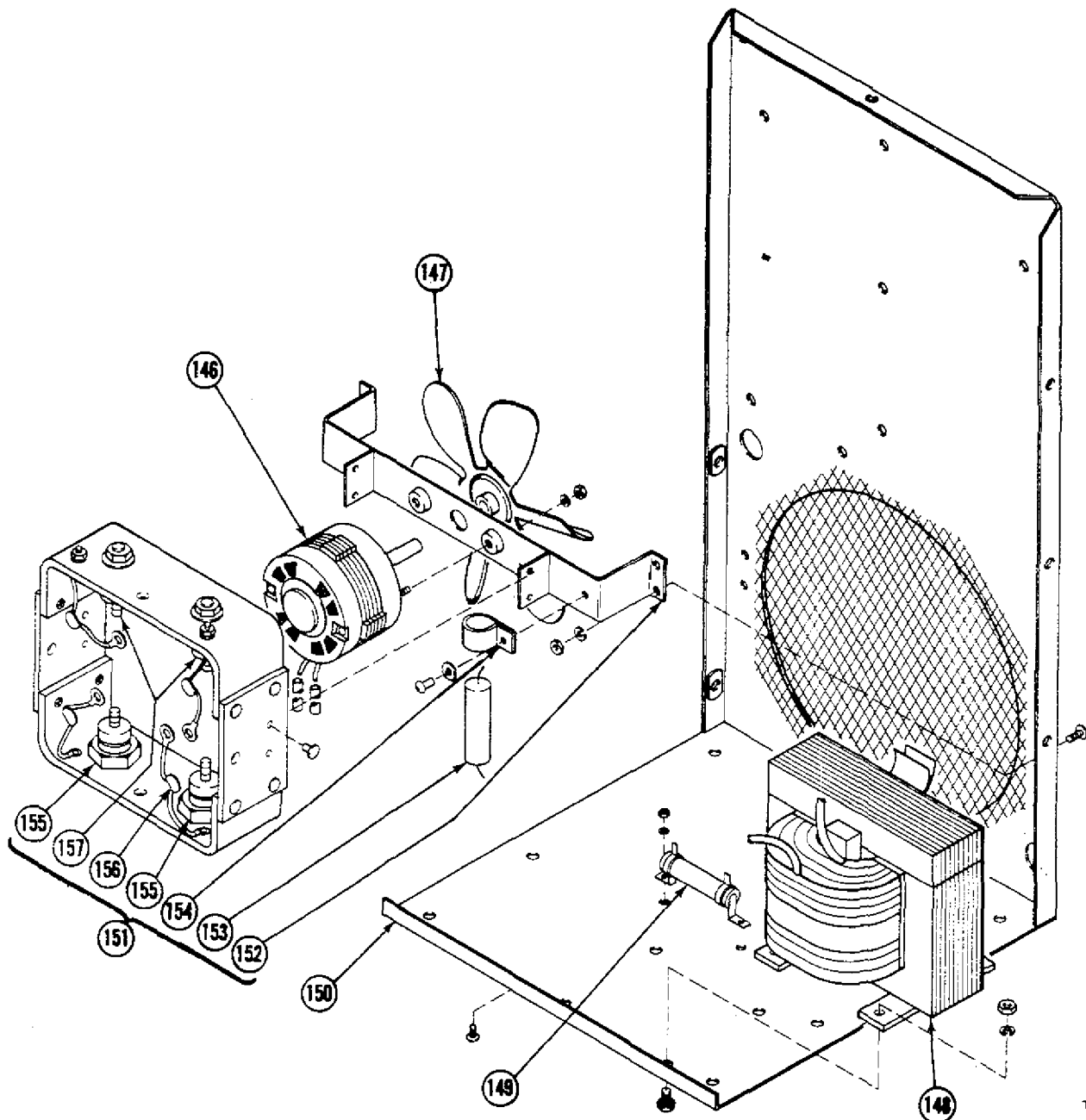

TD-023 011

Figure D - Panel, Rear with Components

BE SURE TO PROVIDE STOCK, MODEL, AND SERIAL NUMBERS WHEN ORDERING REPLACEMENT PARTS.

| Item No. | Factory Part No. | Description | Quantity |
|----------|------------------|---|----------|
| Figure E | 057 755 | Kit, Control - Gas (See Fig. A Page 2 Item 5) | |
| 166 | 003 253 | REGULATOR, Norgren 11-010 with blue housing (consisting of) | 1 |
| 167 | 602 958 | COUPLING, brass - male 1/4 ID hose 1/4 MPT | 1 |
| 168 | 605 288 | PLUG, galvanized pipe 1/4 MPT square hd | 1 |
| 169 | 057 545 | GAUGE, pressure 0-30 psi | 1 |
| 170 | 057 587 | WASHER, fiber | 1 |
| 171 | 057 546 | HANDLE, T | 1 |
| 172 | 057 581 | NUT, lock | 1 |
| 173 | 057 582 | SPRING, rest - upper | 1 |
| 174 | 057 583 | SPRING, regulating | 1 |
| 175 | 057 584 | SLIP RING, diaphragm | 1 |
| 176 | 057 585 | DIAPHRAGM ASSEMBLY | 1 |
| 177 | 057 586 | VALVE, with seal ring | 1 |
| 178 | 028 509 | ADAPTER, gas | 1 |

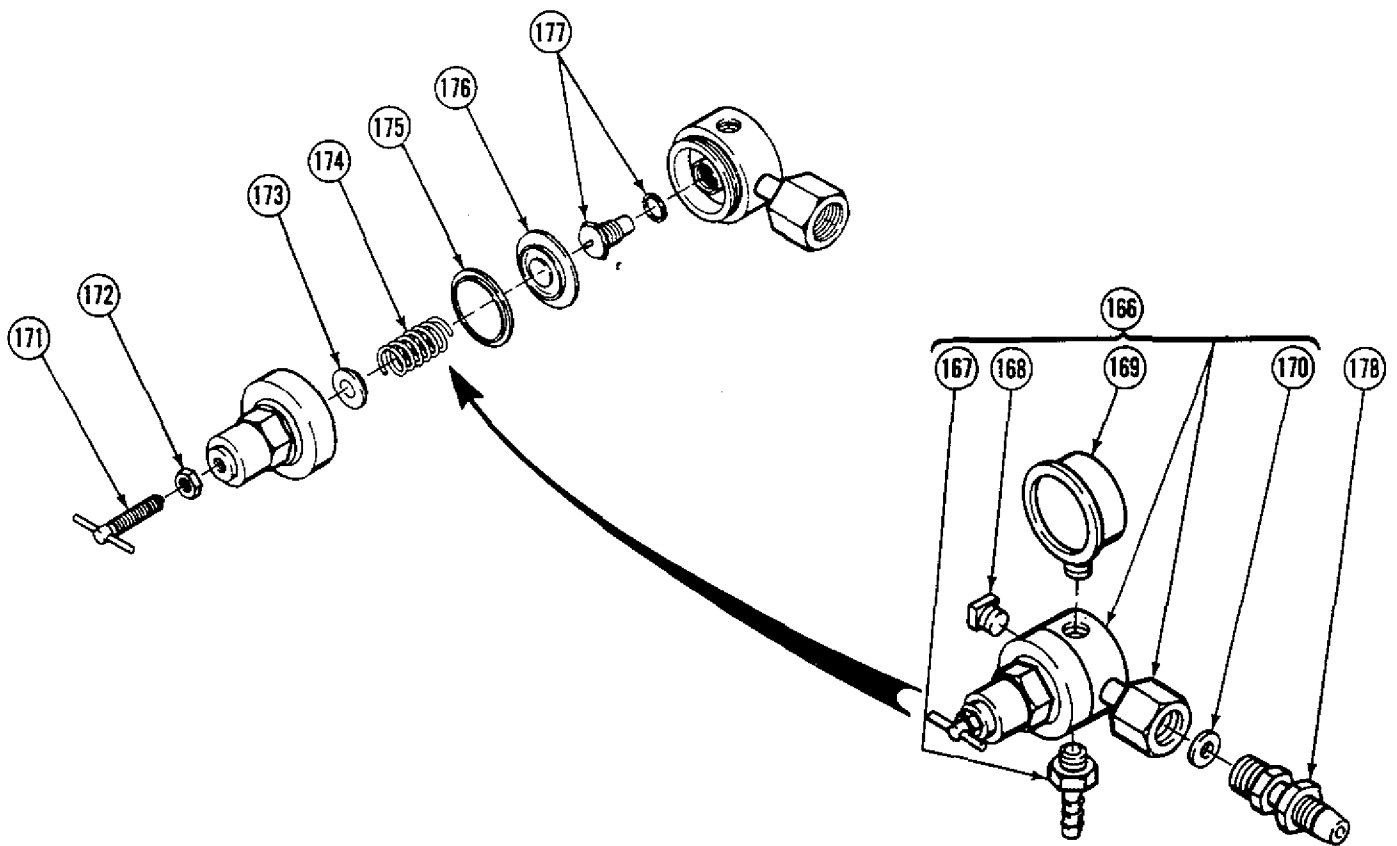

TA-028 728
TB-057 755

Figure E - Kit, Gas Control

BE SURE TO PROVIDE STOCK, MODEL, AND SERIAL NUMBERS WHEN ORDERING REPLACEMENT PARTS.

| Item No. | Dia. Mkgs. | Factory Part No. | Description | Quantity Model | |
|--|------------|------------------|--|--------------------|-----------------|
| | | | | Without Spot Timer | With Spot Timer |
| Figure F Panel, Front With Components (See Fig. A Page 2 Item 17) | | | | | |
| 200 | | 039 826 | RECEPTACLE ASSEMBLY, jack - black (consisting of) | 1 | 1 |
| 201 | | 039 796 | . NUT, terminal - black | 1 | 1 |
| 202 | | 010 291 | . WASHER, flat - nylafil 5/8 ID x 1-1/4 OD x 1/8 | 1 | 1 |
| 203 | | 604 668 | . NUT, steel - self locking hex 1/2-20 | 1 | 1 |
| 204 | | 020 015 | . RECEPTACLE | 1 | 1 |
| 205 | | 601 881 | . NUT, steel - hex jam 1/2-20 | 1 | 1 |
| 206 | | | NAMEPLATE (order by stock, model & serial numbers) | 1 | 1 |
| 207 | | 025 166 | PANEL, front | 1 | 1 |
| 208 | R1 | 605 828 | RHEOSTAT, WW 50 watt 1.5 ohm | 1 | 1 |
| 209 | R4 | 605 890 | RESISTOR, fixed 15 watt 0.25 ohm | 1 | 1 |
| 210 | | 019 609 | KNOB | 1 | 1 |
| 211 | | 026 190 | INSULATOR, switch | 1 | 1 |
| 212 | S1 | *011 629 | SWITCH, toggle DPST 30 ampere | 1 | 1 |
| 213 | | 010 325 | BUSHING, strain relief | 1 | 1 |
| 214 | | 057 608 | RECEPTACLE ASSEMBLY, jack - yellow (consisting of) | 6 | 6 |
| 215 | | 601 881 | . NUT, steel - hex jam 1/2-13 | 1 | 1 |
| 216 | | 020 015 | . RECEPTACLE | 1 | 1 |
| 217 | | 604 668 | . NUT, steel - self locking hex 1/2-20 | 1 | 1 |
| 218 | | 010 291 | . WASHER, flat - nylafil 5/8 ID x 1-1/4 OD x 1/8 | 1 | 1 |
| 219 | | 039 889 | . NUT, terminal - yellow | 1 | 1 |
| 220 | | 023 084 | CABLE & PLUG ASSEMBLY, jack (consisting of) | 1 | 1 |
| 221 | | 039 878 | . PLUG ASSEMBLY, jack - yellow (consisting of) | 1 | 1 |
| 222 | | 602 160 | . SCREW, self tapping 8-32 x 1/4 | 1 | 1 |
| 223 | | 026 975 | . INSULATOR, jack plug | 1 | 1 |
| 224 | | 101 219 | . PLUG | 1 | 1 |
| 225 | | 602 178 | . SCREW, set 1/4-20 x 3/8 | 2 | 2 |
| 226 | | 019 833 | . STRIP, copper | 1 | 1 |
| 227 | | 023 083 | . CABLE | 1 | 1 |
| 228 | | 039 800 | RECEPTACLE ASSEMBLY, jack - red (consisting of) | 1 | 1 |
| 229 | | 039 768 | . NUT, terminal - red | 1 | 1 |
| 230 | | 010 291 | . WASHER, flat - nylafil 5/8 ID x 1-1/4 OD x 1/8 | 1 | 1 |
| 231 | | 604 668 | . NUT, steel - self locking hex 1/2-20 | 1 | 1 |
| 232 | | 020 015 | . RECEPTACLE | 1 | 1 |
| 233 | | 601 881 | . NUT, steel - hex jam 1/2-20 | 1 | 1 |

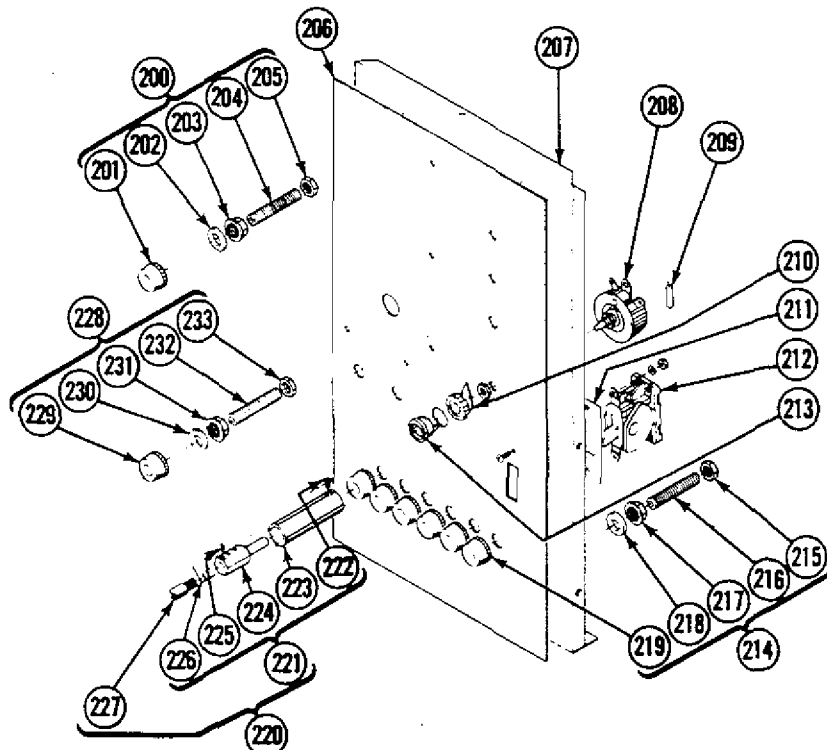
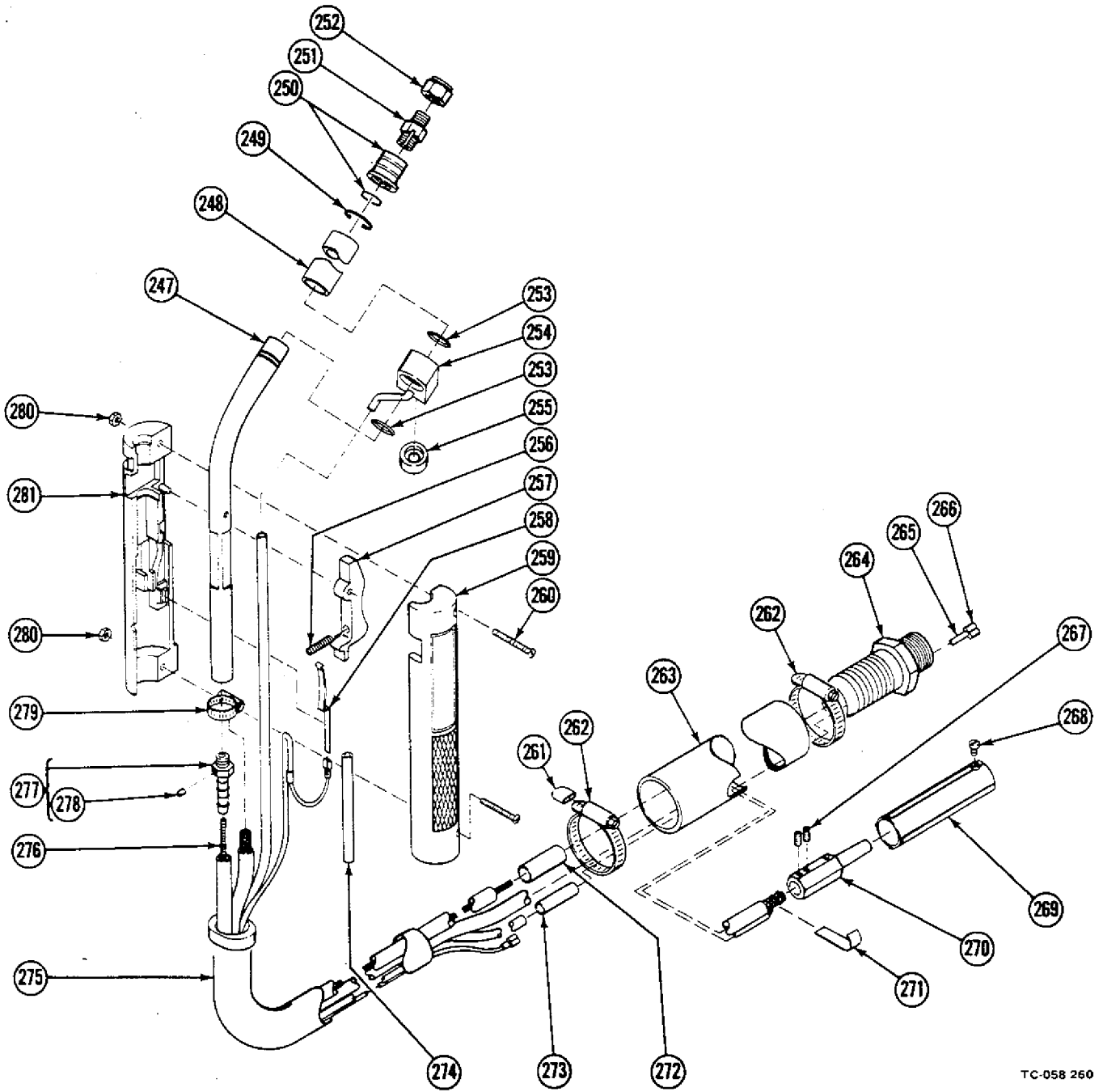

Figure F - Panel, Front With Components

*Recommended Spare Parts

BE SURE TO PROVIDE STOCK, MODEL, AND SERIAL NUMBERS WHEN ORDERING REPLACEMENT PARTS.

TC-023 010



TC-058 260

Figure G - Gun

| Item No. | Dia. Mkgs. | Part No. Listed In Parts List | Replaced With Part No. | Description | Quantity |
|----------|------------|-------------------------------|------------------------|--|----------|
| 11 | T1 | 023 012 | ++007 685 | TRANSFORMER, power main w/115 volt winding | 1 |
| 61 | CR1 | 034 841 | +006 538 | RELAY, 24 volts ac DPDT | 1 |
| 79 | SR2 | 037 346 | +035 914 | RECTIFIER, integrated 25 amp 400 volts | 1 |
| 135 | | 057 536 | ++007 684 | COIL, primary/secondary w/115 volt winding | 1 |
| 146 | FM | 032 678 | ++007 678 | MOTOR, 1/70 hp 115 volts ac 1/4 dia shaft | 1 |
| 247 | | 058 265 | +007 121 | TUBE, head | 1 |
| 253 | | 058 282 | +058 282 | O-RING, (quantity changes) | 4 |
| 272 | | 027 382 | +010 149 | TUBING, steel 1/2 OD x 17 ga wall x 3 | 1 |
| 273 | | 023 953 | +027 713 | TUBING, steel 3/8 OD x 18 ga wall x 2-5/8 | 1 |
| | C7 | | ++003 886 | CAPACITOR, ceramic 0.01 uf 500 volts dc | 1 |
| | R5 | | +006 537 | RESISTOR, WW fixed 12 watt 0.5 ohm | 1 |

+Effective with Serial No. HG039506

++Effective with Serial No. HG057413

BE SURE TO PROVIDE STOCK, MODEL, AND SERIAL NUMBERS WHEN ORDERING REPLACEMENT PARTS.

| Item No. | Dia. Mkgs. | Factory Part No. | Description | Quantity |
|----------|------------|------------------|---|----------|
| Figure G | 058 26" | | Gun (See Fig. A Page 2 Item 28) | |
| 247 | | 058 265 | TUBE, head | 1 |
| 248 | | 058 043 | HOSE, rubber 1/2 ID x 11/16 OD x 4 | 1 |
| 249 | | 605 308 | RING, retaining | 1 |
| 250 | | 058 376 | INSULATOR & RING, nozzle | 1 |
| 251 | | 057 558 | CONNECTOR, male 1/8 MPT 3/16 tube | 1 |
| 252 | | 057 592 | NUT, brass - compression 3/16 TBG | 1 |
| 253 | | 058 282 | O-RING | 2 |
| 254 | | 028 667 | VALVE, gas | 1 |
| 255 | | 058 262 | CAP, valve | 1 |
| 256 | | 057 544 | SPRING, compression | 1 |
| 257 | | 058 259 | TRIGGER, gun | 1 |
| 258 | S3 | 057 557 | SWITCH, leaf | 1 |
| 259 | | 058 257 | HANDLE, gun - right hand | 1 |
| 260 | | 602 111 | SCREW, machine rnd hd 10-24 x 1 | 2 |
| 261 | | 605 383 | CAP, tip - flat | 1 |
| 262 | | 023 952 | CLAMP, hose 1-1/2 dia | 2 |
| 263 | | 057 731 | HOSE, strain relief | 1 |
| 264 | | 032 478 | ADAPTER, insert - nylon | 1 |
| 265 | | 600 401 | WIRE, strained 18 ga (22 inches req)(order by foot) | 2 ft. |
| 266 | | 600 758 | TERMINAL, friction - female | 1 |
| 267 | | 602 178 | SCREW, set 1/2-20 x 3/8 | 2 |
| 268 | | 602 160 | SCREW, self tapping fil hd 8-32 x 1/4 | 1 |
| 269 | | 602 814 | INSULATION, red | 1 |
| 270 | | 101 219 | PLUG, jack | 1 |
| 271 | | 019 833 | STRIP, copper | 1 |
| 272 | | 027 382 | TUBING, fiber 3 inches long | 1 |
| 273 | | 023 953 | TUBING, phenolic 2 inches long | 1 |
| 274 | | 605 928 | TUBING, glass - acrylic No. 9 x 1-1/8 | 1 |
| 275 | | 058 196 | CABLE, combination | 1 |
| 276 | | 058 195 | LINER, electrode | 1 |
| 277 | | 057 781 | COUPLING, male (consisting of) | 1 |
| 278 | | 602 172 | SCREW, set 10-32 x 3/16 | 1 |
| 279 | | 023 562 | CLAMP, hose 5/16 - 7/8 dia. | 1 |
| 280 | | 601 861 | NUT, steel - hex 10-24 | 2 |
| 281 | | 058 258 | HANDLE, gun - left hand | 1 |

BE SURE TO PROVIDE STOCK, MODEL, AND SERIAL NUMBERS WHEN ORDERING REPLACEMENT PARTS.

