



Scan this code or visit [MillerWelds.com/deltaweldsetup](http://MillerWelds.com/deltaweldsetup) to view a video of the Deltaweld 350 integrated cart setup.



## Safety Symbol Definitions



**DANGER!** – Indicates a hazardous situation which, if not avoided, could result in death or serious injury. The possible hazards are shown in the adjoining symbols or explained in the text.



Have only trained and qualified persons install, operate, or service this unit. Read the safety information at the beginning of these instructions and in each section. Call your distributor if you do not understand the directions. For WELDING SAFETY and EMF information, read owner's manual(s).



Falling equipment can injure, and damage equipment. Never put any body part under unit while lifting. Lifting forks must extend out opposite side of base. Lift and support unit only with proper equipment and correct procedures. Follow the guidelines in the Applications Manual for the Revised NIOSH Lifting Equation (Publication No. 94-110) when manually lifting heavy parts or equipment.



Wear safety glasses with side shields.

## Tools Needed



1/2 in., 9/16 in., 3/4 in.

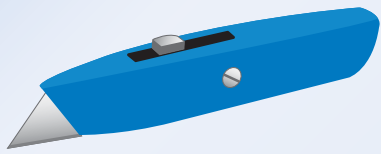

2 x 3/4 in.

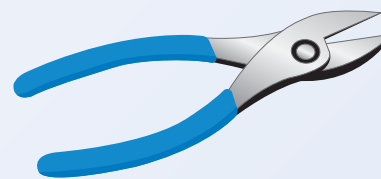

## 1. Getting Started

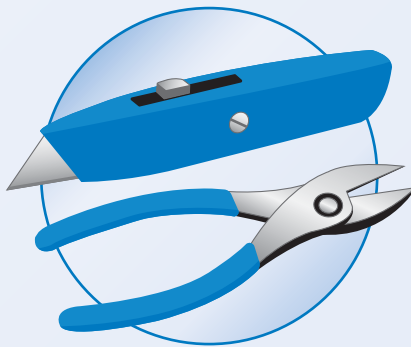
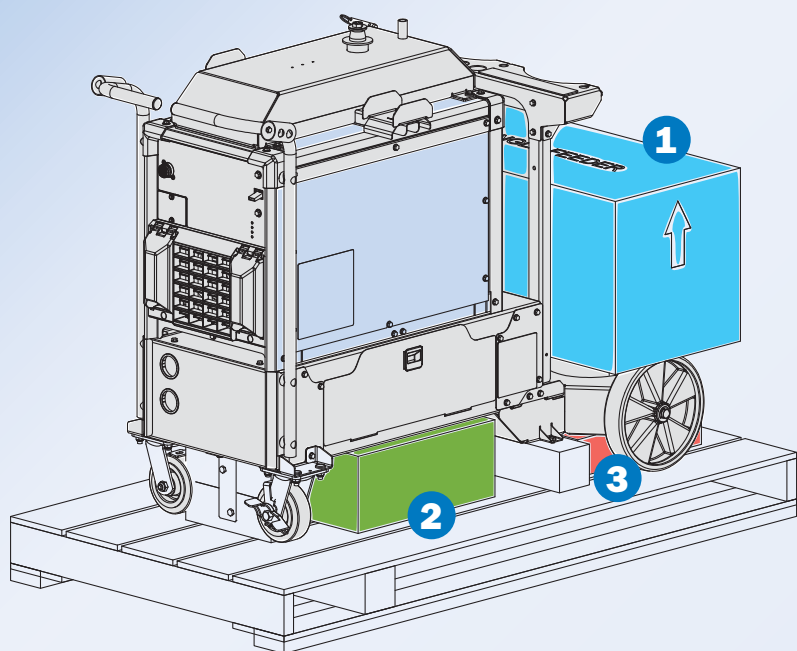

Ensure sufficient room exists behind assembly before removing it from pallet.

Remove shrink wrap. Remove and unbox all packages from the cart. Verify that all parts are present.

- 1 Wire feeder**
- 2 Accessories kit** includes weld cables, gas regulator, gas hose, control cable, drive roll kit, and hardware kit. Hardware kit includes gas bottle chain, 1/2 in. bolt, and washer.
- 3 Bernard™ MIG gun**

## 2. Removing Integrated Cart From Pallet

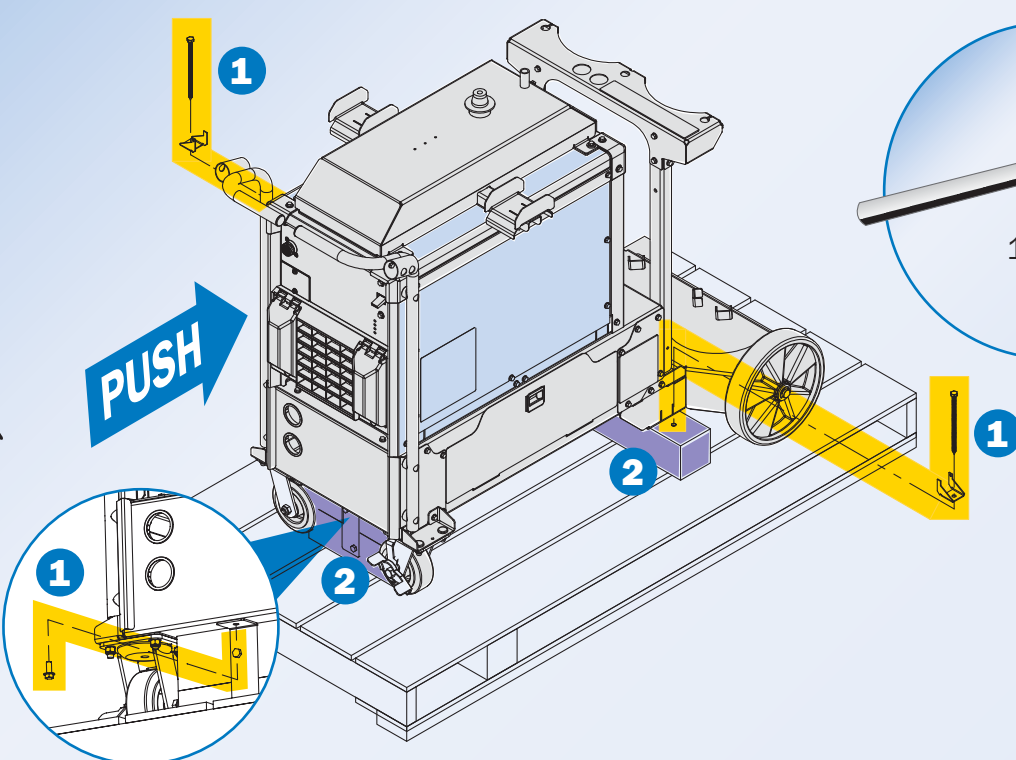
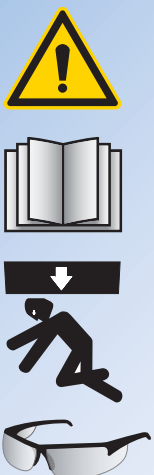

- ! Have only trained and qualified persons install power cable and select input voltage. See welding power source Owner's Manual.**
- ! Do not connect power until assembly is complete. See welding power source Owner's Manual.**

- 1 Remove the two lag bolts and two mounting brackets** from the rear of the cart. Remove the **bolt** from the front underside of the cart.
- 2 Push cart backwards off the front and rear blocks.** When wheels and casters are on the pallet, slide rear block out of the way. Continue to push cart backward until wheels and casters are on the ground.



### 3. Attaching Wire Feeder To Integrated Cart

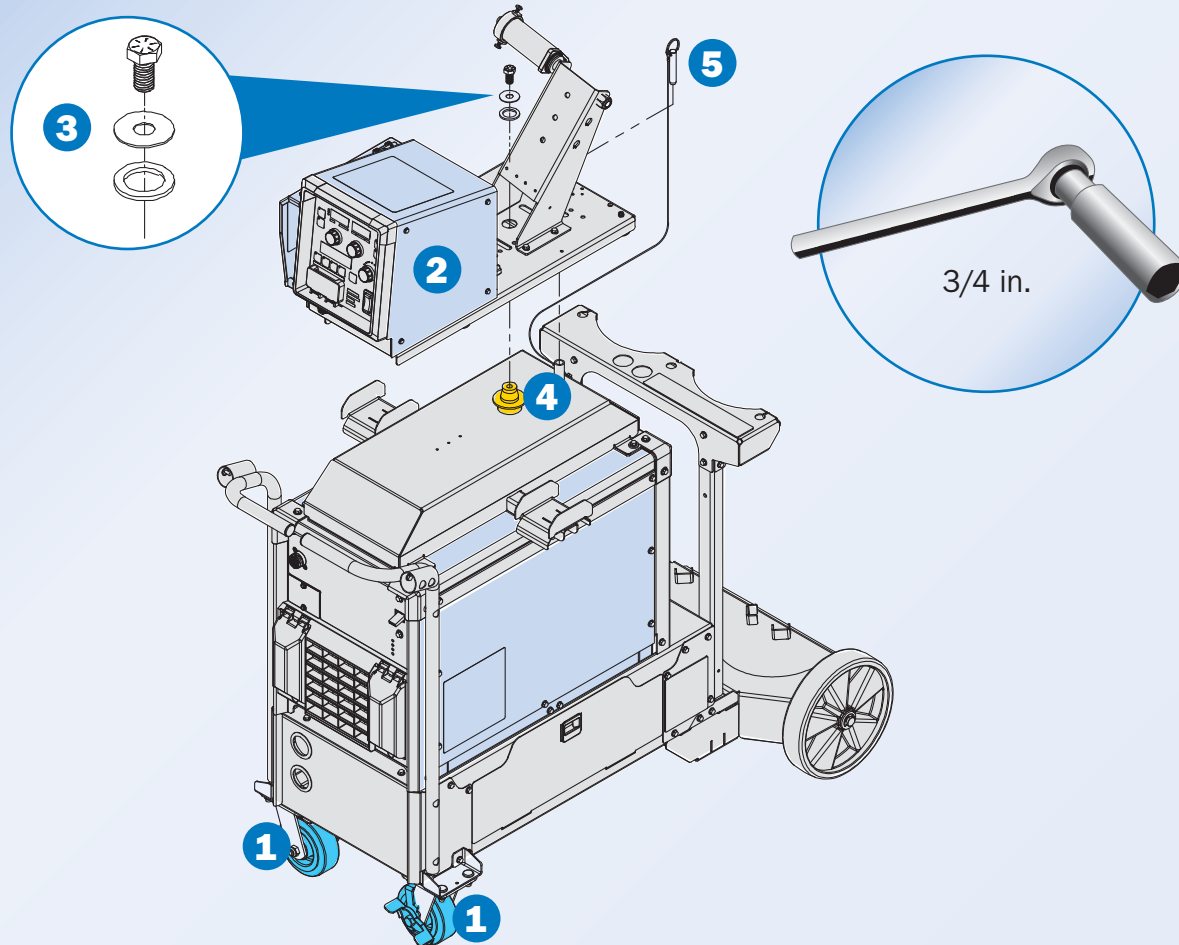

**Do not leave wire feeder unattended until it is secured to the cart.**

- 1 Lock casters.
- 2 Remove **wire feeder** and wire feeder Owner's Manual from box. Discard packaging.
- 3 Obtain **1/2 in. bolt, washer, and spacer** from hardware kit.
- 4 Align hole under wire feeder spool support with **post** on top of cart. Lower feeder onto post. Use 1/2 in. bolt, washer, and spacer to secure feeder to post. Tighten to 21 ft. lb. (28.5 N·m).
- 5 Remove **pin** (leave lanyard secured to back of cart assembly) and insert through hole in feeder base into post on top of the cart upper assembly.

### 4. Installing MIG Gun, Cables, and Gas Cylinder

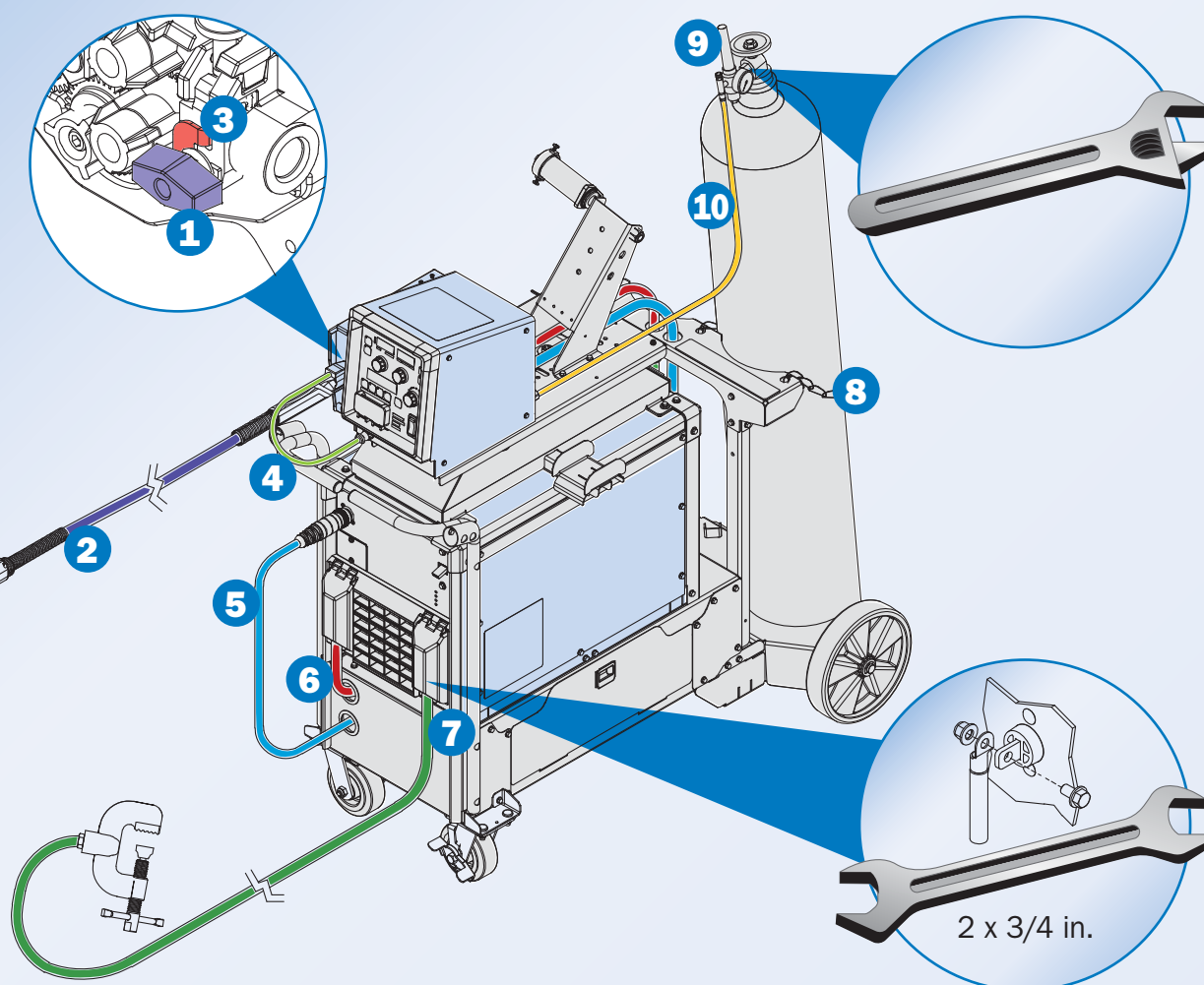

- 1 Loosen **knob** on drive assembly.
- 2 Insert **MIG gun** into drive assembly.
- 3 Align **Accu-Mate™** with groove in gun and tighten knob.
- 4 Align **MIG gun control plug** with connector on feeder. Push on and twist to tighten.
- 5 Align power source end of **control cable** to connector on the front of the welding power source. Push on and twist until it clicks. Route cable through hole in cart base, then up through hole in gas cylinder upper bracket, and underneath the spool support. Align feeder end of cable with connector on the rear of feeder. Push on and twist until it clicks.
- 6 Connect **positive (+) weld cable** (power source side) to positive output stud. Route cable through hole in cart base. Finish routing cable in the same manner as control cable (5).
- 7 Connect **negative (-) weld cable** (power source side) to negative output stud.
- 8 Secure **gas cylinder** with **chain** from hardware kit.
- 9 **Gas regulator** (see installation instructions in box)
- 10 **Gas hose**

### 5. Setting Up Wire Feeder

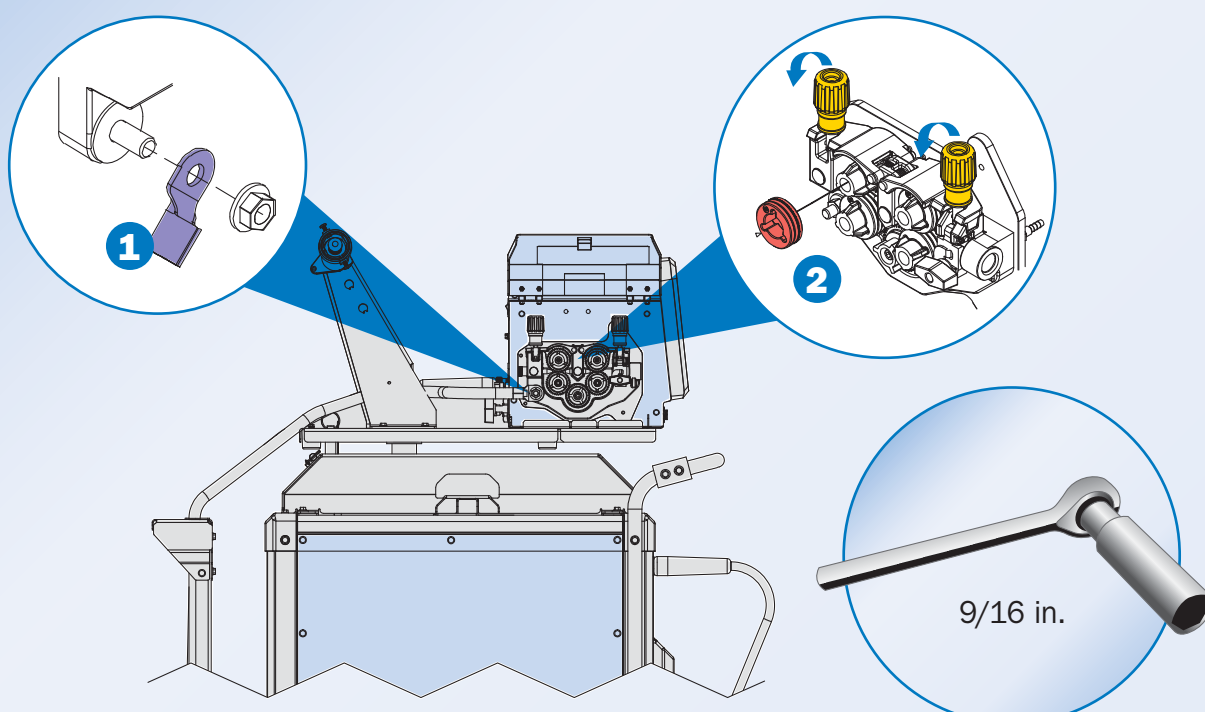

- 1 Connect **positive (+) weld cable** (feeder side) to connection point inside feeder. Tighten to 27–33 ft. lb. (36.6–45 N·m).
- 2 Push down knobs to open drive assembly. Install **drive rolls**.

**Finishing Installation — See Owner's Manual for your specific wire feeder and welding power source for information on connecting input power and operating equipment.**