

4

3

2

1

REFER TO OWNERS MANUAL FOR BOLTING UNIT IN PLACE

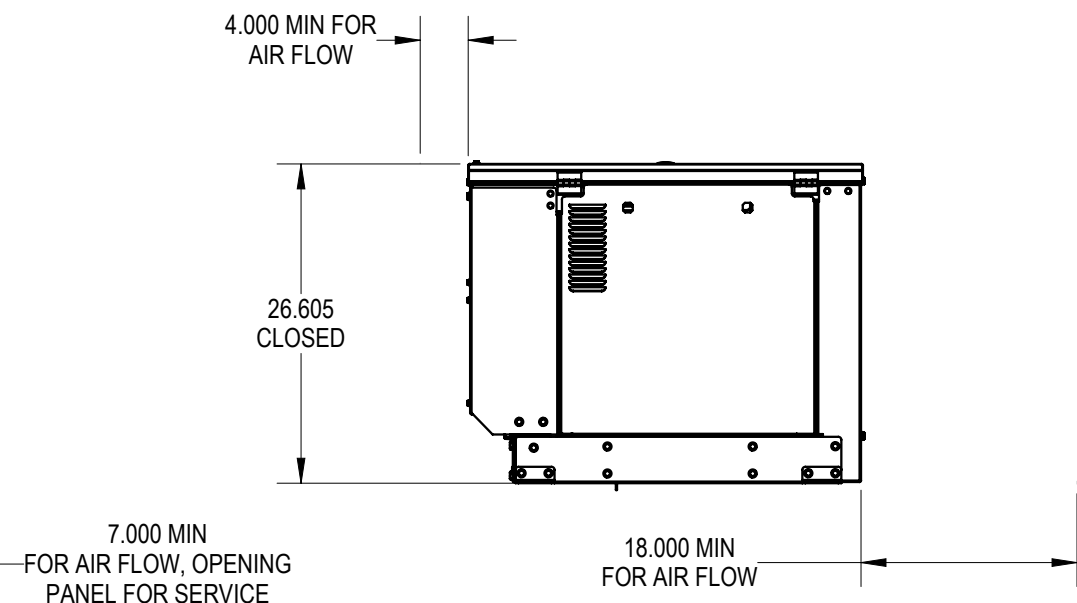
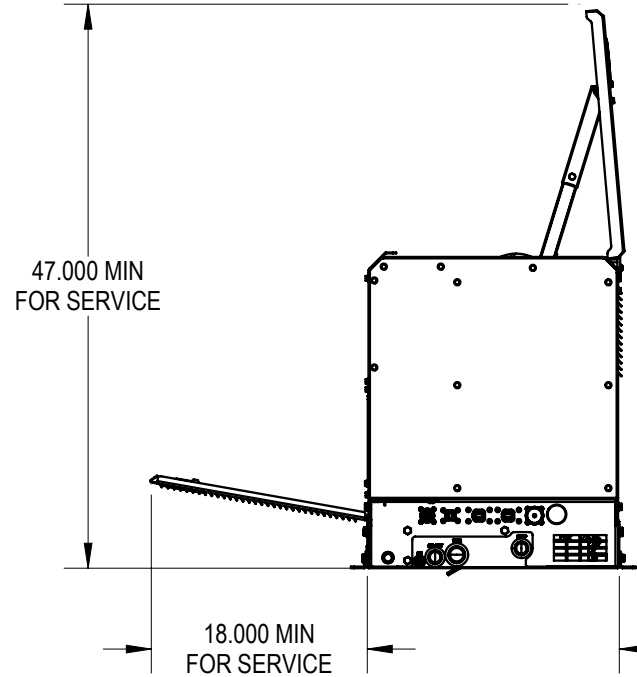
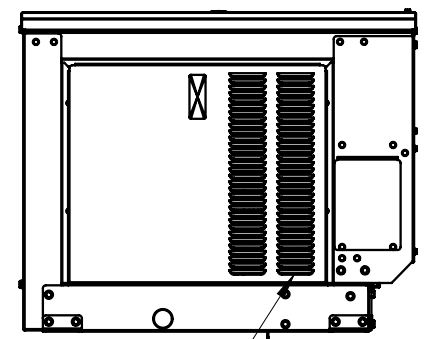
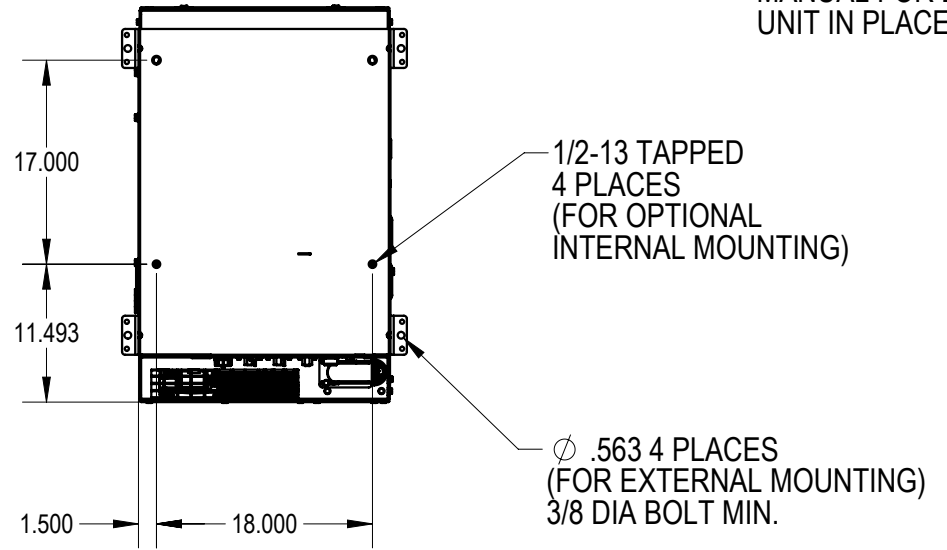
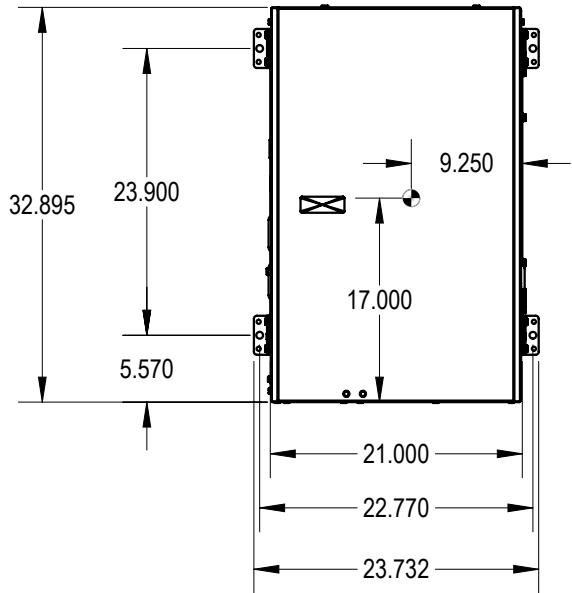
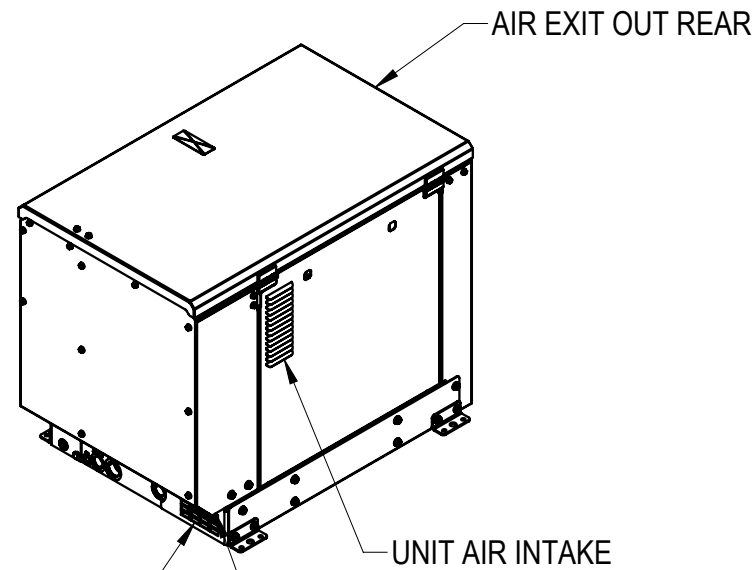

\*RoHS COMPLIANT\*

Rev	Date	By	ECO	Revision Description
B	1/16/2025	TLW GAV	42394	LOCATION FOR CENTER OF MASS ADDED. INCLUDED VIEWS OF TRUCK MOUNTING.

Dimensions are in INCHES Unless Otherwise Specified

Decimal:  
0.X ±  
0.XX ±  
0.XXX ±

Fractional ±  
Angular ±

Machine Finish:

**Miller®**  
MILLER ELECTRIC MFG. LLC, APPLETON, WI. USA An ITW Welding Company

Title: ILLUS, MACHINE LAYOUT (HDI AP)

NOT TO SCALE    CONFIDENTIAL    SHEET: 1 of 1

© MILLER ELECTRIC MFG. LLC ("MILLER"). THIS DOCUMENT FILE AND THE INFORMATION CONTAINED THEREIN ("MATERIAL") IS MILLER PROPRIETARY AND CONFIDENTIAL INFORMATION AND SHALL NOT BE DUPLICATED OR DISTRIBUTED WITHOUT MILLER'S EXPRESS WRITTEN CONSENT. THIS MATERIAL SHALL BE USED SOLELY FOR THE PURPOSE SET FORTH BY MILLER AND SHALL BE RETURNED TO MILLER UPON REQUEST.

Orig. Dwn. By: TW	Date: 07/30/24	Size: B	Drawing No: 298013	Rev: B
Rev. Appvd. By: GV	Date: 01/14/25			

4

3

2

1

B

B

A

A