

# SECTION 1 – ASSEMBLY SAFETY PRECAUTIONS

safety\_trailer\_2018-01

 Protect yourself and others from injury — read, follow, and save these important safety precautions and operating instructions.

## 1-1. Symbol Usage



**DANGER!** – Indicates a hazardous situation which, if not avoided, will result in death or serious injury. The possible hazards are shown in the adjoining symbols or explained in the text.



Indicates a hazardous situation which, if not avoided, could result in death or serious injury. The possible hazards are shown in the adjoining symbols or explained in the text.

**NOTICE** – Indicates statements not related to personal injury.

 Indicates special instructions.



This group of symbols means Warning! Watch Out! ELECTRIC SHOCK, MOVING PARTS, and HOT PARTS hazards. Consult symbols and related instructions below for necessary actions to avoid the hazards.

## 1-2. Assembly Hazards



The symbols shown below are used throughout this manual to call attention to and identify possible hazards. When you see the symbol, watch out, and follow the related instructions to avoid the hazard. The safety information given below is only a summary of the more complete safety information found in the Safety Standards. Read and follow all Safety Standards.



Only qualified persons should install, operate, maintain, and repair this equipment. A qualified person is defined as one who, by possession of a recognized degree, certificate, or professional standing, or who by extensive knowledge, training and experience, has successfully demonstrated ability to solve or resolve problems relating to the subject matter, the work, or the project and has received safety training to recognize and avoid the hazards involved.



During operation, keep everybody, especially children, away.



### FALLING EQUIPMENT can injure.

- Use correct procedures and equipment of adequate capacity to lift and support unit.
- If using lift forks to move unit, be sure forks are long enough to extend beyond opposite side of unit.
- Follow the guidelines in the Applications Manual for the Revised NIOSH Lifting Equation (Publication No. 94-110) when manually lifting heavy parts or equipment.



Read and follow all Trailer Towing Safety Information at the beginning of manual before using this trailer.

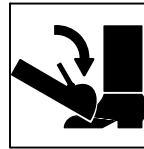

### TILTING OF TRAILER can injure.

- Use tongue jack or blocks to support weight.
- Properly install welding generator onto trailer according to instructions.

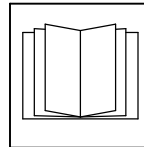

### READ INSTRUCTIONS.

- Read and follow all labels and the Owner's Manual carefully before installing, operating, or servicing unit. Read the safety information at the beginning of the manual and in each section.
- Use only genuine replacement parts from the manufacturer.
- Perform installation, maintenance, and service according to the Owner's Manuals, industry standards, and national, state, and local codes.

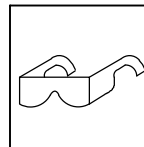

### FLYING METAL OR DIRT can injure eyes.

- Wear approved safety glasses with side shields when assembling and maintaining trailer.

# SECTION 2 – TRAILER TOWING SAFETY PRECAUTIONS

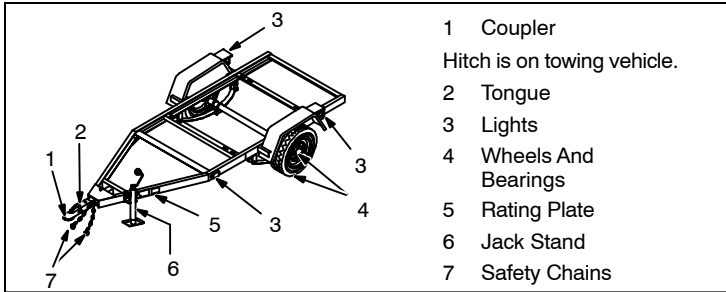

- 1 Coupler  
Hitch is on towing vehicle.
- 2 Tongue
- 3 Lights
- 4 Wheels And Bearings
- 5 Rating Plate
- 6 Jack Stand
- 7 Safety Chains

- Use a towing vehicle prepared and capable of handling the load.
- Be sure load is properly secured. Load includes welder/generator, cables, tools, and approved accessories.
- Towing any trailer requires special awareness because of the changed driving situation.
- When towing, it takes longer to start, stop, and pass – use training and practice to avoid accidents.
- Turning and backing up present new problems – plan ahead.
- Require each driver to be fully trained and experienced in trailer towing before going out on the road.
- Holes are provided for mounting weld/power generator.
- Be sure trailer is fully prepared and connected to towing vehicle.
- Observe maximum speed of 45 mph (72 kph) when towing.
- Do not modify or change the trailer in any way – changes void the warranty. Read Owner's Manual.
- Use only genuine factory parts as replacements.
- Adjust load on trailer so tongue weight is approximately 10% of the gross trailer weight and center load side-to-side to reduce fishtailing.
- Tighten all parts, bolts, nuts, and mounting hardware.

**WARNING – TRAILER TOWING can be hazardous.** In trailer towing, as in most driving situations, exposure to certain hazards occurs. Trailer towing is safe when precautions are taken. The following safety information is only a summary of the more complete information found in the Safety Standards listed at the end of these precautions. Read and follow all Safety Standards. In addition, the end user must check and comply with all federal, state, and local laws before use.

**Only qualified persons should install, operate, maintain, and repair this equipment.** A qualified person is defined as one who, by possession of a recognized degree, certificate, or professional standing, or who by extensive knowledge, training and experience, has successfully demonstrated ability to solve or resolve problems relating to the subject matter, the work, or the project and has received safety training to recognize and avoid the hazards involved.

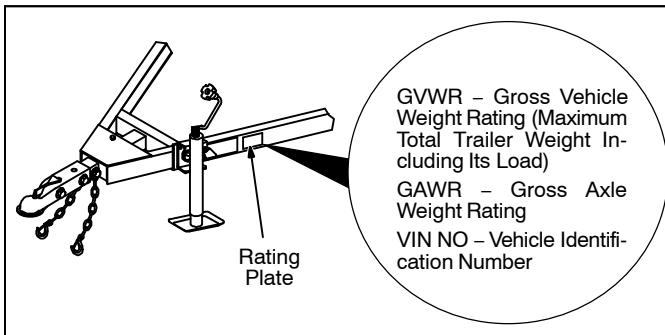

GVWR – Gross Vehicle Weight Rating (Maximum Total Trailer Weight Including Its Load)  
 GAWR – Gross Axle Weight Rating  
 VIN NO – Vehicle Identification Number

**OVERLOADING can cause serious injury or equipment damage.**

- Do not overload the trailer.
- The Gross Vehicle Weight Rating (GVWR) is the maximum total trailer weight with the engine driven welding generator and all equipment, such as tools, cables, and shielding gas cylinder, installed.
- The Gross Axle Weight Rating (GAWR) is the maximum load-bearing capacity of the axle(s).
- Weigh trailer – adjust weight by removing accessory equipment if necessary – call local authorities for nearest scale location.
- Use gross trailer weight to select a proper towing vehicle.

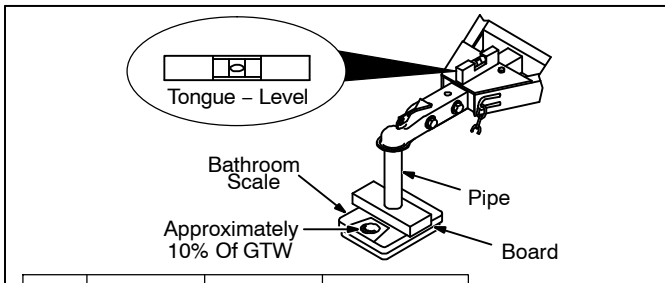

Tongue – Level  
 Bathroom Scale  
 Pipe  
 Board  
 Approximately 10% Of GTW

Trailer And Coupler Class <sup>1</sup>	Gross Vehicle Weight Rating GVWR <sup>2</sup> lb (kg)	Gross Trailer Weight GTW <sup>2</sup> lb (kg)	Maximum Tongue Weight <sup>3</sup> lb (kg)
1	Up to 2000 (Up to 910)	1000 (455) 2000 (910)	100 (45) 200 (90)
2	2000 to 3500 (910 to 1590)	2000 (910) 3500 (1590)	200 (90) 350 (158)
3	3500 to 5000 (1590 to 2270)	3500 (1590) 5000 (2268)	350 (158) 500 (227)

<sup>1</sup> Information From SAE J684 May 2014  
<sup>2</sup> Gross Trailer Weight (Actual Loaded Weight)  
<sup>3</sup> 10% Of GTW Recommended

**UNCONTROLLED TILTING OF TRAILER can result in personal injury or equipment damage.**

- Install generator according to Owner's Manual with engine end toward hitch end of trailer.
- Distribute weight so that trailer tongue weight is approximately 10% of the gross trailer weight.

**INCORRECT TONGUE WEIGHT can cause fishtailing and loss of control of towing vehicle resulting in serious injury and equipment damage.**

- Tongue weight is the amount of trailer weight that rests on the towing vehicle hitch – that is, the downward pressure on the coupler.
- Remove or adjust trailer load to get correct tongue weight.
- Do not let tongue weight exceed coupler and hitch rating.
- Use slower speeds when towing a trailer – never above 45 mph (72 km/h) – to prevent fishtailing.

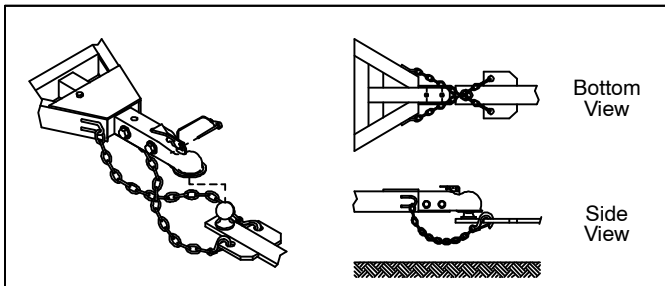

Bottom View  
 Side View

**SAFETY CHAINS CAN PREVENT RUNAWAY TRAILER in case hitch/coupler fails.**

- Always use safety chains when towing.
- Cross safety chains under coupling to prevent tongue from dropping to ground.
- Allow only enough slack for tight turns.
- Do not let safety chains drag on ground.
- Twist safety chains equally from hook ends to take up slack.
- Use safety chains rated equal to or greater than twice the maximum gross trailer weight rating.

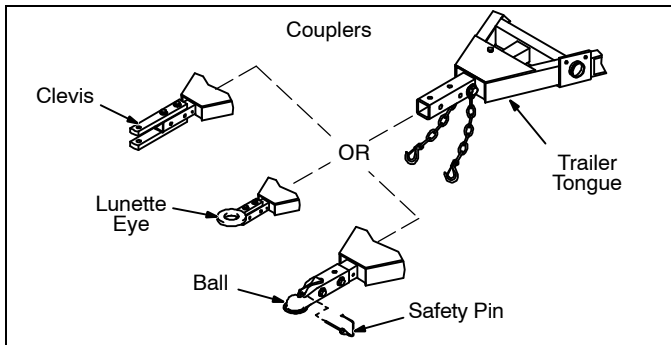

**⚠️ INCORRECT SIZE OR RATING OF HITCH can cause trailer to break loose from towing vehicle.**

- Be sure towing vehicle hitch is correct type, size, and rating to match coupler.
- Be sure the hitch is properly installed onto towing vehicle.
- On optional ball couplers, always insert hitch safety pin before towing.
- Make sure hitch and ball are properly sized and match each other.

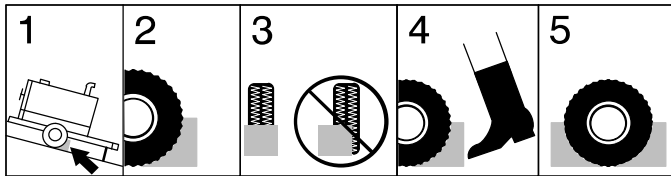

**⚠️ WHEELS MUST BE CHOCKED when trailer is uncoupled from vehicle.**

- Chock in direction of grade.
- Position chock snugly behind tire.
- Place chock square to the tire.
- Tap chock into place.
- For added protection, chock both sides of tire.

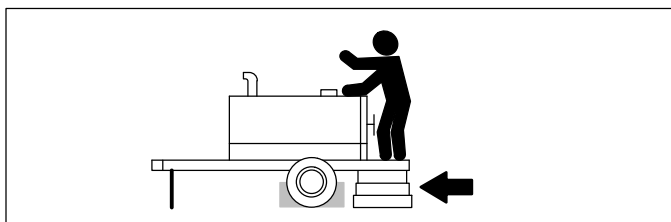

**⚠️ UNEXPECTED TILTING OF TRAILER can cause injury and damage.**

- When trailer is uncoupled from towing vehicle, use jack on front and block rear to prevent tilting.
- Use proper blocks that are large enough and able to support the necessary weight.
- Always chock the wheels when uncoupled.

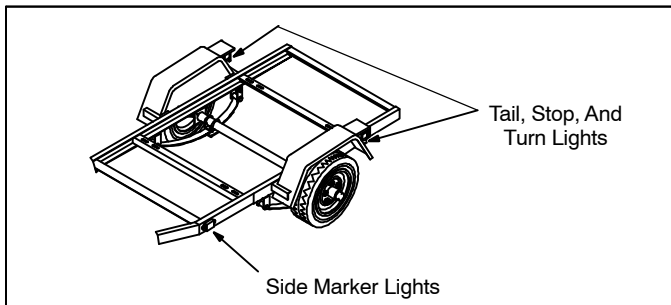

**⚠️ LIGHTS THAT ARE NOT WORKING can cause accidents.**

- State and Federal regulations require trailers used on highways to have tail, stop, turn, and side marker lights.
- Lights are not required for trailers designed for off-road use only.
- Check all lights and connectors for proper installation and operation before using the trailer.
- Check condition of wiring harness leads, plugs, and connections regularly. Repair or replace damaged parts or wires.
- Replace any broken lenses, reflectors, or bulbs.

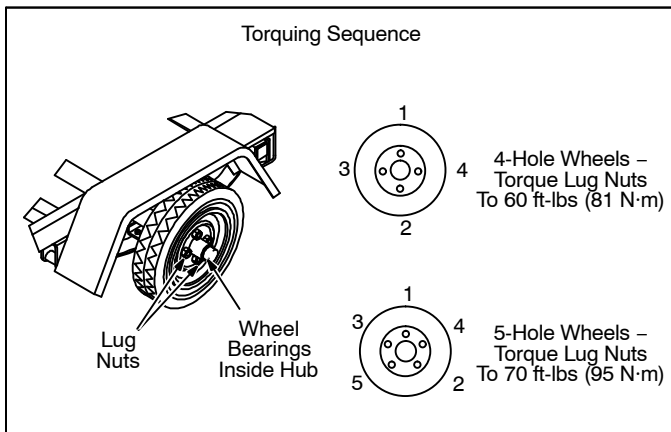

**⚠️ INCORRECT TORQUE on lug nuts or INCORRECT TIRE PRESSURE or BEARING MAINTENANCE can cause loss of control resulting in serious injury and equipment damage.**

- Recheck lug nut torque after first 50 miles (80 km) and once each year or every 12,000 miles (19,500 km) thereafter, whichever comes first.
- When checking lug nuts, keep them clean, dry, and unlubricated.
- Check and repack wheel bearings once each year or every 12,000 miles (19,500 km), whichever comes first.
- Maintain correct tire pressure according to sidewall data on tire – underinflation is the most common cause of tire trouble.
- Check tires for wear every six months.
- Use only replacement tires of the same size, rating, and capacity.

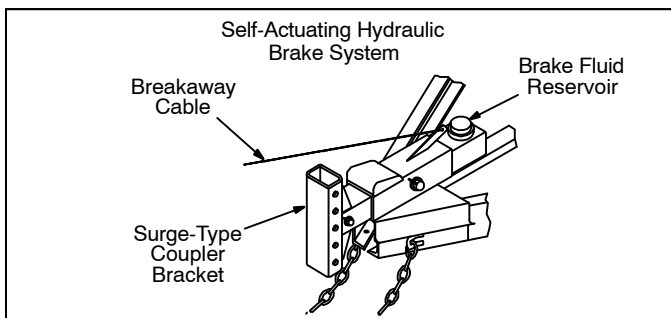

**⚠️ INOPERATIVE SURGE-TYPE BRAKES OR WRONG BREAKAWAY CABLE CONNECTION can cause accidents.**

- Check brake fluid level before use.
- Do not use sway control devices – keep coupler free to telescope during braking.
- Always connect breakaway cable to towing vehicle – be sure it has a direct free pull.
- Do not wrap cable around safety chains, tongue, wiring, or any other parts.
- The breakaway cable automatically applies the trailer brakes if separation occurs.

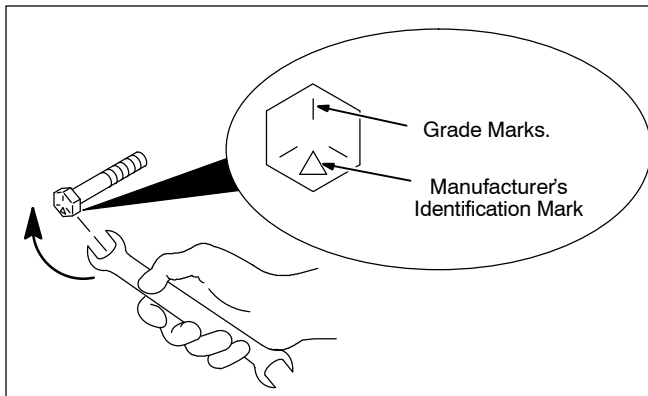

**⚠ LOOSE OR INCORRECT HARDWARE AND FASTENERS can injure, and damage equipment.**

- Periodically double-check all nuts and bolts for tightness and condition.
- If necessary, always replace any fastener with one of equal size, grade, and type.
- Be sure the grade marks on replacement fastener match the original bolt. The manufacturer's identification mark is not critical and does not matter for the replacement fastener.

### PRE-TOWING CHECKLIST

- Check gross trailer weight, tongue weight, and total weight distribution – do not overload this trailer.
- Check that the correct hitch is properly installed on towing vehicle.
- When coupling, check that coupler locking device (safety pin), safety chains, and breakaway cable (if applicable) are properly connected.
- Check that tires are properly inflated and that wheel nuts are properly torqued.
- If applicable, check that all lights are working properly.
- Be sure tongue jack (if equipped) is retracted.

### CALIFORNIA PROPOSITION 65 WARNINGS

**⚠ WARNING: This product can expose you to chemicals including lead, which are known to the state of California to cause cancer and birth defects or other reproductive harm.**

For more information, go to [www.P65Warnings.ca.gov](http://www.P65Warnings.ca.gov)

### PRINCIPAL SAFETY STANDARDS

*Towing a Trailer – Being Equipped for Safety*, Publication from U.S. Department of Transportation, National Highway Traffic Safety Administration, 1200 New Jersey Ave., SE, Washington D.C. 20590 (phone: 1-800-424-9071), website: [www.fhwa.dot.gov](http://www.fhwa.dot.gov)).

*Safety and Health Standards*, Title 49 CFR 200 to 999, from Superintendent of Documents, U.S. Government Printing Office, Superintendent of Documents, P.O. Box 371954, Pittsburgh, PA 15250-7954 (phone: 1-866-512-1800)

*Applications Manual for the Revised NIOSH Lifting Equation*, The National Institute for Occupational Safety and Health (NIOSH), 1600 Clifton Rd, Atlanta, GA 30329-4027 (phone: 1-800-232-4636, website: [www.cdc.gov/NIOSH](http://www.cdc.gov/NIOSH)).

*Trailer Couplings, Hitches, and Safety Chains – Automotive Type*, SAE Standard J684, from SAE International, 400 Commonwealth Drive Warrendale, PA 15096 (phone: 877-606-7323, website: [www.sae.org](http://www.sae.org)).

### REPORTING SAFETY DEFECTS

If you believe that your vehicle has a defect which could cause a crash or could cause injury or death, you should immediately inform the National Highway Traffic Safety Administration (NHTSA) in addition to notifying MILLER Electric Mfg. Co.

If NHTSA receives similar complaints, it can open an investigation, and if it finds that a safety defect exists in a group of vehicles, it can order a recall and remedy campaign. However, NHTSA cannot become involved in individual problems between you, your dealer, or MILLER Electric Mfg. Co.

To contact NHTSA, you can call the Auto Safety Hotline toll-free at 1-888-327-4236, visit the website at [www.nhtsa.gov](http://www.nhtsa.gov) or write to: NHTSA, 1200 New Jersey Ave. SE, Washington D.C. 20590. You can also obtain other information about motor vehicle safety from these sources.