

FIELD INSTRUCTIONS

2015-04

FORM: F270 922A

Use above FORM number when ordering extra manuals.

Balance Selection For Applications Without SubArc Digital Interface For SubArc Digital Power Sources: 907620 And 907621 With Field Kit 301292

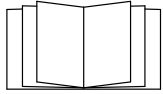

Have only trained and qualified persons install, operate, or service this unit. Call your distributor or the equipment manufacturer if you do not understand the directions. For WELDING SAFETY and EMF information, read Owner's Manual.

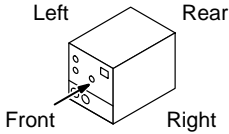

All directions are given as facing front panel.
Keep hardware for reuse.

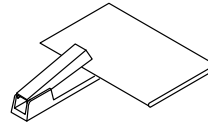

Staple these instructions inside Owner's Manual.

1. Safety Symbol Definitions

	<p>DANGER! – Indicates a hazardous situation which, if not avoided, will result in death or serious injury. The possible hazards are shown in the adjoining symbols or explained in the text.</p> <p style="text-align: right;"><small>Fsafe1 2013-10</small></p>		<p>Beware of electric shock from wiring. Disconnect input power before installing this kit. Reinstall all panels and covers.</p> <p style="text-align: right;"><small>Fsafe7 2013-10</small></p>
	<p>Indicates a hazardous situation which, if not avoided, could result in death or serious injury. The possible hazards are shown in the adjoining symbols or explained in the text.</p> <p style="text-align: right;"><small>Fsafe2 2013-10</small></p>		<p>Wear safety glasses with side shields.</p> <p style="text-align: right;"><small>Fsafe8 2013-10</small></p>
<p>NOTICE</p>	<p>Indicates statements not related to personal injury.</p> <p>Indicates special instructions.</p> <p style="text-align: right;"><small>Fsafe3 2013-10</small></p>		

CALIFORNIA PROPOSITION 65 WARNINGS

Welding or cutting equipment produces fumes or gases which contain chemicals known to the State of California to cause birth defects and, in some cases, cancer. (California Health & Safety Code Section 25249.5 et seq.)

This product contains chemicals, including lead, known to the state of California to cause cancer, birth defects, or other reproductive harm. Wash hands after use.

Fsafe4 2013-10

2. Tools Needed

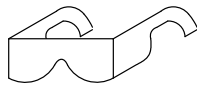

3. Download Software

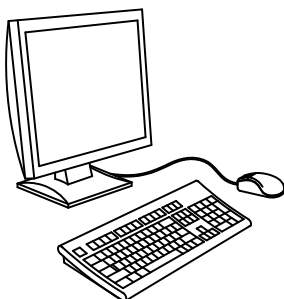

A computer with an SD memory card port or SD memory card reader is required to download software updates. Download updates at www.Miller-Welds.com. (or, update software with a purchased software update card – stock no. 301292).

The SD logo is a registered trademark of SD-3C LLC.

5. Installing Balance SD Card For AC/DC Power Source Models

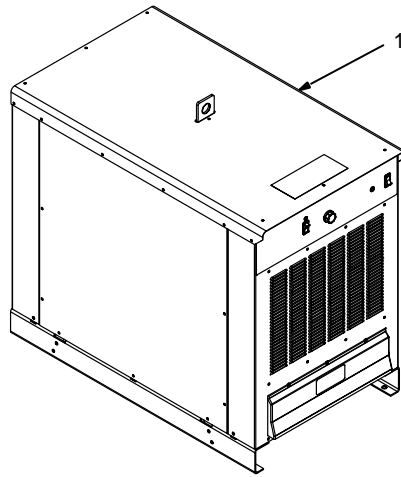

- Turn off welding power source.
- Disconnect and lockout/tagout input power before removing covers or panels and working inside unit. Follow established procedures regarding the installation and removal of lockout/tagout devices.
- This procedure requires an energized unit. Have only personnel familiar with and following standard safety practices do the job.

1 Cover

Remove cover.

2 SD Card Reader

Insert Balance SD card into SD card reader located on left side of unit. Push in SD card, and it will lock in place.

Welding output will now be selected balance.

Balance SD card must remain in machine for balance selection to work.

Reinstall cover using existing hardware.

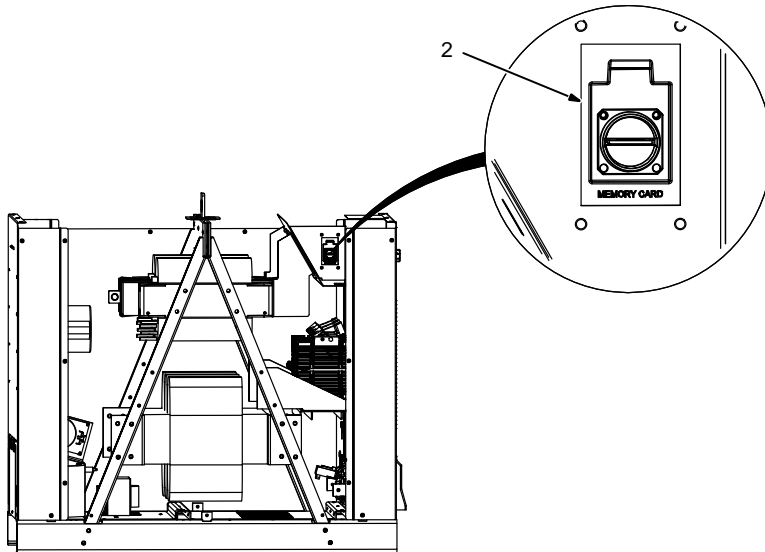

Side panel shown removed for ease in illustration.
Panel does not have to be removed to insert SD card.