

Millermatic® 211

MIG Power Source,
Wire Feeder and Gun Package 

Quick Specs

Light Industrial Applications

Light fabrication
Maintenance and repair
Auto body
Farm/home

Processes

MIG (GMAW)
Flux-cored (FCAW)

Weld Thickness

120 V: 24 ga.–3/16 in. steel
18 ga.–1/8 in. aluminum
240 V: 24 ga.–3/8 in. steel
18 ga.–3/8 in. aluminum

Input Power

120 V: 24.3 A, single-phase, 50/60 Hz
240 V: 16.6 A, single-phase, 50/60 Hz

Rated Output

120 V: 115 A at 19.8 VDC, 20% duty cycle
240 V: 150 A at 21.5 VDC, 40% duty cycle

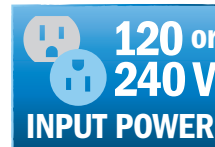

Uses 120- or 240-volt power



Portable

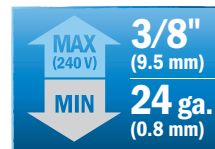

MIG weld capacity



Quick and easy setup

AccuLock™

Includes **MDX™-100 MIG gun with AccuLock™ MDX consumable system** featuring a dual-locked, front-loading liner that optimizes wire feedability.

Advanced Auto-Set™ includes five different wire/gas combinations and three wire size capabilities.

- Wire/gas combinations include Flux Cored, Mild Steel with 100% CO₂, Mild Steel with C25, Stainless Steel, and Aluminum with spool gun
- Select the wire type and gas being used
- Set the wire diameter (.024, .030 or .035 in.). A blue LED indicates that Auto-Set is activated
- Dial in the thickness of what you're welding
- Start welding with the exact parameters you need!

Inverter technology combines best-in-class arc characteristics with the portability of a 38-pound machine. The arc is extremely forgiving to variations in arc length and travel speeds.

Multi-voltage plug (MVP™)

allows connection to common 120- and 240-volt power receptacles without the use of any tools — simply choose the plug that fits the receptacle and connect to the power cord.



Angled cast-aluminum drive system with calibrated tension knob creates consistent feeding and easy setup.

Quick Select™ drive roll makes setup quicker by offering three grooves — two for different size solid wire and a third for flux-cored wire.

Auto Spool Gun Detect™ automatically detects when a MIG gun or spool gun is connected, eliminating the need for a switch.

Fan-On-Demand™ cooling system only operates when needed, reducing noise, energy use and contaminants pulled through the machine.

Smooth-Start™ provides a smooth, spatter-free start. It's the best-starting machine in the small MIG machine category.

Thermal overload protection shuts down unit and activates the **over temperature light** if airflow is blocked or duty cycle is exceeded. Automatically resets when unit cools.

Uses 4- or 8-inch (102 or 203 mm) spools and can be set up to weld with .024–.035 inch (0.6–0.9 mm) solid wire and .030–.045 inch (0.8–1.2 mm) flux-cored wire.

Comes complete with:

- Power source
- 10 ft. (3 m) MDX™-100 MIG gun
- 10 ft. (3 m) work cable with clamp
- 6.5 ft. (2 m) power cord with MVP™ plugs for 120 V and 240 V
- Flow gauge regulator and gas hose for argon or AR/CO₂ mix
- Hobart® spool of .030 in. (0.8 mm) solid wire
- Two contact tips for .030 in. (0.8 mm) wire
- Quick Select™ drive rolls for .024 in. (0.6 mm) or .030/.035 in. (0.8/0.9 mm) solid wire, and .030/.035 in. (0.8/0.9 mm) flux-cored wire
- Material thickness gauge ▶ 229895
- Hook-and-loop cord wraps

Note: Shielding gas and safety equipment not included.



Welder is warrantied for three years, parts and labor.
Gun warrantied for 90 days, parts only.



Miller Electric Mfg. LLC
An ITW Welding Company
1635 West Spencer Street
P.O. Box 1079
Appleton, WI 54912-1079 USA

Equipment Sales US and Canada
Phone: 866-931-9730
FAX: 800-637-2315
International Phone: 920-735-4554
International FAX: 920-735-4125

MillerWelds.com



Operation Modes

Auto-Set™ mode

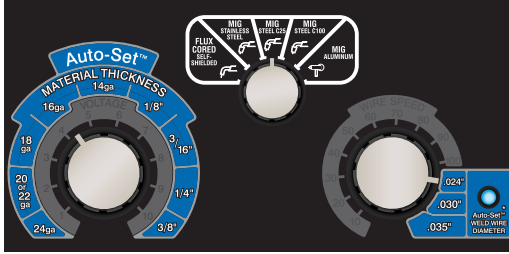

Auto-Set eliminates guesswork and saves you time on setup. Turn wire selector knob to select the wire and gas combination being used. Turn wire speed control fully clockwise to select Auto-Set mode and set the wire diameter to either .024, .030 or .035 inch. The Auto-Set light indicates mode is activated. Then select material thickness using the Auto-Set control.

Use Auto-Set when you want the speed, convenience and confidence of pre-set controls. Auto-Set automatically sets your welder to the proper parameters. It's available for welding with .024-, .030- and .035-inch steel and stainless steel wires, .030- and .035-inch flux-cored wires, and .030- and .035-inch 4043 aluminum wires with the Spoolmate 100 spool gun. Shielding gas is dependent on the wire being used.

Manual mode

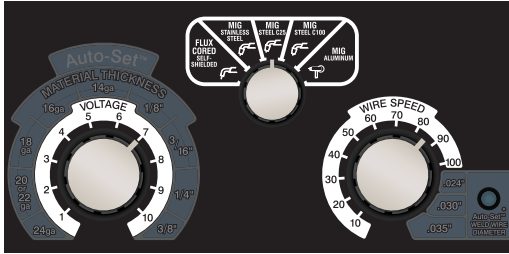

When welding outside of Auto-Set capabilities, or if you prefer custom parameters, use manual mode. The parameter chart on the inside of the access door is an easy-to-use guide for determining your voltage and wire feed speed settings. To optimize arc starts, turn wire selector knob to select the wire and gas combination being used. Reference the white areas on the controls when welding in manual mode.



Specifications (Subject to change without notice.)



Input Power	Amperage Range	Rated Output	Amps Input at Rated Output, 50/60 Hz				Wire Feed Speed	Wire Type and Diameter	Max. Open-Circuit Voltage	Dimensions	Net Weight
			120 V	240 V	KVA	KW					
120 V	30–130 A	115 A at 19.8 VDC, 20% duty cycle	24.3	—	2.9	2.9	60–600 ipm (1.5–15.2 m/min.)	Solid/stainless: .024–.035 in. (0.6–0.9 mm) Flux-cored: .030–.045 in. (0.8–1.2 mm)	54	H: 12.5 in. (318 mm) W: 11.25 in. (286 mm) D: 20.5 in. (521 mm)	38 lb. (17.2 kg) 42 lb. (19.1 kg) with gun
240 V	30–230 A	150 A at 21.5 VDC, 40% duty cycle	—	16.6	4.0	4.0					

Certified by Canadian Standards Association to both the Canadian and U.S. Standards.

Control Panel

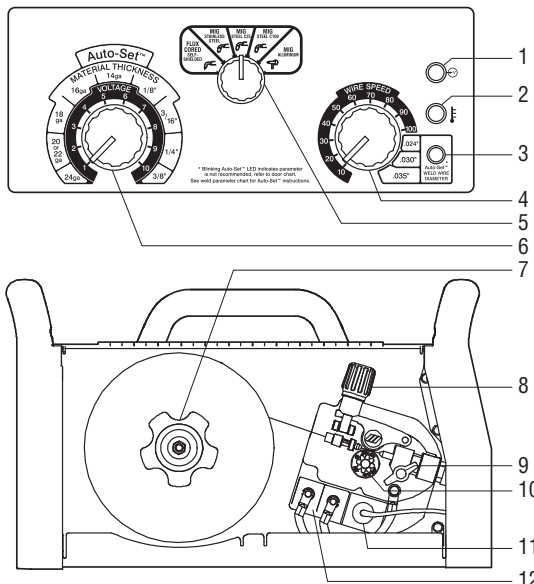

1. Power On Light
2. Over Temperature Light
3. Auto-Set Light
4. Wire Speed/Wire Diameter Control
5. Wire Selector Knob
6. Voltage/Material Thickness Control
7. Plastic Hub with Retaining Ring for 8-inch Spools (shaft also accepts 4-inch spools)
8. Calibrated Tension Knob
9. T-Knob (secures torch)
10. Drive Roll
11. Trigger Control Connector
12. Polarity Changeover Terminals

Note: Power switch and gas solenoid are on machine back panel.

Performance Data

Duty Cycle Chart

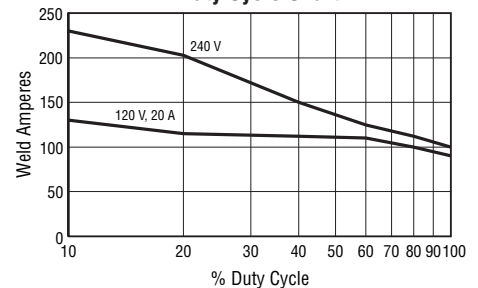

Volt/Amp Curves

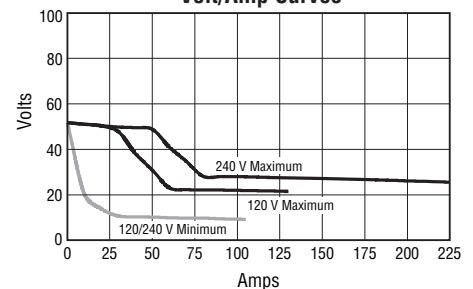

Genuine Miller® Accessories



MDX™-100 MIG Gun 1770028

100-amp MIG gun with Miller® AccuLock™ MDX consumables for .030–.035 in. (0.8–0.9 mm) wire. Includes 10 ft. (3 m) cable assembly.

- Install AccuLock contact tips with a single turn.
- AccuLock liner locks at front and back of gun to align with contact tip and power pin for a flawless wire feed path.
- Durable, ergonomic handle with overmolding improves grip and comfort.
- Ball-and-socket handle with rear swivel for increased gun maneuverability while reducing welder fatigue.



Spoolmate™ 100 Spool Gun 300371

Direct-connect spool gun handles .030–.035 inch (0.8–0.9 mm) aluminum (4043 only) and .023–.035 inch

(0.6–0.9 mm) steel/stainless steel wires. Rated at 135 amps, 30 percent duty cycle. Includes 12-foot (3.7 m) cable assembly and custom carrying case.



Spoolmate™ 150 Spool Gun 301272

Direct-connect spool gun handles .030–.035 inch (0.8–0.9 mm) 4000/5000 series

aluminum and .023–.035 inch (0.6–0.9 mm) steel/stainless steel wires. Rated at 150 amps, 60 percent duty cycle. Includes 20-foot (6.1 m) cable assembly.



Running Gear/Cylinder Rack 301239

Heavy-duty construction with 8-inch rubber rear wheels. Convenient front handles, cable holders and plastic consumable box. For gas cylinders

no greater than 7 inches (178 mm) in diameter or 65 pounds (29.5 kg) in weight.



Dual Cylinder Rack Conversion Kit and Tool Holder 301454

Converts running gear/cylinder rack (301239) from a single cylinder cart to a dual cylinder cart. Top bracket holds a variety of tools including a welder, adjustable wrench, screwdrivers, chipping hammer, wire brush and filler rod.



Protective Cover 301262

Purchase the Millermatic 211 package (951603) and receive the Millermatic 211 and running gear/cylinder rack (301239) packaged together!

Consumables

For MDX™-100 MIG Gun

Miller® AccuLock™ MDX Consumables
Smaller consumables and components to access hard-to-reach weldments.

Contact Tips (10 per package)

T-M023	.023 in. (0.6 mm)
T-M030	.030 in. (0.8 mm)
T-M035	.035 in. (0.9 mm)
T-M045	.045 in. (1.2 mm)
T-M047	3/64 in. (1.2 mm)

Nozzles

NS-M1200B	Brass, 1/2 in. ID, flush
NS-M1200C	Copper, 1/2 in. ID, flush
NS-MFLX	Gasless nozzle

Diffuser D-M100

Monocoil Replacement Liners (10 ft.)

LM1A-10	.023/.025 in. (0.6 mm)
LMD2A-10	.030/.035 in. (0.8/0.9 mm)
LMD3A-10	.035/.045 in. (0.9/1.2 mm)

Note: Miller® FasTip™, M-Series and Bernard Centerfire™ diffusers and consumables are NOT compatible with MDX Series guns.

For Spoolmate™ 100 Spool Gun



Contact Tips (5 per package)

199730	.024 in. (0.6 mm)
186419	.030 in. (0.8 mm)
186406	.035 in. (0.9 mm)



Nozzle 186405

For Spoolmate™ 150 Spool Gun



Contact Tips (5 per package)

199387	.030 in. (0.8 mm)
199388	.035 in. (0.9 mm)

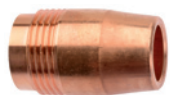

Nozzle 050622

For Both Spool Guns



Drive Roll (1) 186413
For .030/.035-inch (0.8/0.9 mm) wire.



Push Roll (1) 186414
For .030/.035-inch (0.8/0.9 mm) wire.

For Millermatic® 211



Quick Select™ Drive Roll 261157
For .024-inch (0.6 mm) or .030/.035-inch (0.8/0.9 mm) solid wire, and .030/.035-inch (0.8/0.9 mm) flux-cored wire.

V-Knurled Dual-Groove Drive Roll 202926
For .030/.035-inch (0.8/0.9 mm) or .045-inch (1.2 mm) flux-cored wire.

Ordering Information

Power Source and Options	Stock No.	Description	Qty.	Price
Millermatic® 211	907614	120/240 V, 50/60 Hz		
Millermatic® 211 with Running Gear/Cyl Rack	951603	Power source packaged with 301239 running gear/cylinder rack		
Guns				
MDX™-100 Gun	1770028	10 ft. (3 m), .030–.035 in (0.8–0.9 mm) wire		
Spoolmate™ 100 Spool Gun	300371	12 ft. (3.7 m). Includes custom carrying case		
Spoolmate™ 150 Spool Gun	301272	20 ft. (6.1 m)		
Accessories				
Running Gear/Cylinder Rack	301239			
Dual Cylinder Rack Conversion Kit and Tool Holder	301454			
Dual Cylinder Rack Cart	951770	Includes running gear/cylinder rack 301239 and dual cylinder rack conversion kit 301454. Must be assembled together		
Protective Cover	301262			
Material Thickness Gauge	229895			
Flow Gauge Regulator for Argon or AR/CO ₂ Mix	31-50-580-6	Replacement standard regulator		
Flow Gauge Regulator for CO ₂	31-50-320	Required if using 100 percent CO ₂ gas		
Flux-cored Wire				
Solid Wire				
Shielding Gas Cylinder				
Helmet/Gloves/Scratch Brush				
Consumables				
Contact Tips		See page 3		
Nozzles		See page 3		
Diffuser		See page 3		
Monocoil Replacement Liners		See page 3		
Drive Rolls		See page 3		

Date:

Total Quoted Price:

Distributed by:

