

Generator Power Application Guide

*Largest fuel capacity
means longest generator run
time! See page 2.*

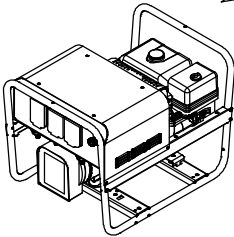

Blue Star[®] 145/185

- 4,500 or 6,000 watt models available
- 145 or 185 Amps of welding power

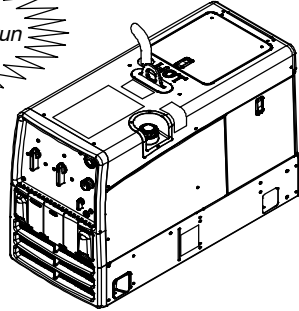

Bobcat[™] 225

- 11,000 watts of generator power
- 225 Amps of welding power

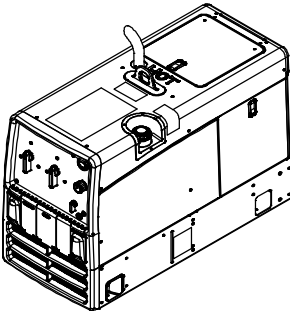

Bobcat[™] 250

- 11,000* watts of generator power (12,000 watts with EFI engine)
- 250 Amps of welding power
- Diesel and LP models also available

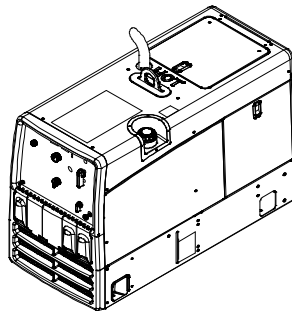

Trailblazer[®] 302 and 275 DC

- 11,000* watts of generator power (12,000 watts with EFI engine)
- 325 Amps of welding power
- Diesel and LP models also available

Why buy just a generator when you can buy a generator that also welds? Your best value for power is a Miller welder/AC generator because it is...

- Competitively priced compared to regular generators.
- Versatile—120 & 240 volts AC power *and* welding capabilities from the same machine.

Welder/AC Generator: Best Value For Power Needs

While you might not need a generator or welder for daily use, investing in a machine that performs both duties makes economic sense.

Like a “regular” generator, a Miller welder/AC generator provides 120 and 240 volts AC generator power. The 4,500 to 11,000 watt output capability of Miller’s mid-size generators is also suitable for home use.

What are the biggest benefits to a Miller welder/AC generator?

- At about the same cost as a “regular” generator, Miller generators are also excellent welding power sources capable of welding material up to 1/2 in. thick or more.
- Miller’s 3-year, True Blue® Total Parts warranty is longer than typical 1-year, generator warranties.
- Low Fuel Consumption – The Bobcat will run about 14 hours under a continuous load of 4000 watts of generator power. Weld at 150 Amps at 40% duty cycle for 16 hours!
- Accu-Rated™ Miller generators means they deliver the power that is promised. Patented self-cooling stator allows Miller generators to perform at 100% duty cycle, even in 104°F heat! And the Bobcat’s skewed rotor helps provide smoother power than other brands.



TRUE BLUE®
3YR. WARRANTY

Table Of Contents

1. Safety	1
2. How Much Generator Power Do You Need?	2
3. Wattage Reference Guide	3
4. Frequently Asked Questions	4
5. Selecting Auxiliary Equipment	5
6. Grounding Generator To Truck Or Trailer Frame	6
7. Grounding When Supplying Building Systems	6
8. Power Required To Start A Motor	7
9. How Much Power Can The Generator Supply?	7
10. Typical Connections To Supply Standby Power	8
11. Wiring Optional 240 Volt, Single-Phase Plug (NEMA 14-50P) ...	9
12. Selecting Extension Cord (Use Shortest Cord Possible)	10

- See Owner's Manual for meaning of safety symbols and complete safety instructions.
- For more detailed information, read Owner's Manual, or call the Factory Applications Engineering Department at (920) 735-4265.



WARNING

GENERATOR POWER can be hazardous.

- Read and follow all labels and the Owner's Manual carefully.
- Only qualified persons are to install, operate, or service this unit according to all applicable codes and safety practices.
- Keep children away.
- Wearers of pacemakers and other Implanted Medical Devices should keep away.

1. Safety



WARNING



ELECTRIC SHOCK can kill.

- Do not touch live electrical parts.
- Use only grounded or double insulated equipment.
- Stop engine before making internal inspection or reconnection.
- Properly install and ground generator according to its Owner's Manual and all applicable national, state, and local codes.
- Connect equipment grounding terminal to a proper earth ground.
- Do not connect to any electrical distribution system normally supplied by utility power unless a proper transfer switch and grounding procedure are employed.
- Have only qualified persons make electrical connections.
- Use all code-required methods for shock and overcurrent protection.



Using a generator indoors CAN KILL YOU IN MINUTES.

- Generator exhaust contains carbon monoxide. This is a poison you cannot see or smell.
- NEVER use inside a home or garage, EVEN IF doors and windows are open.
- Only use OUTSIDE and far away from windows, doors, and vents.



MOVING PARTS can cause serious injury.

- Keep away from moving parts such as fans, belts, and rotors.
- Keep all doors, panels, covers, and guards closed and securely in place.



ELECTRIC SPARKS can cause fire.

- If using generator power only and not welding, disconnect both welding cables to prevent live electrode from causing electric shock and fire hazards.
- Watch for fire.
- Keep a fire extinguisher nearby, and know how to use it.

The weld output terminals are electrically energized when the engine is running and the contactor, if applicable, is energized.



LOW VOLTAGE AND FREQUENCY can damage electrical equipment.

- Turn off or unplug all electrical equipment connected to generator power receptacles before starting or stopping the engine.

When starting or stopping, the engine has low speed which causes low voltage and frequency.

2. How Much Generator Power Do You Need?

EXAMPLE WORKSHEET

TOOL OR APPLIANCE	Column A	Column B	Column C
	STARTING WATTS	RUNNING WATTS	ADDITIONAL STARTING WATTS
1. Refrigerator	2,200	700	1,500
2. Sump Pump	1,300	800	500
3. Table Saw	6,300	1,800	4,500
4.			
5.			
6.			
7.			

TOTAL RUNNING WATTS =

HIGHEST
ADDITIONAL
STARTING WATTS

+
TOTAL RUNNING WATTS

=
TOTAL WATTS NEEDED

With this example you need a generator that produces at least 3,300 total running watts and 7,800 total watts.

Use this easy reference to determine the generator size you need. To select a generator with enough power output in watts, add the watts for the items you want to simultaneously run. Tools and appliances with induction motors may require 3 – 7 times the listed wattage when starting. All data listed is approximate—check your tool/appliance for specific wattage requirements. Your actual requirements will vary (see Sections 4 and 7).

This worksheet will focus on determining your starting and running watt needs.

Amount of generator power you need depends on your power requirements. Generally, a higher-wattage generator lets you power more items at once.

1 Select the items you wish to power at the same time. Using the chart in Section 3, fill in the starting watts (Column A) and running watts (Column B) requirements.

2 Add all the items in the RUNNING WATTS column (Column B) to determine total running watts. Enter the total in the TOTAL RUNNING WATTS boxes.

3 Subtract RUNNING WATTS (Column B) from STARTING WATTS (Column A). Enter the results in the ADDITIONAL STARTING WATTS column (Column C). Select the ONE INDIVIDUAL ITEM with the highest number of ADDITIONAL STARTING WATTS. Take this ONE NUMBER, add it to your TOTAL RUNNING WATTS, and enter the total in the TOTAL WATTS NEEDED box.

EXAMPLE WORKSHEET

TOOL OR APPLIANCE	Column A	Column B	Column C
	STARTING WATTS	RUNNING WATTS	ADDITIONAL STARTING WATTS
1.		—	=
2.			
3.			
4.			
5.			
6.			
7.			

TOTAL RUNNING WATTS =

HIGHEST
ADDITIONAL
STARTING WATTS
(COLUMN C)

+
TOTAL RUNNING WATTS

=
TOTAL WATTS NEEDED

I need a generator that produces at least _____ total running watts and _____ total watts.

3. Wattage Reference Guide

HOUSEHOLD		
Appliances	Starting Watts	Running Watts
Dishwasher (cool dry)	1,400	700
Electric Range (6-inch element)	0	1,500
Microwave Oven (625 watts)	800	625
Refrigerator or Freezer	2,200	700
Automatic Washer	2,300	1,150
Clothes Dryer (gas / electric)	1,800 / 1,800	700 / 5,750
Garage Door Opener (1/4 hp)	1,100	550
Furnace Fan, Gas or Fuel Oil (1/4 hp)	1,000	600
Well Pump (1/3 hp)	1,400	750
Sump Pump (1/3 hp)	1,300	800
Central Air Conditioner (20,000 BTU)	3,300	2,500
CONTRACTOR TOOLS		
Tool	Starting Watts	Running Watts
Hand Drill (1/2 in)	600	600
Circular Saw (8-1/4 in)	1,400	1,400
Table Saw (10 in)	6,300	1,800
Band Saw (14 in)	2,500	1,100
Air Compressor (1-1/2 hp)	8,200	2,200
Electric Chain Saw (2 hp, 14 in)	1,100	1,100
Spectrum® 625 Plasma Cutter (30 amp, 230 volts, 1/2 in cut)	3,500	3,500
Millermatic® 212 MIG Welder (30–210 amps, 230 volt)	6,500	6,500
Flood Lights (vapor)	1,250	1,000
Submersible Pump (400 gph)	600	200
Centrifugal Pump (900 gph)	900	500
High Pressure Washer (1 hp)	6,100	1,600
Wet & Dry VAC (1.7 hp)	900	900
FARM EQUIPMENT		
Machine	Starting Watts	Running Watts
Barn Cleaner (5 HP)	11,600	3,000
Silo Unloader	12,200	4,300
Portable Conveyer (1/2 hp)	3,400	1,000
Milker, Vacuum Pump (2 hp)	10,500	2,800
Farm Duty Motors—Conveyers, Feed Augers, Air Compressors, Etc. (1-1/2 hp)	8,200	2,200
Washer, 2 gal/min (550 PSI)	4,500	1,400
INDUSTRIAL MOTORS		
Motor	Starting Watts	Running Watts
Split Phase (1/2 hp)	3,175	875
Capacitor Start, Induction Run (1-1/2 hp)	8,200	2,200
Capacitor Start, Capacitor Run (1-1/2 hp)	8,100	2,000
Fan (1/2 hp)	3,500	1,100

4. Frequently Asked Questions

How many watts does it take to power basic items in an average size house?

In a typical home, essential items use about 4000 – 6000 watts of power. Select a generator that can provide the necessary power while maintaining rated voltage. Low voltage may damage appliances and other equipment (see power curve example below).

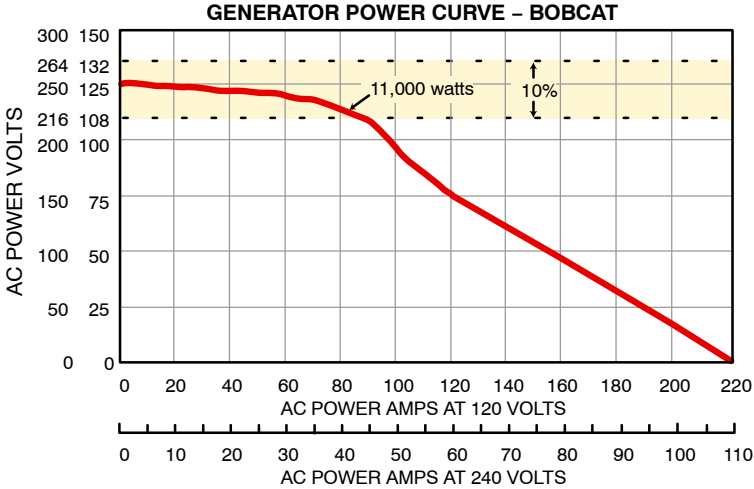

Tools and motors are designed to operate within 10% of 120/240 VAC. The Bobcat's power generator provides strong power while keeping the voltage within 10% of 120/240 VAC. This increases tool/motor performance and life.

What is the difference between running watts and starting watts?

Running watts are the continuous watts needed to keep items running. Starting watts are extra watts needed for two to three seconds to start motor-driven products like a refrigerator or circular saw.

Why is only one additional starting watt item used to calculate your total watt requirement?

Unlike running watts, starting watts are only needed during the first few seconds of operation. In most cases, only one item will start or cycle at the same time, therefore this is the most accurate estimate.

What if I can't determine the running or the starting watt requirement for a tool or appliance?

If the running watts are not on the tool or appliance, you may estimate using the following equation: **WATTS = VOLTS x AMPS**.

Only motor-driven items will have an additional starting requirement. The additional starting watts required in most cases may be estimated at 3 – 7 times the rated running watts.



Resistive Load

(requires constant amount of power)

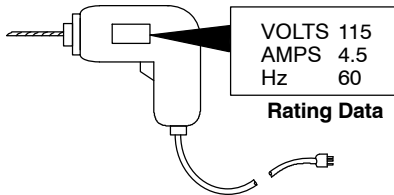

Non-Resistive Load

(Motors require as much as 3 – 7 times more power when starting than when running)

S-0623

5. Selecting Generator Equipment

1 Generator Power Receptacles – Neutral Bonded To Frame

2 3-Prong Plug From Case Grounded Equipment

3 2-Prong Plug From Double Insulated Equipment

Be sure equipment has double insulated symbol and/or wording on it.

Do not use 2-prong plug unless equipment is double insulated.

Ref. ST-159 730 / ST-800 577

6. Grounding Generator To Truck Or Trailer Frame

Always ground generator frame to vehicle frame to prevent electric shock and static electricity hazards.

Also see AWS Safety & Health Fact Sheet No. 29, Grounding of Portable And Vehicle Mounted Welding Generators.

1 Metal Vehicle Frame

2 Equipment Grounding Terminal

3 Grounding Cable

Use #8 AWG or larger insulated copper wire.

Use GFCI protection when operating auxiliary equipment. If unit does not have GFCI receptacles, use GFCI-protected extension cord.

Electrically bond generator frame to vehicle frame by metal-to-metal contact.

S-0854

7. Grounding When Supplying Building Systems





1 Equipment Grounding Terminal

2 Grounding Cable

Use #8 AWG or larger insulated copper wire.

3 Ground Device

 Use ground device as stated in electrical codes.

 **Ground generator to system earth ground if supplying power to a premises (home, shop, farm) wiring system.**

 **Also see AWS Safety & Health Fact Sheet No. 29, Grounding of Portable And Vehicle Mounted Welding Generators.**

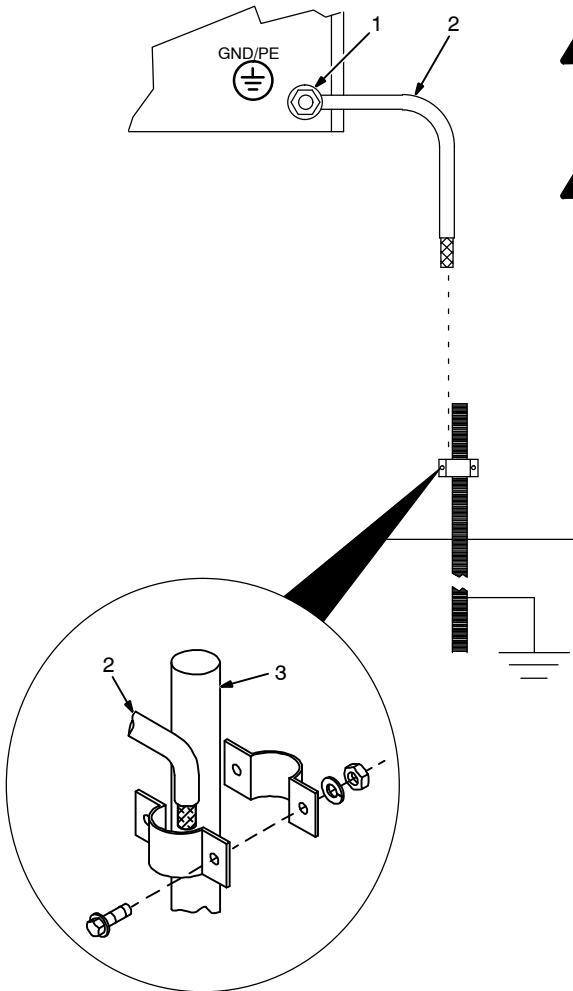

ST-800 576-B

8. Power Required To Start A Motor

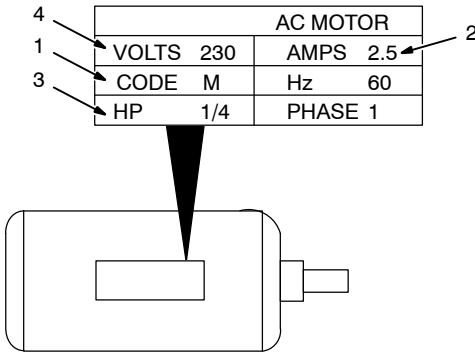

- 1 Motor Start Code
- 2 Running Amperage
- 3 Motor HP
- 4 Motor Voltage

To find starting amperage:

Step 1: Find code and use table to find kVA/HP. If code is not listed, multiply running amperage by six to find starting amperage.

Step 2: Find Motor HP and Volts.

Step 3: Determine starting amperage (see example).

Welding generator amperage output must be at least twice the motor's running amperage.

Single-Phase Induction Motor Starting Requirements

Motor Start Code	G	H	J	K	L	M	N	P
KVA/HP	6.3	7.1	8.0	9.0	10.0	11.2	12.5	14.0

$$\frac{\text{KVA/HP} \times \text{HP} \times 1000}{\text{VOLTS}} = \text{STARTING AMPERAGE}$$

EXAMPLE: Calculate the starting amperage required for a 230 V, 1/4 HP motor with a motor start code of M.

Volts = 230 HP = 1/4 Using Table, Code M results in kVA/HP = 11.2

$$\frac{11.2 \times 1/4 \times 1000}{230} = 12.2 \text{ A} \quad \text{Starting the motor requires 12.2 amperes.}$$

S-0624

9. How Much Power Can The Generator Supply?

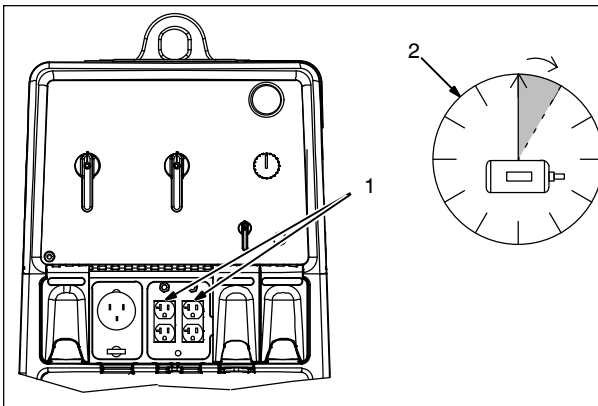

- 1 Limit Load To 90% Of Generator Output

Always start non-resistive (motor) loads in order from largest to smallest, and add resistive loads last.

- 2 5 Second Rule

If motor does not start within 5 seconds, turn off power to prevent motor damage. Motor requires more power than generator can supply.

803 636 / S-0625

10. Typical Connections To Supply Standby Power



⚠ Properly install, ground, and operate this equipment according to its Owner's Manual and national, state, and local codes.

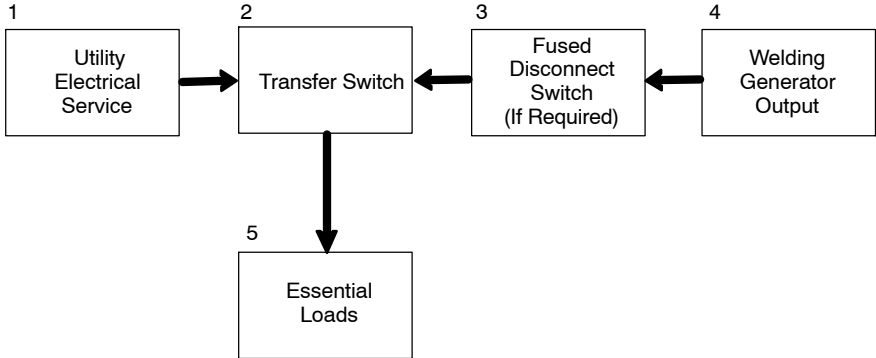

⚠ Have only qualified persons perform these connections according to all applicable codes and safety practices.

⚠ Properly install, ground, and operate this equipment according to its Owner's Manual and national, state, and local codes.

☞ Customer-supplied equipment is required if generator will supply standby power during emergencies or power outages.

1 Utility Electrical Service

2 Transfer Switch (Double-Throw)

Switch transfers the electrical load from electric utility service to the generator. Transfer load back to electric utility when service is restored.

Install correct switch (customer-supplied). Switch rating must be same as or greater than the branch overcurrent protection.

3 Fused Disconnect Switch

Install correct switch (customer-supplied) if required by electrical code.

4 Welding Generator Output

Generator output voltage and wiring must be consistent with regular (utility) system voltage and wiring.

Connect generator with temporary or permanent wiring suitable for the installation.

Turn off or unplug all equipment connected to generator before starting or stopping engine. When starting or stopping, the engine has low speed which causes low voltage and frequency.

5 Essential Loads

Generator output may not meet the electrical requirements of the premises. If generator does not produce enough output to meet all requirements, connect only essential loads (pumps, freezers, heaters, etc. – See Section 2).

11. Wiring Optional 240 Volt, Single-Phase Plug (NEMA 14-50P)



Tools Needed:

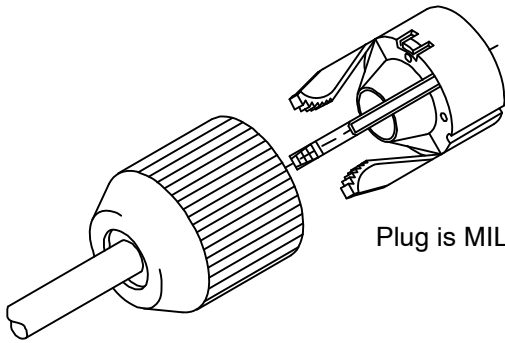
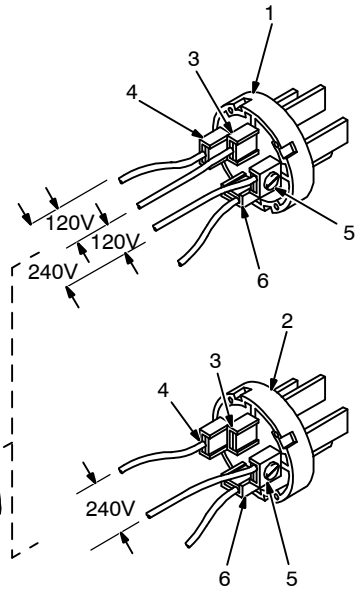
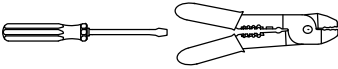

Plug is MILLER Part No. 119 172

Plug1 7/99 – 120 813-D

The plug can be wired for a 240 V, 2-wire load or a 120/240V, 3-wire load. See circuit diagram in Owner's Manual.

1 Plug Wired for 120/240 V, 3-Wire Load

When wired for 120 V loads, each duplex receptacle shares a load with one half of 240 V receptacle.

- 2 Plug Wired for 240 V, 2-Wire Load
- 3 Neutral (Silver) Terminal
- 4 Load 1 (Brass) Terminal
- 5 Load 2 (Brass) Terminal
- 6 Ground (Green) Terminal

Strip cord jacket back enough to separate conductors.

Strip conductors enough to make good contact with plug terminals. Make plug connections and reinstall outer shell and cord grip.

Tighten assembly screws onto shell. Do not overtighten.

12. Selecting Extension Cord (Use Shortest Cord Possible)



Cord Lengths For 120 Volt Loads



Use GFCI protection if operating auxiliary equipment. If unit does not have GFCI receptacles, use GFCI-protected extension cord.

Current In Amperes	Load In Watts	Maximum Allowable Cord Length In Feet (Meters) For Conductor Size (AWG)*					
		4	6	8	10	12	14
5	600			350 (106)	225 (68)	137 (42)	100 (30)
7	840		400 (122)	250 (76)	150 (46)	100 (30)	62 (19)
10	1200	400 (122)	275 (84)	175 (53)	112 (34)	62 (19)	50 (15)
15	1800	300 (91)	175 (53)	112 (34)	75 (23)	37 (11)	30 (9)
20	2400	225 (68)	137 (42)	87 (26)	50 (15)	30 (9)	
25	3000	175 (53)	112 (34)	62 (19)	37 (11)		
30	3600	150 (46)	87 (26)	50 (15)	37 (11)		
35	4200	125 (38)	75 (23)	50 (15)			
40	4800	112 (34)	62 (19)	37 (11)			
45	5400	100 (30)	62 (19)				
50	6000	87 (26)	50 (15)				

*Conductor size is based on maximum 2% voltage drop

Cord Lengths For 120 Volt Loads



Use GFCI protection if operating auxiliary equipment. If unit does not have GFCI receptacles, use GFCI-protected extension cord.

Current In Amperes	Load In Watts	Maximum Allowable Cord Length In Feet (Meters) For Conductor Size (AWG)*					
		4	6	8	10	12	14
5	1200			700 (213)	450 (137)	225 (84)	200 (61)
7	1680		800 (244)	500 (152)	300 (91)	200 (61)	125 (38)
10	2400	800 (244)	550 (168)	350 (107)	225 (69)	125 (38)	100 (31)
15	3600	600 (183)	350 (107)	225 (69)	150 (46)	75 (23)	60 (18)
20	4800	450 (137)	275 (84)	175 (53)	100 (31)	60 (18)	
25	6000	350 (107)	225 (69)	125 (38)	75 (23)		
30	7000	300 (91)	175 (53)	100 (31)	75 (23)		
35	8400	250 (76)	150 (46)	100 (31)			
40	9600	225 (69)	125 (38)	75 (23)			
45	10,800	200 (61)	125 (38)				
50	12,000	175 (53)	100 (31)				

*Conductor size is based on maximum 2% voltage drop

Miller Electric Mfg. Co.

An Illinois Tool Works Company
1635 West Spencer Street
Appleton, WI 54914 USA

International Headquarters-USA

USA Phone: 920-735-4505 Auto-Attended
USA & Canada FAX: 920-735-4134
International FAX: 920-735-4125

Web Site-www.MillerWelds.com

