

# Spectrum® 375 X-TREME™

Issued April 2008 • Index No. PC/9.2

**Air Plasma  
Cutting** 

## Quick Specs

### Industrial Applications

Maintenance  
Light Construction  
Prototyping  
Body Shops  
Fabrication  
HVAC Ductwork

### Process

Air Plasma Cutting

### Rated Output

27 A at 92 VDC,  
35% Duty Cycle

### Cutting Capability

Rated: 3/8 in (9.5 mm)  
Sever: 5/8 in (15.9 mm)

### Weight

With torch: 18 lb (8.2 kg)

### Required Input Pressure/Flow

4.5 SCFM (128 L/min) at  
90 PSI MIN (621 kPa)  
120 PSI MAX (828 kPa)

## The Power of Blue.®

**X-TREME Versatility** — Auto-Line™ provides state-of-the-art flexibility to the end user. The Auto-Line circuitry automatically connects to 115–230 VAC, single-phase power, 50/60 Hz, without removing the covers to relink the power source. No longer is there a concern if you have the correct machine for the shop or job site.

**X-TREME Protection** — X-CASE™ provides ultimate protection during transport and storage. Additional space ideal for MVP plugs, consumable box, as well as gloves, eye protection, etc.

**X-TREME Portability** — Portable in the shop or at the job site — at 18 lb the shoulder strap allows the end user to easily move from location to location.

**Can be powered by any Miller engine drive** with generator power (e.g. Bobcat™) or equivalent competitive equipment. See page 3 for engine drive compatibility and recommended settings.

**LED indicators for pressure, power, cup and temperature** allow faster troubleshooting, eliminating unnecessary downtime.

Includes **heavy-duty clamp**.

**Ergonomic design ICE-27T torch** with increased comfort, safety trigger, and improved swirl ring and cup.

**Factory pre-set air**—no need to adjust the air pressure! The unit automatically regulates the air pressure to the torch.



Spectrum Plasma Cutters offer reliability and performance that others can't match! See more at [MillerWelds.com/reliable](http://MillerWelds.com/reliable)

### Comes Complete With:

- ICE-27T hand-held torch with 12 ft (3.7 m) cable
- Heavy-duty work clamp with 12 ft (3.7 m) cable
- X-CASE™ provides protection in transport and storage
- MVP™ plugs 5-15P (115 V, 15 A), 6-50P (230 V, 50 A)
- Consumables box with 3 electrodes, 3 tips and air fitting
- 10 ft (3 m) MVP power cord



**LVC™ line voltage compensation** provides peak performance power under variable conditions (power fluctuations up to ±15%) for steady cuts and cleaner ending cuts.

**Gas/air filter/regulator inside the power source** provides added protection during transportation. Standard air connection on back panel for easy gas or air hookup.

**Starts without high-frequency** so it will not interfere with controls or computers.



Miller's exclusive **multi-voltage plug (MVP™)** allows connection to 115 or 230 V receptacles without tools—choose the plug that fits the receptacle and connect it to the power cord.

**TRUE BLUE®**  
3YR WARRANTY

Power source is warranted for 3 years, parts and labor.  
ICE torch is warranted for 1 year, parts and labor.

MADE IN **USA**  
APPLETON, WI **USA**



**Miller Electric Mfg. Co.**  
An Illinois Tool Works Company  
1635 West Spencer Street  
Appleton, WI 54914 USA

**International Headquarters**  
Phone: 920-735-4505  
USA FAX: 920-735-4134  
Canadian FAX: 920-735-4169  
International FAX: 920-735-4125

**Web Site**  
[www.MillerWelds.com](http://www.MillerWelds.com)



# Specifications (Subject to change without notice.)



Input Power	Rated Output	Amps Input at Rated Output, 50/60 Hz, 1-Phase	KVA	KW	Plasma Gas	Dimensions	Weight with Torch
240 V	27 A at 92 VDC, 35% duty cycle	13.9	3.4	3.2	Air or Nitrogen only	H: 9 in (229 mm) W: 5-1/2 in (140 mm) D: 13-1/4 in (337 mm)	Net: 18 lb (8.2 kg) Ship: 23 lb (10.5 kg)
120 V (20 A)	27 A at 92 VDC, 20% duty cycle	28.8	3.4	3.2			
120 V (15 A)	20 A at 88 VDC, 35% duty cycle	20.6	2.5	2.3			

\*Recommended 30 A branch circuit for maximum performance. Performance on 20 A branch service may be limited due to breaker/line fuse. Reducing unit output amperage will minimize nuisance breaker/line fuse tripping.

## Mild Steel Cutting Capability (Thickness to scale.)

**Cutting at 27 Amps** (115 V, 20 A service with 5-20P MVP or 230 V 6-50P MVP)



1/4 in (6.4 mm) at 24 IPM



3/8 in (9.5 mm) at 14 IPM

Note: Recommended maximum piercing capacity for hand-held applications is 3/16 in (4.8 mm). Maximum Sever cut of 5/8 in (15.9 mm) at 5 IPM.

For aluminum and other metals with high thermal conductivity, cutting capabilities will be derated as much as 30%.

Maximum Cutting Speeds at 27 Amps Output

Thickness	Approximate Travel Speeds*
16 ga (1.5 mm)	188 IPM (4775 mm/min)
3/16 in (4.8 mm)	40 IPM (1016 mm/min)
1/4 in (6.4 mm)	24 IPM (610 mm/min)
3/8 in (9.5 mm)	14 IPM (256 mm/min)
1/2 in (12.7 mm)	6 IPM (152 mm/min)

\*Travel speeds are approximately 80% of maximum.

**Cutting at 20 Amps** (115 V, 15 A service with 5-15P MVP)



1/4 in (6.4 mm) at 18 IPM



5/16 in (8 mm) at 10 IPM

Note: Recommended maximum piercing capacity for hand-held applications is 1/8 in (3.2 mm). Maximum Sever cut of 3/8 in (10 mm) at 3 IPM.

For aluminum and other metals with high thermal conductivity, cutting capabilities will be derated as much as 30%.

Maximum Cutting Speeds at 20 Amps Output

Thickness	Approximate Travel Speeds*
16 ga (1.5 mm)	162 IPM (4115 mm/min)
3/16 in (4.8 mm)	26 IPM (660 mm/min)
1/4 in (6.4 mm)	18 IPM (457 mm/min)
5/16 in (8 mm)	10 IPM (254 mm/min)
3/8 in (9.5 mm)	7 IPM (178 mm/min)

\*Travel speeds are approximately 80% of maximum.

**Rated cut capacity is based on traveling approximately 10 inches per minute to achieve a steady, precise cut. This is the key rating that should meet or exceed your typical cutting thickness requirements.**

## Control Panel

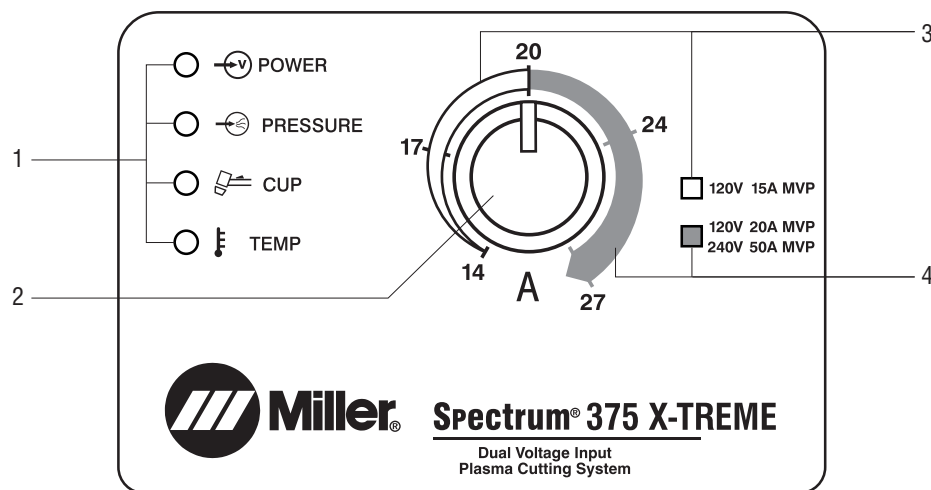

1. Status and Troubleshooting Lights
2. Output Control
3. Range for 120 V, 15 A, 5-15 P, MVP™
4. Range for 120 V, 20 A, 5-20 P, MVP™ or 230 V, 50 A, 6-50 P, MVP™

## Engine Drive Compatibility

Equipment	Generator Power	Steel Quality Cut (Approximate)	Spectrum Output Amp Setting
Bobcat™ 250, Trailblazer® 302 & 275 DC	11 kW	3/8 in	27 A, 240 V, full KVA plug
Bobcat™ 225	10.5 kW	3/8 in	27 A, 240 V, full KVA plug
Miller Legend® 302	5 kW	3/8 in	27 A, 240 V, full KVA plug
PipePro® 304, PRO 300	12 kW	3/8 in	27 A, 240 V, full KVA plug
Big 40® CC/CV	15 kW (optional)	3/8 in	27 A, 240 V, full KVA plug
Big Blue® 500 CC/CV	20 kW (optional)	3/8 in	27 A, 240 V, full KVA plug

## Genuine Miller Accessories



**X-CASE™ #300 184**  
Sturdy case provides ultimate protection for transport and storage. Also features convenient

top carrying handle and side recessed hand grips. Store the Spectrum® 375 X-TREME™, accessories and gear in this generous case to be ready to go at any time. Dimensions: 13 in H x 10-1/2 in W x 30-5/8 in D (330 x 267 x 778 mm).



Female Receptacle



**Adapter Cord, Full KVA #300 158** Field NEMA 14-50P to NEMA 6-50R. Adapts engine drive 120/240 V plug to Spectrum® 240 V plug.

### Miller Service Parts Accessories

*The following accessories must be ordered from Miller Service Parts.*



**Cable Management System #228 941**

Controls cables while in transit.

Adjustable nylon web straps with quick-release clips and Velcro® straps keep cables bundled together. System quickly screws onto Spectrum® 375 X-TREME™ case.



**ICE-27T Consumable Kit #222 939**

Consumable kit includes 5 electrodes, 5 tips, 1 swirl ring, 1 retaining cup, 1 o-ring and silicone grease.



**Plasma Standoff Roller Guide #194 883**

Helps maintain recommended

standoff distance to maximize cutting performance and improve tip life.



**Plasma Circle-Cutting Guide #195 981**

Cut straight lines or circles up to 12 inch diameter with ease.



**Suction/Magnetic Pivot Base #195 979**

Add this to your cutting guide for convenient attachment to all flat surfaces. The extended arm accommodates holes up to 30 inch diameter.



**In-Line Air Filter Kit #228 926**

Mounts to the back of the Spectrum® 375 X-TREME™, 375, 625, 2050, 1000, 1251. Includes male and female

1/4 in NPT quick disconnect fittings and hose for easy on/off connection. The replaceable filter element filters to .85 microns.

**In-Line Air Filter Replacement Element #228 928**

Includes 1 replacement filter for in-line filter #228 926.



**MIG Gloves**

#227 821 Small  
#227 822 Medium  
#227 823 Large  
#227 824 X-Large

*For medium-duty MIG welding and metalworking*

*tasks. Combination of durable top grain cowhide palm and abrasion-resistant pig split back sewn with Kevlar® thread.*



**Metalworker Gloves**

#227 817 Small  
#227 818 Medium  
#227 819 Large  
#227 820 X-Large

*Designed for the daily*

*demands of the metalworker and material handler. Padded, goatskin palm with textured G-Grip™ patch for excellent grip. Neoprene wrist with Velcro® closure for improved fit. NOT intended for use while welding.*

### MVP™ Adapter Plugs

*Order from Miller Service Parts.*



**#219 258**

For Power Cable 6-50P (230 V/50 A).  
Included with machine.



**#219 261**

For Power Cable 5-15P (115 V/15 A).  
Included with machine.



**#219 259**

For Power Cable 5-20P (115 V/20 A). Optional.

# Replacement Torch and Consumables

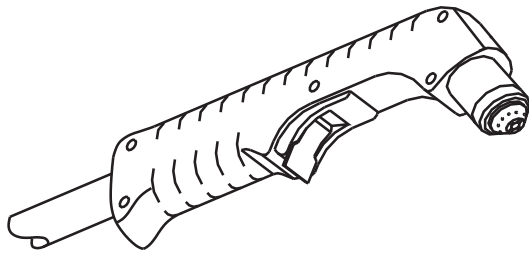

ICE-27T Hand-Held 12 ft (3.7 m) Torch #225 615

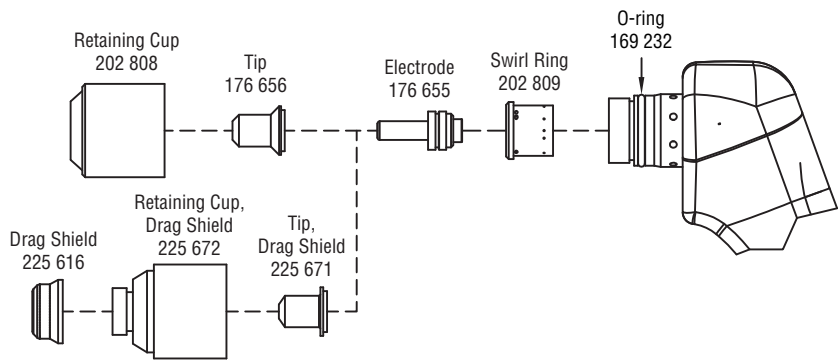

## Ordering Information

Power Source and Options	Stock No.	Description	Qty.	Price
Spectrum® 375 X-TREME™ with X-CASE™	#907 339	115–230 VAC, 50/60 Hz, with ICE-27T 12 ft (3.7 m) hand-held torch and X-CASE™		
Spectrum® 375 X-TREME™ (only)	#907 303	115–230 VAC, 50/60 Hz, with ICE-27T 12 ft (3.7 m) hand-held torch		
X-CASE™ (only)	#300 184	Carrying case for Spectrum® 375 X-TREME™		
<b>Replacement Torch and Consumables</b>				
ICE-27T Hand-Held Torch	#225 615	12 ft (3.7 m). <i>Order from Miller Service Parts</i>		
Consumables		See above. <i>Order from Miller Service Parts</i>		
<b>Accessories</b>				
Adapter Cord, Full KVA	#300 158	Adapts engine drive 120/240 V plug to Spectrum® 240 V plug		
Cable Management System	#228 941	Field. <i>Order from Miller Service Parts</i>		
ICE-27T Consumables Kit	#222 939	Includes 5 electrodes, 5 tips, 1 swirl ring, 1 retaining cup, 1 o-ring and silicone grease. <i>Order from Miller Service Parts</i>		
Silicone Grease	#169 231	<i>Order from Miller Service Parts</i>		
Plasma Standoff Roller Guide	#194 883	<i>Order from Miller Service Parts</i>		
Plasma Circle-Cutting Guide	#195 981	<i>Order from Miller Service Parts</i>		
Suction/Magnetic Pivot Base	#195 979	<i>Order from Miller Service Parts</i>		
In-Line Air Filter Kit	#228 926	<i>Order from Miller Service Parts</i>		
In-Line Air Filter Replacement Element	#228 928	<i>Order from Miller Service Parts</i>		
MIG Gloves		See page 3. <i>Order from Miller Service Parts</i>		
Metalworker Gloves		See page 3. <i>Order from Miller Service Parts</i>		
MVP™ Adapter Plugs		See page 3. <i>Order from Miller Service Parts</i>		

Date:

Total Quoted Price:

 Certified by Canadian Standards Association to both Canadian and U.S. standards.



Distributed by: