

Millermatic® Reach Wire Feeder

Issued Sept. 2009 • Index No. M/6.8



Quick Specs

Applications

Metal Fabrication
Maintenance and Repair
Farm/Home

Processes

MIG (GMAW)
Flux Cored (FCAW)
Pulsed MIG (GMAW-P)*
** with Millermatic 350P model only*

Input Power 14–32 Operating Voltage
100 VDC/Maximum OCV

Wire Feed Speed 50–700 IPM

Weight 29 lb (13.2 kg) with 6 ft cable
48 lb (21.8 kg) with 25 ft cable

The Power of Blue.®

Extend your Millermatic work area up to 40 ft!
No more moving the machine and pulling primary power cables around the shop.

Use as a dual feeder option! Keep one wire in the machine and a different wire in the feeder. No more downtime changing spools and drive rolls.

Auto-Gun Detect™ — when connected to a Millermatic 252 or 350P, simply pull the trigger on either gun and the Millermatic machine will recall both voltage & wire feed speed of the active gun.

Synergic Pulse Capability when connected to Millermatic 350P. Remotely change weld output by simply adjusting wire feed speed setting at the feeder.

Patent-pending Hybrid Technology — connects to Millermatic 10-pin connector and welding output circuit.

Works with any Miller-compatible MIG gun
(MIG gun sold separately).



Compatible with the following Millermatic models:

Millermatic 212 Auto-Set™
Millermatic 251
Millermatic 252
Millermatic 350P

Polypropylene case with built-in slide rails gives you the ability to easily change wire when in vertical position.

Double-filtered gas valve helps keep dirt from clogging and affecting gas flow.

Comes standard with .035/.045 reversible drive roll.

Wire Feeder only. Must be connected to a Millermatic Power Source

Specifications (Subject to change without notice.)

CV DC (Use with selected Millermatic DC Power Sources.)

Input Power	Input Welding Circuit Rating	Wire Speed	Wire Diameter Range	Maximum Wire Spool Capacity	Dimensions	Net Weight
Open-Circuit Arc Voltage 14–100 VDC	300 A at 60% Duty Cycle	50–700 IPM (1.3–17.8 m/min) dependent on arc voltage	.023 – 3/64 in (0.6 – 1.2 mm)	45 lb (20.4 kg) 12 in (304 mm)	H: 15-1/2 in (394 mm) W: 9 in (229 mm) D: 21 in (533 mm)	29 lb (13.2 kg) with 6 ft cable 48 lb (21.8 kg) with 25 ft cable



Wire feeder is warranted for 3 years, parts and labor.

MADE IN USA
APPLETON, WI



Miller Electric Mfg. Co.
An Illinois Tool Works Company
1635 West Spencer Street
Appleton, WI 54914 USA

Equipment Sales US and Canada
Phone: 866-931-9730
FAX: 800-637-2315
International Phone: 920-735-4554
International FAX: 920-735-4125

Web Site
www.MillerWelds.com



Control Panels

Front Control Panel

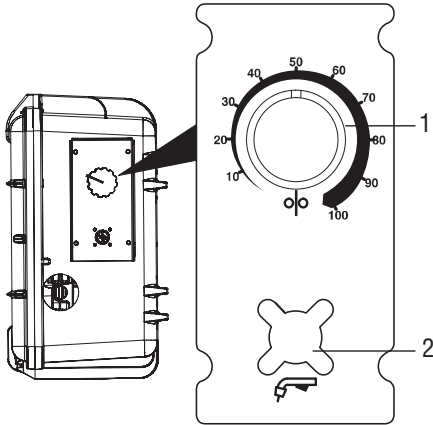

1. Wire Speed Control
2. Trigger Receptacle

Internal Side View

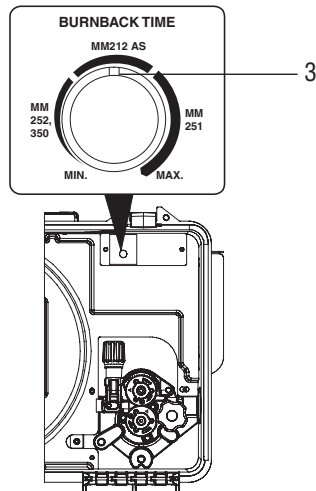

3. Burnback Time Control

Drive Roll Kits (Order from Miller Service Parts.)

Select drive roll kits from chart below according to type and wire size being used. Drive roll kits include 2 drive rolls, the necessary guides and feature an anti-wear sleeve for inlet guide.

Wire size	"V" groove for hard wire	"U" groove for soft wire or soft-shelled cored wires	"V" knurled for hard-shelled cored wires
.023/.025 in (0.6 mm)	#087 131	—	—
.030 in (0.8 mm)	#079 594	—	—
.035 in (0.9 mm)	#079 595	—	#079 606
.045 in (1.1/1.2 mm)	#079 596	—	#079 607
.047 in (1.19 mm)	—	#079 599	—
.052 in (1.3/1.4 mm)	#079 597	—	#079 608

Comes standard with .035/.045 reversible drive rolls.

Genuine Miller Accessories



Small Running Gear #300 425
Durable construction. Maximum weight 75 lb (34 kg).



Running Gear #770 187
Heavy-duty construction. Convenient handle on front with cable holders. Maximum weight 100 lb (45 kg).

Argon/Mixed Gas Regulator and Gas Hose #195 050

Ordering Information

Equipment and Options	Stock No.	Description	Qty.	Price
Millermatic® Reach Wire Feeder (MIG gun sold separately)	#907 437	Includes 6 ft feeder weld cable, 10-pin interconnect cable, feeder power lead, and 12 ft gas hose		
	#907 438	Includes 25 ft feeder weld cable, 10-pin interconnect cable, feeder power lead, and 31 ft gas hose		
MIG Guns				
M-25	#169 596	12 ft (3.7 m), .023–.035 in (0.6–0.9 mm)		
	#169 598	15 ft (4.6 m), .023–.035 in (0.6–0.9 mm)		
Roughneck® C-Series		See Lit. Index No. AY/17.0		
Bernard® Q300		See Welding Components and Parts Guide		
Bernard® Q400 Aluminum Gun/Drive Roll Kit	Q40128RAL1	12 ft (3.7 m), 400 A, .047 in (1.2 mm) with .047 in (1.2 mm) U-groove drive rolls (#079 599)		
Accessories				
Running Gear	#770 187			
Small Running Gear	#300 425			
Argon/Mixed Gas Regulator and Gas Hose	#195 050			

Date:

Total Quoted Price:



Distributed by: