

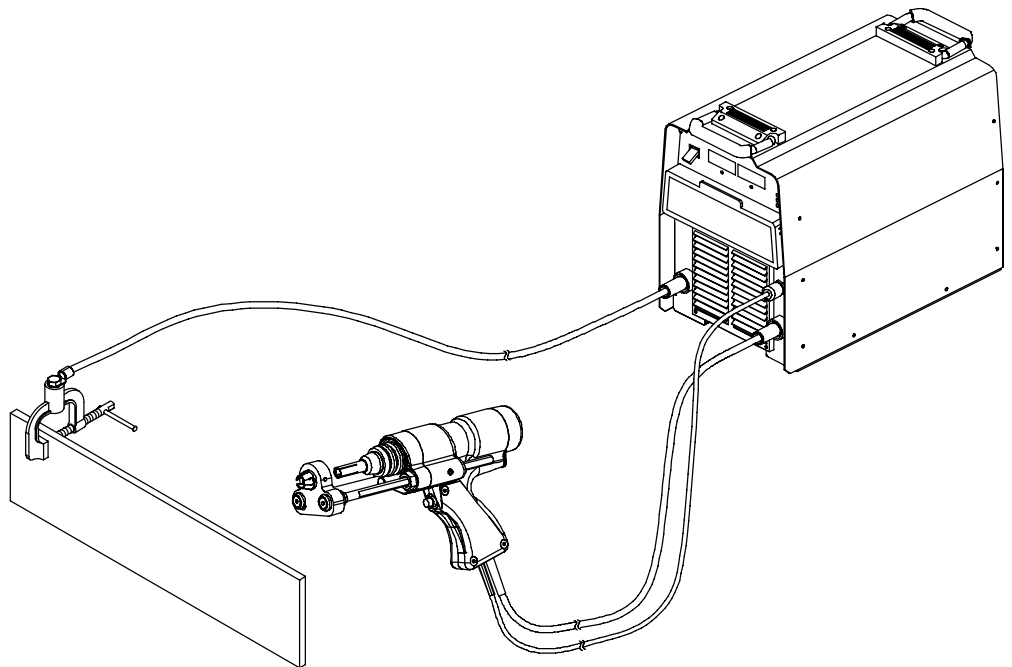

003 338B

July 2005

Arc Stud Welding Fundamentals



Visit our website at
www.MillerWelds.com

TABLE OF CONTENTS

SECTION 1 – SAFETY PRECAUTIONS - READ BEFORE USING	1
1-1. Symbol Usage	1
1-2. Arc Welding Hazards	1
1-3. Additional Symbols For Installation, Operation, And Maintenance	3
1-4. California Proposition 65 Warnings	3
1-5. Principal Safety Standards	4
1-6. EMF Information	4
SECTION 2 – ARC STUD WELDING (SW) GUIDELINES	5
2-1. Process Description	5
2-2. Typical Uses Of The Arc Stud Welding Process	5
2-3. Equipment	5
2-4. Arc Stud Welding System	6
2-5. Power Source	6
2-6. Stud Welding Controls	6
2-7. Volt/Ampere Curve - Constant Current (CC) Power Source	7
2-8. Duty Cycle - Power Source For Constant Current (CC) Welding	7
2-9. Arc Stud Welding Guns	8
2-10. Pistol Grip Stud Gun Components	8
2-11. Selecting Cable Length and Size	9
SECTION 3 – STUD WELDING PROCESS	10
3-1. Stud Welding Sequence	10
3-2. Recommended Procedures And Techniques	10
3-3. The Welding Stud	11
3-4. Arc Shields (Ferrules)	11
3-5. Different Types of Weld Studs And Ceramic Ferrules	11
3-6. Stud Specification Chart	12
3-7. Recommended Settings For Stud Welding Of Steel	12
SECTION 4 – WELD INSPECTION/TROUBLESHOOTING	13
4-1. Inspecting Welded Studs	13
4-2. Performing AWS Bend Test	14
4-3. Performing AWS Torque Test	15

